

Appendix B3

Turning Movement Counts

Project : VBH Malta NY
 Site : Site 4
 Location : 42.948550, -73.790036
 Survey Date : 2021-04-28, Wednesday

Turning Movement Data Plot

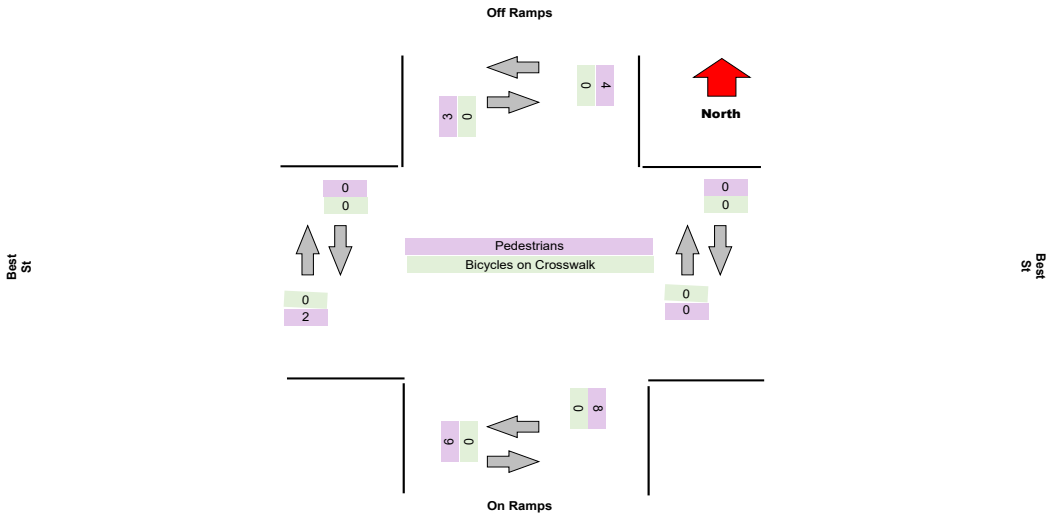
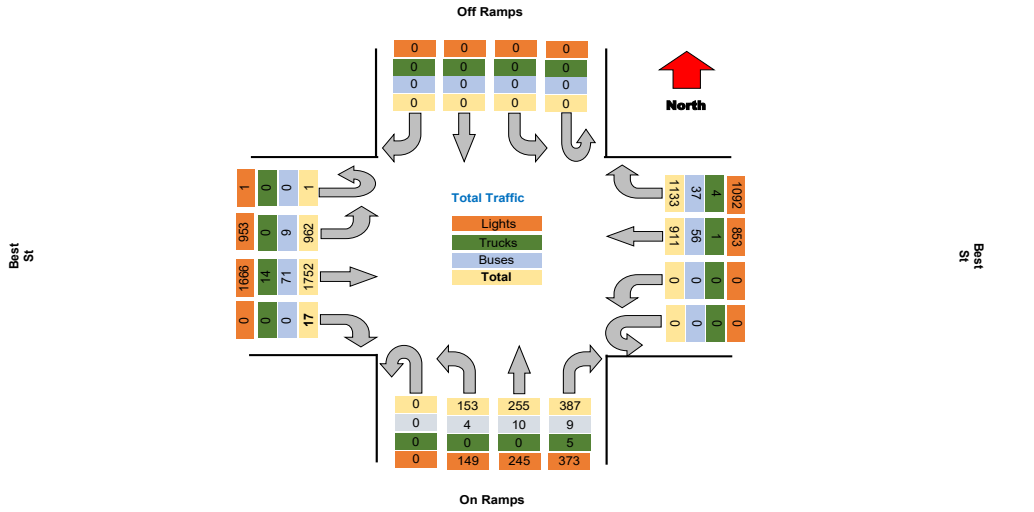

Project : VBH Malta NY
Site : Site 4
Location : 42.948550, -73.790036

TSTData.com

Survey Date : 2021-04-28, Wednesday

Turning Movement Peak Hour Data (AM)

7:30:00 AM

Leg Direction	Off Ramps								Best St								On Ramps								Best St								Total
	Southbound				Westbound				Northbound				Eastbound				Northbound				Eastbound												
Start Time	Right	Thru	Left	U-Turn	App Total	Peds CW	Peds CCW		Right	Thru	Left	U-Turn	App Total	Peds CW	Peds CCW		Right	Thru	Left	U-Turn	App Total	Peds CW	Peds CCW		Right	Thru	Left	U-Turn	App Total	Peds CW	Peds CCW		
7:30:00 AM	0	0	0	0	0	0	0		55	56	0	0	111	0	0		17	17	10	0	44	0	0		0	74	70	0	144	0	0		299
7:45:00 AM	0	0	0	0	0	1	3		82	84	0	0	169	0	0		28	19	15	0	62	0	0		0	115	71	0	186	0	0		417
8:00:00 AM	0	0	0	0	0	0	0		66	72	0	0	138	0	0		34	16	15	0	65	1	1		0	125	78	0	203	0	0		406
8:15:00 AM	0	0	0	0	0	0	0		68	74	0	0	142	0	0		16	12	16	0	44	0	0		0	102	67	0	169	0	0		355
Grand Total	0	0	0	0	0	1	3		271	286	0	0	559	0	0		95	64	56	0	215	1	1		0	416	285	0	702	0	0		1477
% Approach	#DIV/0!	#DIV/0!	#DIV/0!	#DIV/0!	0.0%	0.0%	0.0%		14.2%	85.8%	0.0%	0.0%	0.0%	0.0%	0.0%		45.1%	41.7%	13.2%	0.0%	0.0%	0.0%	0.0%		0.0%	66.2%	33.8%	0.0%	0.0%	0.0%	0.0%		
% Total	0.0%	0.0%	0.0%	0.0%	0.0%	0.0%	0.0%		18.3%	19.4%	0.0%	0.0%	37.9%	0.0%	0.0%		6.4%	4.3%	3.8%	0.0%	14.6%	0.0%	0.0%		0.0%	28.2%	19.4%	0.0%	47.5%	0.0%	0.0%		
PHF	0.000	0.000	0.000	0.000	0.000	0.000	0.000		0.826	0.851	0.000	0.000	0.828	0.000	0.000		0.699	0.842	0.875	0.000	0.827	0.000	0.000		0.000	0.832	0.917	0.000	0.865	0.000	0.000		0.885
Lights	0	0	0	0	0	0	0		266	266	0	0	532	0	0		90	58	53	0	201	0	0		0	403	282	0	685	0	0		1418
% Lights	0.0%	0.0%	0.0%	0.0%	0.0%	0.0%	0.0%		88.2%	93.0%	0.0%	0.0%	95.0%	0.0%	0.0%		84.7%	90.6%	94.6%	0.0%	93.5%	0.0%	0.0%		0.0%	96.9%	98.6%	0.0%	97.6%	0.0%	0.0%		96.0%
Trucks	0	0	0	0	0	0	0		2	1	0	0	3	0	0		1	0	0	0	1	0	0		0	5	0	0	5	0	0		9
% Trucks	0.0%	0.0%	0.0%	0.0%	0.0%	0.0%	0.0%		0.7%	0.3%	0.0%	0.0%	0.5%	0.0%	0.0%		1.1%	0.0%	0.0%	0.0%	0.5%	0.0%	0.0%		0.0%	1.2%	0.0%	0.0%	0.7%	0.0%	0.0%		0.6%
Buses	0	0	0	0	0	0	0		3	18	0	0	21	0	0		4	6	3	0	13	0	0		0	8	4	0	12	0	0		46
% Buses	0.0%	0.0%	0.0%	0.0%	0.0%	0.0%	0.0%		1.1%	6.3%	0.0%	0.0%	0.0%	0.0%	0.0%		4.2%	9.4%	5.4%	0.0%	0.0%	0.0%	0.0%		0.0%	1.9%	1.4%	0.0%	0.0%	0.0%	0.0%		3.1%
Pedestrians	0	0	0	0	1	3	0		0	0	0	0	0	0	0		0	0	0	0	1	1	0		0	0	0	0	0	0	0		0
% Pedestrians	0.0%	0.0%	0.0%	0.0%	100.0%	100.0%	0.0%		0.0%	0.0%	0.0%	0.0%	0.0%	0.0%	0.0%		0.0%	0.0%	0.0%	0.0%	0.0%	100.0%	100.0%		0.0%	0.0%	0.0%	0.0%	0.0%	0.0%	0.0%		0.0%
Bicycles on Crosswalk	0	0	0	0	0	0	0		0	0	0	0	0	0	0		0	0	0	0	0	0	0	0	0	0	0	0	0	0	0		0
% Bicycles on Crosswalk	0.0%	0.0%	0.0%	0.0%	0.0%	0.0%	0.0%		0.0%	0.0%	0.0%	0.0%	0.0%	0.0%	0.0%		0.0%	0.0%	0.0%	0.0%	0.0%	0.0%	0.0%	0.0%	0.0%	0.0%	0.0%	0.0%	0.0%	0.0%	0.0%		0.0%

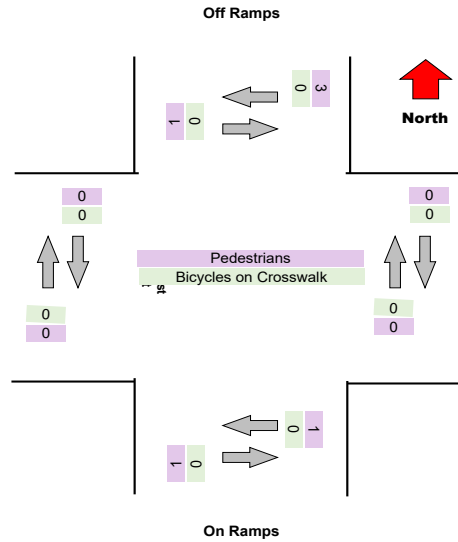
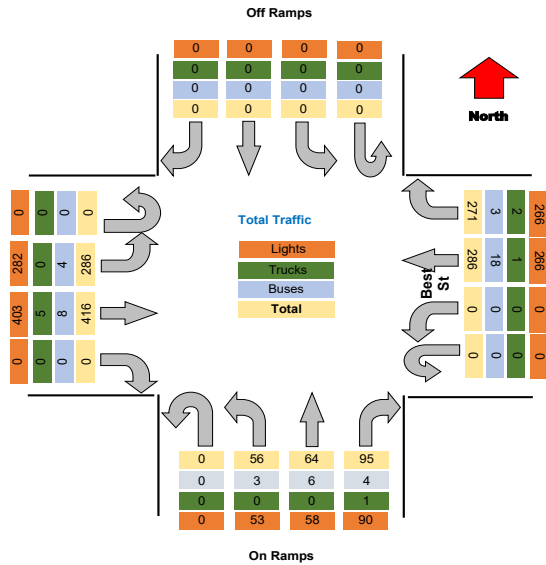

Turning Movement Peak Hour Data (PM)

4:30:00 PM

Leg Direction	Off Ramps										Best St				On Ramps										Best St				Total		
	Southbound					Westbound					Northbound					Eastbound															
	Right	Thru	Left	U-Turn	App Total	Right	Thru	Left	U-Turn	App Total	Right	Thru	Left	U-Turn	App Total	Right	Thru	Left	U-Turn	App Total											
4:30:00 PM	0	0	0	0	0	92	54	0	0	146	37	19	11	0	67	1	0	0	0	1	0	155	77	0	232	1	0	0	0	1	445
4:45:00 PM	0	0	0	0	0	77	57	0	0	134	28	19	12	0	59	1	2	0	0	3	0	143	63	0	206	0	0	0	0	0	399
5:00:00 PM	0	0	0	0	0	76	58	0	0	134	37	19	7	0	63	1	0	0	0	1	0	129	93	0	222	0	0	0	0	0	419
5:15:00 PM	0	0	0	0	0	82	58	0	0	140	29	15	7	0	51	0	1	0	0	1	0	115	69	1	185	0	0	0	0	0	376
Grand Total	0	0	0	0	0	327	227	0	0	554	131	72	37	0	240	3	2	0	0	5	0	542	302	1	845	1	0	0	0	1	1639
% Approach	#DIV/0!	#DIV/0!	#DIV/0!	#DIV/0!	0.0%	14.2%	85.8%	0.0%	0.0%	0.0%	45.1%	41.7%	13.2%	0.0%	0.0%	0.0%	0.0%	0.0%	0.0%	0.0%	0.0%	66.2%	33.8%	0.0%	0.0%	0.0%	0.0%	0.0%	0.0%	0.0%	
% Total	0.0%	0.0%	0.0%	0.0%	0.0%	20.0%	13.8%	0.0%	0.0%	33.8%	8.0%	4.4%	2.3%	0.0%	14.6%	0.0%	0.0%	0.0%	0.0%	0.0%	0.0%	33.1%	18.4%	0.1%	51.6%	0.0%	0.0%	0.0%	0.0%	0.0%	
PHF	0.000	0.000	0.000	0.000	0.000	0.889	0.978	0.000	0.000	0.949	0.885	0.947	0.771	0.000	0.896	0.000	0.000	0.000	0.000	0.000	0.000	0.874	0.812	0.250	0.911	0.000	0.000	0.000	0.000	0.921	
Lights	0	0	0	0	0	325	219	0	0	544	129	70	37	0	236	0	0	0	0	0	0	517	299	1	817	0	0	0	0	0	1597
% Lights	0.0%	0.0%	0.0%	0.0%	0.0%	99.4%	96.5%	0.0%	0.0%	98.2%	98.5%	97.2%	100.0%	0.0%	98.3%	0.0%	0.0%	0.0%	0.0%	0.0%	0.0%	95.4%	99.0%	100.0%	96.7%	0.0%	0.0%	0.0%	0.0%	97.4%	
Trucks	0	0	0	0	0	1	0	0	0	1	1	0	0	0	1	0	0	0	0	0	0	1	0	0	1	0	0	0	0	0	3
% Trucks	0.0%	0.0%	0.0%	0.0%	0.0%	0.3%	0.0%	0.0%	0.0%	0.2%	0.8%	0.0%	0.0%	0.0%	0.4%	0.0%	0.0%	0.0%	0.0%	0.0%	0.0%	0.2%	0.0%	0.0%	0.1%	0.0%	0.0%	0.0%	0.0%	0.2%	
Buses	0	0	0	0	0	1	8	0	0	9	1	2	0	0	3	0	0	0	0	0	0	24	3	0	27	0	0	0	0	0	39
% Buses	0.0%	0.0%	0.0%	0.0%	0.0%	0.3%	3.5%	0.0%	0.0%	0.0%	0.8%	2.8%	0.0%	0.0%	0.0%	0.0%	0.0%	0.0%	0.0%	0.0%	0.0%	4.4%	1.0%	0.0%	0.0%	0.0%	0.0%	0.0%	0.0%	2.4%	
Pedestrians	0	0	0	0	0	0	0	0	0	0	0	0	0	0	0	3	3	0	0	6	0	0	0	0	0	1	0	0	0	1	0.6%
% Pedestrians	0.0%	0.0%	0.0%	0.0%	0.0%	0.0%	0.0%	0.0%	0.0%	0.0%	0.0%	0.0%	0.0%	0.0%	0.0%	100.0%	100.0%	0.0%	0.0%	0.0%	0.0%	0.0%	0.0%	0.0%	0.0%	100.0%	0.0%	0.0%	0.0%	0.6%	
Bicycles on Crosswalk	0	0	0	0	0	0	0	0	0	0	0	0	0	0	0	0	0	0	0	0	0	0	0	0	0	0	0	0	0	0	0
% Bicycles on Crosswalk	0.0%	0.0%	0.0%	0.0%	0.0%	0.0%	0.0%	0.0%	0.0%	0.0%	0.0%	0.0%	0.0%	0.0%	0.0%	0.0%	0.0%	0.0%	0.0%	0.0%	0.0%	0.0%	0.0%	0.0%	0.0%	0.0%	0.0%	0.0%	0.0%	0.8%	

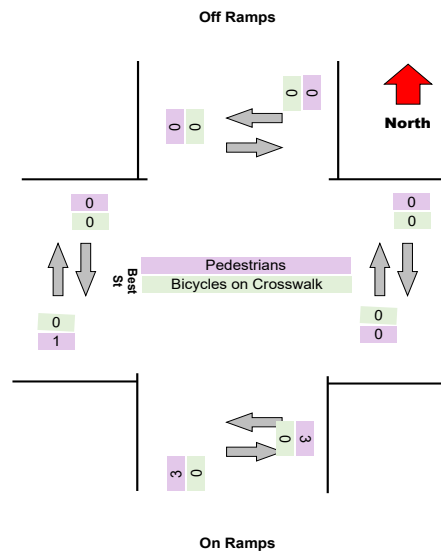
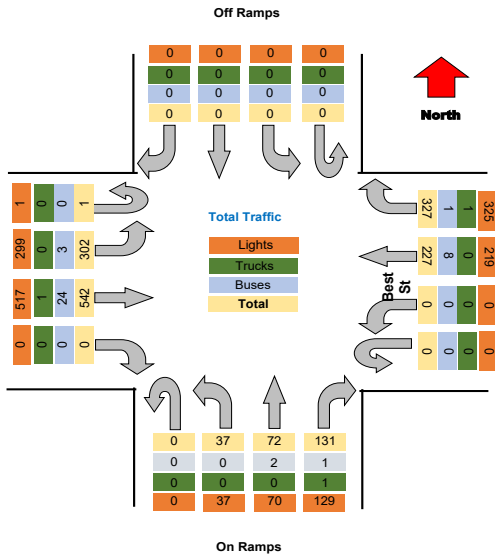

Survey Date : 2021-04-28, Wednesday

Project	Labella
Project Code	Labella
Site Name	1
Legs and Movements	All Processed Legs & Moves
Bin Size	15 minutes
Survey Date	2021-10-27, Wednesday
Location	1
Latitude and Longitude	42.903770, -78.845379

	Start	End	PHF
Forced Peak AM	2021/10/27 07:30:00	2021/10/27 08:30:00	0.93
Forced Peak PM	2021/10/27 16:30:00	2021/10/27 17:30:00	0.93
AM Peak	2021/10/27 07:30:00	2021/10/27 08:30:00	0.93
PM Peak	2021/10/27 16:30:00	2021/10/27 17:30:00	0.93

Turning Movement Data

Leg Direction	Off Ramps							Best St							On Ramps							Best St							Total
	Southbound				Westbound			Northbound				Eastbound			Northbound				Eastbound										
	Right	Thru	Left	U-Turn	App Total	Peds CV	Peds CCV	Right	Thru	Left	U-Turn	App Total	Peds CV	Peds CCV	Right	Thru	Left	U-Turn	App Total	Peds CV	Peds CCV	Right	Thru	Left	U-Turn	App Total	Peds CV	Peds CCV	
6:30:00 AM	0	0	0	0	0	0	0	37	26	0	0	63	0	0	7	12	7	0	26	0	0	0	41	27	0	68	0	0	167
6:45:00 AM	0	0	0	0	0	0	0	43	43	0	0	86	0	0	7	7	3	0	17	0	0	0	39	25	0	64	0	0	167
Hourly Total	0	0	0	0	0	0	0	80	69	0	0	149	0	0	14	19	10	0	43	0	0	0	80	52	0	132	0	0	324
7:00:00 AM	0	0	0	0	0	0	0	31	28	0	0	59	0	0	14	7	4	0	25	0	0	0	53	38	0	91	0	0	175
7:15:00 AM	0	0	0	0	0	1	0	51	37	0	0	88	0	0	15	13	7	0	35	0	0	0	59	28	0	87	0	0	210
7:30:00 AM	0	0	0	0	0	0	0	54	67	0	0	121	0	0	23	16	10	0	49	0	0	0	106	70	0	176	0	0	346
7:45:00 AM	0	0	0	0	0	1	0	64	92	0	0	156	0	0	29	22	10	0	61	0	0	0	117	80	0	197	0	0	414
Hourly Total	0	0	0	0	0	2	0	200	224	0	0	424	0	0	81	58	31	0	170	0	0	0	335	218	0	551	0	0	1145
8:00:00 AM	0	0	0	0	0	2	0	73	63	0	0	138	0	0	30	9	14	0	53	2	2	0	114	74	0	188	0	0	379
8:15:00 AM	0	0	0	0	0	1	0	91	80	0	0	172	0	0	26	13	13	0	52	0	0	0	103	67	0	170	0	0	394
Hourly Total	0	0	0	0	0	3	0	164	143	0	0	310	0	0	56	22	27	0	105	2	2	0	217	141	0	358	0	0	773
4:00:00 PM	0	0	0	0	0	3	0	129	83	0	0	212	0	0	39	32	11	0	82	0	1	0	139	74	0	213	0	0	507
4:15:00 PM	0	0	0	0	0	2	0	100	78	0	0	178	0	0	26	30	11	0	67	0	0	0	148	87	0	235	0	0	480
4:30:00 PM	0	0	0	0	0	0	0	114	66	0	0	179	0	0	30	22	3	0	56	1	0	0	154	83	0	237	0	0	471
4:45:00 PM	0	0	0	0	0	0	0	104	66	0	0	170	0	0	24	19	13	0	56	1	0	0	134	80	0	214	0	0	440
Hourly Total	0	0	0	0	0	5	0	447	292	0	0	739	0	0	119	103	38	0	260	2	1	0	575	324	0	899	0	0	1898
5:00:00 PM	0	0	0	0	0	0	0	93	74	0	1	168	0	0	22	23	9	0	54	0	0	0	124	75	0	199	0	0	421
5:15:00 PM	0	0	0	0	0	1	0	96	71	0	0	167	0	0	27	26	10	0	63	0	0	0	128	59	0	187	0	0	417
5:30:00 PM	0	0	0	0	0	0	0	96	69	0	0	165	0	0	20	13	11	0	44	0	0	0	135	67	0	202	0	0	411
5:45:00 PM	0	0	0	0	0	0	0	72	69	0	0	141	0	0	21	10	5	0	36	0	0	0	119	50	0	169	0	0	346
Hourly Total	0	0	0	0	0	1	0	357	283	0	1	641	0	0	90	72	35	0	197	0	0	0	506	251	0	757	0	0	1595
Grand Total	0	0	0	0	0	3	0	1248	1011	0	1	2263	0	0	360	274	141	0	775	4	3	0	1713	984	0	2697	0	0	5735
% Approach	0.0%	0.0%	0.0%	0.0%	0.0%	0.0%	0.0%	55.1%	44.7%	0.0%	0.0%	0.0%	0.0%	0.0%	46.5%	35.4%	18.2%	0.0%	0.0%	0.0%	0.0%	0.0%	63.5%	36.5%	0.0%	0.0%	0.0%	0.0%	0.0%
% Total	0.0%	0.0%	0.0%	0.0%	0.0%	0.0%	0.0%	21.8%	17.6%	0.0%	0.0%	39.5%	0.0%	0.0%	6.3%	4.8%	2.5%	0.0%	13.5%	0.0%	0.0%	0.0%	29.9%	17.2%	0.0%	47.0%	0.0%	0.0%	0.0%
Lights	0	0	0	0	0	0	0	1205	950	0	1	2156	0	0	346	266	137	0	749	0	0	0	1634	968	0	2602	0	0	5507
% Lights	0.0%	0.0%	0.0%	0.0%	0.0%	0.0%	0.0%	96.9%	94.0%	0.0%	100.0%	95.3%	0.0%	0.0%	96.1%	97.1%	97.2%	0.0%	96.6%	0.0%	0.0%	0.0%	95.4%	98.4%	0.0%	96.5%	0.0%	0.0%	96.9%
Trucks	0	0	0	0	0	0	0	5	3	0	0	8	0	0	3	0	1	0	4	0	0	0	6	2	0	8	0	0	20
% Trucks	0.0%	0.0%	0.0%	0.0%	0.0%	0.0%	0.0%	0.4%	0.3%	0.0%	0.0%	0.4%	0.0%	0.0%	0.8%	0.0%	0.7%	0.0%	0.5%	0.0%	0.0%	0.0%	0.4%	0.2%	0.0%	0.3%	0.0%	0.0%	0.3%
Buses	0	0	0	0	0	0	0	38	59	0	0	96	0	0	10	9	3	0	21	0	0	0	71	14	0	85	0	0	202
% Buses	0.0%	0.0%	0.0%	0.0%	0.0%	0.0%	0.0%	0.0%	5.7%	0.0%	0.0%	0.0%	0.0%	0.0%	2.8%	2.9%	2.1%	0.0%	0.0%	0.0%	0.0%	0.0%	0.0%	1.4%	0.0%	0.0%	0.0%	0.0%	3.5%
Pedestrians	0	0	0	0	0	3	0	0	0	0	0	0	0	0	0	0	0	0	0	4	3	0	0	0	0	0	0	0	0
% Pedestrians	0.0%	0.0%	0.0%	0.0%	0.0%	100.0%	100.0%	0.0%	0.0%	0.0%	0.0%	0.0%	0.0%	0.0%	0.0%	0.0%	0.0%	0.0%	0.0%	100.0%	100.0%	0.0%	0.0%	0.0%	0.0%	0.0%	0.0%	0.0%	0.0%
Bicycles on Crosswalk	0	0	0	0	0	0	0	0	0	0	0	0	0	0	0	0	0	0	0	0	0	0	0	0	0	0	0	0	0
% Bicycles on Crosswalk	0.0%	0.0%	0.0%	0.0%	0.0%	0.0%	0.0%	0.0%	0.0%	0.0%	0.0%	0.0%	0.0%	0.0%	0.0%	0.0%	0.0%	0.0%	0.0%	0.0%	0.0%	0.0%	0.0%	0.0%	0.0%	0.0%	0.0%	0.0%	0.0%

Turning Movement Data Plot

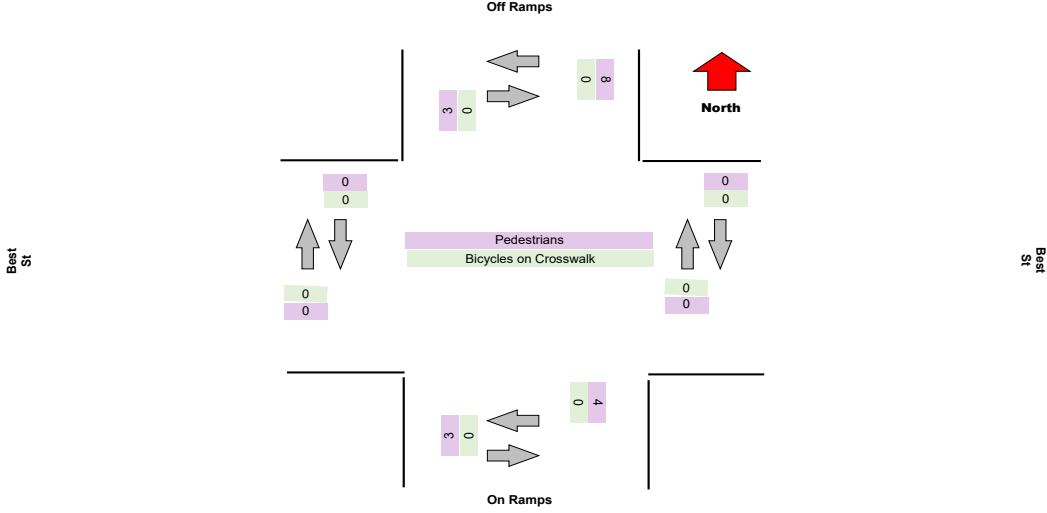
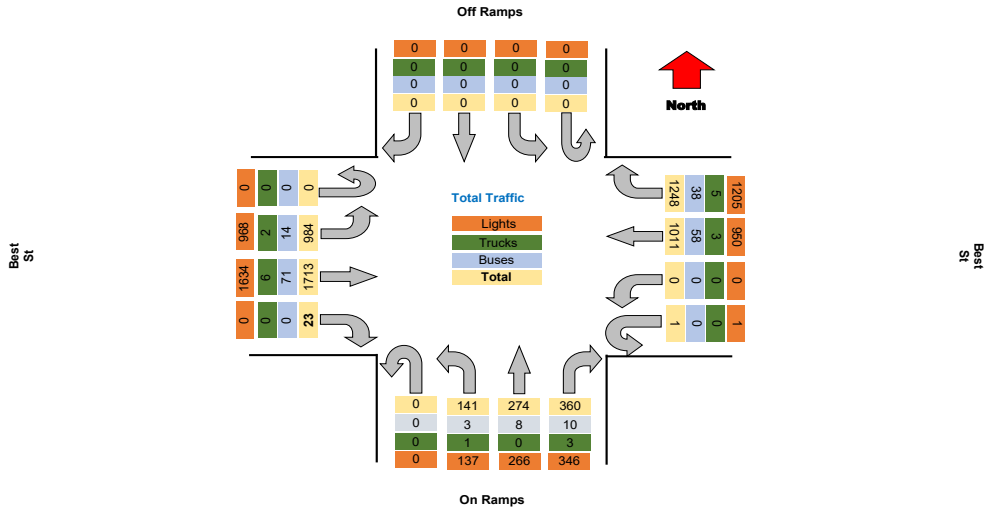

Project : VBH Malta NY
Site : Site 4
Location : 42.948550, -73.790036

TSTData.com

Survey Date : 2021-04-28, Wednesday

Turning Movement Peak Hour Data (AM)

7:30:00 AM

Leg Direction	Off Ramps								Best St				On Ramps				Best St				Total								
	Southbound				Westbound				Northbound				Eastbound																
Start Time	Right	Thru	Left	U-Turn	App Total	Peds CW	Peds CCW	Right	Thru	Left	U-Turn	App Total	Peds CW	Peds CCW	Right	Thru	Left	U-Turn	App Total	Peds CW	Peds CCW								
7:30:00 AM	0	0	0	0	0	0	0	54	67	0	0	121	0	0	23	16	10	0	49	0	0	0	106	70	0	176	0	0	346
7:45:00 AM	0	0	0	0	0	1	0	64	92	0	0	156	0	0	29	22	10	0	61	0	0	0	117	80	0	197	0	0	414
8:00:00 AM	0	0	0	0	0	2	0	73	53	0	0	126	0	0	30	9	14	0	53	2	2	0	114	74	0	188	0	0	379
8:15:00 AM	0	0	0	0	0	1	0	51	60	0	0	112	0	0	25	13	13	0	52	0	0	0	103	67	0	170	0	0	334
Grand Total	0	0	0	0	0	4	0	282	302	0	0	557	0	0	108	60	47	0	215	2	2	0	440	291	0	731	0	0	1533
% Approach	#DIV/0!	#DIV/0!	#DIV/0!	#DIV/0!	0.0%	0.0%	0.0%	14.2%	85.8%	0.0%	0.0%	0.0%	0.0%	0.0%	45.1%	41.7%	13.2%	0.0%	0.0%	0.0%	0.0%	0.0%	66.2%	33.8%	0.0%	0.0%	0.0%	0.0%	95.8%
% Total	0.0%	0.0%	0.0%	0.0%	0.0%	0.0%	0.0%	18.4%	19.7%	0.0%	0.0%	38.3%	0.0%	0.0%	7.0%	3.9%	3.1%	0.0%	14.0%	0.0%	0.0%	0.0%	28.7%	19.0%	0.0%	47.7%	0.0%	0.0%	95.8%
PHF	0.000	0.000	0.000	0.000	0.000	0.000	0.000	0.775	0.821	0.000	0.000	0.853	0.000	0.000	0.900	0.682	0.839	0.000	0.881	0.000	0.000	0.000	0.840	0.909	0.000	0.928	0.000	0.000	0.926
Lights	0	0	0	0	0	0	0	276	280	0	0	556	0	0	101	56	44	0	201	0	0	0	428	284	0	712	0	0	1469
% Lights	0.0%	0.0%	0.0%	0.0%	0.0%	0.0%	0.0%	87.9%	92.7%	0.0%	0.0%	84.7%	0.0%	0.0%	83.5%	83.3%	93.6%	0.0%	93.5%	0.0%	0.0%	0.0%	97.3%	97.6%	0.0%	97.4%	0.0%	0.0%	95.8%
Trucks	0	0	0	0	0	0	0	3	2	0	0	5	0	0	2	0	1	0	3	0	0	0	2	1	0	3	0	0	11
% Trucks	0.0%	0.0%	0.0%	0.0%	0.0%	0.0%	0.0%	1.1%	0.7%	0.0%	0.0%	0.9%	0.0%	0.0%	1.9%	0.0%	2.1%	0.0%	1.4%	0.0%	0.0%	0.0%	0.5%	0.3%	0.0%	0.4%	0.0%	0.0%	0.7%
Buses	0	0	0	0	0	0	0	3	20	0	0	23	0	0	5	4	2	0	11	0	0	0	10	6	0	16	0	0	50
% Buses	0.0%	0.0%	0.0%	0.0%	0.0%	0.0%	0.0%	1.1%	6.6%	0.0%	0.0%	0.0%	0.0%	0.0%	4.6%	6.7%	4.3%	0.0%	0.0%	0.0%	0.0%	0.0%	2.3%	2.1%	0.0%	0.0%	0.0%	0.0%	3.3%
Pedestrians	0	0	0	0	0	1	3	0	0	0	0	0	0	0	0	0	0	0	2	2	0	0	0	0	0	0	0	0	
% Pedestrians	0.0%	0.0%	0.0%	0.0%	0.0%	100.0%	100.0%	0.0%	0.0%	0.0%	0.0%	0.0%	0.0%	0.0%	0.0%	0.0%	0.0%	0.0%	100.0%	100.0%	0.0%	0.0%	0.0%	0.0%	0.0%	0.0%	0.0%	0.0%	
Bicycles on Crosswalk	0	0	0	0	0	0	0	0	0	0	0	0	0	0	0	0	0	0	0	0	0	0	0	0	0	0	0	0	0
% Bicycles on Crosswalk	0.0%	0.0%	0.0%	0.0%	0.0%	0.0%	0.0%	0.0%	0.0%	0.0%	0.0%	0.0%	0.0%	0.0%	0.0%	0.0%	0.0%	0.0%	0.0%	0.0%	0.0%	0.0%	0.0%	0.0%	0.0%	0.0%	0.0%	0.0%	0.0%

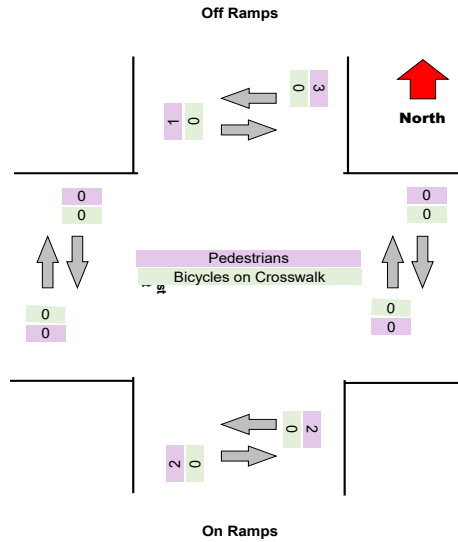
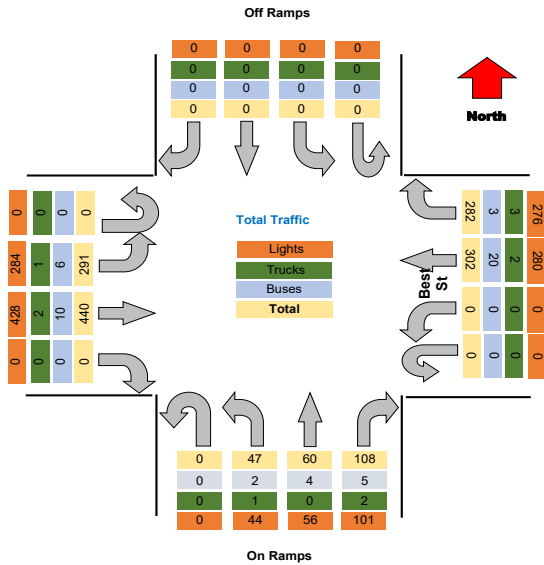

Turning Movement Peak Hour Data (PM)

4:30:00 PM

Leg Direction	Off Ramps										Best St										On Ramps										Best St										Total
	Southbound					Westbound					Northbound					Eastbound																									
	Right	Thru	Left	U-Turn	App Total	Right	Thru	Left	U-Turn	App Total	Right	Thru	Left	U-Turn	App Total	Right	Thru	Left	U-Turn	App Total																					
4:30:00 PM	0	0	0	0	0	114	65	0	0	179	30	22	3	0	55	1	0	0	0	1	0	154	83	0	237	0	0	0	0	0	471										
4:45:00 PM	0	0	0	0	0	104	66	0	0	170	24	19	13	0	56	1	0	0	0	1	0	134	80	0	214	0	0	0	0	0	440										
5:00:00 PM	0	0	0	0	0	93	74	0	1	168	22	23	9	0	54	0	0	0	0	0	0	124	75	0	199	0	0	0	0	0	421										
5:15:00 PM	0	0	0	0	0	96	71	0	0	167	27	26	10	0	63	0	0	0	0	0	0	128	59	0	187	0	0	0	0	0	417										
Grand Total	0	0	0	0	0	407	276	0	1	684	103	90	35	0	228	2	0	0	0	2	0	540	297	0	837	0	0	0	0	0	1749										
% Approach	#DIV/0!	#DIV/0!	#DIV/0!	#DIV/0!	0.0%	14.2%	85.8%	0.0%	0.0%	0.0%	45.1%	41.7%	13.2%	0.0%	0.0%	0.0%	66.2%	33.8%	0.0%	0.0%	0.0%	66.2%	33.8%	0.0%	0.0%	0.0%	0.0%	0.0%	0.0%	0.0%											
% Total	0.0%	0.0%	0.0%	0.0%	0.0%	23.3%	15.8%	0.0%	0.1%	38.1%	5.9%	5.1%	2.0%	0.0%	13.0%	0.0%	30.9%	17.0%	0.0%	47.9%	0.0%	30.9%	17.0%	0.0%	47.9%	0.0%	0.0%	0.0%	0.0%	0.0%											
PHF	0.000	0.000	0.000	0.000	0.000	0.893	0.932	0.000	0.250	0.955	0.858	0.865	0.673	0.000	0.905	0.000	0.877	0.895	0.000	0.883	0.000	0.877	0.895	0.000	0.883	0.000	0.000	0.000	0.000	0.000	0.928										
Lights	0	0	0	0	0	404	271	0	1	676	101	88	35	0	224	0	0	0	0	0	0	513	293	0	806	0	0	0	0	0	1706										
% Lights	0.0%	0.0%	0.0%	0.0%	0.0%	99.3%	98.2%	0.0%	100.0%	98.8%	98.1%	97.8%	100.0%	0.0%	98.2%	0.0%	95.0%	98.7%	0.0%	96.3%	0.0%	95.0%	98.7%	0.0%	96.3%	0.0%	0.0%	0.0%	0.0%	0.0%	97.5%										
Trucks	0	0	0	0	0	1	0	0	0	1	0	0	0	0	0	0	0	1	0	1	0	0	1	0	1	0	0	0	0	0	2										
% Trucks	0.0%	0.0%	0.0%	0.0%	0.0%	0.2%	0.0%	0.0%	0.0%	0.1%	0.0%	0.0%	0.0%	0.0%	0.0%	0.0%	0.0%	0.3%	0.0%	0.1%	0.0%	0.0%	0.3%	0.0%	0.1%	0.0%	0.0%	0.0%	0.0%	0.0%	0.1%										
Buses	0	0	0	0	0	2	5	0	0	7	1	2	0	0	3	0	0	0	0	0	0	26	3	0	29	0	0	0	0	0	39										
% Buses	0.0%	0.0%	0.0%	0.0%	0.0%	0.5%	1.8%	0.0%	0.0%	0.0%	1.0%	2.2%	0.0%	0.0%	0.0%	0.0%	4.8%	1.0%	0.0%	0.0%	0.0%	4.8%	1.0%	0.0%	0.0%	0.0%	0.0%	0.0%	0.0%	0.0%	2.2%										
Pedestrians	0	0	0	0	0	0	0	0	0	0	0	0	0	0	0	2	0	0	0	0	0	0	0	0	0	0	0	0	0	0	0										
% Pedestrians	0.0%	0.0%	0.0%	0.0%	0.0%	0.0%	0.0%	0.0%	0.0%	0.0%	0.0%	0.0%	0.0%	0.0%	0.0%	0.9%	100.0%	0.0%	0.0%	0.0%	0.0%	0.0%	0.0%	0.0%	0.0%	0.0%	0.0%	0.0%	0.0%	0.0%	0.0%										
Bicycles on Crosswalk	0	0	0	0	0	0	0	0	0	0	0	0	0	0	0	0	0	0	0	0	0	0	0	0	0	0	0	0	0	0	0										
% Bicycles on Crosswalk	0.0%	0.0%	0.0%	0.0%	0.0%	0.0%	0.0%	0.0%	0.0%	0.0%	0.0%	0.0%	0.0%	0.0%	0.0%	0.0%	0.0%	0.0%	0.0%	0.0%	0.0%	0.0%	0.0%	0.0%	0.0%	0.0%	0.0%	0.0%	0.0%	0.0%	0.0%										

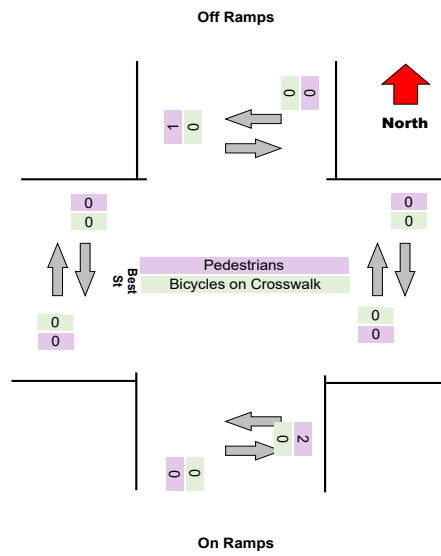
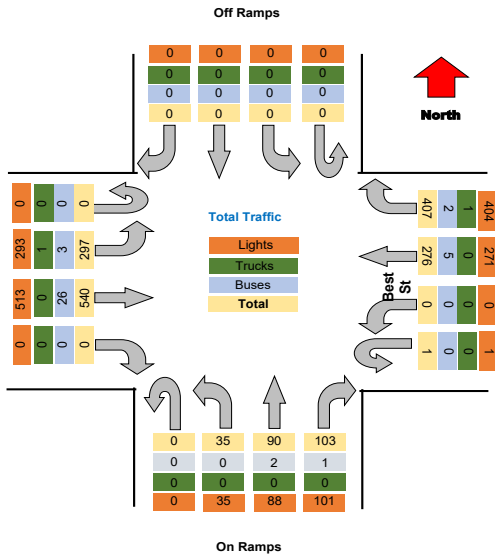

Project : VBH Malta NY
 Site : Site 4
 Location : 42.948550, -73.790036
 Survey Date : 2021-04-28, Wednesday

Turning Movement Data Plot

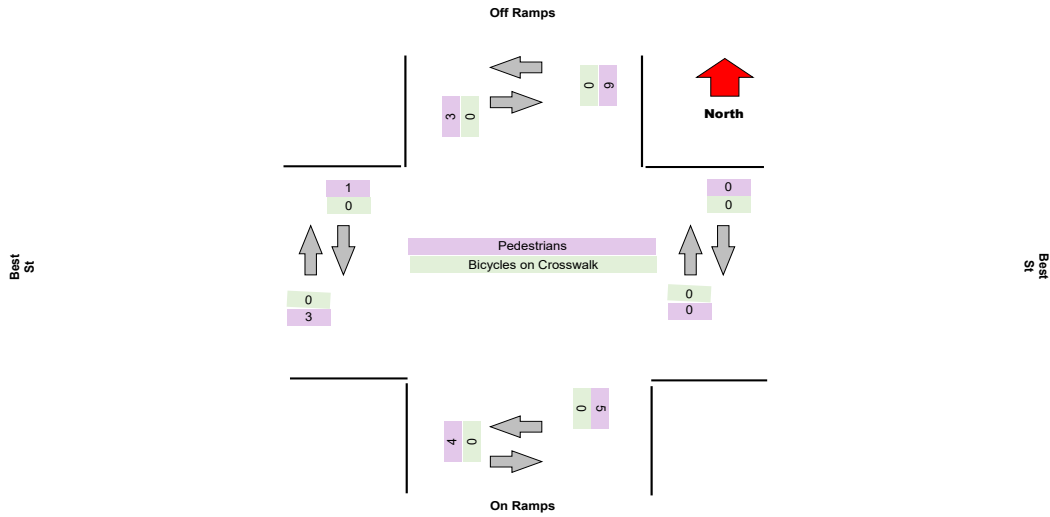
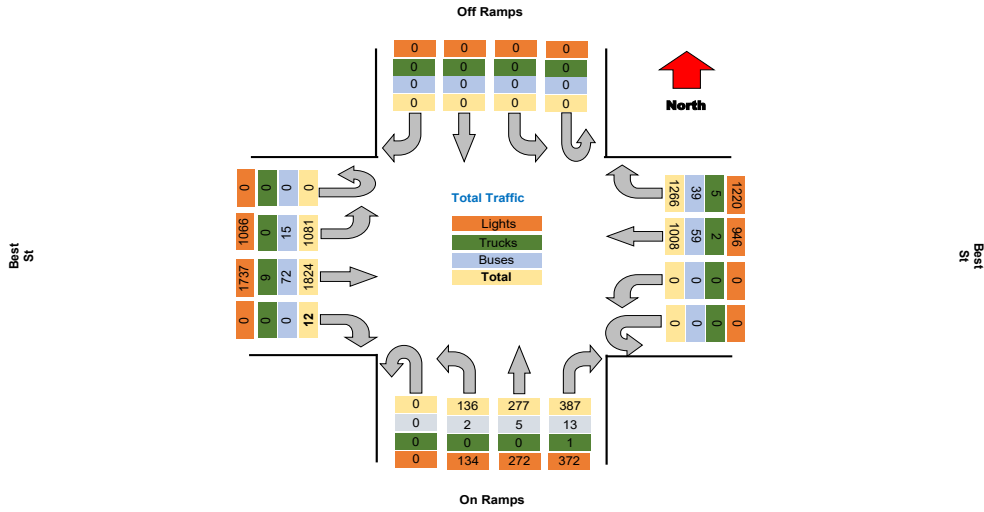

Turning Movement Peak Hour Data (AM)

7:30:00 AM

Leg Direction	Off Ramps							Best St							On Ramps							Best St							Total
	Southbound				Westbound			Northbound				Eastbound			Northbound				Eastbound										
Start Time	Right	Thru	Left	U-Turn	App Total	Peds CW	Peds CCW	Right	Thru	Left	U-Turn	App Total	Peds CW	Peds CCW	Right	Thru	Left	U-Turn	App Total	Peds CW	Peds CCW	Right	Thru	Left	U-Turn	App Total	Peds CW	Peds CCW	
7:30:00 AM	0	0	0	0	0	1	1	47	69	0	0	117	0	0	12	12	8	0	32	0	0	0	89	60	0	149	1	0	298
7:45:00 AM	0	0	0	0	0	0	1	72	78	0	0	151	0	0	40	12	7	0	59	0	0	0	124	78	0	202	1	0	412
8:00:00 AM	0	0	0	0	0	0	0	82	69	0	0	151	0	0	39	12	11	0	62	0	1	0	126	78	0	204	0	0	417
8:15:00 AM	0	0	0	0	0	0	1	66	70	0	0	137	0	0	20	15	8	0	43	0	0	0	106	72	0	178	0	0	358
Grand Total	0	0	0	0	0	1	1	267	286	0	0	556	0	0	111	51	34	0	196	0	1	0	445	288	0	733	2	0	1485
% Approach	#DIV/0!	#DIV/0!	#DIV/0!	#DIV/0!	0.0%	0.0%	0.0%	14.2%	85.8%	0.0%	0.0%	0.0%	0.0%	0.0%	45.1%	41.7%	13.2%	0.0%	0.0%	0.0%	0.0%	0.0%	66.2%	33.8%	0.0%	0.0%	0.0%	0.0%	
% Total	0.0%	0.0%	0.0%	0.0%	0.0%	0.0%	0.0%	18.0%	19.3%	0.0%	0.0%	37.4%	0.0%	0.0%	7.5%	3.4%	2.3%	0.0%	13.2%	0.0%	0.0%	0.0%	30.0%	19.4%	0.0%	49.4%	0.0%	0.0%	
PHF	0.000	0.000	0.000	0.000	0.000	0.000	0.000	0.814	0.917	0.000	0.000	0.921	0.000	0.000	0.694	0.850	0.773	0.000	0.790	0.000	0.000	0.000	0.883	0.923	0.000	0.898	0.000	0.000	
Lights	0	0	0	0	0	0	0	261	267	0	0	528	0	0	106	48	32	0	186	0	0	0	437	281	0	718	0	0	
% Lights	0.0%	0.0%	0.0%	0.0%	0.0%	0.0%	0.0%	87.8%	93.4%	0.0%	0.0%	95.0%	0.0%	0.0%	95.5%	94.1%	94.1%	0.0%	94.9%	0.0%	0.0%	0.0%	98.2%	97.6%	0.0%	98.0%	0.0%	0.0%	
Trucks	0	0	0	0	0	0	0	1	0	0	0	1	0	0	1	0	0	0	1	0	0	0	3	0	0	3	0	0	
% Trucks	0.0%	0.0%	0.0%	0.0%	0.0%	0.0%	0.0%	0.4%	0.0%	0.0%	0.0%	0.2%	0.0%	0.0%	0.9%	0.0%	0.0%	0.0%	0.5%	0.0%	0.0%	0.0%	0.7%	0.0%	0.0%	0.4%	0.0%	0.0%	
Buses	0	0	0	0	0	0	0	5	19	0	0	24	0	0	4	3	2	0	9	0	0	0	5	7	0	12	0	0	
% Buses	0.0%	0.0%	0.0%	0.0%	0.0%	0.0%	0.0%	1.9%	6.6%	0.0%	0.0%	0.0%	0.0%	0.0%	3.6%	5.9%	5.9%	0.0%	0.0%	0.0%	0.0%	0.0%	1.1%	2.4%	0.0%	0.0%	0.0%	0.0%	
Pedestrians	0	0	0	0	0	1	1	0	0	0	0	0	0	0	0	0	0	0	0	0	1	0	0	0	0	0	2	0	
% Pedestrians	0.0%	0.0%	0.0%	0.0%	0.0%	100.0%	100.0%	0.0%	0.0%	0.0%	0.0%	0.0%	0.0%	0.0%	0.0%	0.0%	0.0%	0.0%	0.0%	100.0%	0.0%	0.0%	0.0%	0.0%	0.0%	100.0%	0.0%		
Bicycles on Crosswalk	0	0	0	0	0	0	0	0	0	0	0	0	0	0	0	0	0	0	0	0	0	0	0	0	0	0	0	0	
% Bicycles on Crosswalk	0.0%	0.0%	0.0%	0.0%	0.0%	0.0%	0.0%	0.0%	0.0%	0.0%	0.0%	0.0%	0.0%	0.0%	0.0%	0.0%	0.0%	0.0%	0.0%	0.0%	0.0%	0.0%	0.0%	0.0%	0.0%	0.0%	0.0%		

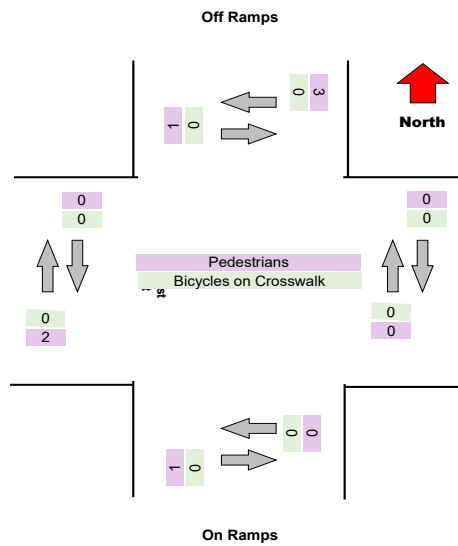
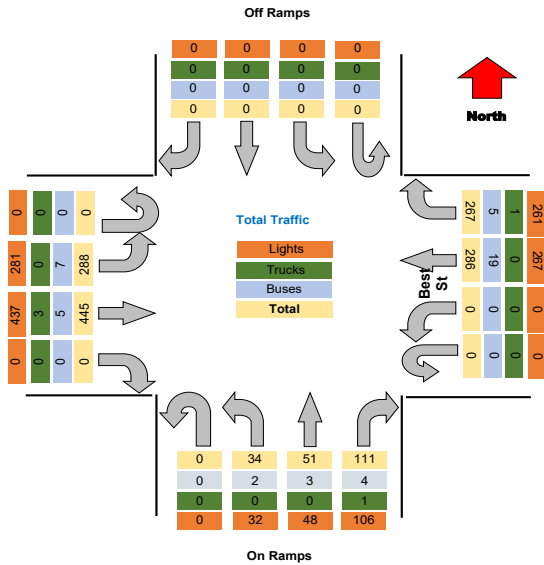

Turning Movement Peak Hour Data (PM)

4:30:00 PM

Leg Direction	Off Ramps										Best St						On Ramps						Best St						Total					
	Southbound					Westbound					Northbound			Eastbound			Northbound			Eastbound														
	Right	Thru	Left	U-Turn	App Total	Right	Thru	Left	U-Turn	App Total	Right	Thru	Left	Right	Thru	Left	Right	Thru	Left	Right	Thru	Left	Right	Thru	Left	Right	Thru	Left		U-Turn	App Total	Peds CW	Peds CCW	
4:30:00 PM	0	0	0	0	0	129	63	0	0	192	36	38	8	0	82	3	0	0	0	131	83	0	214	0	0	0	0	0	0	0	0	0	0	488
4:45:00 PM	0	0	0	0	0	94	80	0	0	174	27	19	9	0	55	1	1	0	155	75	0	230	0	0	0	0	0	0	0	0	0	0	459	
5:00:00 PM	0	0	0	0	0	89	57	0	0	146	27	14	9	0	50	0	0	0	148	79	0	227	0	0	0	0	0	0	0	0	0	0	459	
5:15:00 PM	0	0	0	0	0	83	77	0	0	160	25	30	7	0	62	0	0	0	126	111	0	237	0	0	0	0	0	0	0	0	0	0	459	
Grand Total	0	0	0	0	0	395	277	0	0	672	115	101	33	0	249	4	1	0	522	344	0	866	0	0	0	0	0	0	0	0	0	0	1627	
% Approach	#DIV/0!	#DIV/0!	#DIV/0!	#DIV/0!	0.0%	14.2%	85.8%	0.0%	0.0%	0.0%	45.1%	41.7%	13.2%	0.0%	0.0%	0.0%	0.0%	0.0%	66.2%	33.8%	0.0%	0.0%	0.0%	0.0%	0.0%	0.0%	0.0%	0.0%	0.0%	0.0%	0.0%	0.0%		
% Total	0.0%	0.0%	0.0%	0.0%	0.0%	21.6%	15.2%	0.0%	0.0%	36.8%	6.3%	5.5%	1.8%	0.0%	13.6%	0.0%	0.0%	0.0%	30.5%	19.0%	0.0%	49.6%	0.0%	0.0%	0.0%	0.0%	0.0%	0.0%	0.0%	0.0%	0.0%	0.0%		
PHF	0.000	0.000	0.000	0.000	0.000	0.766	0.866	0.000	0.000	0.875	0.799	0.664	0.917	0.000	0.759	0.000	0.000	0.000	0.900	0.784	0.000	0.956	0.000	0.000	0.000	0.000	0.000	0.000	0.000	0.000	0.000	0.936		
Lights	0	0	0	0	0	393	271	0	0	664	113	101	33	0	247	0	0	0	522	344	0	866	0	0	0	0	0	0	0	0	0	0	1777	
% Lights	0.0%	0.0%	0.0%	0.0%	0.0%	99.5%	97.8%	0.0%	0.0%	98.8%	98.3%	100.0%	100.0%	0.0%	99.2%	0.0%	0.0%	0.0%	93.5%	98.9%	0.0%	95.6%	0.0%	0.0%	0.0%	0.0%	0.0%	0.0%	0.0%	0.0%	0.0%	97.3%		
Trucks	0	0	0	0	0	1	1	0	0	2	0	0	0	0	0	0	0	0	3	0	0	3	0	0	0	0	0	0	0	0	0	0	5	
% Trucks	0.0%	0.0%	0.0%	0.0%	0.0%	0.3%	0.4%	0.0%	0.0%	0.3%	0.0%	0.0%	0.0%	0.0%	0.0%	0.0%	0.0%	0.0%	0.5%	0.0%	0.0%	0.3%	0.0%	0.0%	0.0%	0.0%	0.0%	0.0%	0.0%	0.0%	0.0%	0.3%		
Buses	0	0	0	0	0	0	4	0	0	4	2	0	0	0	2	0	0	0	30	4	0	34	0	0	0	0	0	0	0	0	0	0	40	
% Buses	0.0%	0.0%	0.0%	0.0%	0.0%	0.0%	1.4%	0.0%	0.0%	0.6%	1.7%	0.0%	0.0%	0.0%	0.8%	0.0%	0.0%	0.0%	5.4%	1.1%	0.0%	0.0%	0.0%	0.0%	0.0%	0.0%	0.0%	0.0%	0.0%	0.0%	0.0%	2.2%		
Pedestrians	0	0	0	0	0	1	2	0	0	3	0	0	0	0	4	1	0	0	0	0	0	0	0	0	0	0	0	0	0	0	0	8		
% Pedestrians	0.0%	0.0%	0.0%	0.0%	0.0%	100.0%	100.0%	0.0%	0.0%	0.0%	0.0%	0.0%	0.0%	0.0%	0.0%	100.0%	100.0%	0.0%	0.0%	0.0%	0.0%	0.0%	0.0%	0.0%	0.0%	0.0%	0.0%	0.0%	0.0%	0.0%	0.0%	0.0%		
Bicycles on Crosswalk	0	0	0	0	0	0	0	0	0	0	0	0	0	0	0	0	0	0	0	0	0	0	0	0	0	0	0	0	0	0	0	0		
% Bicycles on Crosswalk	0.0%	0.0%	0.0%	0.0%	0.0%	0.0%	0.0%	0.0%	0.0%	0.0%	0.0%	0.0%	0.0%	0.0%	0.0%	0.0%	0.0%	0.0%	0.0%	0.0%	0.0%	0.0%	0.0%	0.0%	0.0%	0.0%	0.0%	0.0%	0.0%	0.0%	0.0%	0.0%		

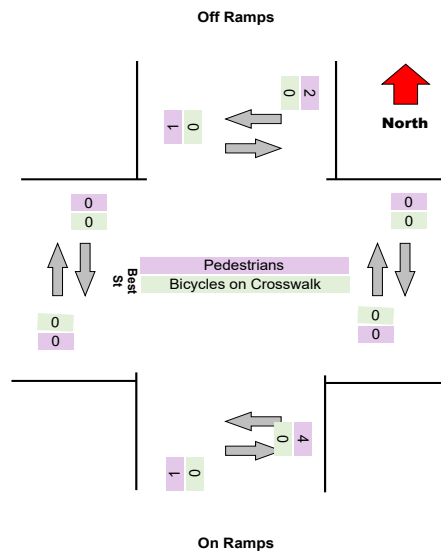
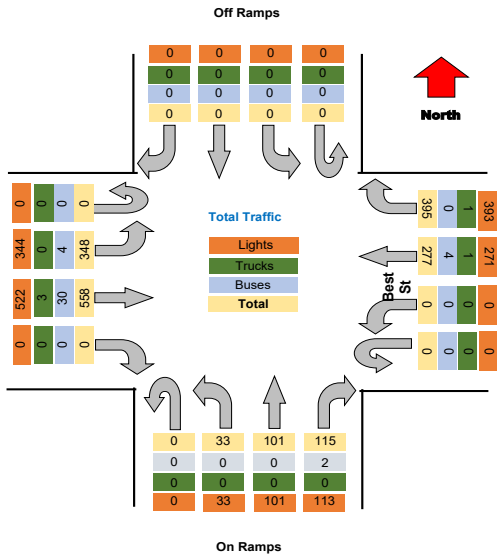

Turning Movement Data Plot

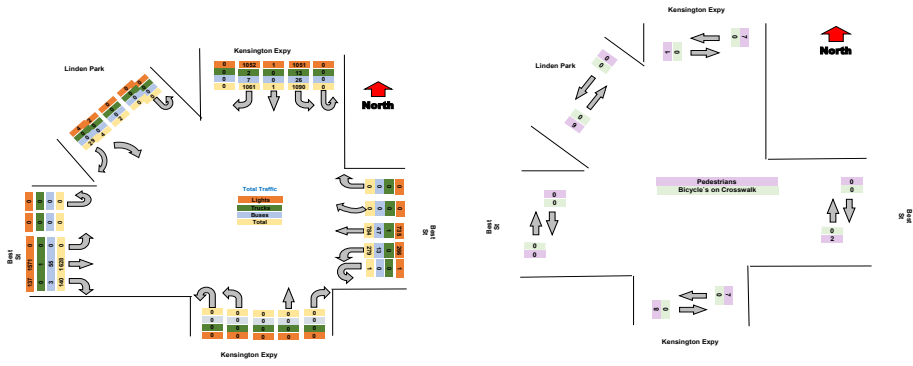

Turning Movement Peak Hour Data (AM)

7:30:00 AM

Link	Kensington Expy										Kensington Expy										Kensington Expy										Kensington Expy									
	Flow	Obs	Est	Obs	Est	Obs	Est	Obs	Est	Obs	Est	Flow	Obs	Est	Obs	Est	Flow	Obs	Est	Obs	Est	Flow	Obs	Est	Obs	Est														
Approach	1	0	0	0	0	0	0	0	0	0	1	0	0	0	0	0	1	0	0	0	0	0	0	0	0	0														
Departure	1	0	0	0	0	0	0	0	0	0	1	0	0	0	0	0	1	0	0	0	0	0	0	0	0	0														
Left	0	0	0	0	0	0	0	0	0	0	0	0	0	0	0	0	0	0	0	0	0	0	0	0	0	0														
Thru	0	0	0	0	0	0	0	0	0	0	0	0	0	0	0	0	0	0	0	0	0	0	0	0	0	0														
Right	0	0	0	0	0	0	0	0	0	0	0	0	0	0	0	0	0	0	0	0	0	0	0	0	0	0														
Left	0	0	0	0	0	0	0	0	0	0	0	0	0	0	0	0	0	0	0	0	0	0	0	0	0	0														
Thru	0	0	0	0	0	0	0	0	0	0	0	0	0	0	0	0	0	0	0	0	0	0	0	0	0	0														
Right	0	0	0	0	0	0	0	0	0	0	0	0	0	0	0	0	0	0	0	0	0	0	0	0	0	0														
Left	0	0	0	0	0	0	0	0	0	0	0	0	0	0	0	0	0	0	0	0	0	0	0	0	0	0														
Thru	0	0	0	0	0	0	0	0	0	0	0	0	0	0	0	0	0	0	0	0	0	0	0	0	0	0														
Right	0	0	0	0	0	0	0	0	0	0	0	0	0	0	0	0	0	0	0	0	0	0	0	0	0	0														
Left	0	0	0	0	0	0	0	0	0	0	0	0	0	0	0	0	0	0	0	0	0	0	0	0	0	0														
Thru	0	0	0	0	0	0	0	0	0	0	0	0	0	0	0	0	0	0	0	0	0	0	0	0	0	0														
Right	0	0	0	0	0	0	0	0	0	0	0	0	0	0	0	0	0	0	0	0	0	0	0	0	0	0														
Left	0	0	0	0	0	0	0	0	0	0	0	0	0	0	0	0	0	0	0	0	0	0	0	0	0	0														
Thru	0	0	0	0	0	0	0	0	0	0	0	0	0	0	0	0	0	0	0	0	0	0	0	0	0	0														
Right	0	0	0	0	0	0	0	0	0	0	0	0	0	0	0	0	0	0	0	0	0	0	0	0	0	0														
Left	0	0	0	0	0	0	0	0	0	0	0	0	0	0	0	0	0	0	0	0	0	0	0	0	0	0														
Thru	0	0	0	0	0	0	0	0	0	0	0	0	0	0	0	0	0	0	0	0	0	0	0	0	0	0														
Right	0	0	0	0	0	0	0	0	0	0	0	0	0	0	0	0	0	0	0	0	0	0	0	0	0	0														
Left	0	0	0	0	0	0	0	0	0	0	0	0	0	0	0	0	0	0	0	0	0	0	0	0	0	0														
Thru	0	0	0	0	0	0	0	0	0	0	0	0	0	0	0	0	0	0	0	0	0	0	0	0	0	0														
Right	0	0	0	0	0	0	0	0	0	0	0	0	0	0	0	0	0	0	0	0	0	0	0	0	0	0														
Left	0	0	0	0	0	0	0	0	0	0	0	0	0	0	0	0	0	0	0	0	0	0	0	0	0	0														
Thru	0	0	0	0	0	0	0	0	0	0	0	0	0	0	0	0	0	0	0	0	0	0	0	0	0	0														
Right	0	0	0	0	0	0	0	0	0	0	0	0	0	0	0	0	0	0	0	0	0	0	0	0	0	0														
Left	0	0	0	0	0	0	0	0	0	0	0	0	0	0	0	0	0	0	0	0	0	0	0	0	0	0														
Thru	0	0	0	0	0	0	0	0	0	0	0	0	0	0	0	0	0	0	0	0	0	0	0	0	0	0														
Right	0	0	0	0	0	0	0	0	0	0	0	0	0	0	0	0	0	0	0	0	0	0	0	0	0	0														

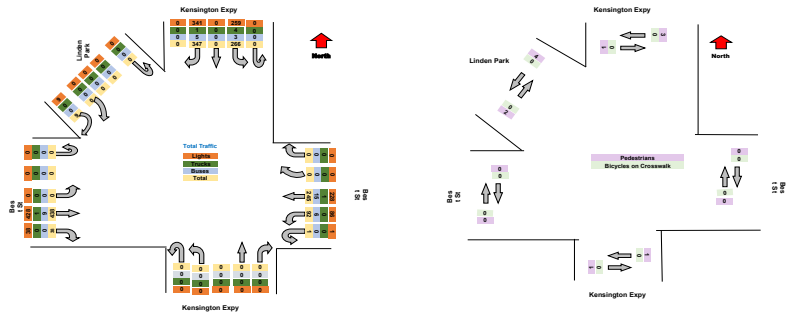

Turning Movement Peak Hour Data (PM)
4:30:00 PM

Time	Kensington Expy					Kensington Expy					Kensington Expy					Kensington Expy				
	Left	Thru	Right	Left	Thru	Right	Left	Thru	Right	Left	Thru	Right	Left	Thru	Right	Left	Thru	Right		
4:30:00 PM	1	1	1	1	1	1	1	1	1	1	1	1	1	1	1	1	1	1		
4:31:00 PM	1	1	1	1	1	1	1	1	1	1	1	1	1	1	1	1	1	1		
4:32:00 PM	1	1	1	1	1	1	1	1	1	1	1	1	1	1	1	1	1	1		
4:33:00 PM	1	1	1	1	1	1	1	1	1	1	1	1	1	1	1	1	1	1		
4:34:00 PM	1	1	1	1	1	1	1	1	1	1	1	1	1	1	1	1	1	1		
4:35:00 PM	1	1	1	1	1	1	1	1	1	1	1	1	1	1	1	1	1	1		
4:36:00 PM	1	1	1	1	1	1	1	1	1	1	1	1	1	1	1	1	1	1		
4:37:00 PM	1	1	1	1	1	1	1	1	1	1	1	1	1	1	1	1	1	1		
4:38:00 PM	1	1	1	1	1	1	1	1	1	1	1	1	1	1	1	1	1	1		
4:39:00 PM	1	1	1	1	1	1	1	1	1	1	1	1	1	1	1	1	1	1		
4:40:00 PM	1	1	1	1	1	1	1	1	1	1	1	1	1	1	1	1	1	1		
4:41:00 PM	1	1	1	1	1	1	1	1	1	1	1	1	1	1	1	1	1	1		
4:42:00 PM	1	1	1	1	1	1	1	1	1	1	1	1	1	1	1	1	1	1		
4:43:00 PM	1	1	1	1	1	1	1	1	1	1	1	1	1	1	1	1	1	1		
4:44:00 PM	1	1	1	1	1	1	1	1	1	1	1	1	1	1	1	1	1	1		
4:45:00 PM	1	1	1	1	1	1	1	1	1	1	1	1	1	1	1	1	1	1		
4:46:00 PM	1	1	1	1	1	1	1	1	1	1	1	1	1	1	1	1	1	1		
4:47:00 PM	1	1	1	1	1	1	1	1	1	1	1	1	1	1	1	1	1	1		
4:48:00 PM	1	1	1	1	1	1	1	1	1	1	1	1	1	1	1	1	1	1		
4:49:00 PM	1	1	1	1	1	1	1	1	1	1	1	1	1	1	1	1	1	1		
4:50:00 PM	1	1	1	1	1	1	1	1	1	1	1	1	1	1	1	1	1	1		
4:51:00 PM	1	1	1	1	1	1	1	1	1	1	1	1	1	1	1	1	1	1		
4:52:00 PM	1	1	1	1	1	1	1	1	1	1	1	1	1	1	1	1	1	1		
4:53:00 PM	1	1	1	1	1	1	1	1	1	1	1	1	1	1	1	1	1	1		
4:54:00 PM	1	1	1	1	1	1	1	1	1	1	1	1	1	1	1	1	1	1		
4:55:00 PM	1	1	1	1	1	1	1	1	1	1	1	1	1	1	1	1	1	1		
4:56:00 PM	1	1	1	1	1	1	1	1	1	1	1	1	1	1	1	1	1	1		
4:57:00 PM	1	1	1	1	1	1	1	1	1	1	1	1	1	1	1	1	1	1		
4:58:00 PM	1	1	1	1	1	1	1	1	1	1	1	1	1	1	1	1	1	1		
4:59:00 PM	1	1	1	1	1	1	1	1	1	1	1	1	1	1	1	1	1	1		
5:00:00 PM	1	1	1	1	1	1	1	1	1	1	1	1	1	1	1	1	1	1		

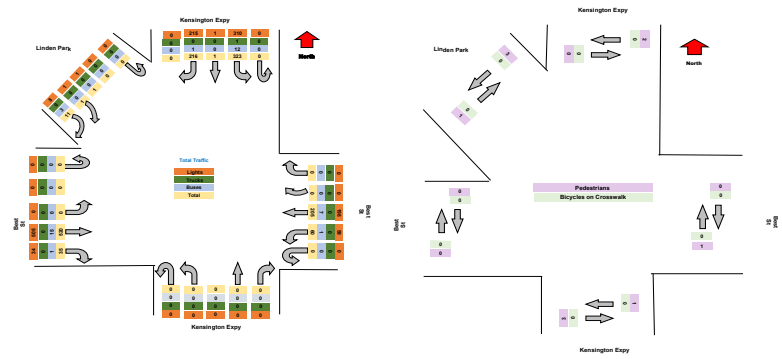

Turning Movement Data Plot

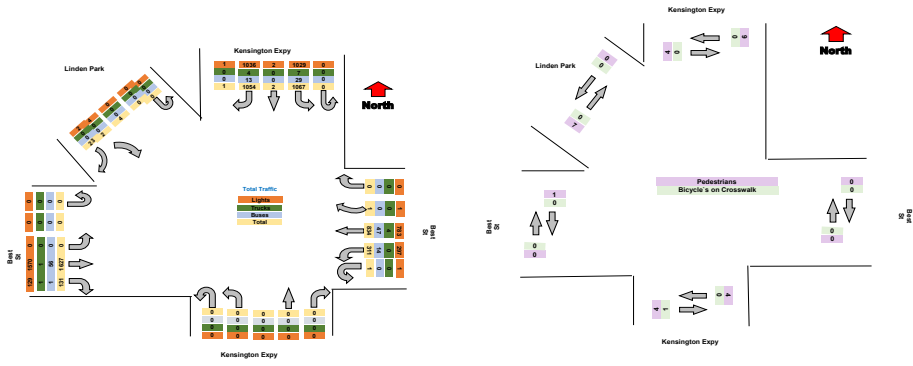



Turning Movement Peak Hour Data (AM)

7:30:00 AM

Link	Kensington Expy				North				Kensington Expy				South				Linden Park			
	Left	Thru	Right	Other	Left	Thru	Right	Other	Left	Thru	Right	Other	Left	Thru	Right	Other	Left	Thru	Right	Other
Volume	10	10	10	10	10	10	10	10	10	10	10	10	10	10	10	10	10	10	10	10
Weighted Volume	10	10	10	10	10	10	10	10	10	10	10	10	10	10	10	10	10	10	10	10
Control
...

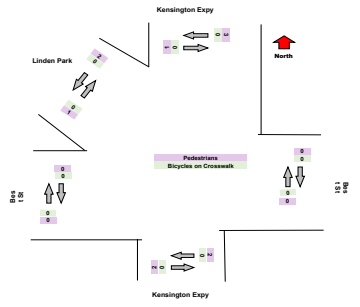
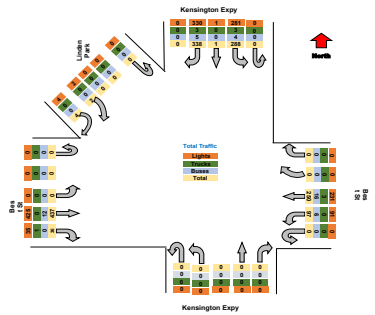

Turning Movement Peak Hour Data (PM)
4:30:00 PM

Link	Kensington Expy				Kensington Expy				Kensington Expy				Kensington Expy			
	Left	Thru	Right	Other	Left	Thru	Right	Other	Left	Thru	Right	Other	Left	Thru	Right	Other
Link ID	101	102	103	104	105	106	107	108	109	110	111	112	113	114	115	116
Link Name
Link Type
Link Length
Link Speed
Link Volume
Link Capacity
Link Utilization

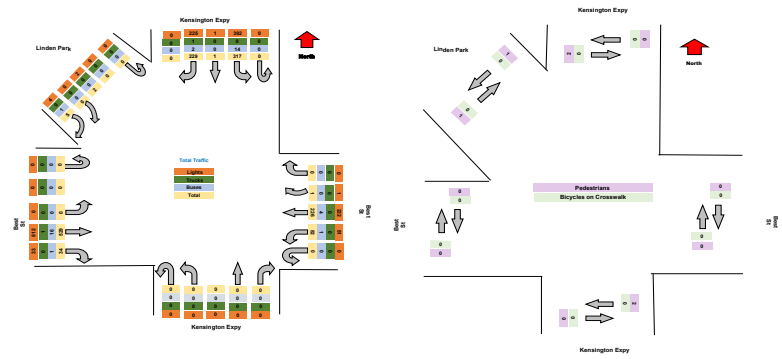

Project:	11160600
File Name:	20210828
Site Name:	11160600 - Kennett Square, PA
File Path:	\\tstdata.com\11160600 - Kennett Square, PA
File Name:	11160600 - Kennett Square, PA
File Path:	\\tstdata.com\11160600 - Kennett Square, PA
File Name:	11160600 - Kennett Square, PA
File Path:	\\tstdata.com\11160600 - Kennett Square, PA
File Name:	11160600 - Kennett Square, PA
File Path:	\\tstdata.com\11160600 - Kennett Square, PA

Turning Movement Data

Link	Approach				Main				Main				Main				Total
	Thru	Left	Right	Other	Thru	Left	Right	Other	Thru	Left	Right	Other	Thru	Left	Right	Other	
Elm St - Pine St	111	0	0	0	111	0	0	0	111	0	0	0	111	0	0	0	111
Pine St - Elm St	0	0	111	0	0	0	111	0	0	0	0	111	0	0	0	0	111
Elm St - Pine St	111	0	0	0	111	0	0	0	111	0	0	0	111	0	0	0	111
Pine St - Elm St	0	0	111	0	0	0	111	0	0	0	0	111	0	0	0	0	111
Elm St - Pine St	111	0	0	0	111	0	0	0	111	0	0	0	111	0	0	0	111
Pine St - Elm St	0	0	111	0	0	0	111	0	0	0	0	111	0	0	0	0	111
Elm St - Pine St	111	0	0	0	111	0	0	0	111	0	0	0	111	0	0	0	111
Pine St - Elm St	0	0	111	0	0	0	111	0	0	0	0	111	0	0	0	0	111

Turning Movement Data Plot

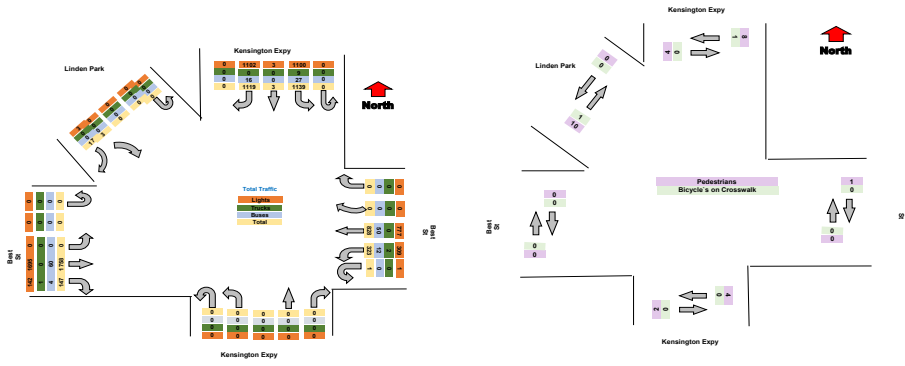



Turning Movement Peak Hour Data (AM)

7:30:00 AM

Link	Kensington Expy												North												Kensington Expy												Linden Park											
	Kensington Expy				North				Kensington Expy				North				Kensington Expy				North				Kensington Expy				North																			
Direction	Left	Thru	Right	Total	Left	Thru	Right	Total	Left	Thru	Right	Total	Left	Thru	Right	Total	Left	Thru	Right	Total	Left	Thru	Right	Total	Left	Thru	Right	Total																				
Approach	Linden Park												Kensington Expy												Kensington Expy												North											
Left	0												0												0												0											
Thru	0												0												0												0											
Right	0												0												0												0											
Total	0												0												0												0											
Approach	Kensington Expy												North												Kensington Expy												Linden Park											
Left	0												0												0												0											
Thru	0												0												0												0											
Right	0												0												0												0											
Total	0												0												0												0											

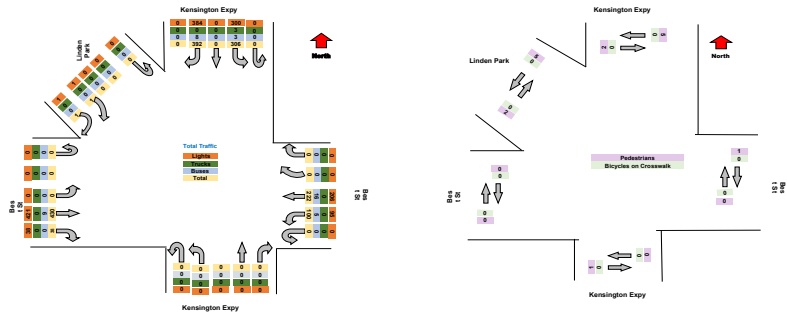

Turning Movement Peak Hour Data (PM)
4:30:00 PM

Link	Kensington Expy						Kensington Expy						Kensington Expy						Kensington Expy					
	W	SW	S	SE	E	NE	W	SW	S	SE	E	NE	W	SW	S	SE	E	NE	W	SW	S	SE	E	NE
Left	21	1	1	1	1	1	1	1	1	1	1	1	1	1	1	1	1	1	1	1	1	1	1	1
Thru	1	1	1	1	1	1	1	1	1	1	1	1	1	1	1	1	1	1	1	1	1	1	1	1
Right	1	1	1	1	1	1	1	1	1	1	1	1	1	1	1	1	1	1	1	1	1	1	1	1
Total	23	3	3	3	3	3	3	3	3	3	3	3	3	3	3	3	3	3	3	3	3	3	3	

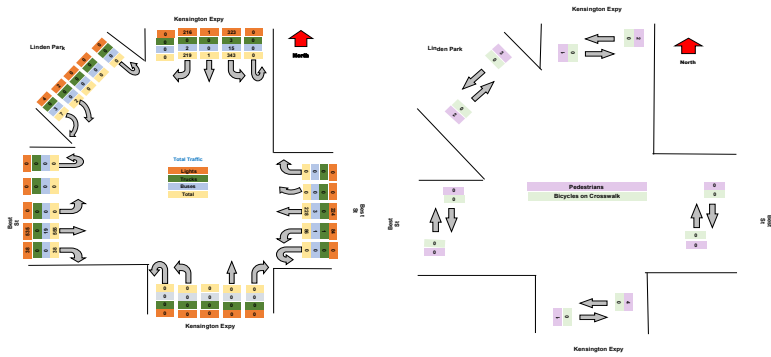

Turning Movement Data Plot

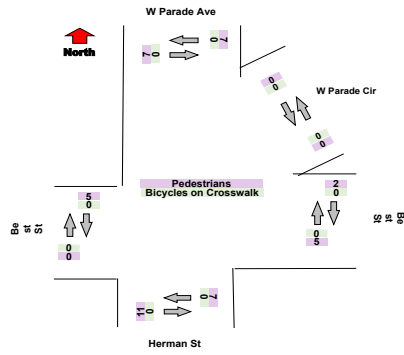
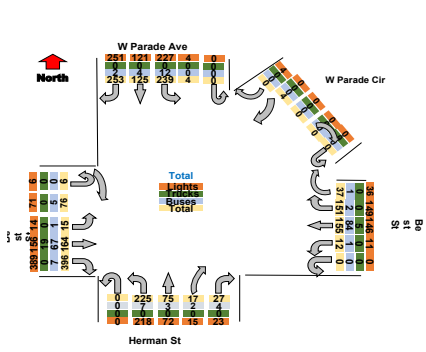

Turning Movement Peak Hour Data (AM)

7:30:00 AM

Link	Direction				Direction				Direction				Direction			
	Left		Thru		Left		Thru		Left		Thru		Left		Thru	
	Observed	Sat	Observed	Sat	Observed	Sat	Observed	Sat	Observed	Sat	Observed	Sat	Observed	Sat	Observed	Sat
W Parade Ave	0	0	0	0	0	0	0	0	0	0	0	0	0	0	0	0
Herman St	0	0	0	0	0	0	0	0	0	0	0	0	0	0	0	0
W Parade Cir	0	0	0	0	0	0	0	0	0	0	0	0	0	0	0	0
...

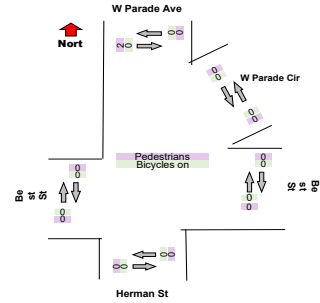
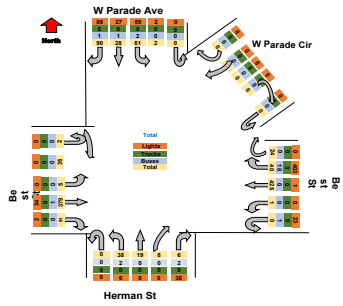

Turning Movement Peak Hour Data (PM)

4:15:00 PM

Link	W Parade Ave				Herman St				Beech St				Pine St			
	1	2	3	4	1	2	3	4	1	2	3	4	1	2	3	4
Volume	11	11	11	11	11	11	11	11	11	11	11	11	11	11	11	11
Light	11	11	11	11	11	11	11	11	11	11	11	11	11	11	11	11
Heavy	11	11	11	11	11	11	11	11	11	11	11	11	11	11	11	11
Total	11	11	11	11	11	11	11	11	11	11	11	11	11	11	11	11

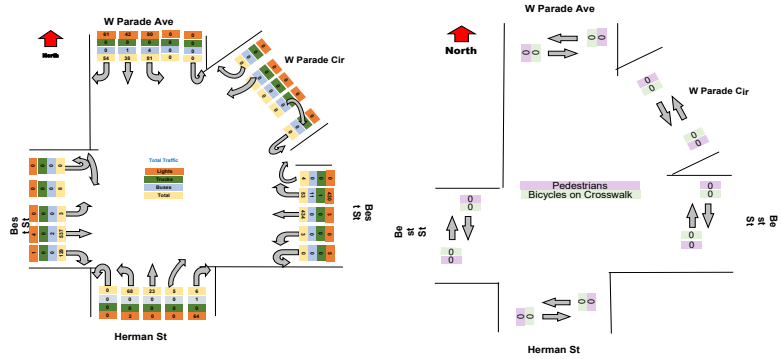

Intersection: Elm St Pine St
 Location: Kennett Square, PA
 Site: 01
 Survey Date: Wednesday, 04-28-2021
 GPS: 42.948550, -72.790034

Category	Value
Project Name	010000
Site No	01
Site Name	0100000001
Site Address	0100000001
Site City	0100000001
Site State	0100000001
Site Zip	0100000001
Site County	0100000001
Site District	0100000001
Site Sector	0100000001
Site Subsector	0100000001
Site Division	0100000001
Site Office	0100000001
Site Manager	0100000001
Site Operator	0100000001
Site Contact	0100000001
Site Phone	0100000001
Site Email	0100000001
Site Fax	0100000001
Site Web	0100000001

Turning Movement Data

ID	Direction	Phase 1					Phase 2					Phase 3					Phase 4					Total					
		W	Th	F	Sa	Su	W	Th	F	Sa	Su	W	Th	F	Sa	Su	W	Th	F	Sa	Su						
1	North																										
2	South																										
3	East																										
4	West																										

Turning Movement Data Plot

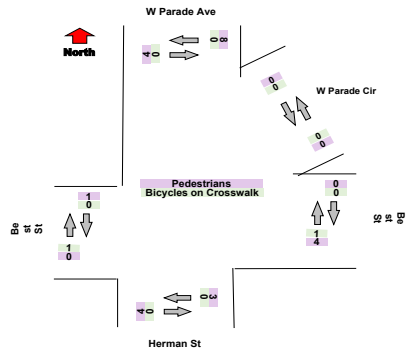
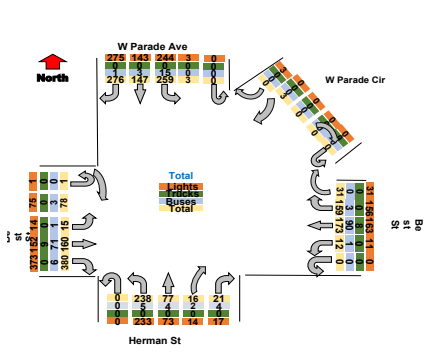

Turning Movement Peak Hour Data (AM)

7:30:00 AM

Link	W Parade Ave				Herman St				W Parade Cir				Pine St			
	Flow	Vol	Sat	Opp	Flow	Vol	Sat	Opp	Flow	Vol	Sat	Opp	Flow	Vol	Sat	Opp
W Parade Ave	1	0	0	0	1	0	0	0	1	0	0	0	1	0	0	0
Herman St	1	0	0	0	1	0	0	0	1	0	0	0	1	0	0	0
W Parade Cir	1	0	0	0	1	0	0	0	1	0	0	0	1	0	0	0
Pine St	1	0	0	0	1	0	0	0	1	0	0	0	1	0	0	0

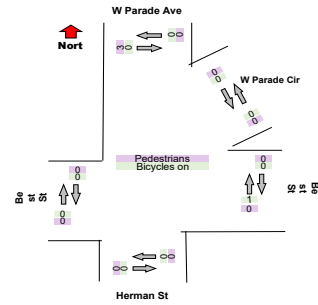
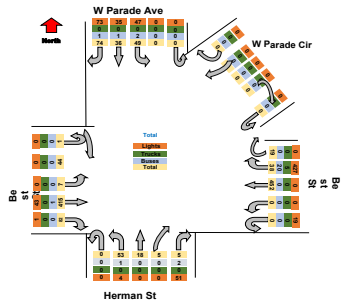

Turning Movement Peak Hour Data (PM)
 4:15:00 PM

Link	W Parade Ave				Herman St				Beech St				Pine St			
	TH	TR	TR	TH	TH	TR	TR	TH	TH	TR	TR	TH	TR	TR	TH	
W Parade Ave	12	12	12	12	12	12	12	12	12	12	12	12	12	12	12	
Herman St	12	12	12	12	12	12	12	12	12	12	12	12	12	12	12	
Beech St	12	12	12	12	12	12	12	12	12	12	12	12	12	12	12	
Pine St	12	12	12	12	12	12	12	12	12	12	12	12	12	12	12	

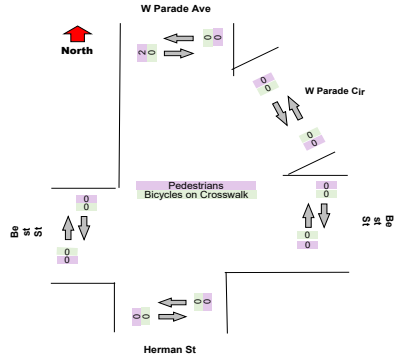
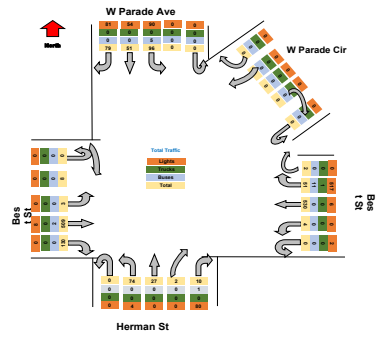

Turning Movement Data Plot

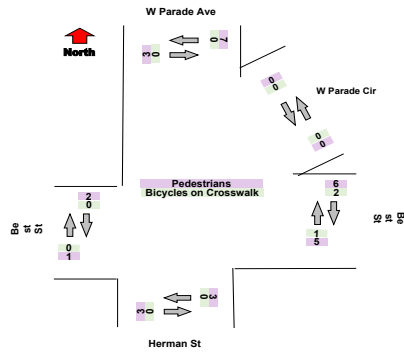
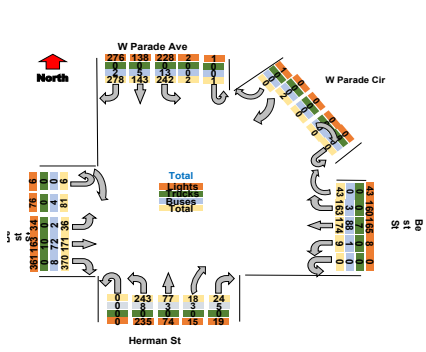

Turning Movement Peak Hour Data (AM)

7:30:00 AM

Link	W Parade Ave				Herman St				W Parade Cir				Pine St			
	Flow	Vol	Sat	Stop	Flow	Vol	Sat	Stop	Flow	Vol	Sat	Stop	Flow	Vol	Sat	Stop
W Parade Ave	1	0	0	0	1	0	0	0	1	0	0	0	1	0	0	0
Herman St	1	0	0	0	1	0	0	0	1	0	0	0	1	0	0	0
W Parade Cir	1	0	0	0	1	0	0	0	1	0	0	0	1	0	0	0
Pine St	1	0	0	0	1	0	0	0	1	0	0	0	1	0	0	0

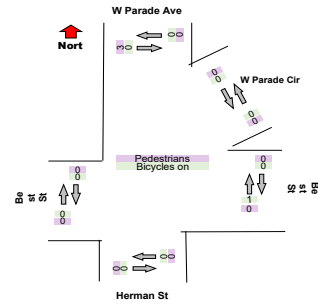
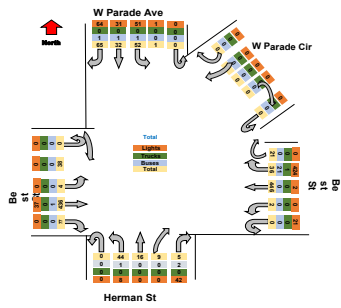

Turning Movement Peak Hour Data (PM)
 4:15:00 PM

Link	W Parade Ave				Herman St				Beech St				Pine St			
	1	2	3	4	1	2	3	4	1	2	3	4	1	2	3	4
Volume	12	12	12	12	12	12	12	12	12	12	12	12	12	12	12	12
Light	12	12	12	12	12	12	12	12	12	12	12	12	12	12	12	12
Heavy	12	12	12	12	12	12	12	12	12	12	12	12	12	12	12	12
Total	12	12	12	12	12	12	12	12	12	12	12	12	12	12	12	12

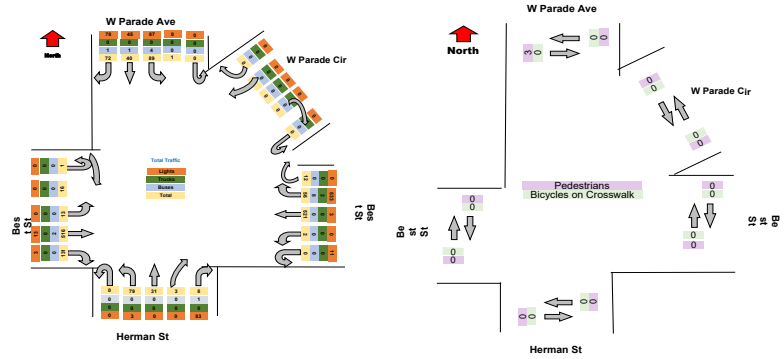

Project : VBH Malta NY
Site : Site 4
Location : 42.948550, -73.790036

TSTData.com

Survey Date : 2021-04-28, Wednesday

Project	Labella
Project Code	Labella
Site Name	4
Legs and Movements	All Processed Legs & Move
Bin Size	15 minutes
Survey Date	2021-10-26, Tuesday
Location	4
Latitude and Longitude	42.907341, -78.844225

	Start	End	PHF
Forced Peak AM	2021/10/26 07:30:00	2021/10/26 08:30:00	0.88
Forced Peak PM	2021/10/26 16:30:00	2021/10/26 17:30:00	0.92
AM Peak	2021/10/26 07:30:00	2021/10/26 08:30:00	0.88
PM Peak	2021/10/26 16:15:00	2021/10/26 17:15:00	0.96

Turning Movement Data

Leg Direction	Humboldt Pkwy								Northampton St								Humboldt Pkwy								Northampton St								Total	
	Southbound				Northbound				Westbound				Eastbound				Northbound				Eastbound													
	Right	Thru	Left	U-Turn	App Total	Peds CV	Peds CCV		Right	Thru	Left	U-Turn	App Total	Peds CV	Peds CCV		Right	Thru	Left	U-Turn	App Total	Peds CV	Peds CCV		Right	Thru	Left	U-Turn	App Total	Peds CV	Peds CCV			
6:30:00 AM	5	10	7	0	22	1	0	0	0	2	1	0	3	0	0	0	0	0	0	0	0	0	0	0	0	0	0	0	0	0	0	0	30	
6:45:00 AM	5	9	7	0	21	0	0	0	0	8	1	0	9	0	0	0	0	0	0	0	0	0	0	0	0	0	0	0	0	0	0	0	33	
Hourly Total	10	19	14	0	43	1	0	0	0	10	2	0	12	0	0	0	0	0	0	0	0	0	0	0	0	0	0	0	0	0	0	0	63	
7:00:00 AM	14	9	8	0	21	0	0	0	0	8	2	0	10	0	0	0	0	0	0	0	0	0	0	0	0	0	0	0	0	0	0	0	37	
7:15:00 AM	2	6	8	0	16	0	0	0	0	14	3	0	17	0	0	0	0	0	0	0	0	0	0	0	0	0	0	0	0	0	0	0	38	
7:30:00 AM	2	11	17	0	30	2	0	0	0	5	3	0	8	0	0	0	0	0	0	0	0	0	0	0	1	11	0	0	12	1	1	0	50	
7:45:00 AM	2	21	13	0	36	0	0	0	0	18	4	0	22	0	0	0	0	0	0	0	0	0	0	0	2	1	13	0	14	0	0	0	72	
Hourly Total	10	47	46	0	103	2	0	0	0	45	12	0	57	0	0	0	0	0	0	0	0	0	0	0	2	35	0	0	37	1	1	0	197	
8:00:00 AM	8	14	9	0	29	0	1	0	0	15	5	0	21	0	1	0	0	0	0	0	1	0	2	0	0	20	0	0	20	0	0	0	71	
8:15:00 AM	4	14	13	0	31	0	0	0	0	13	1	0	14	0	0	0	0	0	0	0	0	0	0	0	0	15	0	0	15	0	0	0	60	
Hourly Total	10	28	22	0	60	0	1	0	0	28	6	0	35	0	1	0	0	0	0	0	1	0	2	0	0	35	0	0	35	0	0	0	131	
4:00:00 PM	8	26	25	0	59	0	1	0	0	13	3	0	16	0	0	0	0	0	0	0	0	0	0	0	1	23	0	0	24	0	0	0	99	
4:15:00 PM	8	24	22	0	54	0	0	0	0	12	3	0	15	0	1	0	0	0	0	0	0	0	0	0	0	23	0	0	23	0	0	0	92	
4:30:00 PM	7	26	17	0	50	0	0	0	0	17	4	0	21	0	0	0	0	0	0	0	0	0	0	0	0	21	0	0	21	0	1	0	92	
4:45:00 PM	7	20	23	0	47	0	0	0	0	17	2	0	19	0	0	0	0	0	0	0	0	0	0	0	1	18	0	0	19	1	0	0	85	
Hourly Total	30	96	84	0	210	0	3	0	0	59	12	0	71	0	1	0	0	0	0	0	0	0	0	0	2	85	0	0	87	1	1	0	368	
5:00:00 PM	5	22	12	0	39	0	0	0	0	22	2	0	24	1	0	0	0	0	0	0	0	0	0	0	1	21	0	0	22	0	0	0	85	
5:15:00 PM	3	21	20	0	44	0	0	0	0	14	4	0	18	0	0	0	0	0	0	0	0	0	0	0	0	14	0	0	14	0	0	0	76	
5:30:00 PM	8	15	19	0	42	0	0	0	0	17	3	0	20	0	0	0	0	0	0	0	0	0	0	0	1	15	0	0	16	0	0	0	78	
5:45:00 PM	6	13	12	0	31	1	0	0	0	15	1	0	16	1	0	0	0	0	0	0	0	0	0	0	0	10	0	0	10	0	0	0	57	
Hourly Total	22	71	63	0	156	1	0	0	0	68	10	0	78	2	0	0	0	0	0	0	0	0	0	0	2	60	0	0	62	0	0	0	296	
Grand Total	82	281	229	0	572	4	4	0	0	210	42	0	253	2	2	0	0	0	0	0	1	2	5	0	7	222	0	0	229	2	2	0	1085	
% Approach	14.3%	45.6%	40.0%	0.0%	0.0%	0.0%	0.0%	0.0%	0.0%	83.0%	16.6%	0.0%	0.0%	0.0%	0.0%	0.0%	0.0%	0.0%	0.0%	0.0%	0.0%	0.0%	0.0%	0.0%	0.0%	3.1%	96.9%	0.0%	0.0%	0.0%	0.0%	0.0%	0.0%	0.0%
% Total	7.8%	24.7%	21.7%	0.0%	54.2%	0.0%	0.0%	0.0%	0.0%	19.9%	4.0%	0.0%	24.0%	0.0%	0.0%	0.0%	0.0%	0.0%	0.0%	0.0%	0.1%	0.0%	0.0%	0.0%	0.7%	21.0%	0.0%	0.0%	21.7%	0.0%	0.0%	0.0%	0.0%	
Lights	77	245	219	0	541	0	0	0	0	206	39	0	245	0	0	0	0	0	0	0	0	0	0	0	0	6	213	0	0	219	0	0	0	1005
% Lights	93.3%	93.9%	95.9%	0.0%	94.8%	0.0%	0.0%	0.0%	0.0%	98.1%	92.9%	0.0%	98.8%	0.0%	0.0%	0.0%	0.0%	0.0%	0.0%	0.0%	0.0%	0.0%	0.0%	0.0%	0.0%	85.7%	95.9%	0.0%	0.0%	95.8%	0.0%	0.0%	0.0%	95.3%
Trucks	0	0	0	0	0	0	0	0	0	0	0	0	0	0	0	0	0	0	0	0	0	0	0	0	0	0	0	0	0	0	0	0	0	
% Trucks	0.0%	0.0%	0.0%	0.0%	0.0%	0.0%	0.0%	0.0%	0.0%	0.0%	0.0%	0.0%	0.0%	0.0%	0.0%	0.0%	0.0%	0.0%	0.0%	0.0%	0.0%	0.0%	0.0%	0.0%	0.0%	0.0%	0.0%	0.0%	0.0%	0.0%	0.0%	0.0%	0.0%	
Buses	5	16	10	0	31	0	0	0	0	4	3	0	7	0	0	0	0	0	0	0	0	0	0	0	0	1	9	0	0	10	0	0	0	48
% Buses	6.1%	6.1%	4.4%	0.0%	0.0%	0.0%	0.0%	0.0%	0.0%	1.9%	7.1%	0.0%	0.0%	0.0%	0.0%	0.0%	0.0%	0.0%	0.0%	0.0%	0.0%	0.0%	0.0%	0.0%	0.0%	14.3%	4.1%	0.0%	0.0%	0.0%	0.0%	0.0%	0.0%	4.5%
Pedestrians	0	0	0	0	0	4	3	0	0	0	0	0	0	2	2	0	0	0	0	0	0	0	0	0	0	0	0	0	0	2	2	0	0	
% Pedestrians	0.0%	0.0%	0.0%	0.0%	0.0%	100.0%	75.0%	0.0%	0.0%	0.0%	0.0%	0.0%	0.0%	100.0%	100.0%	0.0%	0.0%	0.0%	0.0%	0.0%	0.0%	0.0%	0.0%	0.0%	0.0%	0.0%	0.0%	0.0%	0.0%	100.0%	100.0%	0.0%	0.0%	
Bicycles on Crosswalk	0	0	0	0	0	0	1	0	0	0	0	0	0	0	0	0	0	0	0	0	0	0	0	0	0	0	0	0	0	0	0	0	0	
% Bicycles on Crosswalk	0.0%	0.0%	0.0%	0.0%	0.0%	0.0%	25.0%	0.0%	0.0%	0.0%	0.0%	0.0%	0.0%	0.0%	0.0%	0.0%	0.0%	0.0%	0.0%	0.0%	0.0%	0.0%	0.0%	0.0%	0.0%	0.0%	0.0%	0.0%	0.0%	0.0%	0.0%	0.0%	0.0%	

Project : VBH Malta NY
 Site : Site 4
 Location : 42.948550, -73.790036
 Survey Date : 2021-04-28, Wednesday

Turning Movement Data Plot

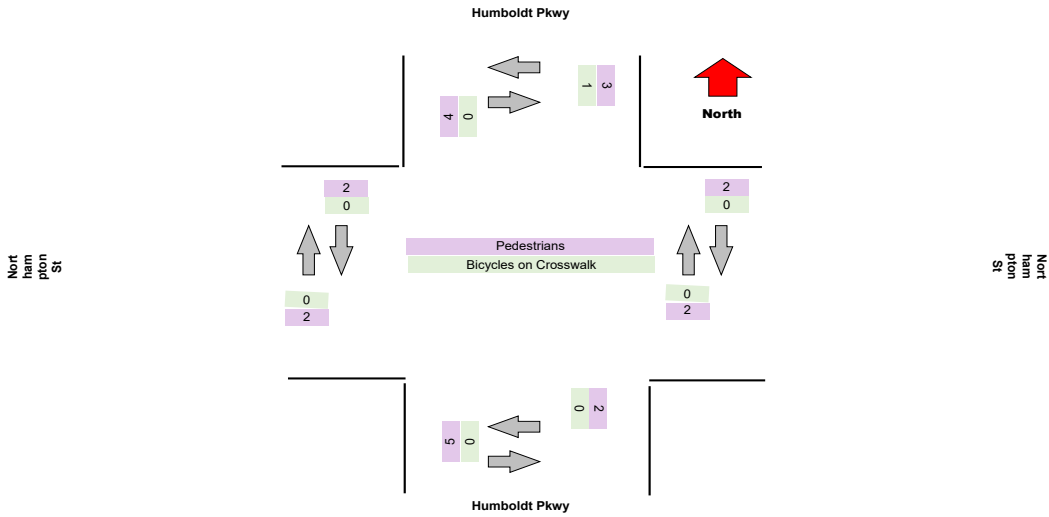
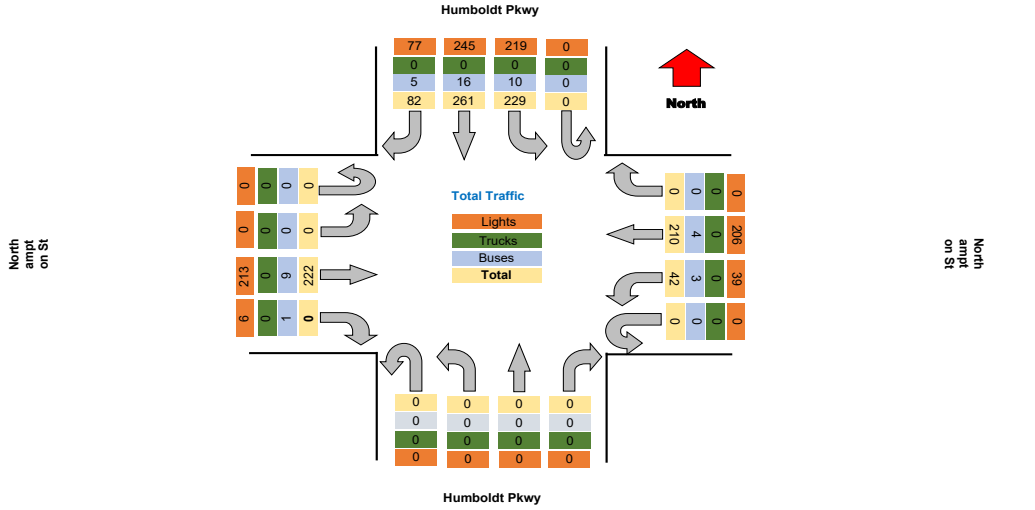

Turning Movement Peak Hour Data (AM)

7:30:00 AM

Leg Direction	Humboldt Pkwy						Northampton St						Humboldt Pkwy						Northampton St						Total						
	Southbound			Northbound			Westbound			Eastbound			Northbound			Eastbound															
Start Time	Right	Thru	Left	U-Turn	App Total	Peds CW	Peds CCW	Right	Thru	Left	U-Turn	App Total	Peds CW	Peds CCW	Right	Thru	Left	U-Turn	App Total	Peds CW	Peds CCW	Right	Thru	Left	U-Turn	App Total	Peds CW	Peds CCW			
7:30:00 AM	2	11	17	0	30	2	0	0	5	3	0	8	0	0	0	0	0	0	0	0	0	0	1	11	0	0	12	1	1	50	
7:45:00 AM	2	21	13	0	36	0	0	0	18	4	0	22	0	0	0	0	0	0	0	0	0	0	1	13	0	0	14	0	0	72	
8:00:00 AM	6	14	9	0	29	0	1	0	15	5	0	21	0	1	0	0	0	0	0	0	0	1	0	20	0	0	20	0	0	71	
8:15:00 AM	4	14	13	0	31	0	0	0	13	1	0	14	0	0	0	0	0	0	0	0	0	0	0	15	0	0	15	0	0	60	
Grand Total	14	60	52	0	126	2	1	0	51	13	0	65	0	1	0	0	0	0	0	0	0	1	2	2	59	0	0	61	1	1	253
% Approach	11.1%	47.6%	41.3%	0.0%	0.0%	0.0%	0.0%	14.2%	85.8%	0.0%	0.0%	0.0%	0.0%	0.0%	45.1%	41.7%	13.2%	0.0%	0.0%	0.0%	0.0%	0.0%	0.0%	66.2%	33.8%	0.0%	0.0%	0.0%	0.0%	0.0%	
% Total	5.5%	23.7%	20.6%	0.0%	48.8%	0.0%	0.0%	0.0%	20.2%	5.1%	0.0%	25.7%	0.0%	0.0%	0.0%	0.0%	0.0%	0.0%	0.4%	0.0%	0.0%	0.0%	0.8%	23.3%	0.0%	0.0%	24.1%	0.0%	0.0%	0.0%	
PHF	0.583	0.714	0.765	0.000	0.875	0.000	0.000	0.000	0.708	0.650	0.000	0.739	0.000	0.000	0.000	0.000	0.000	0.000	0.250	0.000	0.000	0.500	0.738	0.000	0.000	0.763	0.000	0.000	0.878		
Lights	13	55	48	0	116	0	0	0	49	12	0	61	0	0	0	0	0	0	0	0	0	0	2	55	0	0	57	0	0	234	
% Lights	82.9%	91.7%	92.3%	0.0%	92.1%	0.0%	0.0%	0.0%	96.1%	92.3%	0.0%	93.8%	0.0%	0.0%	0.0%	0.0%	0.0%	0.0%	0.0%	0.0%	0.0%	0.0%	100.0%	93.2%	0.0%	0.0%	93.4%	0.0%	0.0%	92.5%	
Trucks	0	0	0	0	0	0	0	0	0	0	0	0	0	0	0	0	0	0	0	0	0	0	0	0	0	0	0	0	0	0	
% Trucks	0.0%	0.0%	0.0%	0.0%	0.0%	0.0%	0.0%	0.0%	0.0%	0.0%	0.0%	0.0%	0.0%	0.0%	0.0%	0.0%	0.0%	0.0%	0.0%	0.0%	0.0%	0.0%	0.0%	0.0%	0.0%	0.0%	0.0%	0.0%	0.0%	0.0%	
Buses	1	5	4	0	10	0	0	0	2	1	0	3	0	0	0	0	0	0	0	0	0	0	0	4	0	0	4	0	0	17	
% Buses	7.1%	8.3%	7.7%	0.0%	0.0%	0.0%	0.0%	0.0%	3.9%	7.7%	0.0%	0.0%	0.0%	0.0%	0.0%	0.0%	0.0%	0.0%	0.0%	0.0%	0.0%	0.0%	0.0%	6.8%	0.0%	0.0%	0.0%	0.0%	0.0%	6.7%	
Pedestrians	0	0	0	0	0	2	0	0	0	0	0	0	1	0	0	0	0	0	0	2	3	0	0	0	0	0	0	1	1	0	
% Pedestrians	0.0%	0.0%	0.0%	0.0%	0.0%	100.0%	0.0%	0.0%	0.0%	0.0%	0.0%	0.0%	0.0%	0.0%	0.0%	0.0%	0.0%	0.0%	0.0%	0.0%	0.0%	0.0%	0.0%	0.0%	0.0%	0.0%	0.0%	0.0%	100.0%	100.0%	0.0%
Bicycles on Crosswalk	0	0	0	0	0	0	0	0	0	0	0	0	0	0	0	0	0	0	0	0	0	0	0	0	0	0	0	0	0	0	
% Bicycles on Crosswalk	0.0%	0.0%	0.0%	0.0%	0.0%	0.0%	0.0%	0.0%	0.0%	0.0%	0.0%	0.0%	0.0%	0.0%	0.0%	0.0%	0.0%	0.0%	0.0%	0.0%	0.0%	0.0%	0.0%	0.0%	0.0%	0.0%	0.0%	0.0%	0.0%	0.0%	

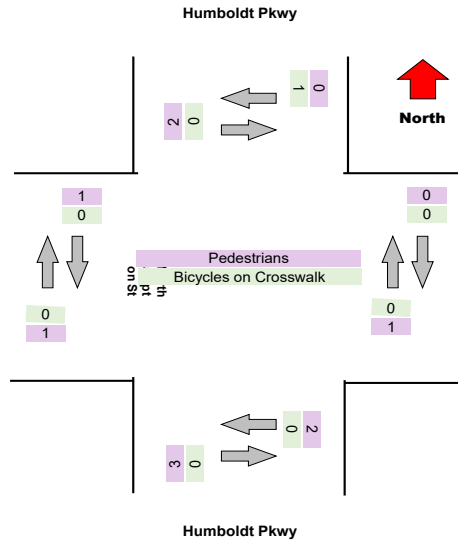
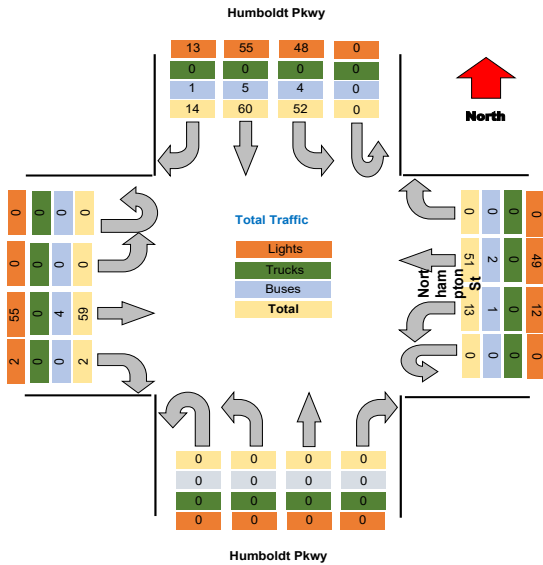

Turning Movement Peak Hour Data (PM)

4:15:00 PM

Leg Direction	Humboldt Pkwy				Northampton St				Humboldt Pkwy				Northampton St				Total					
	Southbound		Northbound		Westbound		Eastbound		Northbound		Southbound		Eastbound									
Start Time	Right	Thru	Left	U-Turn	App Total	Peds CW	Peds CCW	Right	Thru	Left	U-Turn	App Total	Peds CW	Peds CCW	Right	Thru	Left	U-Turn	App Total	Peds CW	Peds CCW	
4:15:00 PM	8	24	22	0	54	0	0	0	12	3	0	15	0	0	0	0	0	0	0	0	0	0
4:30:00 PM	7	26	17	0	50	0	0	0	17	4	0	21	0	0	0	0	0	0	0	0	0	0
4:45:00 PM	7	20	20	0	47	0	0	0	17	2	0	19	0	0	0	0	0	0	0	0	0	0
5:00:00 PM	5	22	12	0	39	0	0	0	22	2	0	24	0	0	0	0	0	0	0	0	0	0
Grand Total	27	92	71	0	190	0	0	0	69	11	0	79	0	0	0	0	0	0	0	0	0	0
% Approach	14.2%	48.4%	37.4%	0.0%	0.0%	0.0%	0.0%	14.2%	85.8%	0.0%	0.0%	0.0%	0.0%	0.0%	45.1%	41.7%	13.2%	0.0%	0.0%	0.0%	0.0%	0.0%
% Total	7.6%	26.0%	20.1%	0.0%	53.7%	0.0%	0.0%	0.0%	19.2%	3.1%	0.0%	22.3%	0.0%	0.0%	0.0%	0.0%	0.0%	0.0%	0.0%	0.0%	0.0%	0.0%
PHF	0.844	0.885	0.807	0.000	0.890	0.000	0.000	0.000	0.773	0.688	0.000	0.823	0.000	0.000	0.000	0.000	0.000	0.000	0.000	0.000	0.000	0.000
Lights	25	86	70	0	181	0	0	0	67	11	0	78	0	0	0	0	0	0	0	0	0	0
% Lights	92.6%	93.5%	98.6%	0.0%	95.3%	0.0%	0.0%	0.0%	98.5%	100.0%	0.0%	98.7%	0.0%	0.0%	0.0%	0.0%	0.0%	0.0%	0.0%	0.0%	0.0%	0.0%
Trucks	0	0	0	0	0	0	0	0	0	0	0	0	0	0	0	0	0	0	0	0	0	0
% Trucks	0.0%	0.0%	0.0%	0.0%	0.0%	0.0%	0.0%	0.0%	0.0%	0.0%	0.0%	0.0%	0.0%	0.0%	0.0%	0.0%	0.0%	0.0%	0.0%	0.0%	0.0%	0.0%
Buses	2	6	1	0	9	0	0	0	1	0	0	1	0	0	0	0	0	0	0	0	0	0
% Buses	7.4%	6.5%	1.4%	0.0%	0.0%	0.0%	0.0%	0.0%	1.5%	0.0%	0.0%	0.0%	0.0%	0.0%	0.0%	0.0%	0.0%	0.0%	0.0%	0.0%	0.0%	0.0%
Pedestrians	0	0	0	0	0	0	0	0	2	0	0	1	1	0	0	0	0	0	0	0	0	0
% Pedestrians	0.0%	0.0%	0.0%	0.0%	0.0%	0.0%	100.0%	0.0%	0.0%	0.0%	0.0%	0.0%	100.0%	100.0%	0.0%	0.0%	0.0%	0.0%	0.0%	0.0%	100.0%	100.0%
Bicycles on Crosswalk	0	0	0	0	0	0	0	0	0	0	0	0	0	0	0	0	0	0	0	0	0	0
% Bicycles on Crosswalk	0.0%	0.0%	0.0%	0.0%	0.0%	0.0%	0.0%	0.0%	0.0%	0.0%	0.0%	0.0%	0.0%	0.0%	0.0%	0.0%	0.0%	0.0%	0.0%	0.0%	0.0%	0.0%

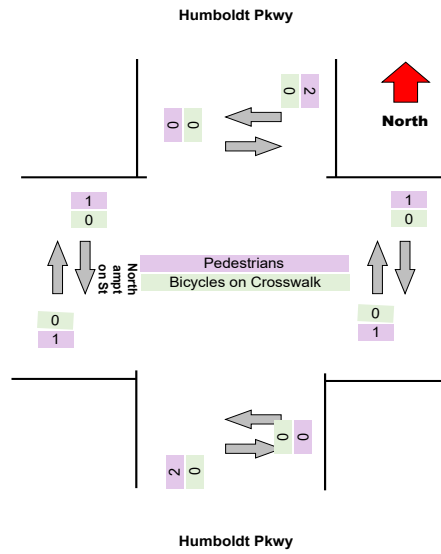
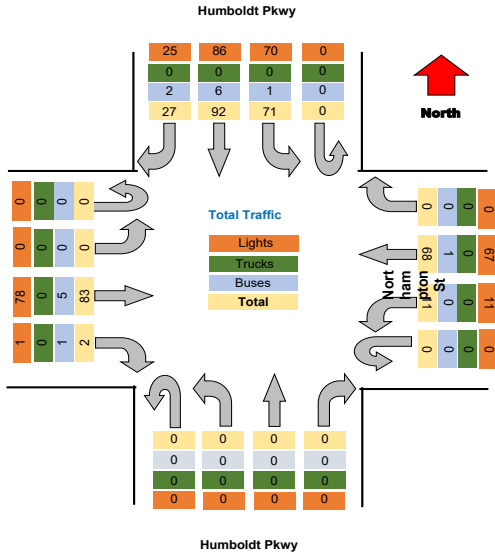

Project : VBH Malta NY
 Site : Site 4
 Location : 42.948550, -73.790036
 Survey Date : 2021-04-28, Wednesday

Turning Movement Data Plot

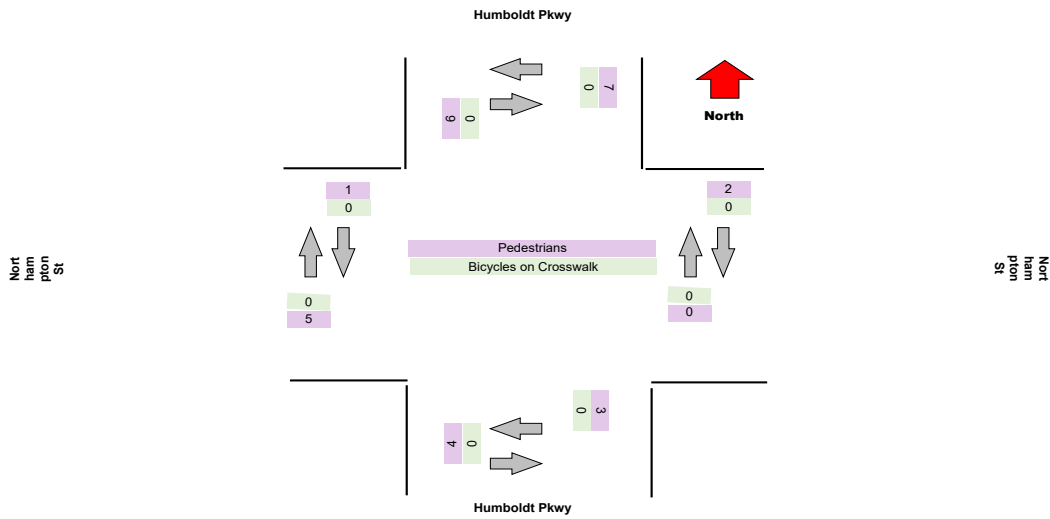
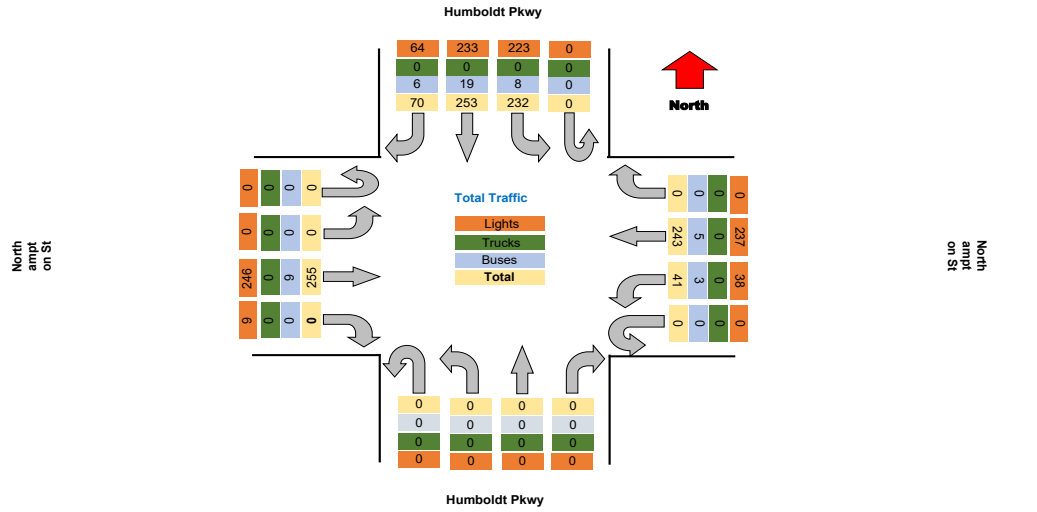

Project : VBH Malta NY
Site : Site 4
Location : 42.948550, -73.790036

TSTData.com

Survey Date : 2021-04-28, Wednesday

Turning Movement Peak Hour Data (AM)

7:30:00 AM

Leg Direction	Humboldt Pkwy						Northampton St						Humboldt Pkwy						Northampton St						Total					
	Southbound			Northbound			Westbound			Eastbound			Northbound			Eastbound														
Start Time	Right	Thru	Left	U-Turn	App Total	Peds CW	Peds CCW	Right	Thru	Left	U-Turn	App Total	Peds CW	Peds CCW	Right	Thru	Left	U-Turn	App Total	Peds CW	Peds CCW	Right	Thru	Left	U-Turn	App Total	Peds CW	Peds CCW		
7:30:00 AM	1	4	8	0	13	2	0	0	12	0	0	12	0	0	0	0	0	0	0	0	0	0	0	6	0	0	6	0	0	31
7:45:00 AM	6	20	16	0	42	0	0	0	15	2	0	17	0	0	0	0	0	0	0	0	0	0	0	18	0	0	18	1	0	77
8:00:00 AM	8	16	14	0	38	0	0	0	16	2	0	18	0	0	0	0	0	0	0	0	0	0	1	14	0	0	15	1	0	71
8:15:00 AM	5	12	22	0	39	0	0	0	7	1	0	8	0	0	0	0	0	0	0	0	0	0	0	15	0	0	15	0	0	63
Grand Total	20	52	60	0	132	2	0	0	50	5	0	55	0	0	0	0	0	0	0	0	0	0	1	53	0	0	54	2	0	242
% Approach	15.2%	39.4%	45.5%	0.0%	0.0%	0.0%	0.0%	14.2%	85.8%	0.0%	0.0%	0.0%	0.0%	0.0%	45.1%	41.7%	13.2%	0.0%	0.0%	0.0%	0.0%	0.0%	0.0%	66.2%	33.8%	0.0%	0.0%	0.0%	0.0%	0.0%
% Total	8.3%	21.5%	24.8%	0.0%	54.5%	0.0%	0.0%	0.0%	20.7%	2.1%	0.0%	23.1%	0.0%	0.0%	0.0%	0.0%	0.0%	0.0%	0.0%	0.0%	0.0%	0.0%	0.4%	21.9%	0.0%	0.0%	22.3%	0.0%	0.0%	0.0%
PHF	0.625	0.650	0.682	0.000	0.786	0.000	0.000	0.000	0.781	0.625	0.000	0.778	0.000	0.000	0.000	0.000	0.000	0.000	0.000	0.000	0.000	0.000	0.250	0.736	0.000	0.000	0.750	0.000	0.000	0.786
Lights	19	48	56	0	123	0	0	0	49	4	0	53	0	0	0	0	0	0	0	0	0	0	1	50	0	0	51	0	0	227
% Lights	85.0%	92.3%	93.3%	0.0%	93.2%	0.0%	0.0%	0.0%	98.0%	80.0%	0.0%	94.6%	0.0%	0.0%	0.0%	0.0%	0.0%	0.0%	0.0%	0.0%	0.0%	0.0%	100.0%	94.3%	0.0%	0.0%	94.4%	0.0%	0.0%	93.8%
Trucks	0	0	0	0	0	0	0	0	0	0	0	0	0	0	0	0	0	0	0	0	0	0	0	0	0	0	0	0	0	0
% Trucks	0.0%	0.0%	0.0%	0.0%	0.0%	0.0%	0.0%	0.0%	0.0%	0.0%	0.0%	0.0%	0.0%	0.0%	0.0%	0.0%	0.0%	0.0%	0.0%	0.0%	0.0%	0.0%	0.0%	0.0%	0.0%	0.0%	0.0%	0.0%	0.0%	0.0%
Buses	1	4	4	0	9	0	0	0	1	1	0	2	0	0	0	0	0	0	0	0	0	0	0	3	0	0	3	0	0	14
% Buses	5.0%	7.7%	6.7%	0.0%	6.8%	0.0%	0.0%	0.0%	2.0%	20.0%	0.0%	3.6%	0.0%	0.0%	0.0%	0.0%	0.0%	0.0%	0.0%	0.0%	0.0%	0.0%	0.0%	5.7%	0.0%	0.0%	6.0%	0.0%	0.0%	5.8%
Pedestrians	0	0	0	0	0	2	1	0	0	0	0	0	0	0	0	0	0	0	0	0	0	0	4	0	0	0	0	2	0	0
% Pedestrians	0.0%	0.0%	0.0%	0.0%	0.0%	100.0%	100.0%	0.0%	0.0%	0.0%	0.0%	0.0%	0.0%	0.0%	0.0%	0.0%	0.0%	0.0%	0.0%	0.0%	0.0%	0.0%	100.0%	0.0%	0.0%	0.0%	0.0%	100.0%	0.0%	0.0%
Bicycles on Crosswalk	0	0	0	0	0	0	0	0	0	0	0	0	0	0	0	0	0	0	0	0	0	0	0	0	0	0	0	0	0	0
% Bicycles on Crosswalk	0.0%	0.0%	0.0%	0.0%	0.0%	0.0%	0.0%	0.0%	0.0%	0.0%	0.0%	0.0%	0.0%	0.0%	0.0%	0.0%	0.0%	0.0%	0.0%	0.0%	0.0%	0.0%	0.0%	0.0%	0.0%	0.0%	0.0%	0.0%	0.0%	0.0%

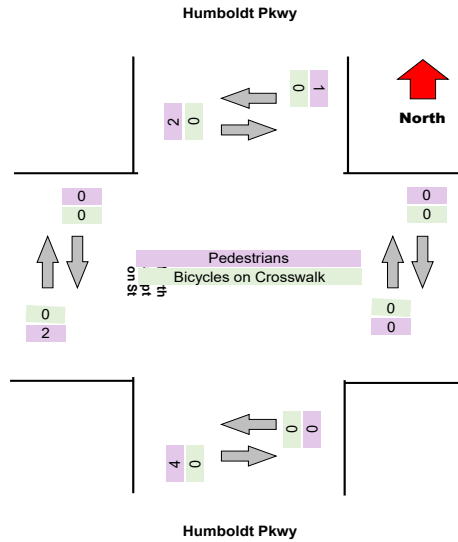
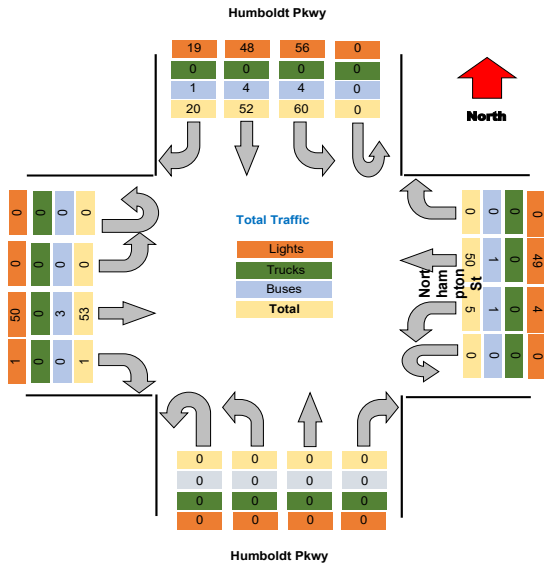

Turning Movement Peak Hour Data (PM)

4:15:00 PM

Leg Direction	Humboldt Pkwy								Northampton St								Humboldt Pkwy								Northampton St								Total
	Southbound				Northbound				Westbound				Eastbound				Northbound				Eastbound												
Start Time	Right	Thru	Left	U-Turn	App Total	Peds CW	Peds CCW		Right	Thru	Left	U-Turn	App Total	Peds CW	Peds CCW		Right	Thru	Left	U-Turn	App Total	Peds CW	Peds CCW		Right	Thru	Left	U-Turn	App Total	Peds CW	Peds CCW		
4:15:00 PM	5	22	24	0	51	0	1		0	15	3	0	18	0	0		0	0	0	0	0	0	0	0	0	0	0	0	0	0	0	0	96
4:30:00 PM	6	25	20	0	51	0	2		0	23	3	0	26	0	0		0	0	0	0	0	0	0	0	1	26	0	0	27	0	0	104	
4:45:00 PM	5	27	9	0	41	1	0		0	22	5	0	27	0	0		0	0	0	0	0	0	0	0	3	22	0	0	25	0	0	93	
5:00:00 PM	5	12	24	0	41	0	0		0	22	3	0	25	0	0		0	0	0	0	0	0	0	0	0	28	0	0	28	0	0	94	
Grand Total	21	86	77	0	154	1	3		0	82	14	0	96	0	0		0	0	0	0	0	0	0	0	4	103	0	0	107	1	2	387	
% Approach	11.4%	46.7%	41.6%	0.0%	0.0%	0.0%	0.0%		14.2%	85.8%	0.0%	0.0%	0.0%	0.0%	0.0%		45.1%	41.7%	13.2%	0.0%	0.0%	0.0%	0.0%	0.0%	0.0%	66.2%	33.8%	0.0%	0.0%	0.0%	0.0%		
% Total	5.4%	22.2%	19.9%	0.0%	47.5%	0.0%	0.0%		0.0%	21.2%	3.6%	0.0%	24.8%	0.0%	0.0%		0.0%	0.0%	0.0%	0.0%	0.0%	0.0%	0.0%	0.0%	1.0%	26.6%	0.0%	0.0%	27.6%	0.0%	0.0%		
PHF	0.875	0.796	0.802	0.000	0.902	0.000	0.000		0.000	0.891	0.700	0.000	0.889	0.000	0.000		0.000	0.000	0.000	0.000	0.000	0.000	0.000	0.000	0.333	0.920	0.000	0.000	0.955	0.000	0.000		
Lights	19	77	77	0	173	0	0		0	81	14	0	95	0	0		0	0	0	0	0	0	0	0	4	98	0	0	102	0	0	370	
% Lights	80.5%	89.5%	100.0%	0.0%	94.0%	0.0%	0.0%		0.0%	98.8%	100.0%	0.0%	99.0%	0.0%	0.0%		0.0%	0.0%	0.0%	0.0%	0.0%	0.0%	0.0%	0.0%	100.0%	95.1%	0.0%	0.0%	95.3%	0.0%	0.0%		
Trucks	0	0	0	0	0	0	0		0	0	0	0	0	0	0		0	0	0	0	0	0	0	0	0	0	0	0	0	0	0	0	
% Trucks	0.0%	0.0%	0.0%	0.0%	0.0%	0.0%	0.0%		0.0%	0.0%	0.0%	0.0%	0.0%	0.0%	0.0%		0.0%	0.0%	0.0%	0.0%	0.0%	0.0%	0.0%	0.0%	0.0%	0.0%	0.0%	0.0%	0.0%	0.0%	0.0%		
Buses	2	8	0	0	10	0	0		0	1	0	0	1	0	0		0	0	0	0	0	0	0	0	0	5	0	0	5	0	0	16	
% Buses	9.5%	9.3%	0.0%	0.0%	0.0%	0.0%	0.0%		0.0%	1.2%	0.0%	0.0%	0.0%	0.0%	0.0%		0.0%	0.0%	0.0%	0.0%	0.0%	0.0%	0.0%	0.0%	0.0%	4.9%	0.0%	0.0%	0.0%	0.0%	0.0%		
Pedestrians	0	0	0	0	0	1	3		0	0	0	0	0	0	0		0	0	0	0	0	0	0	0	0	0	0	0	0	0	0	0	
% Pedestrians	0.0%	0.0%	0.0%	0.0%	0.0%	100.0%	100.0%		0.0%	0.0%	0.0%	0.0%	0.0%	0.0%	0.0%		0.0%	0.0%	0.0%	0.0%	0.0%	0.0%	0.0%	0.0%	0.0%	0.0%	0.0%	0.0%	0.0%	0.0%	0.0%		
Bicycles on Crosswalk	0	0	0	0	0	0	0		0	0	0	0	0	0	0		0	0	0	0	0	0	0	0	0	0	0	0	0	0	0	0	
% Bicycles on Crosswalk	0.0%	0.0%	0.0%	0.0%	0.0%	0.0%	0.0%		0.0%	0.0%	0.0%	0.0%	0.0%	0.0%	0.0%		0.0%	0.0%	0.0%	0.0%	0.0%	0.0%	0.0%	0.0%	0.0%	0.0%	0.0%	0.0%	0.0%	0.0%	0.0%		

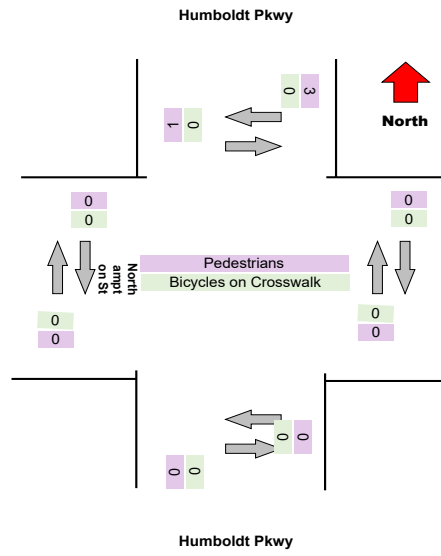
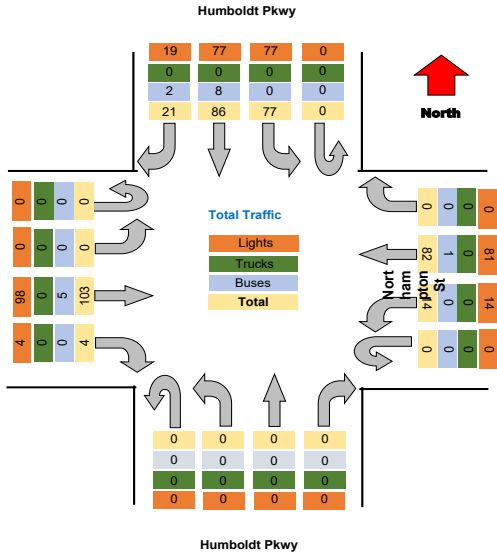

Project : VBH Malta NY
 Site : Site 4
 Location : 42.948550, -73.790036
 Survey Date : 2021-04-28, Wednesday

Turning Movement Data Plot

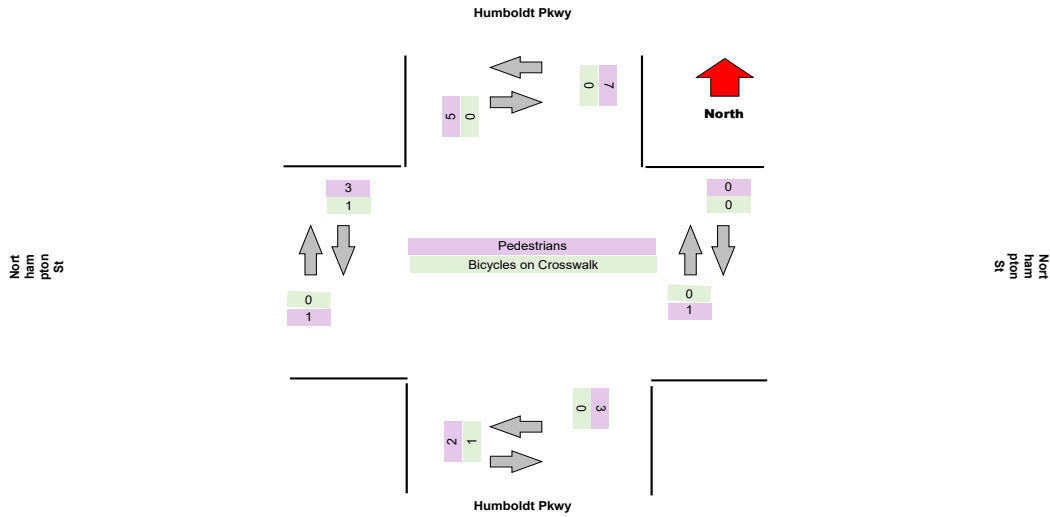
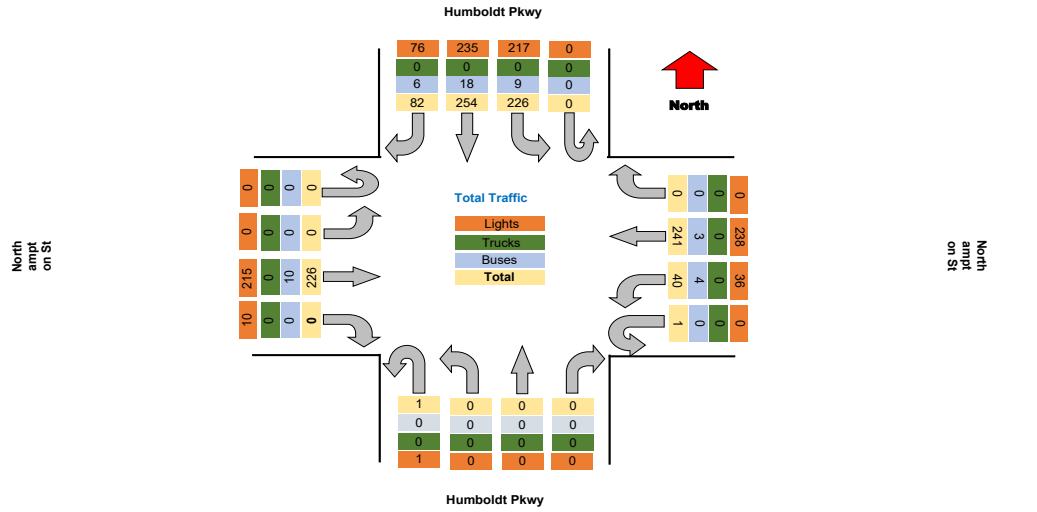

Project : VBH Malta NY
Site : Site 4
Location : 42.948550, -73.790036

TSTData.com

Survey Date : 2021-04-28, Wednesday

Turning Movement Peak Hour Data (AM)

7:30:00 AM

Leg Direction	Humboldt Pkwy								Northampton St								Humboldt Pkwy								Northampton St								Total
	Southbound				Westbound				Northbound				Eastbound				Southbound				Westbound												
Start Time	Right	Thru	Left	U-Turn	App Total	Peds CW	Peds CCW	Right	Thru	Left	U-Turn	App Total	Peds CW	Peds CCW	Right	Thru	Left	U-Turn	App Total	Peds CW	Peds CCW	Right	Thru	Left	U-Turn	App Total	Peds CW	Peds CCW					
7:30:00 AM	2	8	10	0	20	2	1	0	11	1	0	13	0	0	0	0	0	0	0	1	0	0	0	6	0	0	6	0	0	39			
7:45:00 AM	7	19	28	0	54	0	0	0	14	2	0	16	0	0	0	0	0	0	0	0	0	0	0	1	0	20	0	0	20	0	0	90	
8:00:00 AM	3	14	19	0	36	0	0	0	14	1	0	15	0	0	0	0	0	0	0	0	0	0	0	1	11	0	0	12	0	0	63		
8:15:00 AM	13	15	14	0	42	0	0	0	8	3	0	11	0	0	0	0	0	0	0	0	0	0	0	0	12	0	0	12	0	0	66		
Grand Total	25	59	71	0	152	2	1	0	47	7	0	55	0	0	0	0	0	0	0	1	1	1	1	49	0	0	50	2	0	257			
% Approach	16.4%	36.8%	46.7%	0.0%	0.0%	0.0%	0.0%	14.2%	85.8%	0.0%	0.0%	0.0%	0.0%	0.0%	45.1%	41.7%	13.2%	0.0%	0.0%	0.0%	0.0%	0.0%	0.0%	66.2%	33.8%	0.0%	0.0%	0.0%	0.0%	0.0%			
% Total	9.7%	21.8%	27.6%	0.0%	58.1%	0.0%	0.0%	0.0%	18.3%	2.7%	0.0%	21.4%	0.0%	0.0%	0.0%	0.0%	0.0%	0.0%	0.0%	0.0%	0.0%	0.0%	0.4%	19.1%	0.0%	0.0%	19.5%	0.0%	0.0%	6.8%			
PHF	0.481	0.737	0.634	0.000	0.704	0.000	0.000	0.000	0.839	0.583	0.000	0.859	0.000	0.000	0.000	0.000	0.000	0.000	0.000	0.000	0.000	0.000	0.250	0.613	0.000	0.000	0.625	0.000	0.000	0.714			
Lights	24	51	66	0	141	0	0	0	46	6	0	52	0	0	0	0	0	0	0	0	0	0	0	1	45	0	0	46	0	0	239		
% Lights	96.0%	91.1%	93.0%	0.0%	92.8%	0.0%	0.0%	0.0%	97.9%	85.7%	0.0%	94.5%	0.0%	0.0%	0.0%	0.0%	0.0%	0.0%	0.0%	0.0%	0.0%	0.0%	0.0%	100.0%	91.8%	0.0%	0.0%	92.0%	0.0%	0.0%	93.0%		
Trucks	0	0	0	0	0	0	0	0	0	0	0	0	0	0	0	0	0	0	0	0	0	0	0	0	0	0	0	0	0	0	0		
% Trucks	0.0%	0.0%	0.0%	0.0%	0.0%	0.0%	0.0%	0.0%	0.0%	0.0%	0.0%	0.0%	0.0%	0.0%	0.0%	0.0%	0.0%	0.0%	0.0%	0.0%	0.0%	0.0%	0.0%	0.0%	0.0%	0.0%	0.0%	0.0%	0.0%	0.0%	0.0%		
Buses	1	5	5	0	11	0	0	0	1	1	0	2	0	0	0	0	0	0	0	0	0	0	0	0	4	0	0	4	0	0	17		
% Buses	4.0%	8.9%	7.0%	0.0%	0.0%	0.0%	0.0%	0.0%	2.1%	14.3%	0.0%	0.0%	0.0%	0.0%	0.0%	0.0%	0.0%	0.0%	0.0%	0.0%	0.0%	0.0%	0.0%	0.0%	8.2%	0.0%	0.0%	0.0%	0.0%	0.0%	6.8%		
Pedestrians	0	0	0	0	0	2	1	0	0	0	0	0	0	0	0	0	0	0	0	1	1	0	0	0	0	0	0	0	0	0			
% Pedestrians	0.0%	0.0%	0.0%	0.0%	0.0%	100.0%	100.0%	0.0%	0.0%	0.0%	0.0%	0.0%	0.0%	0.0%	0.0%	0.0%	0.0%	0.0%	0.0%	0.0%	100.0%	100.0%	0.0%	0.0%	0.0%	0.0%	0.0%	0.0%	0.0%	0.0%	0.0%		
Bicycles on Crosswalk	0	0	0	0	0	0	0	0	0	0	0	0	0	0	0	0	0	0	0	0	0	0	0	0	0	0	0	0	0	0			
% Bicycles on Crosswalk	0.0%	0.0%	0.0%	0.0%	0.0%	0.0%	0.0%	0.0%	0.0%	0.0%	0.0%	0.0%	0.0%	0.0%	0.0%	0.0%	0.0%	0.0%	0.0%	0.0%	0.0%	0.0%	0.0%	0.0%	0.0%	0.0%	0.0%	0.0%	0.0%	0.0%			

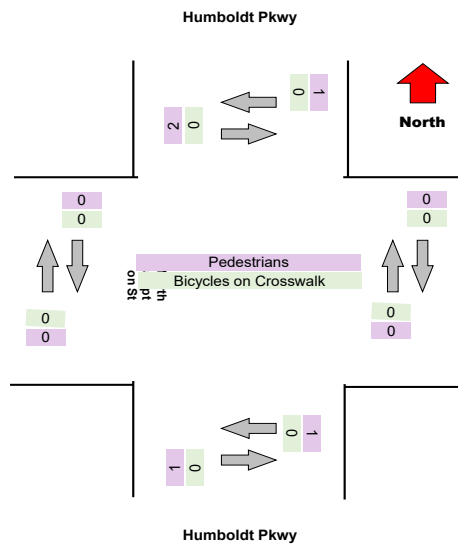
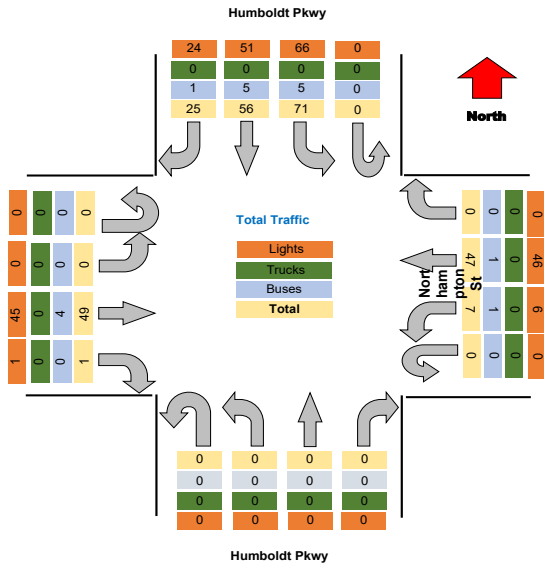

Turning Movement Peak Hour Data (PM)

4:15:00 PM

Leg Direction	Humboldt Pkwy				Northampton St				Humboldt Pkwy				Northampton St				Total										
	Southbound				Westbound				Northbound				Eastbound														
Start Time	Right	Thru	Left	U-Turn	App Total	Peds CW	Peds CCW	Right	Thru	Left	U-Turn	App Total	Peds CW	Peds CCW	Right	Thru	Left	U-Turn	App Total	Peds CW	Peds CCW	Total					
4:15:00 PM	9	22	19	0	50	0	3	0	22	5	1	28	0	0	0	0	0	0	0	0	0	31	0	0	109		
4:30:00 PM	7	29	12	0	48	0	0	0	23	3	0	26	0	0	0	0	0	0	1	0	0	1	25	0	0	100	
4:45:00 PM	4	13	16	0	33	0	1	0	20	5	0	25	0	1	0	0	0	0	0	0	0	2	6	0	0	66	
5:00:00 PM	10	19	20	0	49	0	0	0	14	3	0	17	0	0	0	0	0	0	0	0	0	1	24	0	0	91	
Grand Total	30	83	67	0	180	0	4	0	79	15	1	95	0	1	0	0	0	0	0	1	1	4	85	0	0	368	
% Approach	16.7%	46.1%	37.2%	0.0%	0.0%	0.0%	0.0%	14.2%	85.8%	0.0%	0.0%	0.0%	0.0%	0.0%	45.1%	41.7%	13.2%	0.0%	0.0%	0.0%	0.0%	0.0%	66.2%	33.8%	0.0%	0.0%	0.0%
% Total	8.2%	22.7%	18.3%	0.0%	49.2%	0.0%	0.0%	0.0%	21.6%	4.4%	0.3%	26.2%	0.0%	0.0%	0.0%	0.0%	0.0%	0.0%	0.0%	0.0%	0.0%	0.0%	1.1%	23.5%	0.0%	0.0%	24.6%
PHF	0.750	0.716	0.838	0.000	0.900	0.000	0.000	0.000	0.859	0.800	0.250	0.857	0.000	0.000	0.000	0.000	0.000	0.000	0.000	0.000	0.000	0.000	0.500	0.694	0.000	0.000	0.726
Lights	27	76	67	0	170	0	0	0	78	15	0	93	0	0	0	0	0	0	0	0	0	0	4	81	0	0	85
% Lights	80.0%	91.6%	100.0%	0.0%	94.4%	0.0%	0.0%	0.0%	98.7%	93.8%	0.0%	96.8%	0.0%	0.0%	0.0%	0.0%	0.0%	0.0%	0.0%	0.0%	0.0%	0.0%	100.0%	94.2%	0.0%	0.0%	94.4%
Trucks	0	0	0	0	0	0	0	0	0	0	0	0	0	0	0	0	0	0	0	0	0	0	0	0	0	0	0
% Trucks	0.0%	0.0%	0.0%	0.0%	0.0%	0.0%	0.0%	0.0%	0.0%	0.0%	0.0%	0.0%	0.0%	0.0%	0.0%	0.0%	0.0%	0.0%	0.0%	0.0%	0.0%	0.0%	0.0%	0.0%	0.0%	0.0%	0.0%
Buses	3	6	0	0	9	0	0	0	1	1	0	2	0	0	0	0	0	0	0	0	0	0	0	4	0	0	4
% Buses	10.0%	7.2%	0.0%	0.0%	0.0%	0.0%	0.0%	0.0%	1.3%	6.3%	0.0%	0.0%	0.0%	0.0%	0.0%	0.0%	0.0%	0.0%	0.0%	0.0%	0.0%	0.0%	0.0%	4.7%	0.0%	0.0%	0.0%
Pedestrians	0	0	0	0	0	0	4	0	0	0	0	0	1	0	0	0	0	0	0	0	0	0	0	0	0	1	1
% Pedestrians	0.0%	0.0%	0.0%	0.0%	0.0%	0.0%	100.0%	0.0%	0.0%	0.0%	0.0%	0.0%	0.0%	0.0%	0.0%	100.0%	0.0%	0.0%	0.0%	0.0%	0.0%	0.0%	0.0%	0.0%	0.0%	0.0%	100.0%
Bicycles on Crosswalk	0	0	0	0	0	0	0	0	0	0	0	0	0	0	0	0	0	0	0	0	0	1	0	0	0	0	1
% Bicycles on Crosswalk	0.0%	0.0%	0.0%	0.0%	0.0%	0.0%	0.0%	0.0%	0.0%	0.0%	0.0%	0.0%	0.0%	0.0%	0.0%	0.0%	0.0%	0.0%	0.0%	0.0%	0.0%	100.0%	0.0%	0.0%	0.0%	0.0%	50.0%

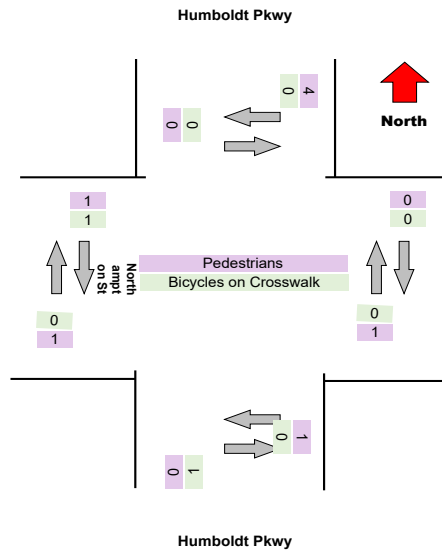
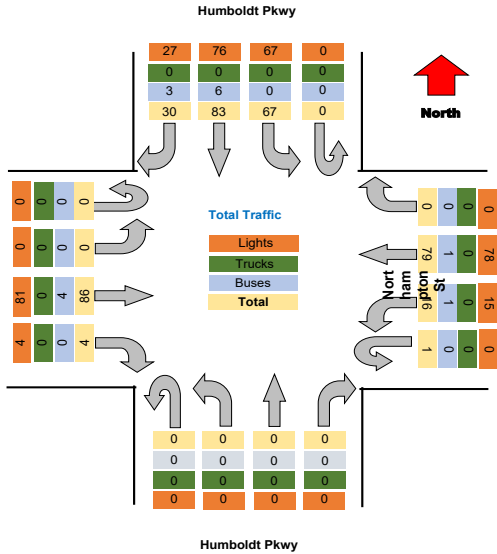

Project : VBH Malta NY
 Site : Site 4
 Location : 42.948550, -73.790036
 Survey Date : 2021-04-28, Wednesday

Turning Movement Data Plot

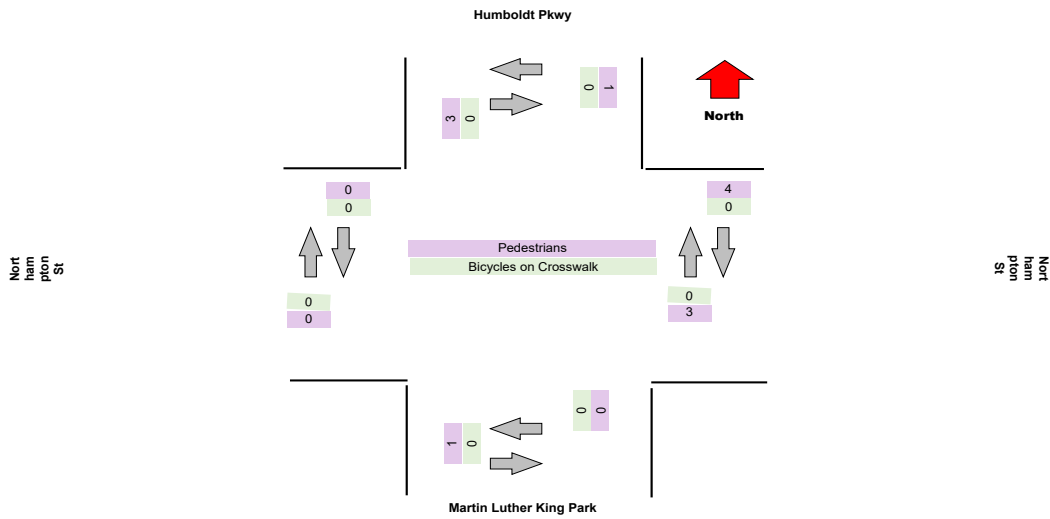
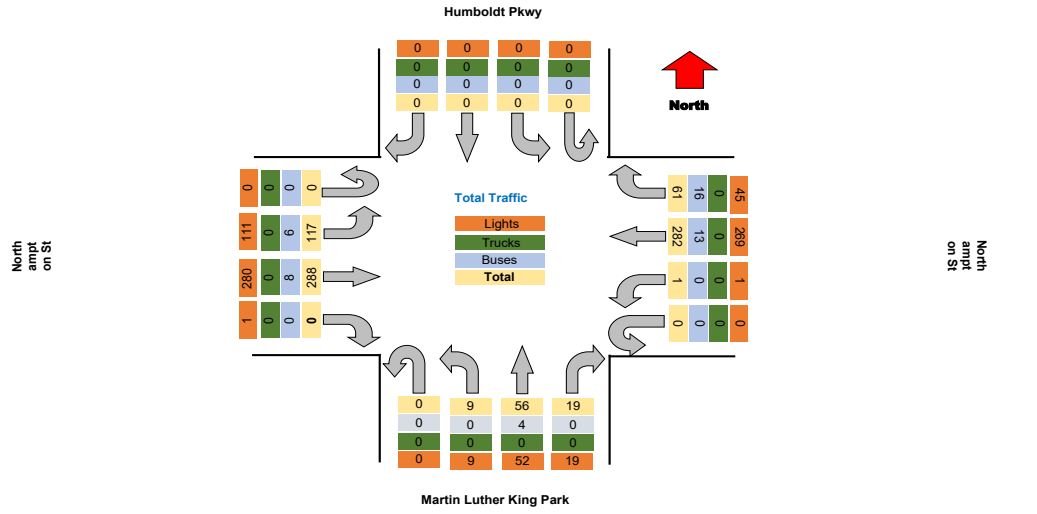

Project : VBH Malta NY
Site : Site 4
Location : 42.948550, -73.790036

TSTData.com

Survey Date : 2021-04-28, Wednesday

Turning Movement Peak Hour Data (PM)

4:15:00 PM

Leg Direction	Humboldt Pkwy										Northampton St										Martin Luther King Park										Northampton St										Total
	Southbound					Westbound					Northbound					Eastbound					Northbound					Eastbound															
Start Time	Right	Thru	Left	U-Turn	App Total	Peds CW	Peds CCW	Right	Thru	Left	U-Turn	App Total	Peds CW	Peds CCW	Right	Thru	Left	U-Turn	App Total	Peds CW	Peds CCW	Right	Thru	Left	U-Turn	App Total	Peds CW	Peds CCW	Right	Thru	Left	U-Turn	App Total	Peds CW	Peds CCW						
4:15:00 PM	0	0	0	0	0	0	0	9	16	0	0	25	0	0	4	7	0	0	11	0	0	0	33	12	0	45	0	0	0	0	0	0	0	0	0	81					
4:30:00 PM	0	0	0	0	0	0	0	8	22	0	0	30	0	0	0	6	0	0	6	0	0	0	28	9	0	37	0	0	0	0	0	0	0	0	0	73					
4:45:00 PM	0	0	0	0	0	0	0	3	20	0	0	23	1	1	0	5	0	0	5	0	0	0	26	14	0	40	0	0	0	0	0	0	0	0	0	68					
5:00:00 PM	0	0	0	0	0	0	0	4	24	0	0	28	2	0	1	1	1	0	3	0	0	0	19	13	0	32	0	0	0	0	0	0	0	0	0	63					
Grand Total	0	0	0	0	0	0	0	24	62	0	0	106	3	1	5	19	1	0	25	3	1	0	106	48	0	154	3	0	0	0	0	0	0	0	0	285					
% Approach	#DIV/0!	#DIV/0!	#DIV/0!	#DIV/0!	0.0%	0.0%	0.0%	14.2%	85.8%	0.0%	0.0%	0.0%	0.0%	0.0%	45.1%	41.7%	13.2%	0.0%	0.0%	0.0%	0.0%	0.0%	66.2%	33.8%	0.0%	0.0%	0.0%	0.0%	0.0%	0.0%	0.0%	0.0%	0.0%	0.0%	0.0%						
% Total	0.0%	0.0%	0.0%	0.0%	0.0%	0.0%	0.0%	8.4%	28.8%	0.0%	0.0%	37.2%	0.0%	0.0%	1.8%	6.7%	0.4%	0.0%	8.8%	0.0%	0.0%	0.0%	37.2%	16.8%	0.0%	54.0%	0.0%	0.0%	0.0%	0.0%	0.0%	0.0%	0.0%	0.0%	0.0%						
PHF	0.000	0.000	0.000	0.000	0.000	0.000	0.000	0.667	0.854	0.000	0.000	0.883	0.000	0.000	0.313	0.679	0.250	0.000	0.566	0.000	0.000	0.000	0.803	0.857	0.000	0.856	0.000	0.000	0.000	0.000	0.000	0.000	0.000	0.000	0.000						
Lights	0	0	0	0	0	0	0	17	81	0	0	98	0	0	5	16	1	0	22	0	0	0	102	46	0	148	0	0	0	0	0	0	0	0	0	268					
% Lights	0.0%	0.0%	0.0%	0.0%	0.0%	0.0%	0.0%	70.8%	98.8%	0.0%	0.0%	92.5%	0.0%	0.0%	100.0%	84.2%	100.0%	0.0%	88.0%	0.0%	0.0%	0.0%	96.2%	95.8%	0.0%	96.1%	0.0%	0.0%	0.0%	0.0%	0.0%	0.0%	0.0%	0.0%	0.0%						
Trucks	0	0	0	0	0	0	0	0	0	0	0	0	0	0	0	0	0	0	0	0	0	0	0	0	0	0	0	0	0	0	0	0	0	0	0	0					
% Trucks	0.0%	0.0%	0.0%	0.0%	0.0%	0.0%	0.0%	0.0%	0.0%	0.0%	0.0%	0.0%	0.0%	0.0%	0.0%	0.0%	0.0%	0.0%	0.0%	0.0%	0.0%	0.0%	0.0%	0.0%	0.0%	0.0%	0.0%	0.0%	0.0%	0.0%	0.0%	0.0%	0.0%	0.0%	0.0%						
Buses	0	0	0	0	0	0	0	7	1	0	0	8	0	0	0	3	0	0	3	0	0	0	4	2	0	6	0	0	0	0	0	0	0	0	0	17					
% Buses	0.0%	0.0%	0.0%	0.0%	0.0%	0.0%	0.0%	29.2%	1.2%	0.0%	0.0%	0.0%	0.0%	0.0%	0.0%	15.8%	0.0%	0.0%	0.0%	0.0%	0.0%	0.0%	3.8%	4.2%	0.0%	0.0%	0.0%	0.0%	0.0%	0.0%	0.0%	0.0%	0.0%	0.0%	0.0%						
Pedestrians	0	0	0	0	0	0	0	0	0	0	0	3	1	1	0	0	0	0	0	1	0	0	0	0	0	0	0	0	0	0	0	0	0	0	0	0					
% Pedestrians	0.0%	0.0%	0.0%	0.0%	0.0%	0.0%	0.0%	0.0%	0.0%	0.0%	0.0%	100.0%	100.0%	100.0%	0.0%	0.0%	0.0%	0.0%	0.0%	0.0%	0.0%	0.0%	0.0%	0.0%	0.0%	0.0%	0.0%	0.0%	0.0%	0.0%	0.0%	0.0%	0.0%	0.0%	0.0%						
Bicycles on Crosswalk	0	0	0	0	0	0	0	0	0	0	0	0	0	0	0	0	0	0	0	0	0	0	0	0	0	0	0	0	0	0	0	0	0	0	0	0					
% Bicycles on Crosswalk	0.0%	0.0%	0.0%	0.0%	0.0%	0.0%	0.0%	0.0%	0.0%	0.0%	0.0%	0.0%	0.0%	0.0%	0.0%	0.0%	0.0%	0.0%	0.0%	0.0%	0.0%	0.0%	0.0%	0.0%	0.0%	0.0%	0.0%	0.0%	0.0%	0.0%	0.0%	0.0%	0.0%	0.0%	0.0%						

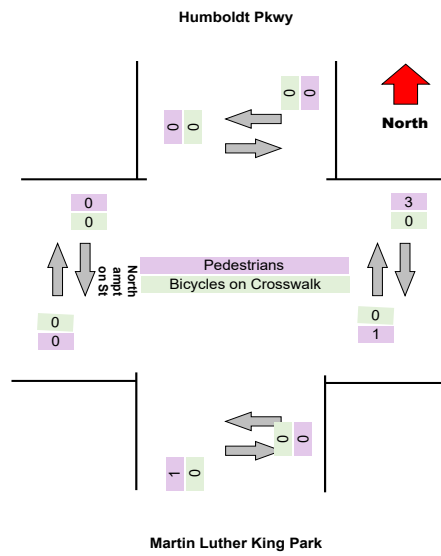
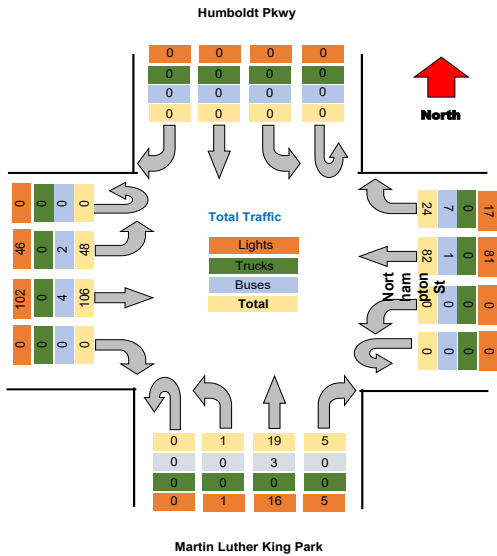

Project : VBH Malta NY
 Site : Site 4
 Location : 42.948550, -73.790036
 Survey Date : 2021-04-28, Wednesday

Turning Movement Data Plot

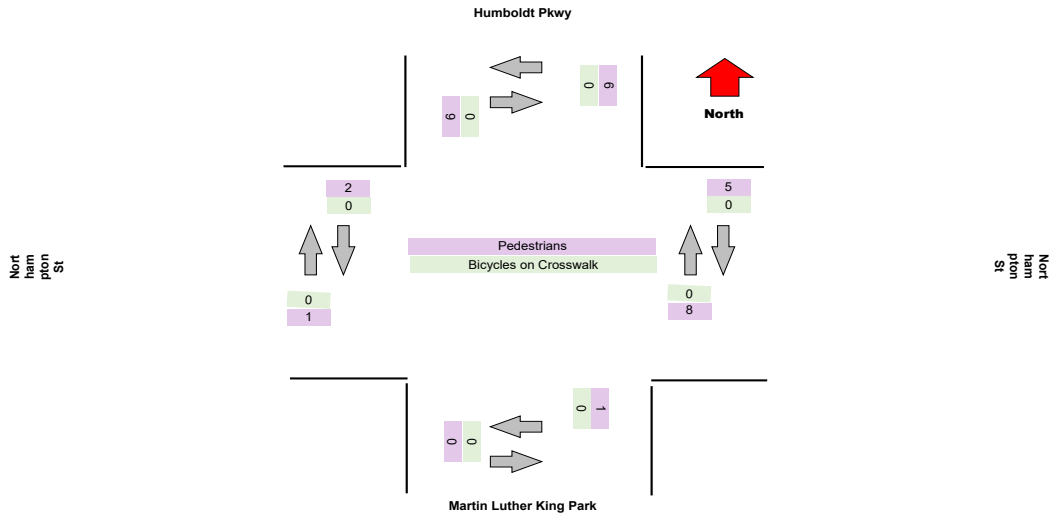
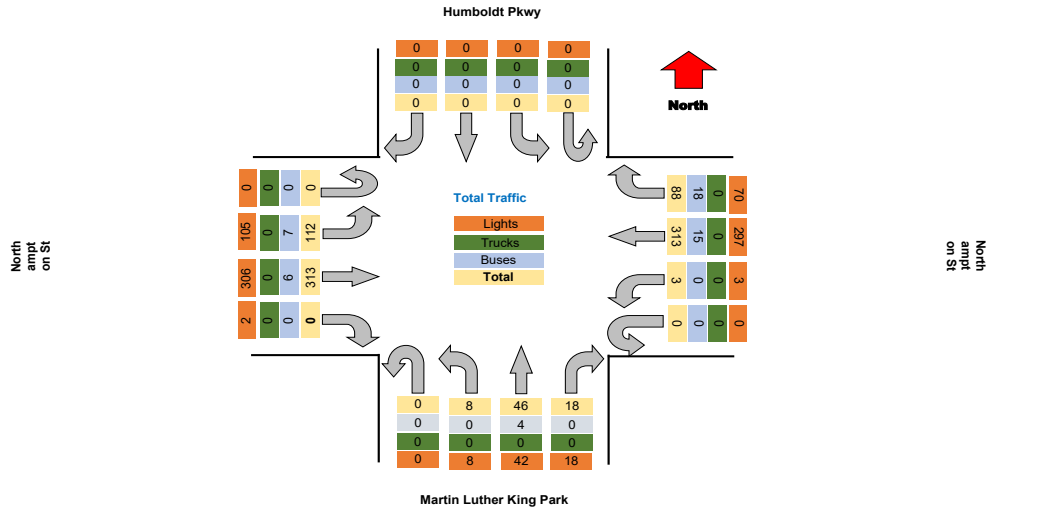

Project : VBH Malta NY
Site : Site 4
Location : 42.948550, -73.790036

TSTData.com

Survey Date : 2021-04-28, Wednesday

Turning Movement Peak Hour Data (AM)

7:30:00 AM

Leg Direction	Humboldt Pkwy								Northampton St								Martin Luther King Park								Northampton St								Total
	Southbound				Northbound				Westbound				Eastbound				Northbound				Eastbound												
Start Time	Right	Thru	Left	U-Turn	App Total	Peds CW	Peds CCW		Right	Thru	Left	U-Turn	App Total	Peds CW	Peds CCW		Right	Thru	Left	U-Turn	App Total	Peds CW	Peds CCW		Right	Thru	Left	U-Turn	App Total	Peds CW	Peds CCW		
7:30:00 AM	0	0	0	0	0	2	0		5	15	1	0	21	0	0		0	5	0	0	5	0	0		0	7	3	0	10	0	0		36
7:45:00 AM	0	0	0	0	0	0	0		4	29	0	0	33	0	0		4	5	0	0	9	0	0		0	18	8	0	26	0	0		68
8:00:00 AM	0	0	0	0	0	0	0		4	21	0	0	25	0	0		0	6	3	0	9	0	0		0	15	8	0	23	0	0		57
8:15:00 AM	0	0	0	0	0	0	0		7	5	0	0	12	0	0		3	2	2	0	7	0	0		0	25	1	0	26	0	0		50
Grand Total	0	0	0	0	0	2	0		29	73	1	0	95	0	0		7	19	5	0	31	0	0		0	65	20	0	85	0	0		211
% Approach	#DIV/0!	#DIV/0!	#DIV/0!	#DIV/0!	0.0%	0.0%	0.0%		14.2%	85.8%	0.0%	0.0%	0.0%	0.0%	0.0%		45.1%	41.7%	13.2%	0.0%	0.0%	0.0%	0.0%		0.0%	66.2%	33.8%	0.0%	0.0%	0.0%	0.0%		
% Total	0.0%	0.0%	0.0%	0.0%	0.0%	0.0%	0.0%		9.5%	34.6%	0.5%	0.0%	45.0%	0.0%	0.0%		3.3%	8.5%	2.4%	0.0%	14.7%	0.0%	0.0%		0.0%	30.8%	9.5%	0.0%	40.3%	0.0%	0.0%		
PHF	0.000	0.000	0.000	0.000	0.000	0.000	0.000		0.714	0.629	0.250	0.000	0.720	0.000	0.000		0.438	0.750	0.417	0.000	0.861	0.000	0.000		0.000	0.650	0.625	0.000	0.817	0.000	0.000		0.776
Lights	0	0	0	0	0	0	0		13	64	1	0	78	0	0		7	17	5	0	29	0	0		0	63	19	0	82	0	0		189
% Lights	0.0%	0.0%	0.0%	0.0%	0.0%	0.0%	0.0%		85.0%	87.7%	100.0%	0.0%	82.1%	0.0%	0.0%		100.0%	94.4%	100.0%	0.0%	93.5%	0.0%	0.0%		0.0%	96.9%	95.0%	0.0%	96.5%	0.0%	0.0%		89.6%
Trucks	0	0	0	0	0	0	0		0	0	0	0	0	0	0		0	0	0	0	0	0	0		0	0	0	0	0	0	0		0
% Trucks	0.0%	0.0%	0.0%	0.0%	0.0%	0.0%	0.0%		0.0%	0.0%	0.0%	0.0%	0.0%	0.0%	0.0%		0.0%	0.0%	0.0%	0.0%	0.0%	0.0%	0.0%		0.0%	0.0%	0.0%	0.0%	0.0%	0.0%	0.0%		0.0%
Buses	0	0	0	0	0	0	0		7	9	0	0	16	0	0		0	1	0	0	1	0	0		0	2	1	0	3	0	0		20
% Buses	0.0%	0.0%	0.0%	0.0%	0.0%	0.0%	0.0%		35.0%	12.3%	0.0%	0.0%	0.0%	0.0%	0.0%		0.0%	5.8%	0.0%	0.0%	0.0%	0.0%	0.0%		0.0%	3.1%	5.0%	0.0%	0.0%	0.0%	0.0%		9.5%
Pedestrians	0	0	0	0	2	1	0		0	0	0	0	0	0	0		0	0	0	0	0	0	0		0	0	0	0	0	0	0		0
% Pedestrians	0.0%	0.0%	0.0%	0.0%	100.0%	100.0%	0.0%		0.0%	0.0%	0.0%	0.0%	0.0%	0.0%	0.0%		0.0%	0.0%	0.0%	0.0%	0.0%	0.0%	0.0%		0.0%	0.0%	0.0%	0.0%	0.0%	0.0%	0.0%		0.0%
Bicycles on Crosswalk	0	0	0	0	0	0	0		0	0	0	0	0	0	0		0	0	0	0	0	0	0		0	0	0	0	0	0	0		0
% Bicycles on Crosswalk	0.0%	0.0%	0.0%	0.0%	0.0%	0.0%	0.0%		0.0%	0.0%	0.0%	0.0%	0.0%	0.0%	0.0%		0.0%	0.0%	0.0%	0.0%	0.0%	0.0%	0.0%		0.0%	0.0%	0.0%	0.0%	0.0%	0.0%	0.0%		0.0%

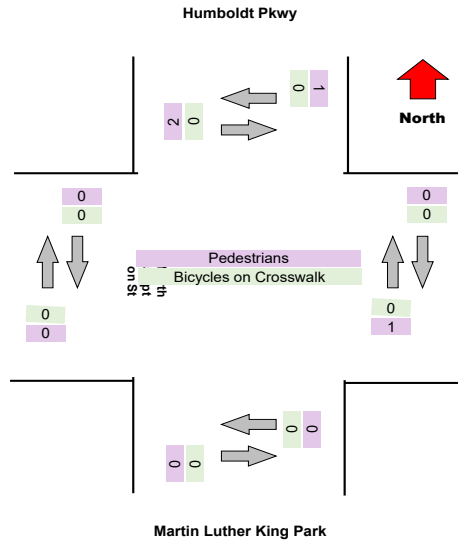
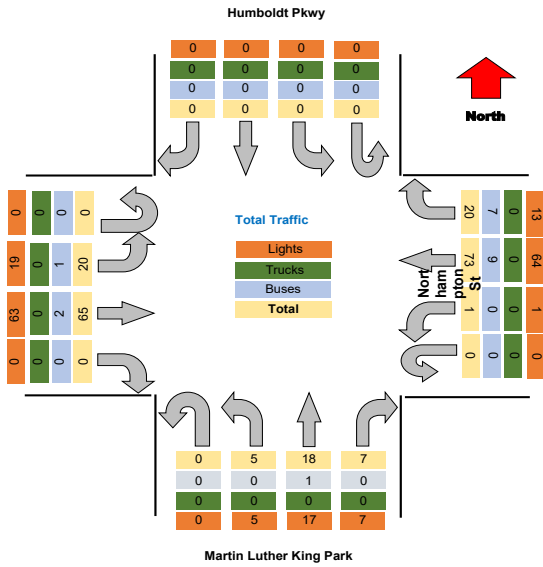

Project : VBH Malta NY
Site : Site 4
Location : 42.948550, -73.790036

TSTData.com

Survey Date : 2021-04-28, Wednesday

Turning Movement Peak Hour Data (PM)

4:15:00 PM

Leg Direction	Humboldt Pkwy										Northampton St										Martin Luther King Park										Northampton St										Total
	Southbound					Westbound					Northbound					Eastbound					Northbound					Eastbound															
	Right	Thru	Left	U-Turn	App Total	Right	Thru	Left	U-Turn	App Total	Right	Thru	Left	U-Turn	App Total	Right	Thru	Left	U-Turn	App Total	Right	Thru	Left	U-Turn	App Total	Right	Thru	Left	U-Turn	App Total											
4:15:00 PM	0	0	0	0	0	11	20	0	0	31	0	7	0	0	7	0	0	0	0	0	0	37	12	0	49	0	0	0	0	0	87										
4:30:00 PM	0	0	0	0	0	4	28	0	0	32	1	1	1	1	4	2	0	0	0	2	0	0	0	0	0	1	29	13	0	43	77										
4:45:00 PM	0	0	0	0	0	11	25	1	0	37	0	0	0	0	0	1	3	1	0	5	0	0	0	0	0	0	21	7	0	28	70										
5:00:00 PM	0	0	0	0	0	7	24	0	0	31	0	2	2	2	6	2	1	1	0	4	0	0	0	0	0	0	38	11	0	49	84										
Grand Total	0	0	0	0	0	33	97	1	0	131	1	9	3	3	16	5	11	2	0	18	0	1	125	43	0	189	3	2	0	194	318										
% Approach	#DIV/0!	#DIV/0!	#DIV/0!	#DIV/0!	0.0%	14.2%	85.8%	0.0%	0.0%	0.0%	45.1%	41.7%	13.2%	0.0%	0.0%	0.0%	66.2%	33.8%	0.0%	0.0%	0.0%	66.2%	33.8%	0.0%	0.0%	0.0%	0.0%	0.0%	0.0%	0.0%											
% Total	0.0%	0.0%	0.0%	0.0%	0.0%	10.4%	30.5%	0.3%	0.0%	41.2%	1.6%	3.5%	0.6%	0.0%	5.7%	0.3%	39.3%	13.5%	0.0%	5.3%	0.3%	39.3%	13.5%	0.0%	5.3%	0.0%	0.0%	0.0%	0.0%	0.0%											
PHF	0.000	0.000	0.000	0.000	0.000	0.750	0.866	0.250	0.000	0.885	0.625	0.393	0.500	0.000	0.643	0.250	0.822	0.827	0.000	0.862	0.250	0.822	0.827	0.000	0.862	0.000	0.000	0.000	0.000	0.000											
Lights	0	0	0	0	0	27	96	1	0	124	0	0	0	0	0	5	8	2	0	15	0	1	123	39	0	163	0	0	0	0											
% Lights	0.0%	0.0%	0.0%	0.0%	0.0%	81.8%	99.0%	100.0%	0.0%	94.7%	100.0%	72.7%	100.0%	0.0%	83.3%	100.0%	98.4%	90.7%	0.0%	96.4%	100.0%	98.4%	90.7%	0.0%	96.4%	0.0%	0.0%	0.0%	0.0%	0.0%											
Trucks	0	0	0	0	0	0	0	0	0	0	0	0	0	0	0	0	0	0	0	0	0	0	0	0	0	0	0	0	0	0											
% Trucks	0.0%	0.0%	0.0%	0.0%	0.0%	0.0%	0.0%	0.0%	0.0%	0.0%	0.0%	0.0%	0.0%	0.0%	0.0%	0.0%	0.0%	0.0%	0.0%	0.0%	0.0%	0.0%	0.0%	0.0%	0.0%	0.0%	0.0%	0.0%	0.0%	0.0%											
Buses	0	0	0	0	0	6	1	0	0	7	0	0	0	0	0	3	0	0	0	3	0	2	4	0	6	0	0	0	0	0											
% Buses	0.0%	0.0%	0.0%	0.0%	0.0%	18.2%	1.0%	0.0%	0.0%	5.3%	0.0%	0.0%	0.0%	0.0%	0.0%	100.0%	27.3%	0.0%	0.0%	16.7%	0.0%	1.8%	9.3%	0.0%	10.0%	0.0%	0.0%	0.0%	0.0%	0.0%											
Pedestrians	0	0	0	0	3	0	0	0	0	0	1	3	0	0	4	0	0	0	0	0	0	0	0	0	0	0	0	0	0	0											
% Pedestrians	0.0%	0.0%	0.0%	0.0%	100.0%	0.0%	0.0%	0.0%	0.0%	0.0%	100.0%	100.0%	0.0%	0.0%	0.0%	0.0%	0.0%	0.0%	0.0%	0.0%	0.0%	0.0%	0.0%	0.0%	0.0%	0.0%	0.0%	100.0%	0.0%	0.0%											
Bicycles on Crosswalk	0	0	0	0	0	0	0	0	0	0	0	0	0	0	0	0	0	0	0	0	0	0	0	0	0	0	0	0	0	0											
% Bicycles on Crosswalk	0.0%	0.0%	0.0%	0.0%	0.0%	0.0%	0.0%	0.0%	0.0%	0.0%	0.0%	0.0%	0.0%	0.0%	0.0%	0.0%	0.0%	0.0%	0.0%	0.0%	0.0%	0.0%	0.0%	0.0%	0.0%	0.0%	0.0%	0.0%	0.0%	0.0%											

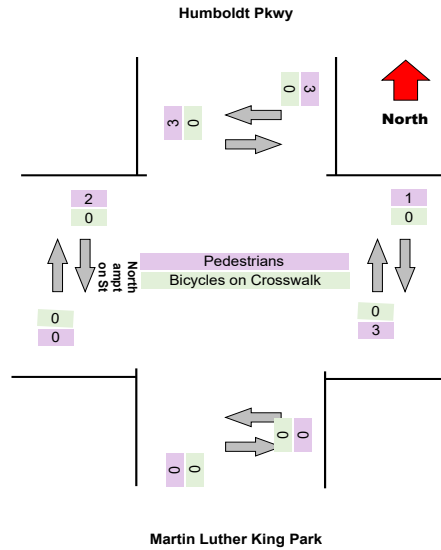
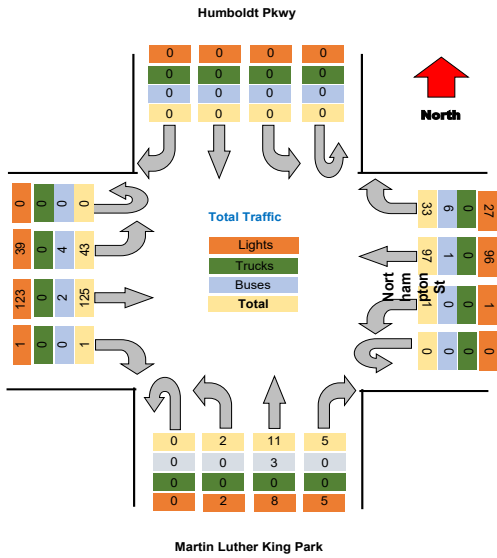

Turning Movement Data Plot

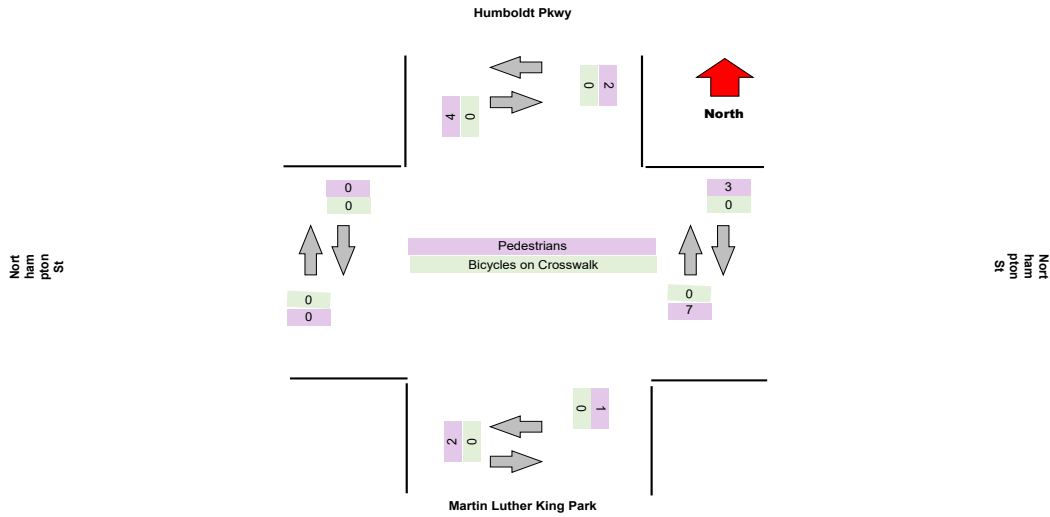
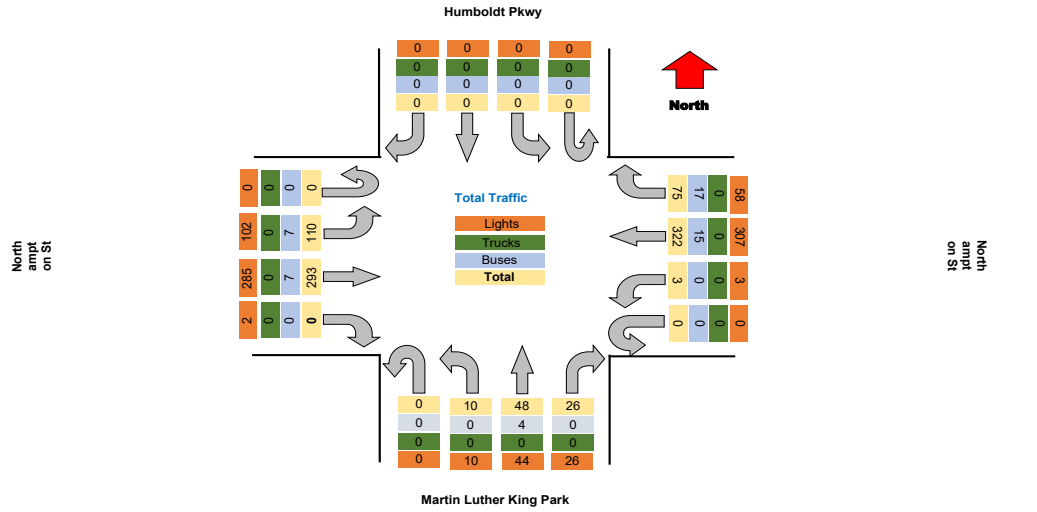

Project : VBH Malta NY
Site : Site 4
Location : 42.948550, -73.790036

TSTData.com

Survey Date : 2021-04-28, Wednesday

Turning Movement Peak Hour Data (AM)

7:30:00 AM

Leg Direction	Humboldt Pkwy										Northampton St										Martin Luther King Park										Northampton St										Total
	Southbound					Westbound					Northbound					Eastbound																									
Start Time	Right	Thru	Left	U-Turn	App Total	Peds CW	Peds CCW	Right	Thru	Left	U-Turn	App Total	Peds CW	Peds CCW	Right	Thru	Left	U-Turn	App Total	Peds CW	Peds CCW	Right	Thru	Left	U-Turn	App Total	Peds CW	Peds CCW													
7:30:00 AM	0	0	0	0	0	0	2	1	2	19	0	0	22	0	0	0	0	0	2	0	0	0	0	2	0	6	3	0	9	0	0	0									
7:45:00 AM	0	0	0	0	0	0	0	0	5	24	0	0	29	0	0	0	0	0	2	3	1	0	0	6	0	0	0	0	0	0	29	11	0	40	0	0	0				
8:00:00 AM	0	0	0	0	0	0	0	0	10	23	1	0	34	0	0	0	0	0	1	9	2	0	0	12	0	0	0	0	0	0	15	9	0	24	0	0	0				
8:15:00 AM	0	0	0	0	0	0	0	0	3	14	0	0	17	0	0	0	0	0	3	2	0	0	0	7	0	0	0	0	0	0	14	3	0	17	0	0	0				
Grand Total	0	0	0	0	0	0	2	1	20	80	1	0	102	0	0	0	0	0	6	16	3	0	0	27	0	0	0	0	0	0	64	26	0	90	0	0	0				
% Approach	#DIV/0!	#DIV/0!	#DIV/0!	#DIV/0!	0.0%	0.0%	0.0%	14.2%	85.8%	0.0%	0.0%	0.0%	0.0%	0.0%	45.1%	41.7%	13.2%	0.0%	0.0%	0.0%	0.0%	0.0%	66.2%	33.8%	0.0%	0.0%	0.0%	0.0%	0.0%												
% Total	0.0%	0.0%	0.0%	0.0%	0.0%	0.0%	0.0%	9.1%	36.5%	0.5%	0.0%	46.6%	0.0%	0.0%	2.7%	7.3%	1.4%	0.0%	12.3%	0.0%	0.0%	0.0%	29.2%	11.9%	0.0%	41.1%	0.0%	0.0%	0.0%												
PHF	0.000	0.000	0.000	0.000	0.000	0.000	0.000	0.500	0.833	0.250	0.000	0.750	0.000	0.000	0.500	0.444	0.375	0.000	0.563	0.000	0.000	0.000	0.552	0.591	0.000	0.563	0.000	0.000	0.000												
Lights	0	0	0	0	0	0	0	13	70	1	0	84	0	0	6	15	3	0	24	0	0	0	62	24	0	86	0	0	0												
% Lights	0.0%	0.0%	0.0%	0.0%	0.0%	0.0%	0.0%	85.0%	87.5%	100.0%	0.0%	82.4%	0.0%	0.0%	100.0%	93.8%	100.0%	0.0%	88.9%	0.0%	0.0%	0.0%	96.9%	92.3%	0.0%	95.6%	0.0%	0.0%	0.0%												
Trucks	0	0	0	0	0	0	0	0	0	0	0	0	0	0	0	0	0	0	0	0	0	0	0	0	0	0	0	0	0												
% Trucks	0.0%	0.0%	0.0%	0.0%	0.0%	0.0%	0.0%	0.0%	0.0%	0.0%	0.0%	0.0%	0.0%	0.0%	0.0%	0.0%	0.0%	0.0%	0.0%	0.0%	0.0%	0.0%	0.0%	0.0%	0.0%	0.0%	0.0%	0.0%	0.0%												
Buses	0	0	0	0	0	0	0	7	10	0	0	17	0	0	1	0	0	0	1	0	0	0	2	2	0	4	0	0	0												
% Buses	0.0%	0.0%	0.0%	0.0%	0.0%	0.0%	0.0%	35.0%	12.5%	0.0%	0.0%	0.0%	0.0%	0.0%	0.0%	6.3%	0.0%	0.0%	0.0%	0.0%	0.0%	0.0%	3.1%	7.7%	0.0%	0.0%	0.0%	0.0%	0.0%												
Pedestrians	0	0	0	0	0	2	1	0	0	0	0	0	2	0	0	0	0	0	0	0	0	0	0	0	0	0	0	0	0												
% Pedestrians	0.0%	0.0%	0.0%	0.0%	0.0%	100.0%	100.0%	0.0%	0.0%	0.0%	0.0%	0.0%	100.0%	0.0%	0.0%	0.0%	0.0%	0.0%	0.0%	0.0%	0.0%	0.0%	0.0%	0.0%	0.0%	0.0%	0.0%	0.0%	0.0%												
Bicycles on Crosswalk	0	0	0	0	0	0	0	0	0	0	0	0	0	0	0	0	0	0	0	0	0	0	0	0	0	0	0	0	0												
% Bicycles on Crosswalk	0.0%	0.0%	0.0%	0.0%	0.0%	0.0%	0.0%	0.0%	0.0%	0.0%	0.0%	0.0%	0.0%	0.0%	0.0%	0.0%	0.0%	0.0%	0.0%	0.0%	0.0%	0.0%	0.0%	0.0%	0.0%	0.0%	0.0%	0.0%	0.0%												

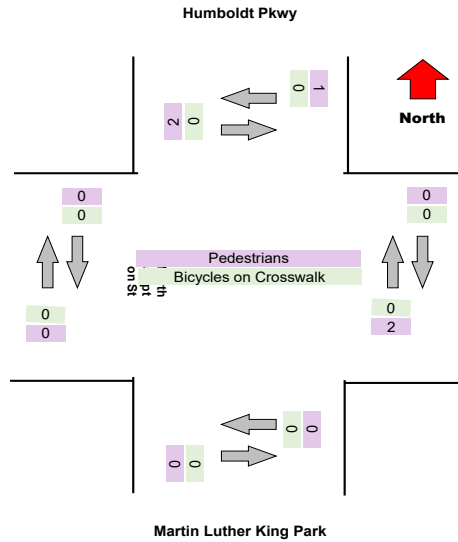
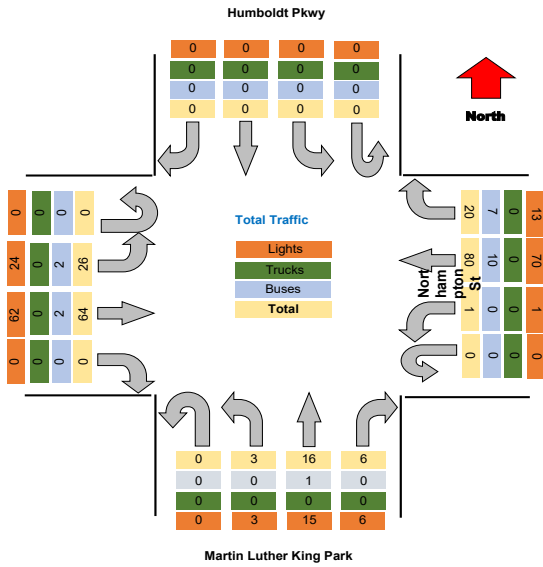

Turning Movement Peak Hour Data (PM)

4:15:00 PM

Leg Direction	Humboldt Pkwy										Northampton St										Total													
	Southbound					Westbound					Northbound					Eastbound																		
	Right	Thru	Left	U-Turn	App Total	Peds CW	Peds CCW	Right	Thru	Left	U-Turn	App Total	Peds CW	Peds CCW	Right	Thru	Left	U-Turn	App Total	Peds CW		Peds CCW												
4:15:00 PM	0	0	0	0	0	0	0	0	0	0	6	27	0	0	33	0	0	0	0	0	3	2	1	0	6	0	0	33	13	0	46	0	0	85
4:30:00 PM	0	0	0	0	0	0	0	0	0	0	9	28	0	0	37	0	0	0	0	0	1	2	0	0	3	1	0	21	16	0	37	0	0	77
4:45:00 PM	0	0	0	0	0	0	0	0	0	0	7	28	0	0	35	0	0	0	0	0	1	3	1	0	5	0	0	15	6	0	21	0	0	61
5:00:00 PM	0	0	0	0	0	0	0	0	0	0	3	21	0	0	24	0	0	0	0	0	2	8	0	0	10	0	0	33	7	0	40	0	0	74
Grand Total	0	0	0	0	0	0	0	0	0	0	25	104	0	0	129	0	0	0	0	0	7	15	2	0	24	1	0	102	42	0	144	0	0	297
% Approach	#DIV/0!	#DIV/0!	#DIV/0!	#DIV/0!	0.0%	0.0%	0.0%	0.0%	0.0%	0.0%	14.2%	85.8%	0.0%	0.0%	0.0%	0.0%	0.0%	0.0%	0.0%	0.0%	45.1%	41.7%	13.2%	0.0%	0.0%	0.0%	66.2%	33.8%	0.0%	0.0%	0.0%	0.0%	0.0%	
% Total	0.0%	0.0%	0.0%	0.0%	0.0%	0.0%	0.0%	0.0%	0.0%	0.0%	8.4%	35.0%	0.0%	0.0%	43.4%	0.0%	0.0%	0.0%	0.0%	0.0%	2.4%	5.1%	0.7%	0.0%	8.1%	0.0%	34.3%	14.1%	0.0%	48.5%	0.0%	0.0%	0.0%	
PHF	0.000	0.000	0.000	0.000	0.000	0.000	0.000	0.000	0.000	0.000	0.694	0.929	0.000	0.000	0.872	0.000	0.000	0.000	0.000	0.000	0.583	0.469	0.500	0.000	0.600	0.000	0.773	0.656	0.000	0.783	0.000	0.000	0.000	
Lights	0	0	0	0	0	0	0	0	0	0	20	102	0	0	122	0	0	0	0	0	7	13	2	0	22	0	0	100	38	0	138	0	0	282
% Lights	0.0%	0.0%	0.0%	0.0%	0.0%	0.0%	0.0%	0.0%	0.0%	0.0%	80.0%	98.1%	0.0%	0.0%	94.6%	0.0%	0.0%	0.0%	0.0%	0.0%	100.0%	86.7%	100.0%	0.0%	91.7%	0.0%	0.0%	0.0%	98.0%	90.5%	95.8%	0.0%	0.0%	94.9%
Trucks	0	0	0	0	0	0	0	0	0	0	0	0	0	0	0	0	0	0	0	0	0	0	0	0	0	0	0	0	0	0	0	0	0	0
% Trucks	0.0%	0.0%	0.0%	0.0%	0.0%	0.0%	0.0%	0.0%	0.0%	0.0%	0.0%	0.0%	0.0%	0.0%	0.0%	0.0%	0.0%	0.0%	0.0%	0.0%	0.0%	0.0%	0.0%	0.0%	0.0%	0.0%	0.0%	0.0%	0.0%	0.0%	0.0%	0.0%	0.0%	0.0%
Buses	0	0	0	0	0	0	0	0	0	0	5	2	0	0	7	0	0	0	0	0	0	2	0	0	2	0	0	1	3	0	4	0	0	13
% Buses	0.0%	0.0%	0.0%	0.0%	0.0%	0.0%	0.0%	0.0%	0.0%	0.0%	20.0%	1.9%	0.0%	0.0%	5.4%	0.0%	0.0%	0.0%	0.0%	0.0%	0.0%	13.3%	0.0%	0.0%	8.3%	0.0%	1.0%	7.1%	0.0%	0.0%	4.4%	0.0%	0.0%	4.4%
Pedestrians	0	0	0	0	0	1	1	0	0	0	0	0	0	0	0	0	0	0	0	0	0	0	0	0	0	1	0	0	0	0	0	0	0	0
% Pedestrians	0.0%	0.0%	0.0%	0.0%	0.0%	100.0%	100.0%	0.0%	0.0%	0.0%	0.0%	0.0%	0.0%	0.0%	0.0%	0.0%	0.0%	0.0%	0.0%	0.0%	0.0%	0.0%	0.0%	0.0%	0.0%	0.0%	100.0%	0.0%	0.0%	0.0%	0.0%	0.0%	0.0%	0.0%
Bicycles on Crosswalk	0	0	0	0	0	0	0	0	0	0	0	0	0	0	0	0	0	0	0	0	0	0	0	0	0	0	0	0	0	0	0	0	0	0
% Bicycles on Crosswalk	0.0%	0.0%	0.0%	0.0%	0.0%	0.0%	0.0%	0.0%	0.0%	0.0%	0.0%	0.0%	0.0%	0.0%	0.0%	0.0%	0.0%	0.0%	0.0%	0.0%	0.0%	0.0%	0.0%	0.0%	0.0%	0.0%	0.0%	0.0%	0.0%	0.0%	0.0%	0.0%	0.0%	0.0%

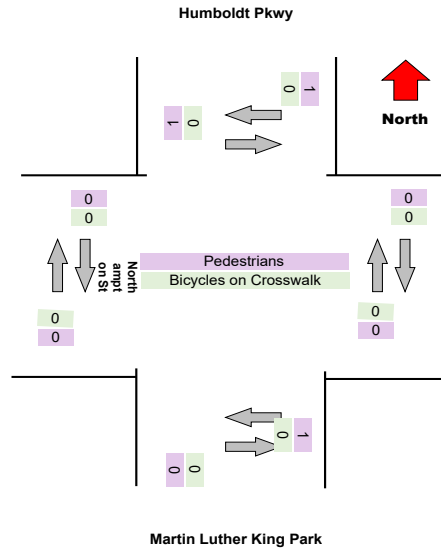
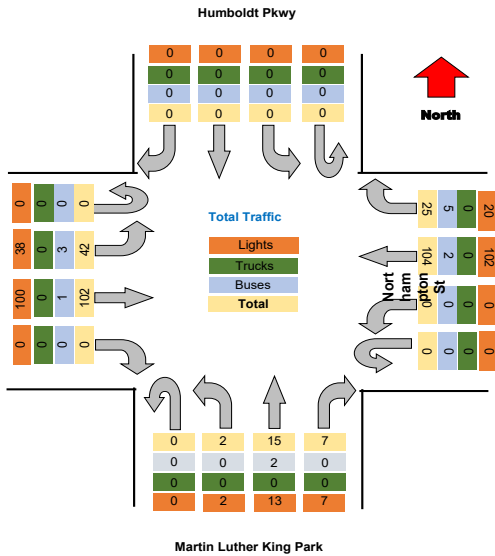

Turning Movement Data Plot

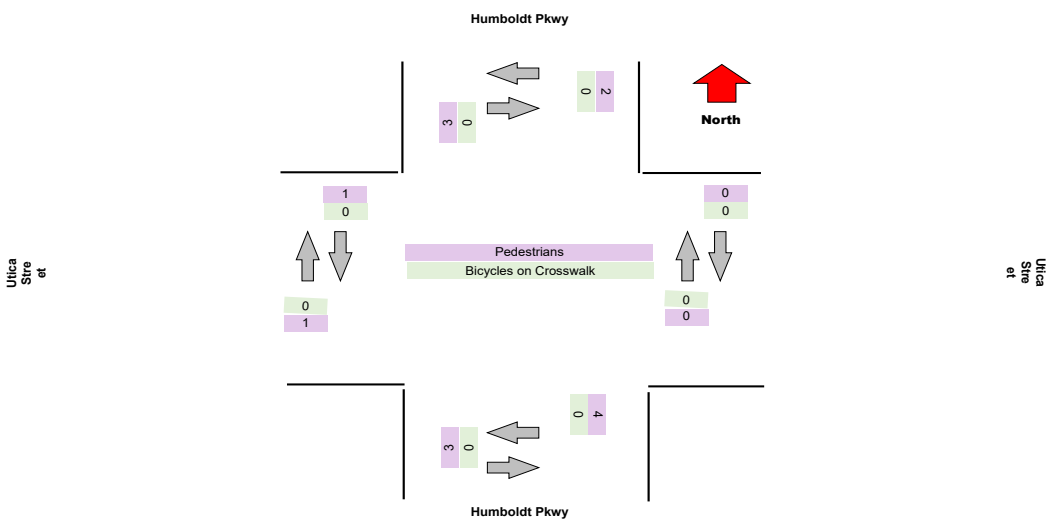
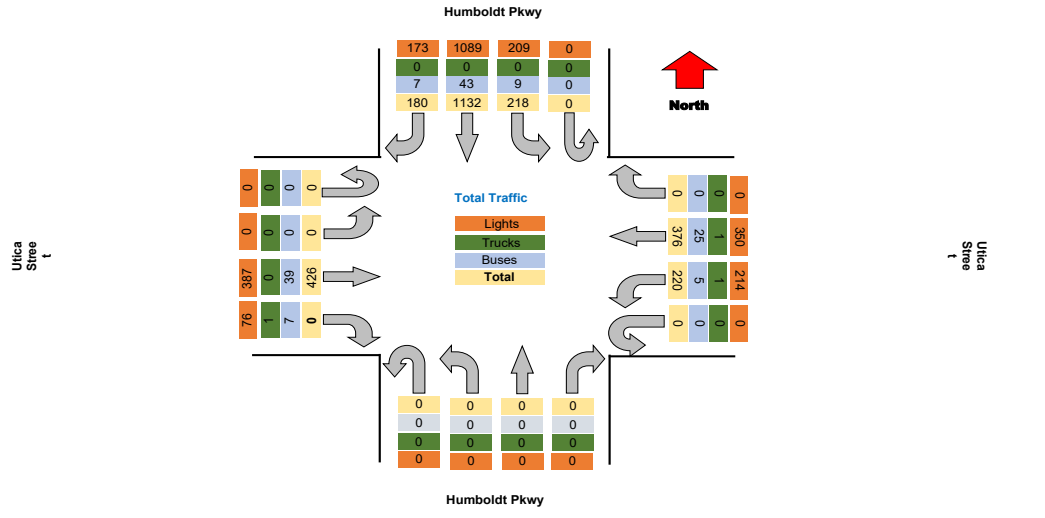

Turning Movement Peak Hour Data (AM)

7:30:00 AM

Leg Direction	Humboldt Pkwy										Utica Street										Humboldt Pkwy										Utica Street										Total
	Southbound					Westbound					Northbound					Eastbound																									
Start Time	Right	Thru	Left	U-Turn	App Total	Peds CW	Peds CCW	Right	Thru	Left	U-Turn	App Total	Peds CW	Peds CCW	Right	Thru	Left	U-Turn	App Total	Peds CW	Peds CCW	Right	Thru	Left	U-Turn	App Total	Peds CW	Peds CCW													
7:30:00 AM	12	76	15	0	103	0	0	0	20	17	0	37	0	0	0	0	0	0	0	1	0	0	3	17	0	0	20	0	1	160											
7:45:00 AM	13	77	11	0	101	0	0	0	22	20	0	42	0	0	0	0	0	0	0	0	0	4	20	0	0	24	0	0	167												
8:00:00 AM	14	58	10	0	82	0	0	0	28	15	0	43	0	0	0	0	0	0	0	0	0	6	26	0	0	32	0	0	157												
8:15:00 AM	8	91	12	0	111	0	0	0	29	8	0	39	0	0	0	0	0	0	0	0	0	5	22	0	0	27	0	0	177												
Grand Total	47	302	48	0	397	0	0	0	99	60	0	159	0	0	0	0	0	0	1	1	0	19	85	0	0	103	3	1	661												
% Approach	11.8%	76.1%	12.1%	0.0%	0.0%	0.0%	0.0%	14.2%	85.8%	0.0%	0.0%	0.0%	0.0%	0.0%	45.1%	41.7%	13.2%	0.0%	0.0%	0.0%	0.0%	0.0%	66.2%	33.8%	0.0%	0.0%	0.0%	0.0%	0.0%												
% Total	7.1%	45.7%	7.3%	0.0%	60.1%	0.0%	0.0%	0.0%	15.0%	9.1%	0.0%	24.4%	0.0%	0.0%	0.0%	0.0%	0.0%	0.0%	0.0%	0.0%	0.0%	2.7%	12.9%	0.0%	0.0%	15.6%	0.0%	0.0%	0.0%												
PHF	0.839	0.830	0.800	0.000	0.894	0.000	0.000	0.000	0.853	0.750	0.000	0.936	0.000	0.000	0.000	0.000	0.000	0.000	0.000	0.000	0.000	0.750	0.817	0.000	0.000	0.805	0.000	0.000	0.934												
Lights	44	287	47	0	378	0	0	0	92	57	0	149	0	0	0	0	0	0	0	0	0	17	73	0	0	90	0	0	617												
% Lights	93.6%	95.0%	97.9%	0.0%	95.2%	0.0%	0.0%	0.0%	92.9%	95.0%	0.0%	92.5%	0.0%	0.0%	0.0%	0.0%	0.0%	0.0%	0.0%	0.0%	0.0%	94.4%	85.9%	0.0%	0.0%	87.4%	0.0%	0.0%	93.3%												
Trucks	0	0	0	0	0	0	0	0	0	0	0	0	0	0	0	0	0	0	0	0	0	0	0	0	0	0	0	0	0												
% Trucks	0.0%	0.0%	0.0%	0.0%	0.0%	0.0%	0.0%	0.0%	0.0%	0.0%	0.0%	0.0%	0.0%	0.0%	0.0%	0.0%	0.0%	0.0%	0.0%	0.0%	0.0%	0.0%	0.0%	0.0%	0.0%	0.0%	0.0%	0.0%	0.0%												
Buses	3	15	1	0	19	0	0	0	7	3	0	10	0	0	0	0	0	0	0	0	0	1	12	0	0	13	0	0	42												
% Buses	6.4%	5.0%	2.1%	0.0%	0.0%	0.0%	0.0%	0.0%	7.1%	5.0%	0.0%	0.0%	0.0%	0.0%	0.0%	0.0%	0.0%	0.0%	0.0%	0.0%	0.0%	5.6%	14.1%	0.0%	0.0%	0.0%	0.0%	0.0%	6.4%												
Pedestrians	0	0	0	0	0	0	2	0	0	0	0	0	0	0	0	0	0	0	1	1	0	0	0	0	0	0	0	1	0												
% Pedestrians	0.0%	0.0%	0.0%	0.0%	0.0%	0.0%	100.0%	0.0%	0.0%	0.0%	0.0%	0.0%	0.0%	0.0%	0.0%	0.0%	0.0%	0.0%	0.0%	100.0%	100.0%	0.0%	0.0%	0.0%	0.0%	0.0%	0.0%	100.0%	0.0%												
Bicycles on Crosswalk	0	0	0	0	0	0	0	0	0	0	0	0	0	0	0	0	0	0	0	0	0	0	0	0	0	0	0	0	0												
% Bicycles on Crosswalk	0.0%	0.0%	0.0%	0.0%	0.0%	0.0%	0.0%	0.0%	0.0%	0.0%	0.0%	0.0%	0.0%	0.0%	0.0%	0.0%	0.0%	0.0%	0.0%	0.0%	0.0%	0.0%	0.0%	0.0%	0.0%	0.0%	0.0%	0.0%	0.0%												

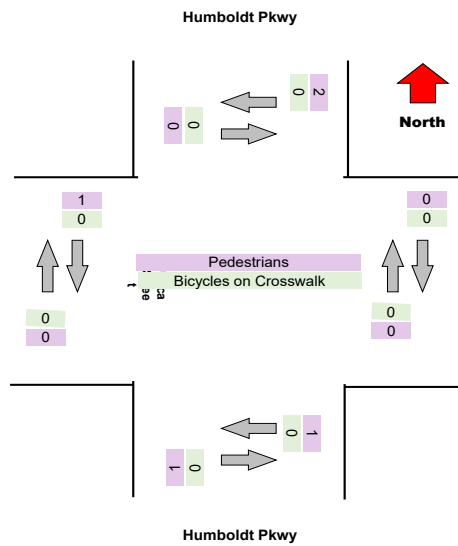
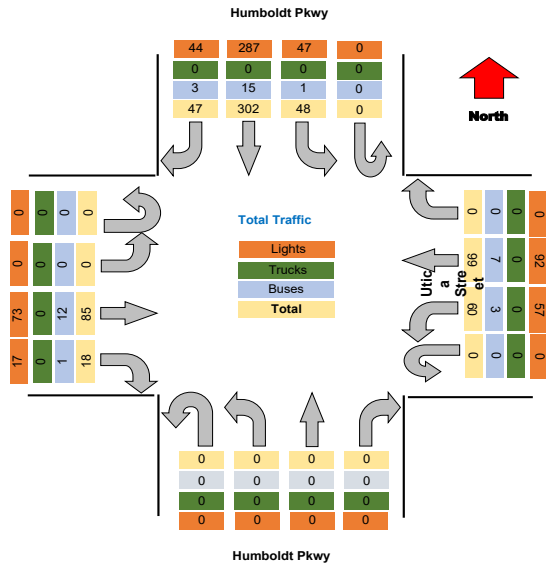

Turning Movement Peak Hour Data (PM)

4:15:00 PM

Leg Direction	Humboldt Pkwy								Utica Street								Humboldt Pkwy								Utica Street								Total
	Southbound				Westbound				Northbound				Eastbound				Southbound				Westbound												
Start Time	Right	Thru	Left	U-Turn	App Total	Peds CW	Peds CCW		Right	Thru	Left	U-Turn	App Total	Peds CW	Peds CCW		Right	Thru	Left	U-Turn	App Total	Peds CW	Peds CCW		Right	Thru	Left	U-Turn	App Total	Peds CW	Peds CCW		
4:15:00 PM	17	89	15	0	121	0	0	0	0	28	14	0	42	0	0	0	0	0	0	0	0	0	0	0	13	39	0	0	52	0	0	0	215
4:30:00 PM	15	94	19	0	128	0	0	0	0	23	12	0	35	0	0	0	0	0	0	0	0	1	0	0	6	37	0	0	43	0	0	0	206
4:45:00 PM	11	87	14	0	112	0	0	0	0	29	10	0	39	0	0	0	0	0	0	0	0	0	0	0	6	33	0	0	39	0	0	0	190
5:00:00 PM	13	87	20	0	120	0	0	0	0	31	16	0	47	0	0	0	0	0	0	0	0	0	0	0	8	29	0	0	37	0	0	0	204
Grand Total	56	357	68	0	481	0	0	0	0	111	52	0	163	0	0	0	0	0	0	0	0	1	0	0	33	138	0	0	171	0	0	0	815
% Approach	11.6%	74.2%	14.1%	0.0%	0.0%	0.0%	0.0%	0.0%	14.2%	85.8%	0.0%	0.0%	0.0%	0.0%	0.0%	0.0%	45.1%	41.7%	13.2%	0.0%	0.0%	0.0%	0.0%	0.0%	0.0%	66.2%	33.8%	0.0%	0.0%	0.0%	0.0%	0.0%	
% Total	6.9%	43.8%	8.3%	0.0%	59.0%	0.0%	0.0%	0.0%	0.0%	13.6%	6.4%	0.0%	20.0%	0.0%	0.0%	0.0%	0.0%	0.0%	0.0%	0.0%	0.0%	0.0%	0.0%	0.0%	4.0%	16.9%	0.0%	0.0%	21.0%	0.0%	0.0%	0.0%	
PHF	0.824	0.949	0.850	0.000	0.939	0.000	0.000	0.000	0.000	0.895	0.813	0.000	0.867	0.000	0.000	0.000	0.000	0.000	0.000	0.000	0.000	0.000	0.000	0.000	0.635	0.885	0.000	0.000	0.822	0.000	0.000	0.000	
Lights	53	347	64	0	464	0	0	0	0	106	51	0	157	0	0	0	0	0	0	0	0	0	0	0	30	133	0	0	163	0	0	0	784
% Lights	84.6%	97.2%	94.1%	0.0%	96.5%	0.0%	0.0%	0.0%	0.0%	95.5%	98.1%	0.0%	96.3%	0.0%	0.0%	0.0%	0.0%	0.0%	0.0%	0.0%	0.0%	0.0%	0.0%	0.0%	90.9%	96.4%	0.0%	0.0%	95.3%	0.0%	0.0%	0.0%	
Trucks	0	0	0	0	0	0	0	0	0	0	0	0	0	0	0	0	0	0	0	0	0	0	0	0	0	0	0	0	0	0	0	0	0
% Trucks	0.0%	0.0%	0.0%	0.0%	0.0%	0.0%	0.0%	0.0%	0.0%	0.0%	0.0%	0.0%	0.0%	0.0%	0.0%	0.0%	0.0%	0.0%	0.0%	0.0%	0.0%	0.0%	0.0%	0.0%	0.0%	0.0%	0.0%	0.0%	0.0%	0.0%	0.0%	0.0%	
Buses	3	10	4	0	17	0	0	0	0	5	1	0	6	0	0	0	0	0	0	0	0	0	0	0	3	5	0	0	8	0	0	0	31
% Buses	5.4%	2.8%	5.9%	0.0%	0.0%	0.0%	0.0%	0.0%	0.0%	4.5%	1.9%	0.0%	0.0%	0.0%	0.0%	0.0%	0.0%	0.0%	0.0%	0.0%	0.0%	0.0%	0.0%	0.0%	9.1%	3.6%	0.0%	0.0%	0.0%	0.0%	0.0%	0.0%	
Pedestrians	0	0	0	0	0	0	0	0	0	0	0	0	0	0	0	0	0	0	0	0	0	1	0	0	0	0	0	0	0	0	0	0	0
% Pedestrians	0.0%	0.0%	0.0%	0.0%	0.0%	0.0%	0.0%	0.0%	0.0%	0.0%	0.0%	0.0%	0.0%	0.0%	0.0%	0.0%	0.0%	0.0%	0.0%	0.0%	0.0%	100.0%	0.0%	0.0%	0.0%	0.0%	0.0%	0.0%	0.0%	0.0%	0.0%	0.0%	
Bicycles on Crosswalk	0	0	0	0	0	0	0	0	0	0	0	0	0	0	0	0	0	0	0	0	0	0	0	0	0	0	0	0	0	0	0	0	0
% Bicycles on Crosswalk	0.0%	0.0%	0.0%	0.0%	0.0%	0.0%	0.0%	0.0%	0.0%	0.0%	0.0%	0.0%	0.0%	0.0%	0.0%	0.0%	0.0%	0.0%	0.0%	0.0%	0.0%	0.0%	0.0%	0.0%	0.0%	0.0%	0.0%	0.0%	0.0%	0.0%	0.0%	0.0%	

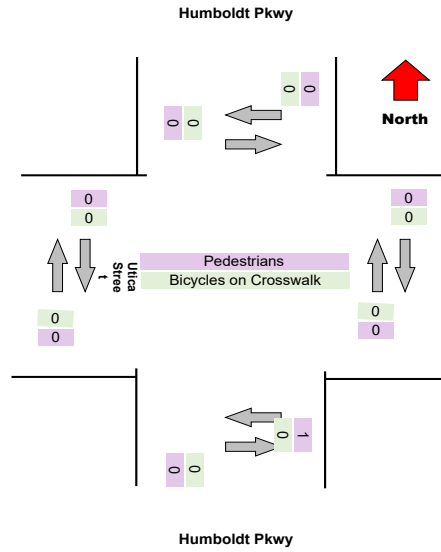
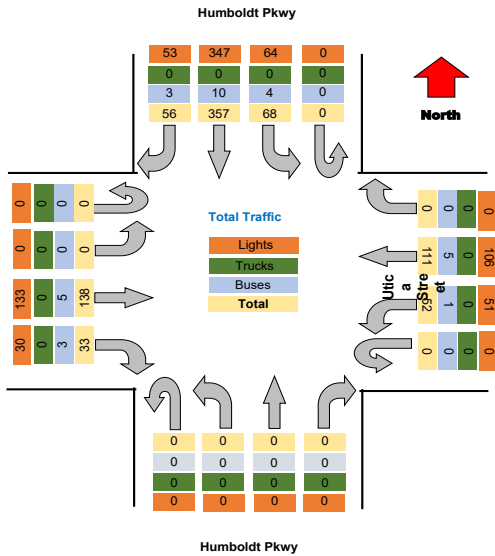

Project : VBH Malta NY
Site : Site 4
Location : 42.948550, -73.790036

TSTData.com

Survey Date : 2021-04-28, Wednesday

Project	Labella
Project Code	Labella
Site Name	6
Legs and Movements	All Processed Legs & Move
Bin Size	15 minutes
Survey Date	2021-10-27, Wednesday
Location	6
Latitude and Longitude	42.911017, -78.843680

	Start	End	PHF
Forced Peak AM	2021/10/27 07:30:00	2021/10/27 08:30:00	0.92
Forced Peak PM	2021/10/27 16:30:00	2021/10/27 17:30:00	0.95
AM Peak	2021/10/27 07:30:00	2021/10/27 08:30:00	0.92
PM Peak	2021/10/27 16:15:00	2021/10/27 17:15:00	0.95

Turning Movement Data

Leg Direction	Humboldt Pkwy										Utica Street										Total
	Southbound					Westbound					Northbound					Eastbound					
	Right	Thru	Left	U-Turn	App Total	Right	Thru	Left	U-Turn	App Total	Right	Thru	Left	U-Turn	App Total	Right	Thru	Left	U-Turn	App Total	
6:30:00 AM	1	38	8	0	47	0	13	7	0	20	0	0	0	0	0	1	7	0	0	8	75
6:45:00 AM	3	40	9	0	52	0	12	8	0	20	0	0	0	0	0	1	13	0	0	14	96
Hourly Total	4	78	17	0	99	0	25	15	0	40	0	0	0	0	0	2	20	0	0	22	191
7:00:00 AM	3	34	5	0	42	0	13	9	0	23	0	0	0	0	0	3	12	0	0	15	80
7:15:00 AM	9	39	14	0	62	0	13	3	0	18	0	0	0	0	1	0	5	20	0	25	105
7:30:00 AM	11	71	16	0	98	0	22	9	0	31	0	0	0	0	0	8	18	0	0	26	155
7:45:00 AM	12	80	6	0	98	0	21	22	0	44	0	0	0	0	0	7	20	0	0	27	169
Hourly Total	35	224	41	0	300	0	69	43	0	116	0	0	0	0	1	23	70	0	0	93	509
8:00:00 AM	16	73	10	0	99	0	24	10	0	34	0	0	0	0	2	6	24	0	0	30	163
8:15:00 AM	13	77	15	0	105	0	33	17	0	50	0	0	0	0	1	5	22	0	0	27	182
Hourly Total	29	150	25	0	204	0	57	27	0	84	0	0	0	0	3	11	46	0	0	57	345
4:00:00 PM	12	82	25	0	119	0	29	17	0	46	0	0	0	0	0	10	51	0	0	61	226
4:15:00 PM	17	90	11	0	118	0	33	15	0	48	0	0	0	0	0	12	45	0	0	57	223
4:30:00 PM	11	96	15	0	122	0	29	18	0	47	0	0	0	0	0	5	46	0	0	51	220
4:45:00 PM	10	64	18	0	92	0	40	14	0	54	0	0	0	0	2	8	45	0	0	53	199
Hourly Total	50	332	69	0	451	0	131	64	0	195	0	0	0	0	2	35	167	0	0	222	673
5:00:00 PM	13	80	18	0	111	0	30	20	0	50	0	0	0	0	0	11	33	0	0	44	205
5:15:00 PM	25	71	21	0	117	0	27	13	0	40	0	0	0	0	0	12	42	0	0	54	211
5:30:00 PM	15	72	4	0	91	0	26	14	0	40	0	0	0	0	3	11	34	0	0	45	176
5:45:00 PM	14	66	17	0	97	0	32	12	0	44	0	0	0	0	2	6	42	0	0	48	189
Hourly Total	67	289	60	0	416	0	115	59	0	174	0	0	0	0	5	40	151	0	0	191	607
Grand Total	185	1073	212	0	1470	0	397	208	0	609	0	0	0	0	11	64	111	474	0	585	2684
% Approach	12.6%	73.0%	14.4%	0.0%	0.0%	0.0%	65.2%	34.2%	0.0%	0.0%	0.0%	0.0%	0.0%	0.0%	0.0%	19.0%	81.0%	0.0%	0.0%	0.0%	0.0%
% Total	6.9%	40.3%	8.0%	0.0%	55.2%	0.0%	14.9%	7.8%	0.0%	22.9%	0.0%	0.0%	0.0%	0.0%	0.0%	4.2%	17.8%	0.0%	0.0%	22.0%	0.0%
Lights	174	1032	208	0	1412	0	370	203	0	573	0	0	0	0	0	103	438	0	0	541	2526
% Lights	94.1%	96.2%	97.2%	0.0%	96.1%	0.0%	93.2%	97.6%	0.0%	94.1%	0.0%	0.0%	0.0%	0.0%	0.0%	92.8%	92.4%	0.0%	0.0%	92.5%	94.6%
Trucks	0	0	0	0	0	0	0	0	0	0	0	0	0	0	0	0	0	0	0	0	0
% Trucks	0.0%	0.0%	0.0%	0.0%	0.0%	0.0%	0.0%	0.0%	0.0%	0.0%	0.0%	0.0%	0.0%	0.0%	0.0%	0.0%	0.0%	0.0%	0.0%	0.0%	0.0%
Buses	11	40	6	0	57	0	27	5	0	32	0	0	0	0	0	8	36	0	0	44	133
% Buses	5.9%	3.7%	2.8%	0.0%	0.0%	0.0%	6.8%	2.4%	0.0%	0.0%	0.0%	0.0%	0.0%	0.0%	0.0%	7.2%	7.6%	0.0%	0.0%	0.0%	5.0%
Pedestrians	0	0	0	0	0	0	0	0	0	0	0	0	0	0	11	0	0	0	0	0	11
% Pedestrians	0.0%	0.0%	0.0%	0.0%	0.0%	0.0%	0.0%	0.0%	0.0%	0.0%	0.0%	0.0%	0.0%	0.0%	100.0%	0.0%	0.0%	0.0%	0.0%	0.0%	83.3%
Bicycles on Crosswalk	0	0	0	0	0	0	0	0	0	0	0	0	0	0	0	0	0	0	0	0	0
% Bicycles on Crosswalk	0.0%	0.0%	0.0%	0.0%	0.0%	0.0%	0.0%	0.0%	0.0%	0.0%	0.0%	0.0%	0.0%	0.0%	0.0%	0.0%	0.0%	0.0%	0.0%	0.0%	18.7%

Project : VBH Malta NY
 Site : Site 4
 Location : 42.948550, -73.790036
 Survey Date : 2021-04-28, Wednesday

Turning Movement Data Plot

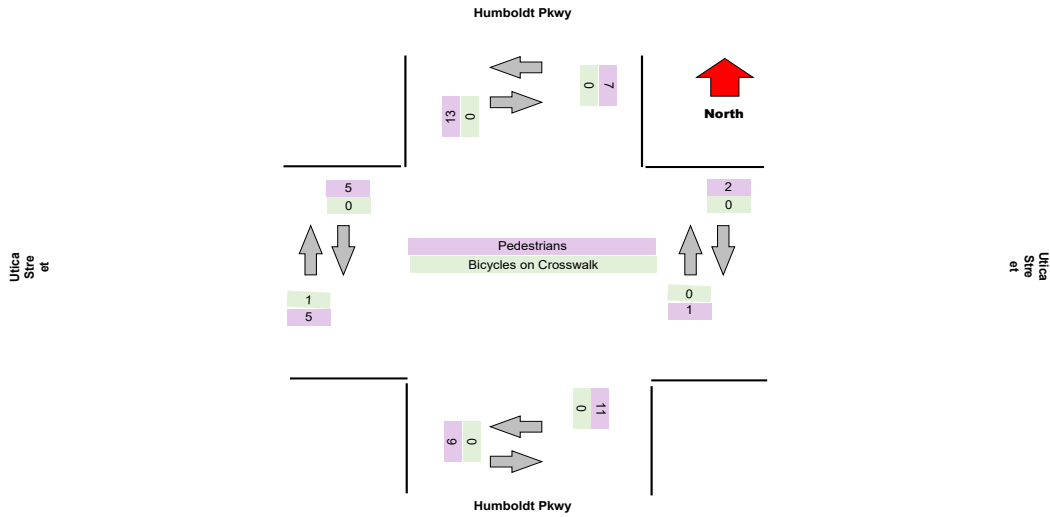
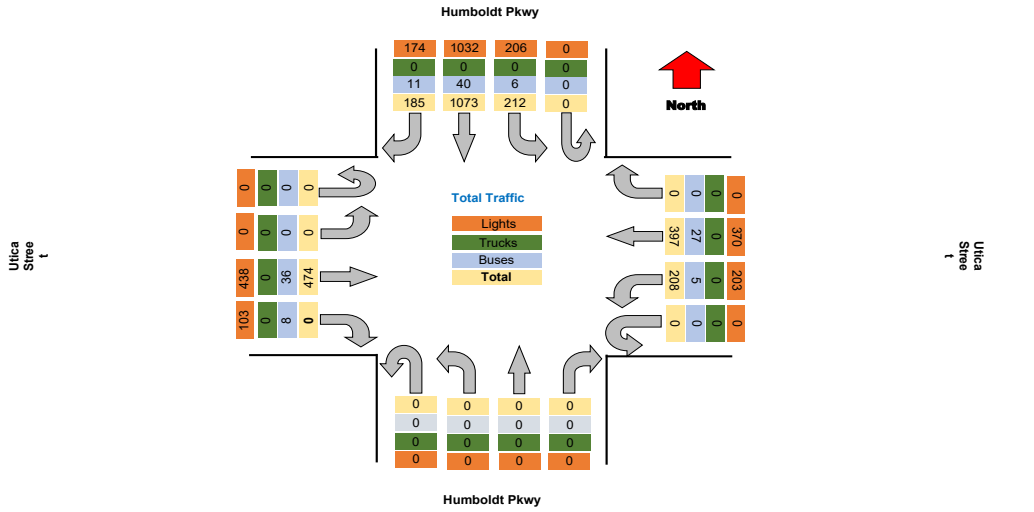

Turning Movement Peak Hour Data (AM)

7:30:00 AM

Leg Direction	Humboldt Pkwy					Ulita Street					Humboldt Pkwy					Ulita Street					Total
	Right	Thru	Left	U-Turn	App Total	Right	Thru	Left	U-Turn	App Total	Right	Thru	Left	U-Turn	App Total	Right	Thru	Left	U-Turn	App Total	
7:30:00 AM	11	71	16	0	98	0	22	9	0	31	0	0	0	0	0	8	18	0	0	26	
7:45:00 AM	12	80	6	0	98	2	21	22	0	44	0	0	0	0	0	7	20	0	0	27	
8:00:00 AM	16	73	10	0	99	1	24	10	0	34	0	0	0	0	2	6	24	0	0	30	
8:15:00 AM	13	77	15	0	105	0	33	17	0	50	0	0	0	0	1	5	22	0	0	27	
Grand Total	52	301	47	0	400	3	100	58	0	159	0	0	0	0	3	26	84	0	0	110	
% Approach	13.0%	75.3%	11.8%	0.0%	0.0%	14.2%	85.8%	0.0%	0.0%	0.0%	45.1%	41.7%	13.2%	0.0%	0.0%	0.0%	66.2%	33.8%	0.0%	0.0%	
% Total	7.8%	45.0%	7.0%	0.0%	58.8%	0.0%	14.9%	8.7%	0.0%	23.8%	0.0%	0.0%	0.0%	0.0%	0.0%	3.9%	12.6%	0.0%	0.0%	16.4%	
PHF	0.813	0.941	0.734	0.000	0.952	0.000	0.000	0.758	0.659	0.000	0.000	0.000	0.000	0.000	0.000	0.813	0.875	0.000	0.000	0.917	
Lights	48	287	45	0	380	0	92	55	0	147	0	0	0	0	0	23	74	0	0	97	
% Lights	92.3%	95.3%	95.7%	0.0%	95.0%	0.0%	92.0%	94.8%	0.0%	92.5%	0.0%	0.0%	0.0%	0.0%	0.0%	88.5%	88.1%	0.0%	0.0%	88.2%	
Trucks	0	0	0	0	0	0	0	0	0	0	0	0	0	0	0	0	0	0	0	0	
% Trucks	0.0%	0.0%	0.0%	0.0%	0.0%	0.0%	0.0%	0.0%	0.0%	0.0%	0.0%	0.0%	0.0%	0.0%	0.0%	0.0%	0.0%	0.0%	0.0%	0.0%	
Buses	4	14	2	0	20	0	8	3	0	11	0	0	0	0	0	3	10	0	0	13	
% Buses	7.7%	4.7%	4.3%	0.0%	0.0%	0.0%	8.0%	5.2%	0.0%	0.0%	0.0%	0.0%	0.0%	0.0%	0.0%	11.5%	11.8%	0.0%	0.0%	6.8%	
Pedestrians	0	0	0	0	0	3	0	0	0	0	0	0	0	0	3	0	0	0	0	3	
% Pedestrians	0.0%	0.0%	0.0%	0.0%	0.0%	100.0%	0.0%	0.0%	0.0%	0.0%	0.0%	0.0%	0.0%	0.0%	0.0%	100.0%	0.0%	0.0%	0.0%	0.0%	
Bicycles on Crosswalk	0	0	0	0	0	0	0	0	0	0	0	0	0	0	0	0	0	0	0	0	
% Bicycles on Crosswalk	0.0%	0.0%	0.0%	0.0%	0.0%	0.0%	0.0%	0.0%	0.0%	0.0%	0.0%	0.0%	0.0%	0.0%	0.0%	0.0%	0.0%	0.0%	0.0%	0.0%	

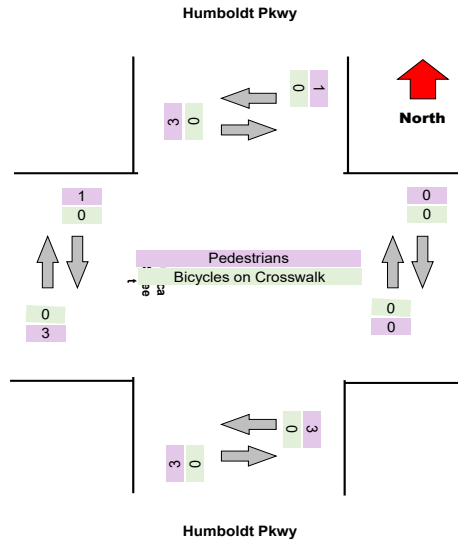
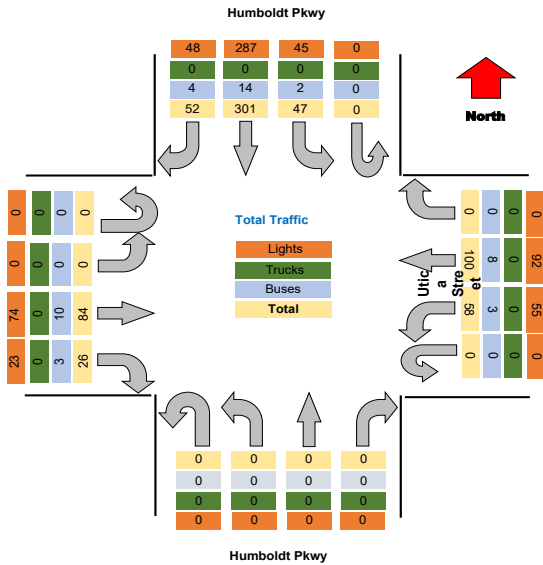

Turning Movement Peak Hour Data (PM)

4:15:00 PM

Leg Direction	Humboldt Pkwy				Utica Street				Humboldt Pkwy				Utica Street				Total											
	Southbound		Northbound		Westbound		Eastbound		Northbound		Southbound		Westbound		Eastbound													
Start Time	Right	Thru	Left	U-Turn	App Total	Peds CW	Peds CCW	Right	Thru	Left	U-Turn	App Total	Peds CW	Peds CCW	Right	Thru	Left	U-Turn	App Total	Peds CW	Peds CCW							
4:15:00 PM	17	90	11	0	118	1	0	0	33	15	0	48	0	0	0	0	0	0	0	12	45	0	0	57	0	0	223	
4:30:00 PM	11	96	15	0	122	1	1	0	29	18	0	47	0	0	0	0	0	0	0	5	46	0	0	51	0	0	220	
4:45:00 PM	10	64	18	0	92	2	2	0	40	14	0	54	2	0	0	0	0	0	2	8	45	0	0	53	0	0	199	
5:00:00 PM	13	60	18	0	111	0	0	0	30	20	0	50	0	0	0	0	0	0	0	11	33	0	0	44	0	1	205	
Grand Total	51	339	62	0	443	4	0	0	132	67	0	199	2	0	0	0	0	0	2	36	169	0	0	205	3	1	847	
% Approach	11.5%	74.5%	14.0%	0.0%	0.0%	0.0%	0.0%	14.2%	85.8%	0.0%	0.0%	0.0%	0.0%	0.0%	45.1%	41.7%	13.2%	0.0%	0.0%	0.0%	66.2%	33.8%	0.0%	0.0%	0.0%	0.0%	0.0%	0.0%
% Total	6.0%	39.0%	7.3%	0.0%	52.3%	0.0%	0.0%	0.0%	15.6%	7.3%	0.0%	23.5%	0.0%	0.0%	0.0%	0.0%	0.0%	0.0%	0.0%	4.3%	20.0%	0.0%	0.0%	24.2%	0.0%	0.0%	0.0%	
PHF	0.750	0.859	0.861	0.000	0.908	0.000	0.000	0.000	0.825	0.838	0.000	0.921	0.000	0.000	0.000	0.000	0.000	0.000	0.000	0.750	0.918	0.000	0.000	0.899	0.000	0.000	0.950	
Lights	49	319	61	0	429	0	0	0	126	66	0	192	0	0	0	0	0	0	0	33	159	0	0	192	0	0	813	
% Lights	96.1%	96.7%	98.4%	0.0%	96.8%	0.0%	0.0%	0.0%	95.5%	98.5%	0.0%	96.5%	0.0%	0.0%	0.0%	0.0%	0.0%	0.0%	0.0%	91.7%	94.1%	0.0%	0.0%	93.7%	0.0%	0.0%	96.0%	
Trucks	0	0	0	0	0	0	0	0	0	0	0	0	0	0	0	0	0	0	0	0	0	0	0	0	0	0	0	
% Trucks	0.0%	0.0%	0.0%	0.0%	0.0%	0.0%	0.0%	0.0%	0.0%	0.0%	0.0%	0.0%	0.0%	0.0%	0.0%	0.0%	0.0%	0.0%	0.0%	0.0%	0.0%	0.0%	0.0%	0.0%	0.0%	0.0%	0.0%	
Buses	2	10	1	0	13	0	0	0	6	1	0	7	0	0	0	0	0	0	0	3	10	0	0	13	0	0	33	
% Buses	3.9%	3.0%	1.6%	0.0%	0.0%	0.0%	0.0%	0.0%	4.5%	1.5%	0.0%	0.0%	0.0%	0.0%	0.0%	0.0%	0.0%	0.0%	0.0%	8.3%	5.9%	0.0%	0.0%	0.0%	0.0%	0.0%	3.9%	
Pedestrians	0	0	0	0	0	4	3	0	0	0	0	0	2	3	0	0	0	0	0	0	0	0	0	0	0	1	0	
% Pedestrians	0.0%	0.0%	0.0%	0.0%	0.0%	100.0%	100.0%	0.0%	0.0%	0.0%	0.0%	0.0%	100.0%	100.0%	0.0%	0.0%	0.0%	0.0%	0.0%	0.0%	0.0%	0.0%	0.0%	0.0%	0.0%	100.0%	0.0%	
Bicycles on Crosswalk	0	0	0	0	0	0	0	0	0	0	0	0	0	0	0	0	0	0	0	0	0	0	0	0	0	0	0	
% Bicycles on Crosswalk	0.0%	0.0%	0.0%	0.0%	0.0%	0.0%	0.0%	0.0%	0.0%	0.0%	0.0%	0.0%	0.0%	0.0%	0.0%	0.0%	0.0%	0.0%	0.0%	0.0%	0.0%	0.0%	0.0%	0.0%	0.0%	0.0%	0.0%	

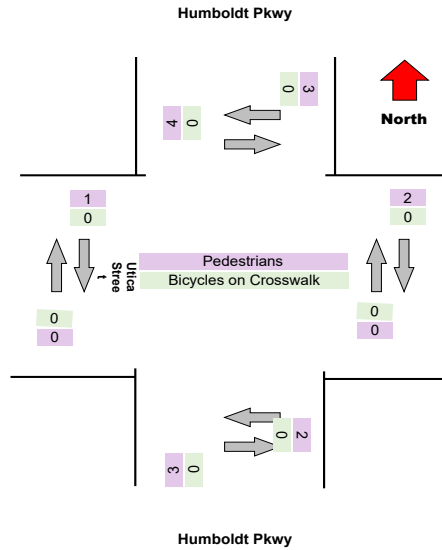
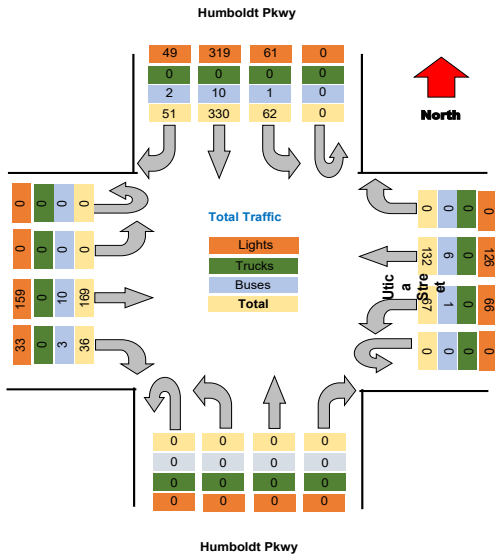

Project : VBH Malta NY
Site : Site 4
Location : 42.948550, -73.790036

TSTData.com

Survey Date : 2021-04-28, Wednesday

Project	Labella
Project Code	Labella
Site Name	6
Legs and Movements	All Processed Legs & Move
Bin Size	15 minutes
Survey Date	2021-10-28, Thursday
Location	6
Latitude and Longitude	42.911017, -78.843680

	Start	End	PHF
Forced Peak AM	2021/10/28 07:30:00	2021/10/28 08:30:00	0.78
Forced Peak PM	2021/10/28 16:30:00	2021/10/28 17:30:00	0.9
AM Peak	2021/10/28 07:30:00	2021/10/28 08:30:00	0.78
PM Peak	2021/10/28 16:15:00	2021/10/28 17:15:00	0.95

Turning Movement Data

Leg Direction	Humboldt Pkwy										Utica Street										Total							
	Southbound					Westbound					Northbound					Eastbound												
	Right	Thru	Left	U-Turn	App Total	Peds CV	Peds CCV	Right	Thru	Left	U-Turn	App Total	Peds CV	Peds CCV	Right	Thru	Left	U-Turn	App Total	Peds CV		Peds CCV						
Start Time																												
6:30:00 AM	6	35	6	0	47	0	1	0	13	9	0	23	0	0	0	0	0	0	0	1	10	0	0	11	0	2	81	
6:45:00 AM	4	45	9	0	58	1	2	0	13	6	0	20	0	0	0	0	0	0	0	1	2	22	0	0	13	0	1	91
Hourly Total	10	80	15	0	105	1	2	0	26	15	0	43	0	0	0	0	0	0	1	2	22	0	0	24	0	3	172	
7:00:00 AM	9	28	7	0	44	2	0	0	11	9	0	20	0	0	0	0	0	0	0	3	22	0	0	25	0	0	89	
7:15:00 AM	8	48	11	0	67	0	0	0	10	11	0	21	0	0	0	0	0	0	2	0	6	11	0	0	17	0	0	105
7:30:00 AM	16	63	13	0	92	0	1	0	19	16	0	36	0	0	0	0	0	0	0	7	17	0	0	24	1	0	162	
7:45:00 AM	18	113	13	0	144	0	0	0	31	21	0	52	0	0	0	0	0	0	0	11	23	0	0	34	1	2	230	
Hourly Total	51	252	44	0	347	2	1	0	71	57	0	129	0	0	0	0	0	0	2	27	73	0	0	100	2	2	576	
8:00:00 AM	13	68	12	0	93	1	0	0	24	15	0	39	0	0	0	0	0	0	0	4	16	0	0	20	0	0	152	
8:15:00 AM	10	89	10	0	109	0	0	0	26	16	0	42	0	0	0	0	0	0	0	9	22	0	0	31	0	0	182	
Hourly Total	23	157	22	0	202	1	0	0	50	31	0	81	0	0	0	0	0	0	0	13	38	0	0	51	0	0	334	
4:00:00 PM	18	108	17	0	143	0	0	0	23	19	0	42	0	0	0	0	0	0	1	10	43	0	0	53	0	0	238	
4:15:00 PM	19	94	25	0	138	4	0	0	23	15	0	38	0	0	0	0	0	0	1	6	48	0	0	54	1	0	230	
4:30:00 PM	14	102	23	0	139	0	2	0	29	13	0	42	0	0	0	0	0	0	0	9	41	0	0	50	0	0	231	
4:45:00 PM	16	87	15	0	118	1	0	0	34	9	0	43	1	0	0	0	0	0	4	8	44	0	0	52	1	0	213	
Hourly Total	67	391	80	0	538	5	2	0	109	56	0	165	1	0	0	0	0	0	5	33	176	0	0	209	2	0	912	
5:00:00 PM	15	71	23	0	109	0	0	0	25	17	0	42	0	0	0	0	0	0	0	7	42	0	0	49	0	1	200	
5:15:00 PM	20	68	18	0	106	0	3	0	27	10	0	37	0	0	0	0	0	0	1	8	41	0	0	49	0	0	192	
5:30:00 PM	15	79	23	0	117	0	3	0	24	23	0	47	0	0	0	0	0	0	4	9	32	0	0	41	0	1	205	
5:45:00 PM	15	79	11	0	105	0	1	0	30	19	0	49	0	0	0	0	0	0	1	11	47	0	0	58	1	0	212	
Hourly Total	65	297	75	0	437	0	7	0	106	69	0	175	0	0	0	0	0	0	1	35	162	0	0	197	1	2	809	
Grand Total	216	1177	236	0	1629	6	12	0	362	228	0	593	1	0	0	0	0	0	8	7	110	471	0	0	581	5	7	2893
% Approach	13.3%	72.3%	14.5%	0.0%	0.0%	0.0%	0.0%	0.0%	61.0%	38.4%	0.0%	0.0%	0.0%	0.0%	0.0%	0.0%	0.0%	0.0%	0.0%	18.9%	81.1%	0.0%	0.0%	0.0%	0.0%	0.0%	0.0%	
% Total	7.7%	42.0%	8.4%	0.0%	58.1%	0.0%	0.0%	0.0%	12.9%	8.1%	0.0%	21.2%	0.0%	0.0%	0.0%	0.0%	0.0%	0.0%	0.0%	3.9%	16.8%	0.0%	0.0%	20.7%	0.0%	0.0%	0.0%	
Lights	204	1138	232	0	1574	0	0	0	340	221	0	561	0	0	0	0	0	0	0	101	439	0	0	540	0	0	2675	
% Lights	94.4%	96.7%	98.3%	0.0%	96.6%	0.0%	0.0%	0.0%	93.9%	96.9%	0.0%	94.6%	0.0%	0.0%	0.0%	0.0%	0.0%	0.0%	0.0%	91.6%	93.2%	0.0%	0.0%	92.9%	0.0%	0.0%	95.4%	
Trucks	0	1	0	0	1	0	0	0	0	0	0	0	0	0	0	0	0	0	0	0	0	0	0	0	0	0	1	
% Trucks	0.0%	0.1%	0.0%	0.0%	0.1%	0.0%	0.0%	0.0%	0.0%	0.0%	0.0%	0.0%	0.0%	0.0%	0.0%	0.0%	0.0%	0.0%	0.0%	0.0%	0.0%	0.0%	0.0%	0.0%	0.0%	0.0%	0.0%	
Buses	12	37	4	0	53	0	0	0	22	7	0	29	0	0	0	0	0	0	0	9	31	0	0	40	0	0	122	
% Buses	5.6%	3.1%	1.7%	0.0%	0.0%	0.0%	0.0%	0.0%	6.1%	3.1%	0.0%	0.0%	0.0%	0.0%	0.0%	0.0%	0.0%	0.0%	0.0%	8.2%	6.6%	0.0%	0.0%	0.0%	0.0%	0.0%	4.4%	
Pedestrians	0	0	0	0	0	9	12	0	0	0	0	0	1	0	0	0	0	0	8	7	0	0	0	0	4	6	0	
% Pedestrians	0.0%	0.0%	0.0%	0.0%	0.0%	100.0%	100.0%	0.0%	0.0%	0.0%	0.0%	0.0%	100.0%	0.0%	0.0%	0.0%	0.0%	0.0%	0.0%	100.0%	100.0%	0.0%	0.0%	0.0%	0.0%	80.0%	85.7%	0.0%
Bicycles on Crosswalk	0	0	0	0	0	0	0	0	0	0	0	0	0	0	0	0	0	0	0	0	0	0	0	0	1	1	0	
% Bicycles on Crosswalk	0.0%	0.0%	0.0%	0.0%	0.0%	0.0%	0.0%	0.0%	0.0%	0.0%	0.0%	0.0%	0.0%	0.0%	0.0%	0.0%	0.0%	0.0%	0.0%	0.0%	0.0%	0.0%	0.0%	0.0%	20.0%	14.3%	0.0%	

Turning Movement Data Plot

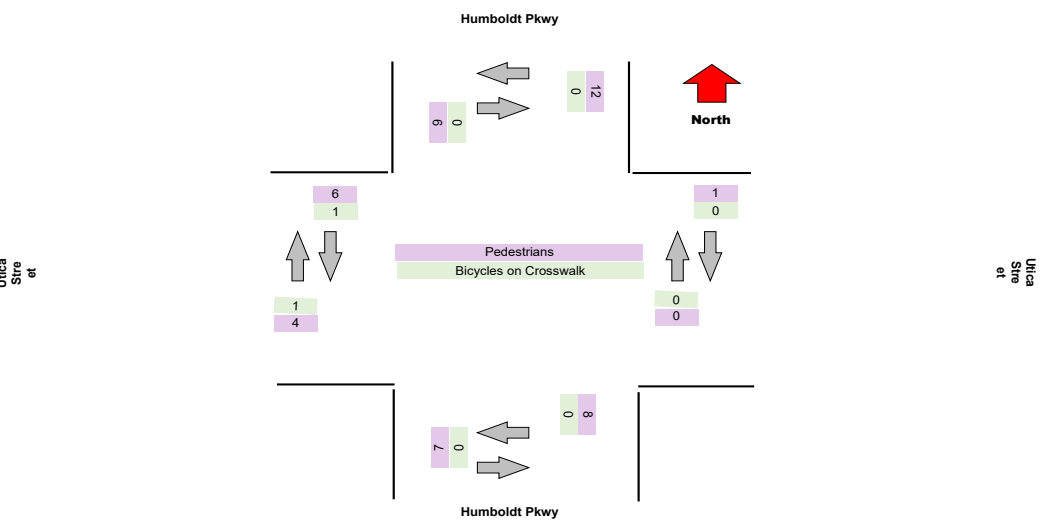
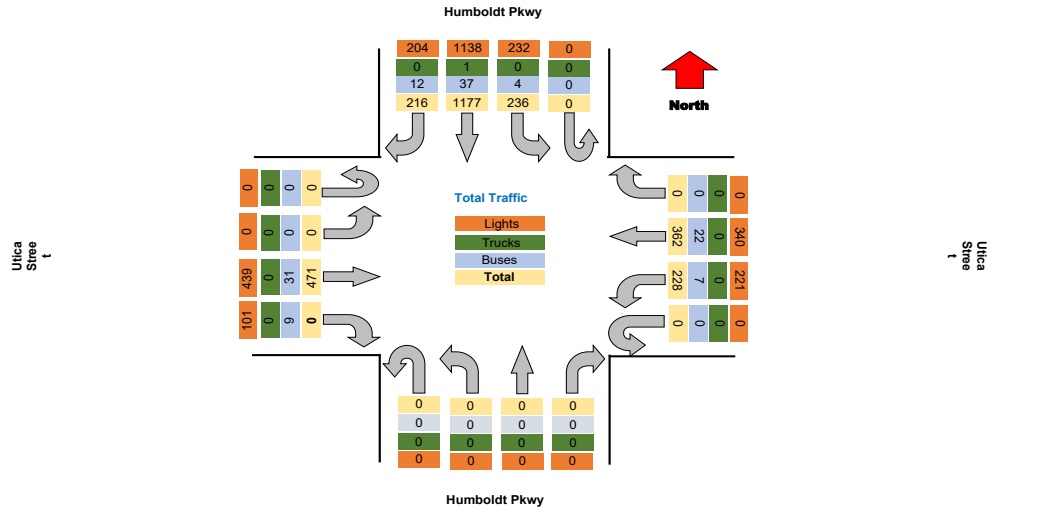

Turning Movement Peak Hour Data (AM)

7:30:00 AM

Leg Direction	Humboldt Pkwy				Utica Street				Humboldt Pkwy				Utica Street				Total					
	Southbound		Westbound		Northbound		Eastbound															
Start Time	Right	Thru	Left	U-Turn	App Total	Peds CW	Peds CCW	Right	Thru	Left	U-Turn	App Total	Peds CW	Peds CCW	Right	Thru	Left	U-Turn	App Total	Peds CW	Peds CCW	
7:30:00 AM	16	63	13	0	92	0	1	0	19	16	0	36	0	0	0	0	0	0	0	24	1	0
7:45:00 AM	18	113	13	0	144	0	0	0	31	21	0	52	0	0	0	0	0	0	0	34	1	2
8:00:00 AM	13	68	12	0	93	1	0	0	24	15	0	39	0	0	0	0	0	0	0	20	0	0
8:15:00 AM	10	69	10	0	109	0	0	0	25	16	0	42	0	0	0	0	0	0	0	31	0	0
Grand Total	57	333	48	0	438	1	0	0	100	88	0	189	0	0	0	0	0	0	109	2	2	
% Approach	13.0%	76.0%	11.0%	0.0%	0.0%	0.0%	0.0%	14.2%	85.8%	0.0%	0.0%	0.0%	45.1%	41.7%	13.2%	0.0%	0.0%	0.0%	0.0%	66.2%	33.8%	0.0%
% Total	8.0%	46.5%	6.7%	0.0%	61.2%	0.0%	0.0%	0.0%	14.0%	9.5%	0.0%	23.6%	0.0%	0.0%	0.0%	0.0%	0.0%	0.0%	0.0%	4.3%	10.9%	0.0%
PHF	0.792	0.737	0.923	0.000	0.760	0.000	0.000	0.000	0.806	0.810	0.000	0.813	0.000	0.000	0.000	0.000	0.000	0.000	0.000	0.705	0.848	0.000
Lights	54	319	47	0	420	0	0	0	93	64	0	157	0	0	0	0	0	0	0	98	0	0
% Lights	94.7%	95.8%	97.9%	0.0%	95.9%	0.0%	0.0%	0.0%	93.0%	94.1%	0.0%	92.9%	0.0%	0.0%	0.0%	0.0%	0.0%	0.0%	0.0%	87.1%	91.0%	0.0%
Trucks	0	1	0	0	1	0	0	0	0	0	0	0	0	0	0	0	0	0	0	0	0	0
% Trucks	0.0%	0.3%	0.0%	0.0%	0.2%	0.0%	0.0%	0.0%	0.0%	0.0%	0.0%	0.0%	0.0%	0.0%	0.0%	0.0%	0.0%	0.0%	0.0%	0.0%	0.0%	0.0%
Buses	3	13	1	0	17	0	0	0	7	4	0	11	0	0	0	0	0	0	0	4	7	0
% Buses	5.3%	3.9%	2.1%	0.0%	0.0%	0.0%	0.0%	0.0%	7.0%	5.9%	0.0%	0.0%	0.0%	0.0%	0.0%	0.0%	0.0%	0.0%	0.0%	12.9%	9.0%	0.0%
Pedestrians	0	0	0	0	0	1	1	0	0	0	0	0	0	0	0	0	0	0	0	0	2	2
% Pedestrians	0.0%	0.0%	0.0%	0.0%	0.0%	100.0%	100.0%	0.0%	0.0%	0.0%	0.0%	0.0%	0.0%	0.0%	0.0%	0.0%	0.0%	0.0%	0.0%	0.0%	100.0%	100.0%
Bicycles on Crosswalk	0	0	0	0	0	0	0	0	0	0	0	0	0	0	0	0	0	0	0	0	0	0
% Bicycles on Crosswalk	0.0%	0.0%	0.0%	0.0%	0.0%	0.0%	0.0%	0.0%	0.0%	0.0%	0.0%	0.0%	0.0%	0.0%	0.0%	0.0%	0.0%	0.0%	0.0%	0.0%	0.0%	0.0%

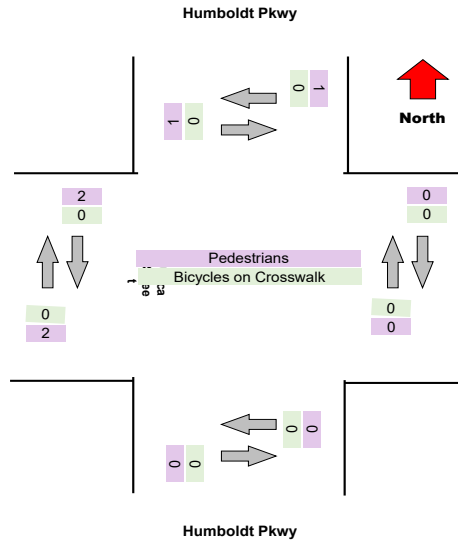
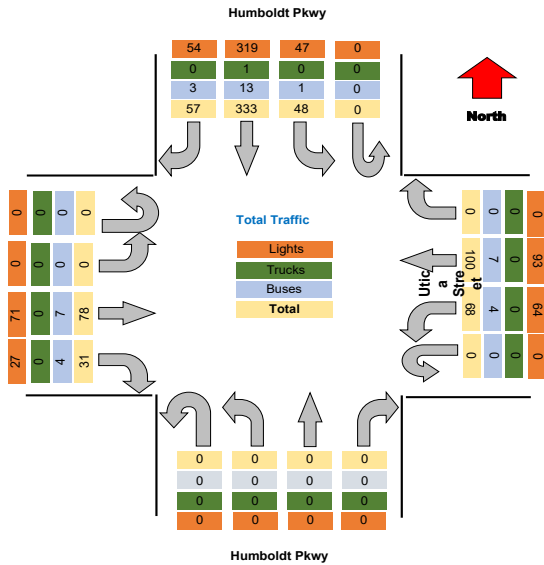

Turning Movement Peak Hour Data (PM)

4:15:00 PM

Leg Direction	Humboldt Pkwy					Utica Street					Humboldt Pkwy					Utica Street					Total		
	Southbound					Westbound					Northbound					Eastbound							
Start Time	Right	Thru	Left	U-Turn	App Total	Peds CW	Peds CCW	Right	Thru	Left	U-Turn	App Total	Peds CW	Peds CCW	Right	Thru	Left	U-Turn	App Total	Peds CW	Peds CCW	Total	
4:15:00 PM	19	94	25	0	138	4	0	0	23	15	0	38	0	0	0	0	0	0	0	1	0	0	230
4:30:00 PM	14	102	23	0	139	0	2	0	29	13	0	42	0	0	0	0	0	0	0	0	0	0	231
4:45:00 PM	16	87	15	0	118	1	0	0	34	9	0	43	1	0	0	0	0	0	0	4	0	0	213
5:00:00 PM	15	71	23	0	109	0	0	0	25	17	0	42	0	0	0	0	0	0	0	0	0	0	200
Grand Total	64	354	86	0	504	5	2	0	111	54	0	165	1	0	0	0	0	0	39	175	0	0	874
% Approach	12.7%	79.2%	17.1%	0.0%	0.0%	0.0%	0.0%	14.2%	85.8%	0.0%	0.0%	0.0%	0.0%	0.0%	45.1%	41.7%	13.2%	0.0%	0.0%	0.0%	0.0%	0.0%	0.0%
% Total	7.3%	40.5%	9.8%	0.0%	57.7%	0.0%	0.0%	0.0%	12.7%	6.2%	0.0%	18.9%	0.0%	0.0%	0.0%	0.0%	0.0%	0.0%	0.0%	0.0%	0.0%	0.0%	0.0%
PHF	0.842	0.868	0.860	0.000	0.906	0.000	0.000	0.000	0.816	0.794	0.000	0.959	0.000	0.000	0.000	0.000	0.000	0.000	0.000	0.833	0.911	0.000	0.846
Lights	61	342	84	0	487	0	0	0	106	53	0	159	0	0	0	0	0	0	0	0	0	0	841
% Lights	85.3%	96.6%	97.7%	0.0%	96.6%	0.0%	0.0%	0.0%	95.5%	98.1%	0.0%	96.4%	0.0%	0.0%	0.0%	0.0%	0.0%	0.0%	0.0%	0.0%	0.0%	0.0%	96.2%
Trucks	0	0	0	0	0	0	0	0	0	0	0	0	0	0	0	0	0	0	0	0	0	0	0
% Trucks	0.0%	0.0%	0.0%	0.0%	0.0%	0.0%	0.0%	0.0%	0.0%	0.0%	0.0%	0.0%	0.0%	0.0%	0.0%	0.0%	0.0%	0.0%	0.0%	0.0%	0.0%	0.0%	0.0%
Buses	3	11	2	0	16	0	0	0	5	1	0	6	0	0	0	0	0	0	0	0	0	0	31
% Buses	4.7%	3.1%	2.3%	0.0%	0.0%	0.0%	0.0%	0.0%	4.5%	1.9%	0.0%	0.0%	0.0%	0.0%	0.0%	0.0%	0.0%	0.0%	0.0%	0.0%	0.0%	0.0%	3.5%
Pedestrians	0	0	0	0	0	5	2	0	0	0	0	1	0	0	0	0	0	0	0	0	0	0	0
% Pedestrians	0.0%	0.0%	0.0%	0.0%	0.0%	100.0%	100.0%	0.0%	0.0%	0.0%	0.0%	0.0%	100.0%	0.0%	0.0%	0.0%	0.0%	0.0%	0.0%	0.0%	0.0%	0.0%	0.0%
Bicycles on Crosswalk	0	0	0	0	0	0	0	0	0	0	0	0	0	0	0	0	0	0	0	0	0	1	1
% Bicycles on Crosswalk	0.0%	0.0%	0.0%	0.0%	0.0%	0.0%	0.0%	0.0%	0.0%	0.0%	0.0%	0.0%	0.0%	0.0%	0.0%	0.0%	0.0%	0.0%	0.0%	0.0%	0.0%	50.0%	100.0%

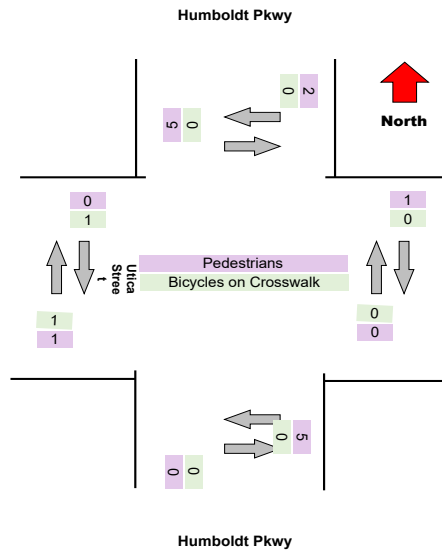
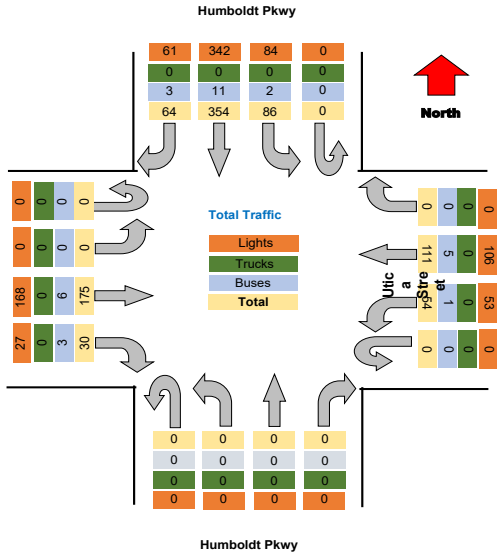

Turning Movement Data Plot

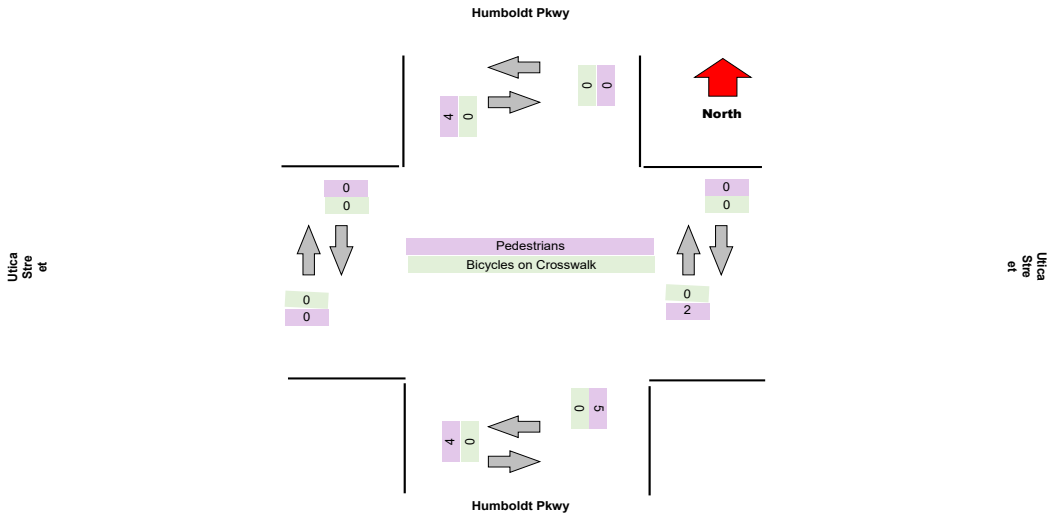
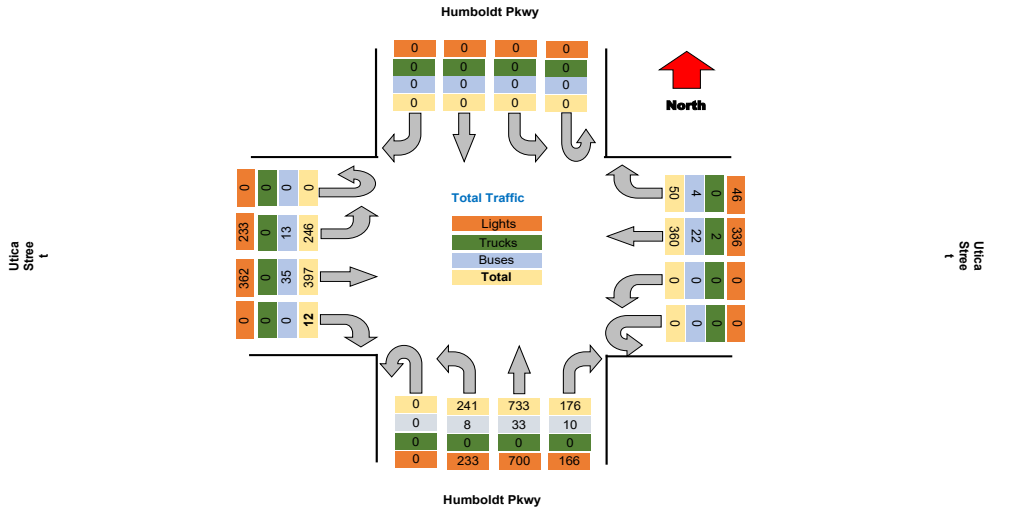

Turning Movement Peak Hour Data (AM)

7:30:00 AM

Leg Direction	Humboldt Pkwy							Ulica Street							Humboldt Pkwy							Ulica Street							Total
	Southbound				Westbound			Northbound				Eastbound			Northbound				Eastbound										
Start Time	Right	Thru	Left	U-Turn	App Total	Peds CW	Peds CCW	Right	Thru	Left	U-Turn	App Total	Peds CW	Peds CCW	Right	Thru	Left	U-Turn	App Total	Peds CW	Peds CCW	Right	Thru	Left	U-Turn	App Total	Peds CW	Peds CCW	
7:30:00 AM	0	0	0	0	0	0	0	5	19	0	0	24	0	0	12	39	14	0	65	1	0	0	17	12	0	29	0	0	
7:45:00 AM	0	0	0	0	0	0	0	2	33	0	0	35	0	0	11	52	13	0	76	0	0	0	21	13	0	34	0	0	
8:00:00 AM	0	0	0	0	0	0	0	2	29	0	0	31	0	0	12	47	15	0	74	1	0	0	22	15	0	37	0	0	
8:15:00 AM	0	0	0	0	0	0	0	5	29	0	0	25	0	1	3	57	16	0	77	0	1	0	21	12	0	33	0	0	
Grand Total	0	0	0	0	0	0	0	14	101	0	0	115	0	1	38	195	58	0	292	2	1	0	81	52	0	133	0	0	
% Approach	#DIV/0!	#DIV/0!	#DIV/0!	#DIV/0!	0.0%	0.0%	0.0%	14.2%	85.8%	0.0%	0.0%	0.0%	0.0%	0.0%	45.1%	41.7%	13.2%	0.0%	0.0%	0.0%	0.0%	0.0%	66.2%	33.8%	0.0%	0.0%	0.0%	0.0%	
% Total	0.0%	0.0%	0.0%	0.0%	0.0%	0.0%	0.0%	2.6%	18.7%	0.0%	0.0%	21.3%	0.0%	0.0%	7.0%	36.1%	10.7%	0.0%	54.1%	0.0%	0.0%	0.0%	15.0%	9.6%	0.0%	24.6%	0.0%	0.0%	
PHF	0.000	0.000	0.000	0.000	0.000	0.000	0.000	0.700	0.785	0.000	0.000	0.821	0.000	0.000	0.792	0.855	0.906	0.000	0.848	0.000	0.000	0.000	0.920	0.867	0.000	0.899	0.000	0.000	
Lights	0	0	0	0	0	0	0	11	94	0	0	105	0	0	35	184	55	0	274	0	0	0	71	49	0	120	0	0	
% Lights	0.0%	0.0%	0.0%	0.0%	0.0%	0.0%	0.0%	78.6%	93.1%	0.0%	0.0%	91.3%	0.0%	0.0%	82.1%	94.4%	94.8%	0.0%	93.8%	0.0%	0.0%	0.0%	87.7%	94.2%	0.0%	90.2%	0.0%	0.0%	
Trucks	0	0	0	0	0	0	0	0	0	0	0	0	0	0	0	0	0	0	0	0	0	0	0	0	0	0	0	0	
% Trucks	0.0%	0.0%	0.0%	0.0%	0.0%	0.0%	0.0%	0.0%	0.0%	0.0%	0.0%	0.0%	0.0%	0.0%	0.0%	0.0%	0.0%	0.0%	0.0%	0.0%	0.0%	0.0%	0.0%	0.0%	0.0%	0.0%	0.0%	0.0%	
Buses	0	0	0	0	0	0	0	3	7	0	0	10	0	0	3	11	3	0	17	0	0	0	10	3	0	13	0	0	
% Buses	0.0%	0.0%	0.0%	0.0%	0.0%	0.0%	0.0%	21.4%	6.9%	0.0%	0.0%	0.0%	0.0%	0.0%	7.9%	5.6%	5.2%	0.0%	0.0%	0.0%	0.0%	0.0%	12.3%	5.8%	0.0%	0.0%	0.0%	0.0%	
Pedestrians	0	0	0	0	0	0	0	0	0	0	0	0	1	0	0	0	0	0	2	1	0	0	0	0	0	0	0	0	
% Pedestrians	0.0%	0.0%	0.0%	0.0%	0.0%	0.0%	0.0%	0.0%	0.0%	0.0%	0.0%	0.0%	100.0%	0.0%	0.0%	0.0%	0.0%	0.0%	0.0%	100.0%	100.0%	0.0%	0.0%	0.0%	0.0%	0.0%	0.0%	0.0%	
Bicycles on Crosswalk	0	0	0	0	0	0	0	0	0	0	0	0	0	0	0	0	0	0	0	0	0	0	0	0	0	0	0	0	
% Bicycles on Crosswalk	0.0%	0.0%	0.0%	0.0%	0.0%	0.0%	0.0%	0.0%	0.0%	0.0%	0.0%	0.0%	0.0%	0.0%	0.0%	0.0%	0.0%	0.0%	0.0%	0.0%	0.0%	0.0%	0.0%	0.0%	0.0%	0.0%	0.0%	0.0%	

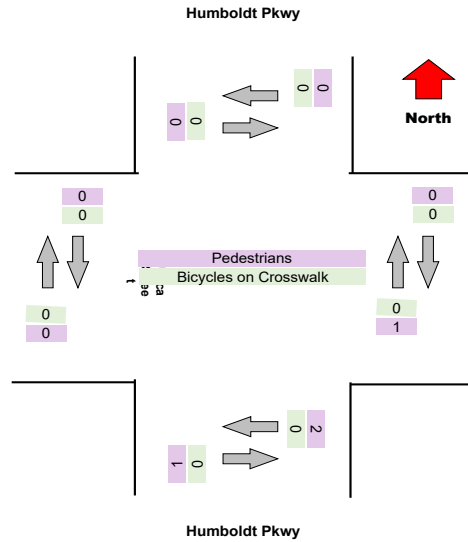
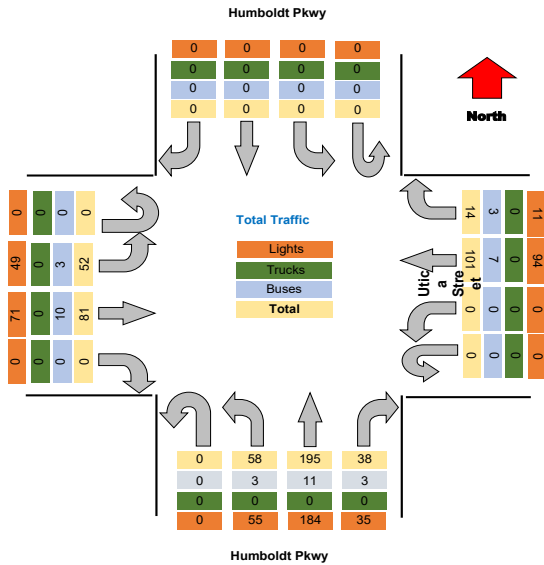

Turning Movement Peak Hour Data (PM)

4:15:00 PM

Leg Direction	Humboldt Pkwy					Ulica Street					Humboldt Pkwy					Ulica Street					Total									
	Southbound					Westbound					Northbound					Eastbound														
Start Time	Right	Thru	Left	U-Turn	App Total	Peds CW	Peds CCW	Right	Thru	Left	U-Turn	App Total	Peds CW	Peds CCW	Right	Thru	Left	U-Turn	App Total	Peds CW	Peds CCW	Total								
4:15:00 PM	0	0	0	0	0	0	0	5	24	0	0	29	0	0	0	13	54	17	0	84	0	0	0	48						
4:30:00 PM	0	0	0	0	0	0	0	4	19	0	0	23	0	0	0	21	45	11	0	77	1	0	0	62						
4:45:00 PM	0	0	0	0	0	0	0	6	20	0	0	26	0	0	0	17	62	20	0	99	0	0	0	49						
5:00:00 PM	0	0	0	0	0	0	0	6	26	0	0	32	0	0	0	8	54	24	0	86	0	0	0	49						
Grand Total	0	0	0	0	0	0	0	21	89	0	0	110	0	0	0	59	215	72	0	346	1	0	0	208						
% Approach	#DIV/0!	#DIV/0!	#DIV/0!	#DIV/0!	0.0%	0.0%	0.0%	14.2%	85.8%	0.0%	0.0%	0.0%	45.1%	41.7%	13.2%	0.0%	0.0%	0.0%	0.0%	0.0%	0.0%	0.0%	0.0%	66.2%	33.8%	0.0%	0.0%	0.0%		
% Total	0.0%	0.0%	0.0%	0.0%	0.0%	0.0%	0.0%	3.2%	13.4%	0.0%	0.0%	16.6%	0.0%	0.0%	0.0%	8.9%	32.4%	10.8%	0.0%	52.1%	0.0%	0.0%	0.0%	31.3%	0.0%	0.0%	0.0%	0.0%	0.0%	
PHF	0.000	0.000	0.000	0.000	0.000	0.000	0.000	0.875	0.856	0.000	0.000	0.859	0.000	0.000	0.000	0.702	0.867	0.750	0.000	0.874	0.000	0.000	0.000	0.839	0.000	0.000	0.000	0.854	0.000	
Lights	0	0	0	0	0	0	0	20	84	0	0	104	0	0	0	56	203	71	0	330	0	0	0	198	0	0	0	632	0	
% Lights	0.0%	0.0%	0.0%	0.0%	0.0%	0.0%	0.0%	85.2%	94.4%	0.0%	0.0%	94.5%	0.0%	0.0%	0.0%	94.9%	94.4%	98.6%	0.0%	95.4%	0.0%	0.0%	0.0%	95.2%	0.0%	0.0%	0.0%	95.2%	0.0%	
Trucks	0	0	0	0	0	0	0	0	0	0	0	0	0	0	0	0	0	0	0	0	0	0	0	0	0	0	0	0	0	
% Trucks	0.0%	0.0%	0.0%	0.0%	0.0%	0.0%	0.0%	0.0%	0.0%	0.0%	0.0%	0.0%	0.0%	0.0%	0.0%	0.0%	0.0%	0.0%	0.0%	0.0%	0.0%	0.0%	0.0%	0.0%	0.0%	0.0%	0.0%	0.0%	0.0%	
Buses	0	0	0	0	0	1	5	0	0	0	0	6	3	12	1	0	16	0	0	0	0	9	1	0	10	0	0	0	32	0
% Buses	0.0%	0.0%	0.0%	0.0%	0.0%	4.8%	5.6%	0.0%	0.0%	0.0%	0.0%	0.0%	5.1%	5.6%	1.4%	0.0%	0.0%	0.0%	0.0%	0.0%	6.3%	1.5%	0.0%	0.0%	4.8%	0.0%	0.0%	4.8%	0.0%	
Pedestrians	0	0	0	0	0	0	0	0	0	0	0	0	0	0	0	0	1	0	0	0	0	0	0	0	0	0	0	0	0	
% Pedestrians	0.0%	0.0%	0.0%	0.0%	0.0%	0.0%	0.0%	0.0%	0.0%	0.0%	0.0%	0.0%	0.0%	0.0%	0.0%	0.0%	0.0%	100.0%	0.0%	0.0%	0.0%	0.0%	0.0%	0.0%	0.0%	0.0%	0.0%	0.0%	0.0%	
Bicycles on Crosswalk	0	0	0	0	0	0	0	0	0	0	0	0	0	0	0	0	0	0	0	0	0	0	0	0	0	0	0	0	0	
% Bicycles on Crosswalk	0.0%	0.0%	0.0%	0.0%	0.0%	0.0%	0.0%	0.0%	0.0%	0.0%	0.0%	0.0%	0.0%	0.0%	0.0%	0.0%	0.0%	0.0%	0.0%	0.0%	0.0%	0.0%	0.0%	0.0%	0.0%	0.0%	0.0%	0.0%	0.0%	

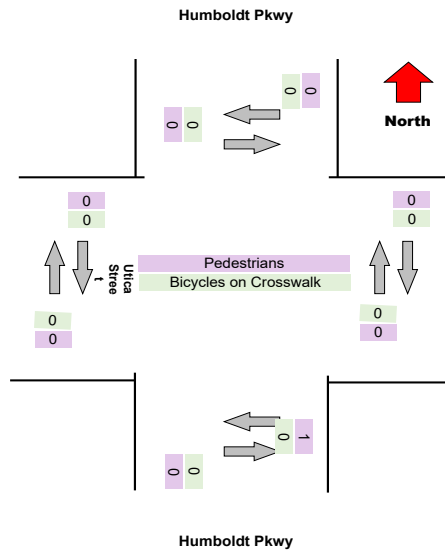
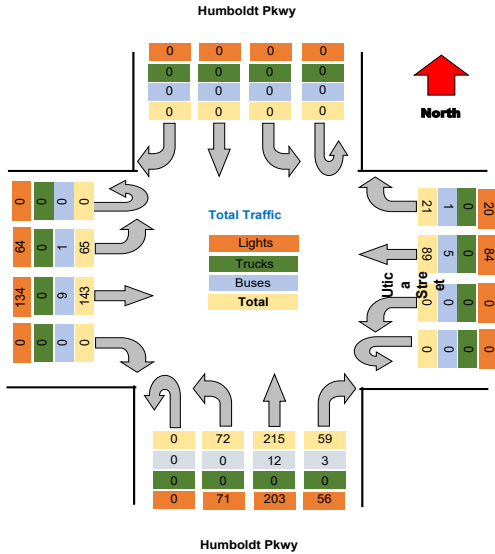

Turning Movement Data Plot

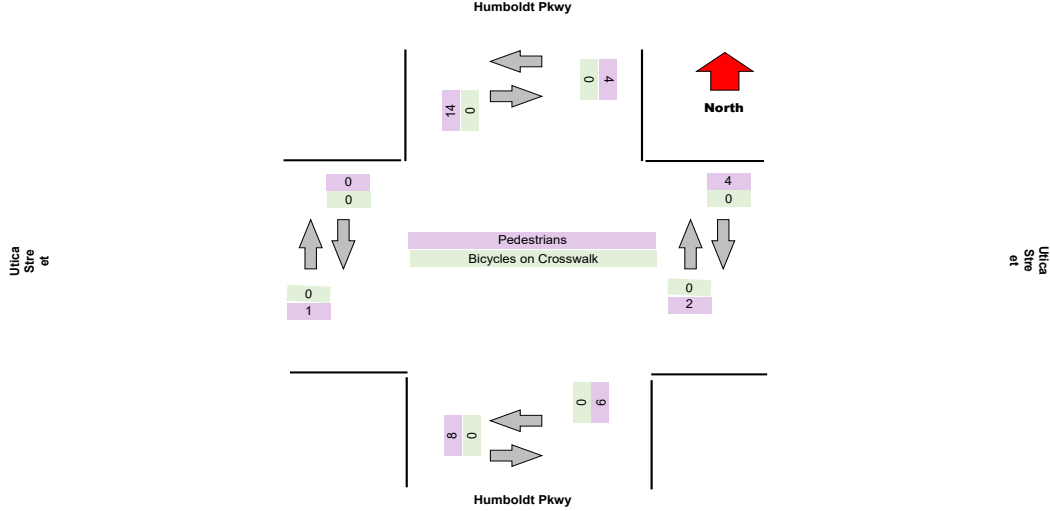
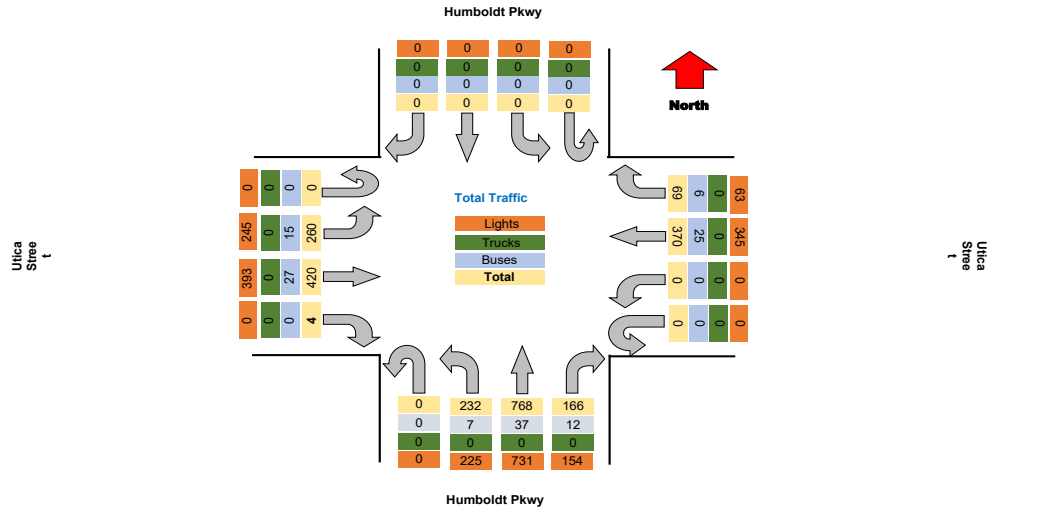

Turning Movement Peak Hour Data (AM)

7:30:00 AM

Leg Direction	Humboldt Pkwy							Utica Street							Humboldt Pkwy							Utica Street							Total
	Southbound				Westbound			Northbound				Eastbound			Northbound				Eastbound										
Start Time	Right	Thru	Left	U-Turn	App Total	Peds CW	Peds CCW	Right	Thru	Left	U-Turn	App Total	Peds CW	Peds CCW	Right	Thru	Left	U-Turn	App Total	Peds CW	Peds CCW	Right	Thru	Left	U-Turn	App Total	Peds CW	Peds CCW	
7:30:00 AM	0	0	0	0	0	0	0	1	17	0	0	18	0	0	4	44	14	0	62	0	0	0	24	8	0	32	0	0	
7:45:00 AM	0	0	0	0	0	2	1	4	28	0	0	33	0	0	10	54	12	0	76	0	2	0	17	16	0	33	0	0	
8:00:00 AM	0	0	0	0	0	0	0	3	20	0	0	23	2	0	11	64	17	0	94	2	0	0	20	15	0	35	0	0	
8:15:00 AM	0	0	0	0	0	0	0	2	27	0	0	29	0	0	7	36	18	0	61	1	1	0	21	13	0	34	0	0	
Grand Total	0	0	0	0	0	2	1	10	92	0	0	103	2	0	32	198	61	0	293	3	3	0	82	52	0	134	3	0	
% Approach	#DIV/0!	#DIV/0!	#DIV/0!	#DIV/0!	0.0%	0.0%	0.0%	14.2%	85.8%	0.0%	0.0%	0.0%	0.0%	0.0%	45.1%	41.7%	13.2%	0.0%	0.0%	0.0%	0.0%	0.0%	66.2%	33.8%	0.0%	0.0%	0.0%	0.0%	
% Total	0.0%	0.0%	0.0%	0.0%	0.0%	0.0%	0.0%	1.9%	17.4%	0.0%	0.0%	19.4%	0.0%	0.0%	6.0%	37.4%	11.5%	0.0%	55.3%	0.0%	0.0%	0.0%	15.5%	9.8%	0.0%	25.3%	0.0%	0.0%	
PHF	0.000	0.000	0.000	0.000	0.000	0.000	0.000	0.625	0.821	0.000	0.000	0.789	0.000	0.000	0.727	0.773	0.847	0.000	0.779	0.000	0.000	0.000	0.854	0.813	0.000	0.957	0.000	0.000	
Lights	0	0	0	0	0	0	0	7	84	0	0	91	0	0	29	187	58	0	274	0	0	0	73	49	0	122	0	0	
% Lights	0.0%	0.0%	0.0%	0.0%	0.0%	0.0%	0.0%	70.0%	91.3%	0.0%	0.0%	88.3%	0.0%	0.0%	90.6%	94.4%	95.1%	0.0%	93.5%	0.0%	0.0%	0.0%	89.0%	94.2%	0.0%	91.0%	0.0%	0.0%	
Trucks	0	0	0	0	0	0	0	0	0	0	0	0	0	0	0	0	0	0	0	0	0	0	0	0	0	0	0	0	
% Trucks	0.0%	0.0%	0.0%	0.0%	0.0%	0.0%	0.0%	0.0%	0.0%	0.0%	0.0%	0.0%	0.0%	0.0%	0.0%	0.0%	0.0%	0.0%	0.0%	0.0%	0.0%	0.0%	0.0%	0.0%	0.0%	0.0%	0.0%	0.0%	
Buses	0	0	0	0	0	0	0	3	8	0	0	11	0	0	3	11	3	0	17	0	0	0	9	3	0	12	0	0	
% Buses	0.0%	0.0%	0.0%	0.0%	0.0%	0.0%	0.0%	30.0%	8.7%	0.0%	0.0%	0.0%	0.0%	0.0%	9.4%	5.6%	4.9%	0.0%	0.0%	0.0%	0.0%	0.0%	11.0%	5.8%	0.0%	0.0%	0.0%	0.0%	
Pedestrians	0	0	0	0	2	1	0	0	0	0	0	2	0	0	0	0	0	0	3	3	0	0	0	0	0	0	0	0	
% Pedestrians	0.0%	0.0%	0.0%	0.0%	0.0%	100.0%	100.0%	0.0%	0.0%	0.0%	0.0%	0.0%	100.0%	0.0%	0.0%	0.0%	0.0%	0.0%	0.0%	100.0%	100.0%	0.0%	0.0%	0.0%	0.0%	0.0%	0.0%	0.0%	
Bicycles on Crosswalk	0	0	0	0	0	0	0	0	0	0	0	0	0	0	0	0	0	0	0	0	0	0	0	0	0	0	0	0	
% Bicycles on Crosswalk	0.0%	0.0%	0.0%	0.0%	0.0%	0.0%	0.0%	0.0%	0.0%	0.0%	0.0%	0.0%	0.0%	0.0%	0.0%	0.0%	0.0%	0.0%	0.0%	0.0%	0.0%	0.0%	0.0%	0.0%	0.0%	0.0%	0.0%	0.0%	

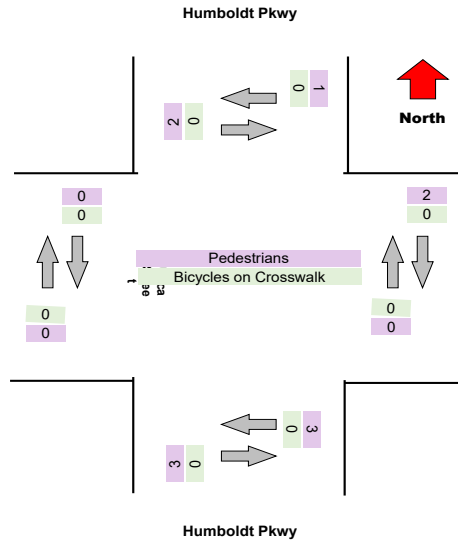
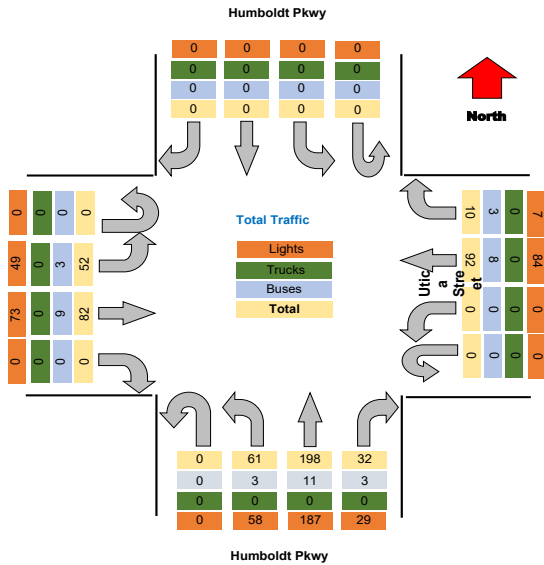

Project : VBH Malta NY
Site : Site 4
Location : 42.948550, -73.790036

TSTData.com

Survey Date : 2021-04-28, Wednesday

Turning Movement Peak Hour Data (PM)

4:15:00 PM

Leg Direction	Humboldt Pkwy										Utica Street										Total																		
	Southbound					Westbound					Northbound					Eastbound																							
	Right	Thru	Left	U-Turn	App Total	Peds CW	Peds CCW	Right	Thru	Left	U-Turn	App Total	Peds CW	Peds CCW	Right	Thru	Left	U-Turn	App Total	Peds CW		Peds CCW																	
4:15:00 PM	0	0	0	0	0	0	1	0	0	0	6	26	0	0	32	0	0	0	0	0	19	71	24	0	114	0	0	0	0	0	56	0	0	0	0	202			
4:30:00 PM	0	0	0	0	0	0	1	0	0	0	11	33	0	0	44	0	0	0	0	0	18	56	12	0	86	1	1	0	0	0	40	25	0	0	65	196			
4:45:00 PM	0	0	0	0	0	0	2	2	0	0	5	36	0	0	41	0	0	0	0	0	14	48	21	0	83	0	2	0	0	0	46	19	0	0	65	189			
5:00:00 PM	0	0	0	0	0	0	0	0	0	0	6	27	0	0	33	0	0	0	0	0	11	47	16	0	74	0	0	0	0	0	31	17	0	0	48	155			
Grand Total	0	0	0	0	0	0	4	2	0	0	28	122	0	0	150	0	0	0	0	0	62	222	73	0	357	1	3	0	0	0	156	79	0	0	234	741			
% Approach	#DIV/0!	#DIV/0!	#DIV/0!	#DIV/0!	0.0%	0.0%	0.0%	0.0%	0.0%	0.0%	14.2%	85.8%	0.0%	0.0%	0.0%	0.0%	0.0%	0.0%	0.0%	0.0%	45.1%	41.7%	13.2%	0.0%	0.0%	0.0%	0.0%	0.0%	0.0%	0.0%	0.0%	66.2%	33.8%	0.0%	0.0%	0.0%	0.0%	0.0%	
% Total	0.0%	0.0%	0.0%	0.0%	0.0%	0.0%	0.0%	0.0%	0.0%	0.0%	3.8%	16.5%	0.0%	0.0%	20.2%	0.0%	0.0%	0.0%	0.0%	0.0%	8.4%	30.0%	9.9%	0.0%	48.2%	0.0%	0.0%	0.0%	0.0%	0.0%	0.0%	21.1%	10.5%	0.0%	31.6%	0.0%	0.0%	0.0%	
PHF	0.000	0.000	0.000	0.000	0.000	0.000	0.000	0.000	0.000	0.000	0.636	0.847	0.000	0.000	0.852	0.000	0.000	0.000	0.000	0.000	0.816	0.782	0.760	0.000	0.783	0.000	0.000	0.000	0.000	0.000	0.000	0.848	0.780	0.000	0.900	0.000	0.000	0.000	
Lights	0	0	0	0	0	0	0	0	0	0	27	116	0	0	143	0	0	0	0	0	57	207	72	0	336	0	0	0	0	0	0	148	75	0	223	0	0	0	
% Lights	0.0%	0.0%	0.0%	0.0%	0.0%	0.0%	0.0%	0.0%	0.0%	0.0%	96.4%	95.1%	0.0%	0.0%	95.3%	0.0%	0.0%	0.0%	0.0%	0.0%	91.9%	93.2%	98.6%	0.0%	94.1%	0.0%	0.0%	0.0%	0.0%	0.0%	0.0%	94.9%	96.2%	0.0%	95.3%	0.0%	0.0%	0.0%	
Trucks	0	0	0	0	0	0	0	0	0	0	0	0	0	0	0	0	0	0	0	0	0	0	0	0	0	0	0	0	0	0	0	0	0	0	0	0	0	0	
% Trucks	0.0%	0.0%	0.0%	0.0%	0.0%	0.0%	0.0%	0.0%	0.0%	0.0%	0.0%	0.0%	0.0%	0.0%	0.0%	0.0%	0.0%	0.0%	0.0%	0.0%	0.0%	0.0%	0.0%	0.0%	0.0%	0.0%	0.0%	0.0%	0.0%	0.0%	0.0%	0.0%	0.0%	0.0%	0.0%	0.0%	0.0%	0.0%	
Buses	0	0	0	0	0	0	0	0	0	0	1	6	0	0	7	0	0	0	0	0	5	15	1	0	21	0	0	0	0	0	0	8	3	0	11	0	0	0	
% Buses	0.0%	0.0%	0.0%	0.0%	0.0%	0.0%	0.0%	0.0%	0.0%	0.0%	3.6%	4.9%	0.0%	0.0%	0.0%	0.0%	0.0%	0.0%	0.0%	0.0%	8.1%	6.8%	1.4%	0.0%	0.0%	0.0%	0.0%	0.0%	0.0%	0.0%	0.0%	5.1%	3.8%	0.0%	0.0%	0.0%	0.0%	0.0%	
Pedestrians	0	0	0	0	0	4	2	0	0	0	0	0	0	0	0	0	0	0	0	1	3	0	0	0	0	0	0	0	0	0	0	0	0	0	0	1	0	0	0
% Pedestrians	0.0%	0.0%	0.0%	0.0%	0.0%	100.0%	100.0%	0.0%	0.0%	0.0%	0.0%	0.0%	0.0%	0.0%	0.0%	0.0%	0.0%	0.0%	0.0%	0.0%	0.0%	0.0%	0.0%	0.0%	0.0%	100.0%	100.0%	0.0%	0.0%	0.0%	0.0%	100.0%	100.0%	0.0%	0.0%	0.0%	0.0%	0.0%	
Bicycles on Crosswalk	0	0	0	0	0	0	0	0	0	0	0	0	0	0	0	0	0	0	0	0	0	0	0	0	0	0	0	0	0	0	0	0	0	0	0	0	0	0	
% Bicycles on Crosswalk	0.0%	0.0%	0.0%	0.0%	0.0%	0.0%	0.0%	0.0%	0.0%	0.0%	0.0%	0.0%	0.0%	0.0%	0.0%	0.0%	0.0%	0.0%	0.0%	0.0%	0.0%	0.0%	0.0%	0.0%	0.0%	0.0%	0.0%	0.0%	0.0%	0.0%	0.0%	0.0%	0.0%	0.0%	0.0%	0.0%	0.0%	0.0%	

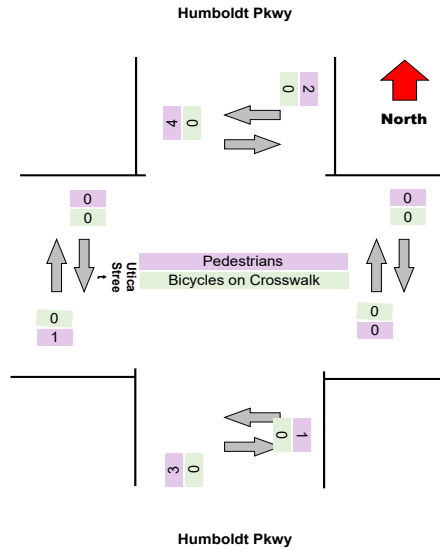
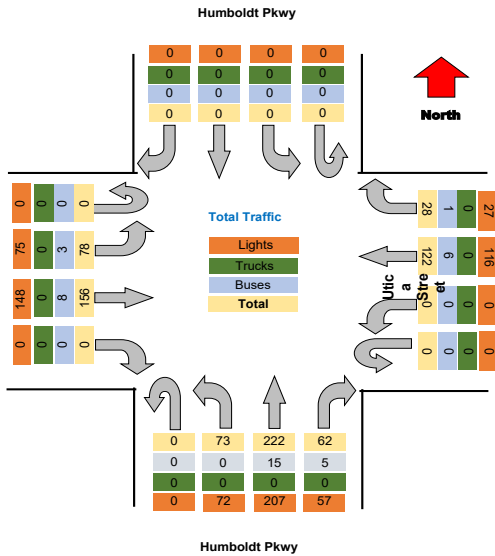

Project : VBH Malta NY
 Site : Site 4
 Location : 42.948550, -73.790036
 Survey Date : 2021-04-28, Wednesday

Turning Movement Data Plot

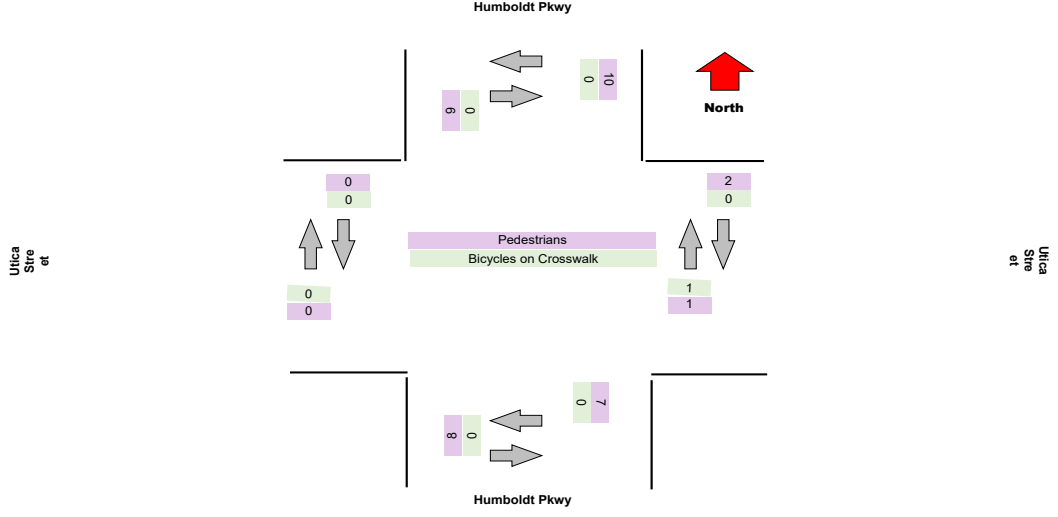
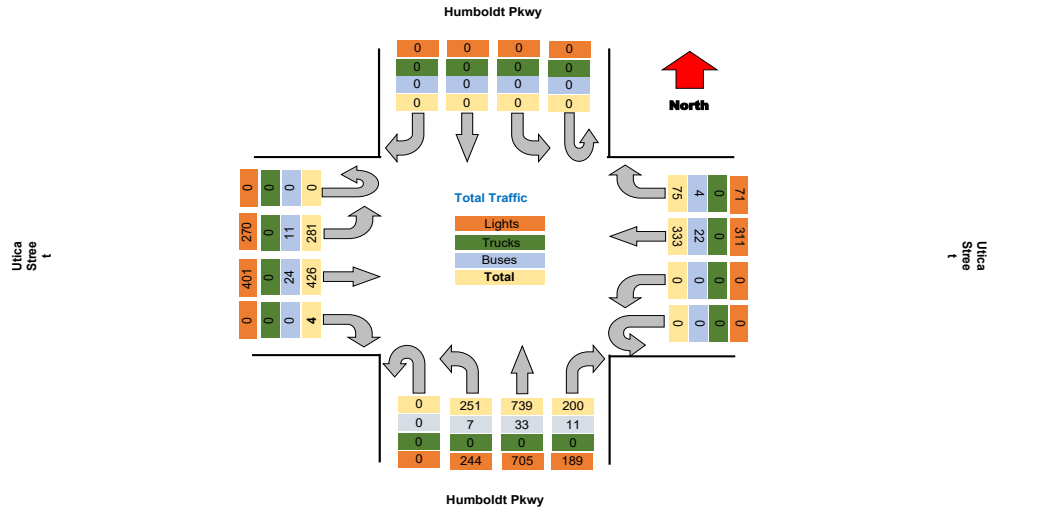

Project : VBH Malta NY
Site : Site 4
Location : 42.948550, -73.790036

TSTData.com

Survey Date : 2021-04-28, Wednesday

Turning Movement Peak Hour Data (AM)

7:30:00 AM

Leg Direction	Humboldt Pkwy							Utica Street							Humboldt Pkwy							Utica Street							Total
	Southbound			Westbound				Northbound			Eastbound				Northbound			Eastbound											
Start Time	Right	Thru	Left	U-Turn	App Total	Peds CW	Peds CCW	Right	Thru	Left	U-Turn	App Total	Peds CW	Peds CCW	Right	Thru	Left	U-Turn	App Total	Peds CW	Peds CCW	Right	Thru	Left	U-Turn	App Total	Peds CW	Peds CCW	
7:30:00 AM	0	0	0	0	0	0	0	5	22	0	0	27	0	0	4	33	14	0	51	0	0	0	15	16	0	31	0	0	
7:45:00 AM	0	0	0	0	0	0	1	4	33	0	0	38	0	0	14	62	19	0	95	0	0	0	23	8	0	31	0	0	
8:00:00 AM	0	0	0	0	0	1	0	5	22	0	0	27	0	0	20	60	17	0	97	0	0	0	20	15	0	35	0	0	
8:15:00 AM	0	0	0	0	0	0	0	2	21	0	0	23	0	0	10	44	19	0	73	0	0	0	23	8	0	31	0	0	
Grand Total	0	0	0	0	1	0	0	16	98	0	0	115	0	0	48	199	69	0	316	0	0	0	81	47	0	128	0	0	
% Approach	#DIV/0!	#DIV/0!	#DIV/0!	#DIV/0!	0.0%	0.0%	0.0%	14.2%	85.8%	0.0%	0.0%	0.0%	0.0%	0.0%	45.1%	41.7%	13.2%	0.0%	0.0%	0.0%	0.0%	0.0%	66.2%	33.8%	0.0%	0.0%	0.0%	0.0%	
% Total	0.0%	0.0%	0.0%	0.0%	0.0%	0.0%	0.0%	2.9%	17.5%	0.0%	0.0%	20.6%	0.0%	0.0%	8.6%	35.6%	12.3%	0.0%	56.5%	0.0%	0.0%	0.0%	14.5%	8.4%	0.0%	22.9%	0.0%	0.0%	
PHF	0.000	0.000	0.000	0.000	0.000	0.000	0.000	0.800	0.742	0.000	0.000	0.757	0.000	0.000	0.600	0.802	0.908	0.000	0.814	0.000	0.000	0.000	0.880	0.734	0.000	0.914	0.000	0.000	
Lights	0	0	0	0	0	0	0	13	90	0	0	103	0	0	45	187	66	0	298	0	0	0	75	45	0	120	0	0	
% Lights	0.0%	0.0%	0.0%	0.0%	0.0%	0.0%	0.0%	81.3%	91.8%	0.0%	0.0%	89.6%	0.0%	0.0%	93.8%	94.0%	95.7%	0.0%	94.3%	0.0%	0.0%	0.0%	92.6%	95.7%	0.0%	93.8%	0.0%	0.0%	
Trucks	0	0	0	0	0	0	0	0	0	0	0	0	0	0	0	0	0	0	0	0	0	0	0	0	0	0	0	0	
% Trucks	0.0%	0.0%	0.0%	0.0%	0.0%	0.0%	0.0%	0.0%	0.0%	0.0%	0.0%	0.0%	0.0%	0.0%	0.0%	0.0%	0.0%	0.0%	0.0%	0.0%	0.0%	0.0%	0.0%	0.0%	0.0%	0.0%	0.0%	0.0%	
Buses	0	0	0	0	0	0	0	3	8	0	0	11	0	0	3	12	3	0	18	0	0	0	6	2	0	8	0	0	
% Buses	0.0%	0.0%	0.0%	0.0%	0.0%	0.0%	0.0%	18.8%	8.2%	0.0%	0.0%	0.0%	0.0%	0.0%	6.3%	6.0%	4.3%	0.0%	0.0%	0.0%	0.0%	7.4%	4.3%	0.0%	0.0%	0.0%	0.0%		
Pedestrians	0	0	0	0	0	1	1	0	0	0	0	0	0	0	0	0	0	0	0	0	0	0	0	0	0	0	0	0	
% Pedestrians	0.0%	0.0%	0.0%	0.0%	0.0%	100.0%	100.0%	0.0%	0.0%	0.0%	0.0%	0.0%	0.0%	0.0%	0.0%	0.0%	0.0%	0.0%	0.0%	0.0%	0.0%	0.0%	0.0%	0.0%	0.0%	0.0%	0.0%	0.0%	
Bicycles on Crosswalk	0	0	0	0	0	0	0	0	0	0	0	0	0	0	0	0	0	0	0	0	0	0	0	0	0	0	0	0	
% Bicycles on Crosswalk	0.0%	0.0%	0.0%	0.0%	0.0%	0.0%	0.0%	0.0%	0.0%	0.0%	0.0%	0.0%	0.0%	0.0%	0.0%	0.0%	0.0%	0.0%	0.0%	0.0%	0.0%	0.0%	0.0%	0.0%	0.0%	0.0%	0.0%	0.0%	

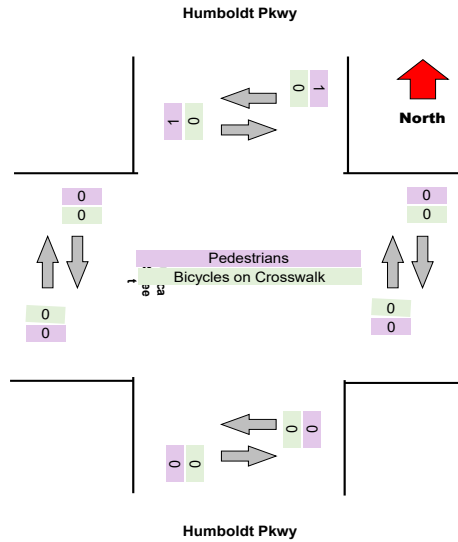
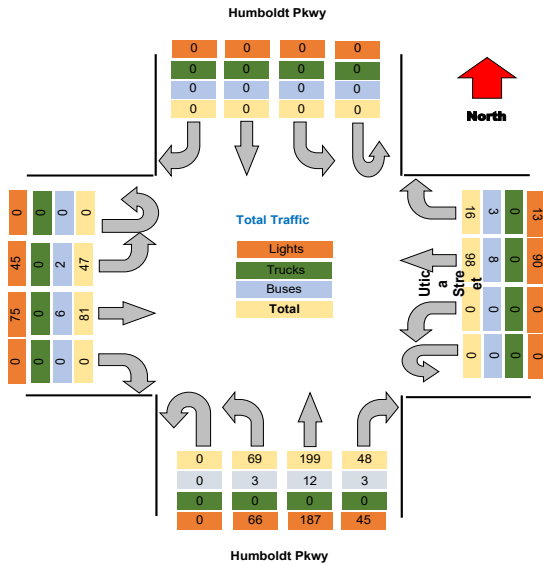

Turning Movement Peak Hour Data (PM)

4:15:00 PM

Leg Direction	Humboldt Pkwy										Utica Street										Humboldt Pkwy										Utica Street										Total
	Southbound					Westbound					Northbound					Eastbound					Northbound					Eastbound															
	Right	Thru	Left	U-Turn	App Total	Right	Thru	Left	U-Turn	App Total	Right	Thru	Left	U-Turn	App Total	Right	Thru	Left	U-Turn	App Total	Right	Thru	Left	U-Turn	App Total	Right	Thru	Left	U-Turn	App Total											
4:15:00 PM	0	0	0	0	0	6	22	0	0	28	11	67	14	0	92	0	42	34	0	76	0	0	0	0	0	0	0	0	0	0											
4:30:00 PM	0	0	0	0	0	7	20	0	0	27	24	50	22	0	96	0	31	23	0	54	0	0	0	0	0	0	0	0	0	0											
4:45:00 PM	0	0	0	0	0	7	27	0	0	34	12	41	16	0	69	0	40	29	0	69	0	0	0	0	0	0	0	0	0	0											
5:00:00 PM	0	0	0	0	0	8	22	0	0	30	17	48	24	0	89	0	41	24	0	65	0	0	0	0	0	0	0	0	0	0											
Grand Total	0	0	0	0	0	28	91	0	0	119	64	206	76	0	346	0	154	110	0	264	0	0	0	0	0	0	0	0	0	0											
% Approach	#DIV/0!	#DIV/0!	#DIV/0!	#DIV/0!	0.0%	14.2%	85.8%	0.0%	0.0%	0.0%	45.1%	41.7%	13.2%	0.0%	0.0%	0.0%	66.2%	33.8%	0.0%	0.0%	0.0%	21.1%	15.1%	0.0%	36.2%	0.0%	0.0%	0.0%	0.0%	0.0%											
% Total	0.0%	0.0%	0.0%	0.0%	0.0%	3.8%	12.5%	0.0%	0.0%	16.3%	8.8%	28.3%	10.4%	0.0%	47.5%	0.0%	21.1%	15.1%	0.0%	36.2%	0.0%	0.0%	0.0%	0.0%	0.0%	0.0%	0.0%	0.0%	0.0%	0.0%											
PHF	0.000	0.000	0.000	0.000	0.000	0.875	0.843	0.000	0.000	0.875	0.667	0.769	0.792	0.000	0.801	0.000	0.917	0.809	0.000	0.868	0.000	0.000	0.000	0.000	0.000	0.000	0.000	0.000	0.000	0.000											
Lights	0	0	0	0	0	27	86	0	0	113	62	194	75	0	331	0	147	108	0	255	0	0	0	0	0	0	0	0	0	0											
% Lights	0.0%	0.0%	0.0%	0.0%	0.0%	96.4%	94.5%	0.0%	0.0%	95.0%	96.9%	94.2%	98.7%	0.0%	95.7%	0.0%	95.5%	98.2%	0.0%	96.6%	0.0%	0.0%	0.0%	0.0%	0.0%	0.0%	0.0%	0.0%	0.0%	0.0%											
Trucks	0	0	0	0	0	0	0	0	0	0	0	0	0	0	0	0	0	0	0	0	0	0	0	0	0	0	0	0	0	0											
% Trucks	0.0%	0.0%	0.0%	0.0%	0.0%	0.0%	0.0%	0.0%	0.0%	0.0%	0.0%	0.0%	0.0%	0.0%	0.0%	0.0%	0.0%	0.0%	0.0%	0.0%	0.0%	0.0%	0.0%	0.0%	0.0%	0.0%	0.0%	0.0%	0.0%	0.0%											
Buses	0	0	0	0	0	1	5	0	0	6	2	11	1	0	14	0	6	2	0	8	0	0	0	0	0	0	0	0	0	0											
% Buses	0.0%	0.0%	0.0%	0.0%	0.0%	3.6%	5.5%	0.0%	0.0%	0.0%	3.1%	5.3%	1.3%	0.0%	0.0%	0.0%	3.9%	1.8%	0.0%	0.0%	0.0%	0.0%	0.0%	0.0%	0.0%	0.0%	0.0%	0.0%	0.0%	0.0%											
Pedestrians	0	0	0	0	5	0	0	0	0	0	0	0	0	0	5	0	0	0	0	0	0	0	0	0	0	0	0	0	0	0											
% Pedestrians	0.0%	0.0%	0.0%	0.0%	100.0%	0.0%	0.0%	0.0%	0.0%	0.0%	0.0%	0.0%	0.0%	0.0%	0.0%	0.0%	0.0%	0.0%	0.0%	0.0%	0.0%	0.0%	0.0%	0.0%	0.0%	0.0%	0.0%	0.0%	0.0%	0.0%											
Bicycles on Crosswalk	0	0	0	0	0	0	0	0	0	0	0	0	0	0	0	0	0	0	0	0	0	0	0	0	0	0	0	0	0	0											
% Bicycles on Crosswalk	0.0%	0.0%	0.0%	0.0%	0.0%	0.0%	0.0%	0.0%	0.0%	0.0%	0.0%	0.0%	0.0%	0.0%	0.0%	0.0%	0.0%	0.0%	0.0%	0.0%	0.0%	0.0%	0.0%	0.0%	0.0%	0.0%	0.0%	0.0%	0.0%	0.0%											

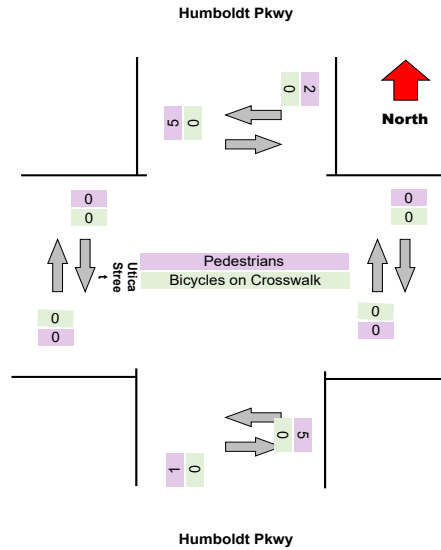
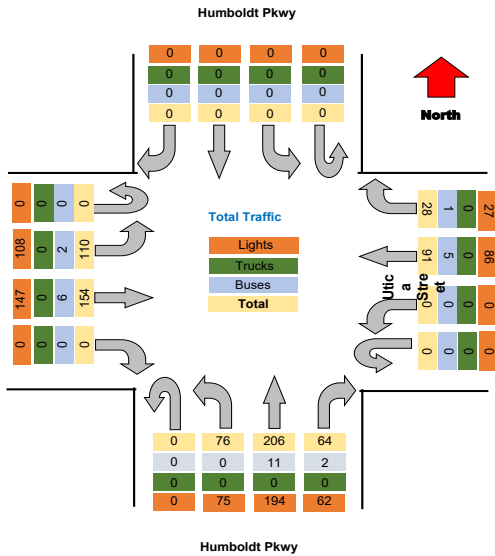

Project : VBH Malta NY
 Site : Site 4
 Location : 42.948550, -73.790036
 Survey Date : 2021-04-28, Wednesday

Turning Movement Data Plot

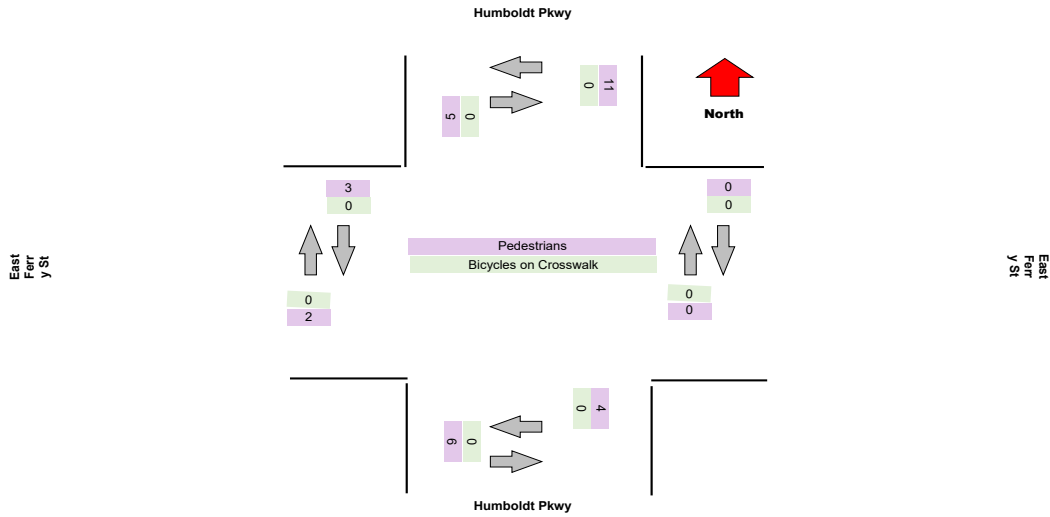
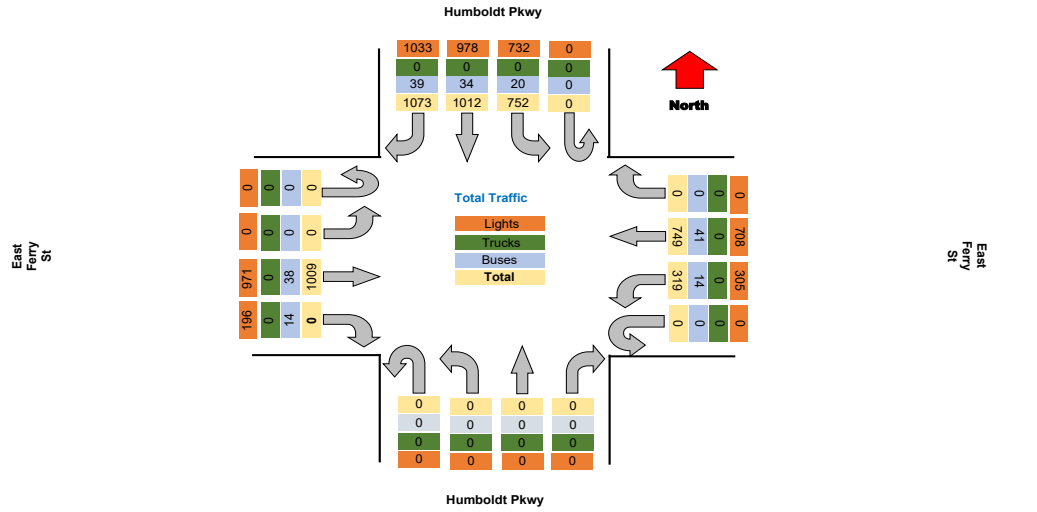

Project : VBH Malta NY
Site : Site 4
Location : 42.948550, -73.790036

TSTData.com

Survey Date : 2021-04-28, Wednesday

Turning Movement Peak Hour Data (AM)

7:30:00 AM

Leg Direction	Humboldt Pkwy					East Ferry St					Humboldt Pkwy					East Ferry St					Total							
	Right	Thru	Left	U-Turn	App Total	Right	Thru	Left	U-Turn	App Total	Right	Thru	Left	U-Turn	App Total	Right	Thru	Left	U-Turn	App Total								
7:30:00 AM	96	72	62	0	230	1	1	0	0	34	22	0	0	0	57	0	0	0	0	0	7	61	0	0	68	0	0	355
7:45:00 AM	108	60	55	0	223	1	1	0	0	31	19	0	0	0	51	0	0	0	0	0	11	61	0	0	72	0	0	346
8:00:00 AM	83	52	35	0	170	0	0	0	0	49	15	0	0	0	65	0	0	0	0	0	10	68	0	0	78	0	0	313
8:15:00 AM	68	68	45	0	181	0	0	0	0	48	31	0	0	0	79	0	0	0	0	0	14	43	0	0	57	0	0	318
Grand Total	355	252	197	0	804	3	2	0	0	152	87	0	0	0	253	0	0	0	0	0	42	233	0	0	275	0	0	1332
% Approach	44.2%	31.3%	24.5%	0.0%	0.0%	0.0%	0.0%	14.2%	85.8%	0.0%	0.0%	0.0%	0.0%	0.0%	45.1%	41.7%	13.2%	0.0%	0.0%	0.0%	0.0%	66.2%	33.8%	0.0%	0.0%	0.0%	0.0%	0.0%
% Total	26.7%	18.9%	14.8%	0.0%	60.4%	0.0%	0.0%	0.0%	12.2%	6.5%	0.0%	0.0%	0.0%	0.0%	19.0%	0.0%	0.0%	0.0%	0.0%	0.0%	3.2%	17.5%	0.0%	0.0%	20.6%	0.0%	0.0%	
PHF	0.822	0.875	0.794	0.000	0.874	0.000	0.000	0.000	0.827	0.702	0.000	0.791	0.000	0.000	0.000	0.000	0.000	0.000	0.000	0.000	0.750	0.857	0.000	0.000	0.881	0.000	0.000	
Lights	341	241	193	0	775	0	0	0	153	83	0	0	0	0	236	0	0	0	0	0	38	219	0	0	257	0	0	
% Trucks	96.1%	95.6%	98.0%	0.0%	96.4%	0.0%	0.0%	0.0%	94.4%	95.4%	0.0%	93.3%	0.0%	0.0%	0.0%	0.0%	0.0%	0.0%	0.0%	0.0%	90.5%	94.0%	0.0%	0.0%	93.5%	0.0%	0.0%	
Buses	13	11	4	0	28	0	0	0	9	4	0	0	0	0	13	0	0	0	0	0	4	14	0	0	18	0	0	
% Pedestrians	3.7%	4.4%	2.0%	0.0%	0.0%	0.0%	0.0%	0.0%	5.6%	4.6%	0.0%	0.0%	0.0%	0.0%	0.0%	0.0%	0.0%	0.0%	0.0%	0.0%	9.5%	6.0%	0.0%	0.0%	0.0%	0.0%	4.4%	
% Bicycles on Crosswalk	0.0%	0.0%	0.0%	0.0%	0.0%	100.0%	100.0%	0.0%	0.0%	0.0%	0.0%	0.0%	0.0%	0.0%	0.0%	0.0%	0.0%	0.0%	0.0%	0.0%	0.0%	0.0%	0.0%	0.0%	0.0%	0.0%	0.0%	

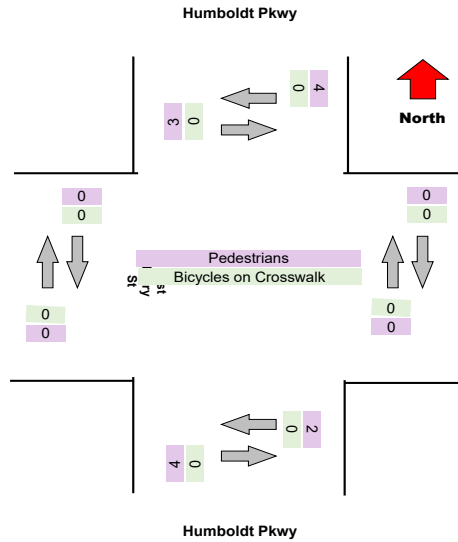
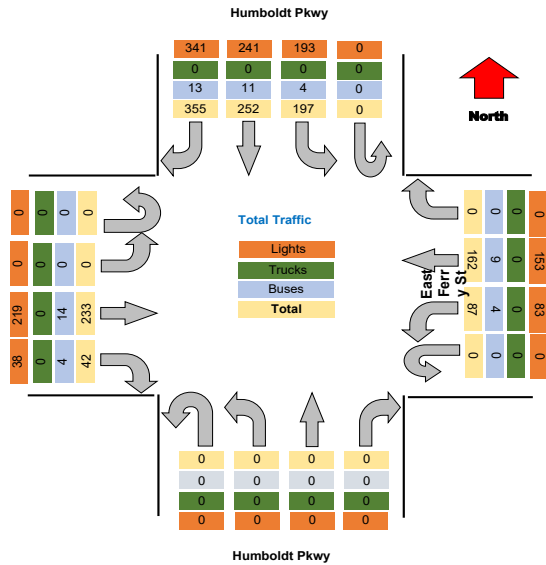

Project : VBH Malta NY
Site : Site 4
Location : 42.948550, -73.790036

TSTData.com

Survey Date : 2021-04-28, Wednesday

Turning Movement Peak Hour Data (PM)

4:15:00 PM

Leg Direction	Humboldt Pkwy										East Ferry St										Humboldt Pkwy										East Ferry St										Total
	Southbound					Westbound					Northbound					Eastbound																									
	Right	Thru	Left	U-Turn	App Total	Right	Thru	Left	U-Turn	App Total	Right	Thru	Left	U-Turn	App Total	Right	Thru	Left	U-Turn	App Total																					
4:15:00 PM	57	81	53	0	191	1	1	0	73	27	0	100	0	0	0	0	0	13	98	0	0	111	0	0	0	0	0	402													
4:30:00 PM	56	79	68	0	203	0	1	0	56	28	0	84	0	0	0	0	0	23	84	0	0	107	0	0	0	0	0	394													
4:45:00 PM	68	71	49	0	188	0	0	0	62	35	0	97	0	0	0	0	0	22	73	0	0	95	0	0	0	0	0	380													
5:00:00 PM	71	72	36	0	179	0	1	0	64	25	0	89	0	0	0	0	0	21	62	0	0	113	0	0	0	0	0	351													
Grand Total	252	303	206	0	761	1	1	0	255	115	0	370	0	0	0	0	0	79	347	0	0	426	0	0	0	0	0	1557													
% Approach	33.1%	39.6%	27.1%	0.0%	0.0%	0.0%	0.0%	0.0%	14.2%	85.8%	0.0%	0.0%	0.0%	0.0%	0.0%	0.0%	0.0%	45.1%	41.7%	13.2%	0.0%	0.0%	0.0%	66.2%	33.8%	0.0%	0.0%	0.0%	0.0%	0.0%											
% Total	16.2%	19.5%	13.2%	0.0%	48.8%	0.0%	0.0%	0.0%	0.0%	16.4%	7.4%	0.0%	23.8%	0.0%	0.0%	0.0%	0.0%	0.0%	0.0%	0.0%	0.0%	0.0%	0.0%	5.1%	22.3%	0.0%	0.0%	27.4%	0.0%	0.0%	0.0%										
PHF	0.887	0.935	0.757	0.000	0.937	0.000	0.000	0.000	0.000	0.873	0.821	0.000	0.925	0.000	0.000	0.000	0.000	0.000	0.000	0.859	0.885	0.000	0.000	0.942	0.000	0.000	0.000	0.968													
Lights	246	292	202	0	740	0	0	0	243	110	0	353	0	0	0	0	0	72	337	0	0	409	0	0	0	0	0	1502													
% Lights	97.6%	96.4%	98.1%	0.0%	97.2%	0.0%	0.0%	0.0%	95.3%	95.7%	0.0%	95.4%	0.0%	0.0%	0.0%	0.0%	0.0%	91.1%	97.1%	0.0%	0.0%	96.0%	0.0%	0.0%	0.0%	0.0%	0.0%	96.5%													
Trucks	0	0	0	0	0	0	0	0	0	0	0	0	0	0	0	0	0	0	0	0	0	0	0	0	0	0	0	0													
% Trucks	0.0%	0.0%	0.0%	0.0%	0.0%	0.0%	0.0%	0.0%	0.0%	0.0%	0.0%	0.0%	0.0%	0.0%	0.0%	0.0%	0.0%	0.0%	0.0%	0.0%	0.0%	0.0%	0.0%	0.0%	0.0%	0.0%	0.0%	0.0%													
Buses	6	11	4	0	21	0	0	0	12	5	0	17	0	0	0	0	0	7	10	0	0	17	0	0	0	0	0	55													
% Buses	2.4%	3.6%	1.9%	0.0%	0.0%	0.0%	0.0%	0.0%	4.7%	4.3%	0.0%	0.0%	0.0%	0.0%	0.0%	0.0%	0.0%	8.9%	2.9%	0.0%	0.0%	0.0%	0.0%	0.0%	0.0%	0.0%	0.0%	3.5%													
Pedestrians	0	0	0	0	0	1	3	0	0	0	0	0	0	0	0	0	0	3	0	0	0	0	0	0	0	0	0	0													
% Pedestrians	0.0%	0.0%	0.0%	0.0%	0.0%	100.0%	100.0%	0.0%	0.0%	0.0%	0.0%	0.0%	0.0%	0.0%	0.0%	0.0%	0.0%	100.0%	0.0%	0.0%	0.0%	0.0%	0.0%	0.0%	0.0%	0.0%	0.0%	0.0%													
Bicycles on Crosswalk	0	0	0	0	0	0	0	0	0	0	0	0	0	0	0	0	0	0	0	0	0	0	0	0	0	0	0	0													
% Bicycles on Crosswalk	0.0%	0.0%	0.0%	0.0%	0.0%	0.0%	0.0%	0.0%	0.0%	0.0%	0.0%	0.0%	0.0%	0.0%	0.0%	0.0%	0.0%	0.0%	0.0%	0.0%	0.0%	0.0%	0.0%	0.0%	0.0%	0.0%	0.0%	0.0%													

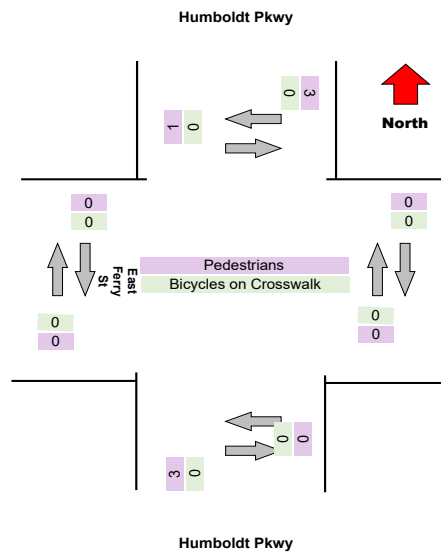
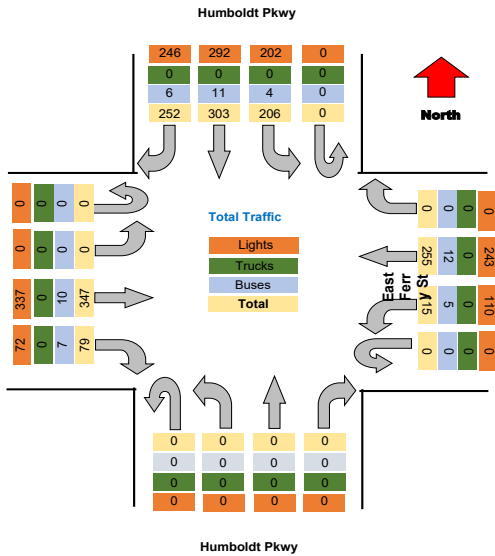

Project : VBH Malta NY
Site : Site 4
Location : 42.948550, -73.790036

TSTData.com

Survey Date : 2021-04-28, Wednesday

Project	Labella
Project Code	Labella
Site Name	8
Legs and Movements	All Processed Legs & Move
Bin Size	15 minutes
Survey Date	2021-10-27, Wednesday
Location	8
Latitude and Longitude	42.914700, -78.843693

	Start	End	PHF
Forced Peak AM	2021/10/27 07:30:00	2021/10/27 08:30:00	0.89
Forced Peak PM	2021/10/27 16:30:00	2021/10/27 17:30:00	0.95
AM Peak	2021/10/27 07:30:00	2021/10/27 08:30:00	0.89
PM Peak	2021/10/27 16:15:00	2021/10/27 17:15:00	0.89

Turning Movement Data

Leg Direction	Humboldt Pkwy								East Ferry St								Humboldt Pkwy								East Ferry St								Total
	Southbound				Westbound				Northbound				Eastbound				Westbound				Northbound												
Start Time	Right	Thru	Left	U-Turn	App Total	Peds CV	Peds CCV	Right	Thru	Left	U-Turn	App Total	Peds CV	Peds CCV	Right	Thru	Left	U-Turn	App Total	Peds CV	Peds CCV	Right	Thru	Left	U-Turn	App Total	Peds CV	Peds CCV					
6:30:00 AM	48	31	22	0	101	0	0	0	18	6	0	24	0	0	0	0	0	0	0	0	0	0	6	23	0	0	29	0	0	154			
6:45:00 AM	37	42	29	0	108	0	0	0	24	6	0	30	0	0	0	0	0	0	0	0	0	0	3	25	0	0	28	0	0	166			
Hourly Total	85	73	51	0	209	0	0	0	42	12	0	54	0	0	0	0	0	0	0	0	0	9	48	0	0	57	0	0	320				
7:00:00 AM	31	22	29	0	82	1	0	0	28	11	0	39	0	0	0	0	0	0	0	0	0	0	8	34	0	0	42	0	0	163			
7:15:00 AM	95	49	53	0	197	1	0	0	37	13	0	50	0	0	0	0	0	0	0	0	0	0	8	41	0	0	49	1	1	296			
7:30:00 AM	83	71	49	0	203	0	0	0	38	11	0	49	0	0	0	0	0	0	0	0	0	1	11	66	0	0	77	0	0	329			
7:45:00 AM	126	75	53	0	254	1	0	0	47	22	0	69	0	0	0	0	0	0	0	0	0	0	9	67	0	0	76	0	0	399			
Hourly Total	335	217	184	0	736	3	0	0	150	57	0	207	0	0	0	0	0	0	0	0	0	1	36	208	0	0	244	1	1	1187			
8:00:00 AM	107	69	38	0	214	0	0	0	49	23	0	72	0	0	0	0	0	0	0	0	0	0	10	70	0	0	80	0	0	366			
8:15:00 AM	74	67	38	0	179	0	0	0	50	25	0	75	0	0	0	0	0	0	0	0	0	0	13	58	0	0	71	0	0	325			
Hourly Total	181	136	76	0	393	0	0	0	99	48	0	147	0	0	0	0	0	0	0	0	0	0	23	128	0	0	151	0	0	691			
4:00:00 PM	62	83	67	0	212	1	0	0	53	21	0	74	0	0	0	0	0	0	0	0	0	0	22	107	0	0	129	1	1	415			
4:15:00 PM	82	84	83	0	249	0	0	0	79	20	0	99	0	0	0	0	0	0	0	0	0	3	4	16	109	0	0	125	0	4	473		
4:30:00 PM	69	77	59	0	205	1	0	0	66	33	0	99	0	0	0	0	0	0	0	0	0	0	18	96	0	0	116	1	0	420			
4:45:00 PM	92	73	63	0	228	0	0	0	69	18	0	86	0	0	0	0	0	0	0	0	0	1	13	77	0	0	90	0	1	404			
Hourly Total	305	317	272	0	894	2	0	0	268	92	0	358	0	0	0	0	0	0	0	0	0	3	5	69	391	0	0	480	2	6	1712		
5:00:00 PM	71	72	44	0	187	0	0	0	68	28	0	94	0	0	0	0	0	0	0	0	0	0	12	87	0	0	99	0	0	380			
5:15:00 PM	71	85	47	0	203	2	3	0	57	22	0	79	0	0	0	0	0	0	0	0	0	2	0	11	92	0	0	103	2	1	385		
5:30:00 PM	74	75	53	0	202	3	2	0	52	18	0	70	0	0	0	0	0	0	0	0	0	1	0	10	61	0	0	71	0	0	343		
5:45:00 PM	78	64	62	0	204	0	0	0	58	23	0	81	0	0	0	0	0	0	0	0	0	0	13	76	0	0	89	0	0	374			
Hourly Total	294	296	206	0	796	5	5	0	233	91	0	324	0	0	0	0	0	0	0	0	0	6	0	46	316	0	0	362	2	1	1482		
Grand Total	1200	1039	789	0	3028	10	7	0	790	300	0	1090	0	0	0	0	0	0	0	0	0	9	6	183	1091	0	0	1274	5	10	5392		
% Approach	39.6%	34.3%	26.1%	0.0%	0.0%	0.0%	0.0%	0.0%	72.5%	27.5%	0.0%	0.0%	0.0%	0.0%	0.0%	0.0%	0.0%	0.0%	0.0%	0.0%	0.0%	0.0%	0.0%	14.4%	85.6%	0.0%	0.0%	0.0%	0.0%	0.0%	0.0%		
% Total	22.3%	19.3%	14.6%	0.0%	56.2%	0.0%	0.0%	0.0%	14.7%	5.6%	0.0%	20.2%	0.0%	0.0%	0.0%	0.0%	0.0%	0.0%	0.0%	0.0%	0.0%	0.0%	0.0%	3.4%	20.2%	0.0%	0.0%	23.6%	0.0%	0.0%	0.0%		
Lights	1175	998	763	0	2936	0	0	0	744	286	0	1030	0	0	0	0	0	0	0	0	0	0	0	171	1045	0	0	1216	0	0	5182		
% Lights	97.9%	96.1%	95.7%	0.0%	97.0%	0.0%	0.0%	0.0%	94.2%	95.3%	0.0%	94.0%	0.0%	0.0%	0.0%	0.0%	0.0%	0.0%	0.0%	0.0%	0.0%	0.0%	0.0%	93.4%	95.8%	0.0%	0.0%	95.4%	0.0%	0.0%	96.1%		
Trucks	0	0	1	0	1	0	0	0	1	0	0	1	0	0	0	0	0	0	0	0	0	0	0	0	1	0	0	1	0	0	3		
% Trucks	0.0%	0.0%	0.1%	0.0%	0.0%	0.0%	0.0%	0.0%	0.1%	0.0%	0.0%	0.1%	0.0%	0.0%	0.0%	0.0%	0.0%	0.0%	0.0%	0.0%	0.0%	0.0%	0.0%	0.0%	0.1%	0.0%	0.0%	0.1%	0.0%	0.0%	0.1%		
Buses	25	40	25	0	90	0	0	0	43	13	0	56	0	0	0	0	0	0	0	0	0	0	0	12	45	0	0	57	0	0	203		
% Buses	2.1%	3.8%	3.2%	0.0%	0.0%	0.0%	0.0%	0.0%	5.4%	4.3%	0.0%	0.0%	0.0%	0.0%	0.0%	0.0%	0.0%	0.0%	0.0%	0.0%	0.0%	0.0%	0.0%	6.6%	4.1%	0.0%	0.0%	0.0%	0.0%	0.0%	3.8%		
Pedestrians	0	0	0	0	0	9	6	0	0	0	0	0	0	0	0	0	0	0	0	0	0	0	9	5	0	0	0	4	9	0			
% Pedestrians	0.0%	0.0%	0.0%	0.0%	0.0%	89.0%	85.7%	0.0%	0.0%	0.0%	0.0%	0.0%	0.0%	0.0%	0.0%	0.0%	0.0%	0.0%	0.0%	0.0%	0.0%	0.0%	100.0%	83.3%	0.0%	0.0%	0.0%	0.0%	80.0%	80.0%	0.0%		
Bicycles on Crosswalk	0	0	0	0	0	1	1	0	0	0	0	0	0	0	0	0	0	0	0	0	0	0	0	0	0	0	0	1	1	0			
% Bicycles on Crosswalk	0.0%	0.0%	0.0%	0.0%	0.0%	10.0%	14.3%	0.0%	0.0%	0.0%	0.0%	0.0%	0.0%	0.0%	0.0%	0.0%	0.0%	0.0%	0.0%	0.0%	0.0%	0.0%	0.0%	0.0%	0.0%	0.0%	0.0%	0.0%	20.0%	10.0%	0.0%		

Project : VBH Malta NY
 Site : Site 4
 Location : 42.948550, -73.790036
 Survey Date : 2021-04-28, Wednesday

Turning Movement Data Plot

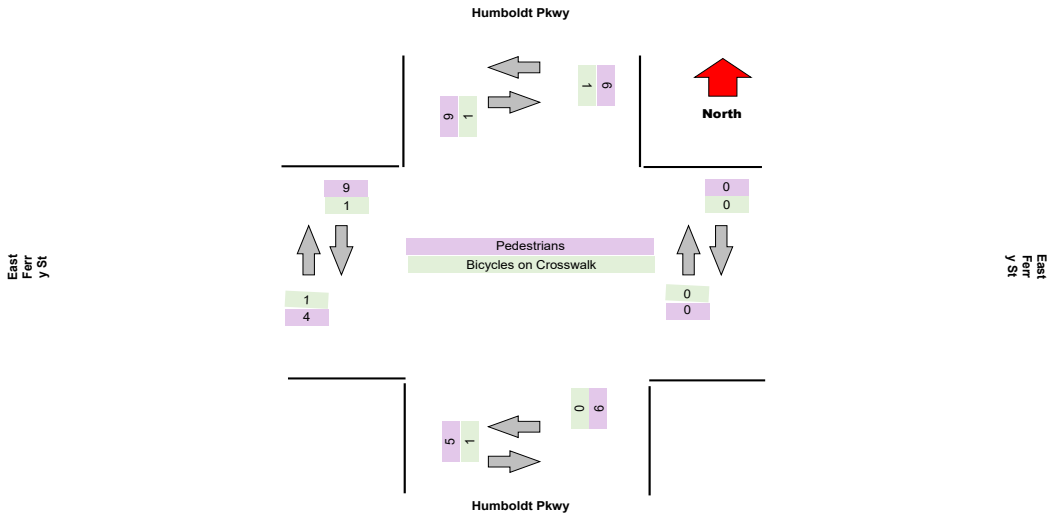
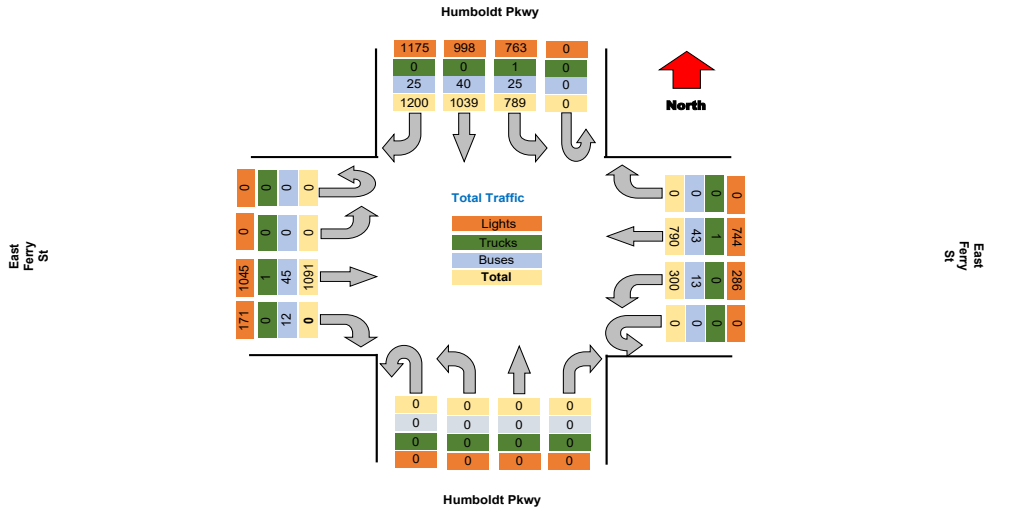

Turning Movement Peak Hour Data (AM)

7:30:00 AM

Leg Direction	Humboldt Pkwy								East Ferry St								Humboldt Pkwy								East Ferry St								Total
	Southbound				Westbound				Northbound				Eastbound				Northbound				Eastbound												
Start Time	Right	Thru	Left	U-Turn	App Total	Peds CW	Peds CCW	Right	Thru	Left	U-Turn	App Total	Peds CW	Peds CCW	Right	Thru	Left	U-Turn	App Total	Peds CW	Peds CCW	Right	Thru	Left	U-Turn	App Total	Peds CW	Peds CCW					
7:30:00 AM	83	71	49	0	203	0	0	0	38	11	0	49	0	0	0	0	0	0	0	0	0	0	0	0	0	0	0	0	0	0	0	0	329
7:45:00 AM	126	75	53	0	254	1	0	0	47	22	0	69	0	0	0	0	0	0	0	0	0	0	0	0	0	0	0	0	0	0	0	399	
8:00:00 AM	107	69	38	0	214	0	0	0	49	23	0	72	0	0	0	0	0	0	0	0	0	0	0	0	0	0	0	0	0	0	0	366	
8:15:00 AM	74	67	36	0	177	0	0	0	50	25	0	75	0	0	0	0	0	0	0	0	0	0	0	0	0	0	0	0	0	0	0	325	
Grand Total	390	282	178	0	850	1	0	0	184	81	0	265	0	0	0	0	0	0	0	0	0	0	0	0	0	0	0	0	0	0	1419		
% Approach	45.9%	33.2%	20.9%	0.0%	0.0%	0.0%	0.0%	14.2%	85.8%	0.0%	0.0%	0.0%	0.0%	0.0%	45.1%	41.7%	13.2%	0.0%	0.0%	0.0%	0.0%	0.0%	0.0%	0.0%	66.2%	33.8%	0.0%	0.0%	0.0%	0.0%	0.0%		
% Total	27.5%	19.9%	12.5%	0.0%	59.9%	0.0%	0.0%	0.0%	13.0%	5.7%	0.0%	18.7%	0.0%	0.0%	0.0%	0.0%	0.0%	0.0%	0.0%	0.0%	0.0%	0.0%	0.0%	0.0%	3.0%	16.4%	0.0%	0.0%	21.4%	0.0%	0.0%		
PHF	0.774	0.940	0.840	0.000	0.837	0.000	0.000	0.000	0.920	0.810	0.000	0.883	0.000	0.000	0.000	0.000	0.000	0.000	0.000	0.827	0.932	0.000	0.000	0.950	0.000	0.000	0.950	0.000	0.000	0.889	0.000	0.000	
Lights	385	266	175	0	826	0	0	0	172	76	0	248	0	0	0	0	0	0	0	0	0	0	0	0	0	40	245	0	0	285	0	0	1369
% Lights	88.7%	84.3%	88.3%	0.0%	97.2%	0.0%	0.0%	0.0%	93.5%	93.8%	0.0%	93.6%	0.0%	0.0%	0.0%	0.0%	0.0%	0.0%	0.0%	0.0%	0.0%	0.0%	0.0%	0.0%	0.0%	93.0%	93.9%	0.0%	0.0%	93.8%	0.0%	0.0%	95.8%
Trucks	0	0	0	0	0	0	0	0	1	0	0	1	0	0	0	0	0	0	0	0	0	0	0	0	0	0	0	0	0	0	0	1	
% Trucks	0.0%	0.0%	0.0%	0.0%	0.0%	0.0%	0.0%	0.0%	0.5%	0.0%	0.0%	0.4%	0.0%	0.0%	0.0%	0.0%	0.0%	0.0%	0.0%	0.0%	0.0%	0.0%	0.0%	0.0%	0.0%	0.0%	0.0%	0.0%	0.0%	0.0%	0.1%	0.0%	
Buses	5	16	3	0	24	0	0	0	11	5	0	16	0	0	0	0	0	0	0	0	0	0	0	0	0	3	16	0	0	19	0	0	59
% Buses	1.3%	5.7%	1.7%	0.0%	0.0%	0.0%	0.0%	0.0%	6.0%	6.2%	0.0%	0.0%	0.0%	0.0%	0.0%	0.0%	0.0%	0.0%	0.0%	0.0%	0.0%	0.0%	0.0%	0.0%	0.0%	7.0%	6.1%	0.0%	0.0%	0.0%	0.0%	4.2%	
Pedestrians	0	0	0	0	0	1	0	0	0	0	0	0	0	0	0	0	0	0	0	0	1	0	0	0	0	0	0	0	0	0	0	0	
% Pedestrians	0.0%	0.0%	0.0%	0.0%	0.0%	100.0%	0.0%	0.0%	0.0%	0.0%	0.0%	0.0%	0.0%	0.0%	0.0%	0.0%	0.0%	0.0%	0.0%	0.0%	100.0%	0.0%	0.0%	0.0%	0.0%	0.0%	0.0%	0.0%	0.0%	0.0%	0.0%	0.0%	
Bicycles on Crosswalk	0	0	0	0	0	0	0	0	0	0	0	0	0	0	0	0	0	0	0	0	0	0	0	0	0	0	0	0	0	0	0	0	
% Bicycles on Crosswalk	0.0%	0.0%	0.0%	0.0%	0.0%	0.0%	0.0%	0.0%	0.0%	0.0%	0.0%	0.0%	0.0%	0.0%	0.0%	0.0%	0.0%	0.0%	0.0%	0.0%	0.0%	0.0%	0.0%	0.0%	0.0%	0.0%	0.0%	0.0%	0.0%	0.0%	0.0%	0.0%	

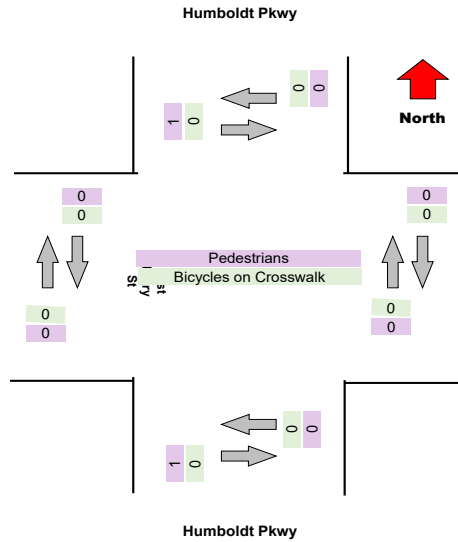
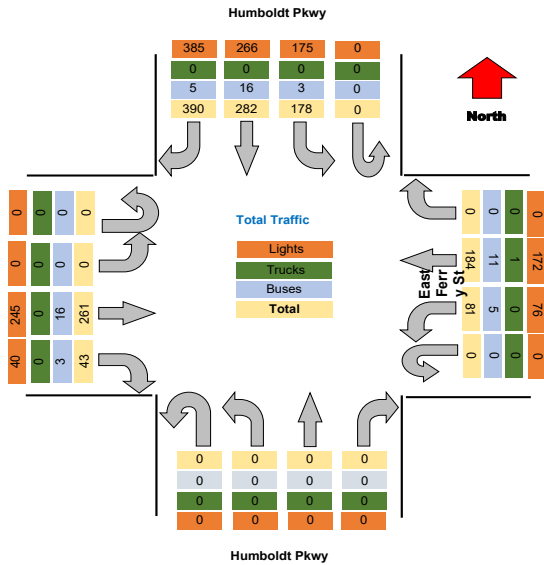

Turning Movement Peak Hour Data (PM)

4:15:00 PM

Leg Direction	Humboldt Pkwy					East Ferry St					Humboldt Pkwy					East Ferry St					Total									
	Southbound					Westbound					Northbound					Eastbound														
Start Time	Right	Thru	Left	U-Turn	App Total	Peds CW	Peds CCW	Right	Thru	Left	U-Turn	App Total	Peds CW	Peds CCW	Right	Thru	Left	U-Turn	App Total	Peds CW	Peds CCW	Total								
4:15:00 PM	82	84	83	0	249	0	0	0	79	20	0	99	0	0	0	0	0	0	0	3	4	16	109	0	0	125	0	4	473	
4:30:00 PM	69	77	59	0	205	1	0	0	66	33	0	99	0	0	0	0	0	0	0	0	0	18	98	0	0	116	1	0	420	
4:45:00 PM	92	73	63	0	228	0	2	0	68	18	0	86	0	0	0	0	0	0	0	0	1	13	77	0	0	90	0	1	404	
5:00:00 PM	71	72	44	0	187	0	0	0	65	28	0	94	0	0	0	0	0	0	0	0	0	12	87	0	0	99	0	0	380	
Grand Total	314	306	249	0	869	1	2	0	279	99	0	378	0	0	0	0	0	0	0	3	5	59	371	0	0	430	1	5	1677	
% Approach	36.1%	35.2%	28.7%	0.0%	0.0%	0.0%	0.0%	14.2%	85.6%	0.0%	0.0%	0.0%	0.0%	0.0%	45.1%	41.7%	13.2%	0.0%	0.0%	0.0%	0.0%	0.0%	0.0%	66.2%	33.8%	0.0%	0.0%	0.0%	0.0%	0.0%
% Total	18.7%	18.2%	14.8%	0.0%	51.8%	0.0%	0.0%	0.0%	16.6%	5.9%	0.0%	22.5%	0.0%	0.0%	0.0%	0.0%	0.0%	0.0%	0.0%	0.0%	0.0%	0.0%	3.5%	22.1%	0.0%	0.0%	25.6%	0.0%	0.0%	
PHF	0.853	0.911	0.750	0.000	0.872	0.000	0.000	0.000	0.883	0.750	0.000	0.955	0.000	0.000	0.000	0.000	0.000	0.000	0.000	0.000	0.000	0.000	0.000	0.819	0.851	0.000	0.000	0.860	0.000	0.000
Lights	310	296	239	0	845	0	0	0	264	96	0	360	0	0	0	0	0	0	0	0	0	54	363	0	0	417	0	0	1622	
% Lights	88.7%	96.7%	96.0%	0.0%	97.2%	0.0%	0.0%	0.0%	94.6%	97.0%	0.0%	95.2%	0.0%	0.0%	0.0%	0.0%	0.0%	0.0%	0.0%	0.0%	0.0%	91.5%	97.8%	0.0%	0.0%	97.0%	0.0%	0.0%	96.7%	
Trucks	0	0	0	0	0	0	0	0	0	0	0	0	0	0	0	0	0	0	0	0	0	0	0	0	0	0	0	0	0	
% Trucks	0.0%	0.0%	0.0%	0.0%	0.0%	0.0%	0.0%	0.0%	0.0%	0.0%	0.0%	0.0%	0.0%	0.0%	0.0%	0.0%	0.0%	0.0%	0.0%	0.0%	0.0%	0.0%	0.0%	0.0%	0.0%	0.0%	0.0%	0.0%	0.0%	
Buses	4	9	10	0	23	0	0	0	13	3	0	16	0	0	0	0	0	0	0	0	0	5	8	0	0	13	0	0	52	
% Buses	1.3%	2.9%	4.0%	0.0%	0.0%	0.0%	0.0%	0.0%	4.7%	3.0%	0.0%	0.0%	0.0%	0.0%	0.0%	0.0%	0.0%	0.0%	0.0%	0.0%	0.0%	8.5%	2.2%	0.0%	0.0%	0.0%	0.0%	0.0%	3.1%	
Pedestrians	0	0	0	0	0	1	0	0	0	0	0	0	0	0	6	4	0	0	0	0	0	0	0	0	0	0	1	4	0	
% Pedestrians	0.0%	0.0%	0.0%	0.0%	0.0%	0.0%	50.0%	0.0%	0.0%	0.0%	0.0%	0.0%	0.0%	0.0%	100.0%	80.0%	0.0%	0.0%	0.0%	0.0%	0.0%	0.0%	0.0%	0.0%	0.0%	0.0%	100.0%	80.0%	0.0%	
Bicycles on Crosswalk	0	0	0	0	1	1	0	0	0	0	0	0	0	0	1	0	0	0	0	0	0	1	0	0	0	0	1	0		
% Bicycles on Crosswalk	0.0%	0.0%	0.0%	0.0%	0.0%	100.0%	50.0%	0.0%	0.0%	0.0%	0.0%	0.0%	0.0%	0.0%	0.0%	0.0%	0.0%	0.0%	0.0%	0.0%	0.0%	0.0%	0.0%	0.0%	0.0%	0.0%	0.0%	20.0%	0.0%	

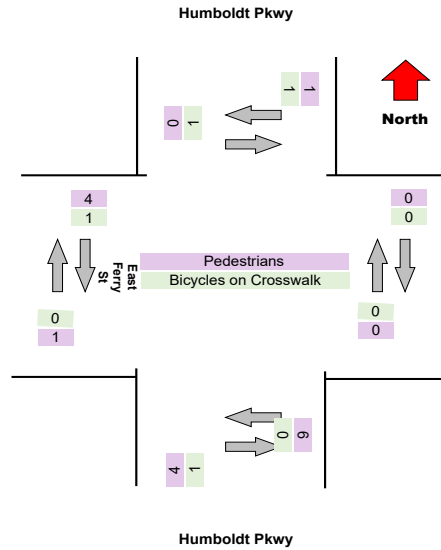
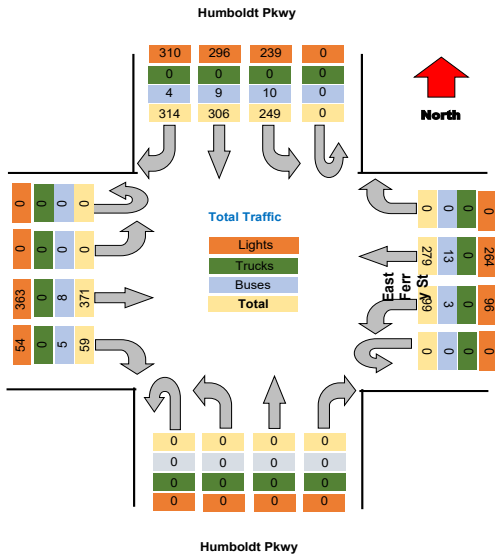

Project : VBH Malta NY
Site : Site 4
Location : 42.948550, -73.790036

TSTData.com

Survey Date : 2021-04-28, Wednesday

Project	Labella
Project Code	Labella
Site Name	8
Legs and Movements	All Processed Legs & Move
Bin Size	15 minutes
Survey Date	2021-10-28, Thursday
Location	8
Latitude and Longitude	42.914700, -78.843693

	Start	End	PHF
Forced Peak AM	2021/10/28 07:30:00	2021/10/28 08:30:00	0.89
Forced Peak PM	2021/10/28 16:30:00	2021/10/28 17:30:00	0.98
AM Peak	2021/10/28 07:30:00	2021/10/28 08:30:00	0.89
PM Peak	2021/10/28 16:15:00	2021/10/28 17:15:00	0.92

Turning Movement Data

Leg Direction	Humboldt Pkwy										East Ferry St										Total											
	Southbound					Westbound					Northbound					Eastbound																
	Right	Thru	Left	U-Turn	App Total	Peds CV	Peds CCV	Right	Thru	Left	U-Turn	App Total	Peds CV	Peds CCV	Right	Thru	Left	U-Turn	App Total	Peds CV		Peds CCV										
Start Time																																
6:30:00 AM	31	27	23	0	81	0	0	0	15	6	0	21	0	0	0	0	0	0	0	0	0	0	6	34	0	0	40	0	0	142		
6:45:00 AM	48	28	33	0	119	0	0	0	25	13	0	38	0	0	0	0	0	0	0	0	0	0	7	18	0	0	25	0	0	182		
Hourly Total	79	55	56	0	209	0	0	0	40	19	0	59	0	0	0	0	0	0	0	0	0	0	13	52	0	0	65	0	1	324		
7:00:00 AM	36	24	32	0	92	0	0	0	23	12	0	35	0	0	0	0	0	0	0	0	0	0	3	32	0	0	35	0	0	162		
7:15:00 AM	58	48	34	0	140	1	0	0	25	11	0	36	0	0	0	0	0	0	0	0	0	0	6	32	0	0	38	1	1	214		
7:30:00 AM	93	69	57	0	219	0	0	0	35	15	0	50	0	0	0	0	0	0	0	0	0	0	14	57	0	0	71	2	0	340		
7:45:00 AM	102	94	53	0	249	0	1	0	41	27	0	69	0	0	0	0	0	0	0	0	0	0	11	73	0	0	84	0	0	402		
Hourly Total	289	235	178	0	709	1	1	0	124	65	0	190	0	0	0	0	0	0	0	0	0	0	34	194	0	0	228	3	1	1118		
8:00:00 AM	100	75	49	0	224	0	0	0	37	20	0	57	0	0	0	0	0	0	0	0	0	0	10	73	0	0	83	0	0	364		
8:15:00 AM	79	71	50	0	209	1	0	0	46	25	0	71	0	0	0	0	0	0	0	0	0	0	11	43	0	0	54	0	0	325		
Hourly Total	179	146	99	0	424	1	0	0	83	45	0	128	0	0	0	0	0	0	0	0	0	0	21	116	0	0	137	0	0	689		
4:00:00 PM	68	85	56	0	209	2	0	0	88	34	0	122	0	0	0	0	0	0	0	0	0	0	19	115	0	0	134	0	0	465		
4:15:00 PM	86	95	73	0	254	0	0	0	69	36	0	105	0	0	0	0	0	0	0	0	0	0	18	92	0	0	110	0	1	469		
4:30:00 PM	86	85	61	0	232	0	1	0	50	35	0	85	0	0	0	0	0	0	0	0	0	0	17	82	0	0	99	0	0	416		
4:45:00 PM	77	79	61	0	217	0	1	0	75	23	0	98	0	0	0	0	0	0	0	0	0	0	17	89	0	0	106	0	0	421		
Hourly Total	317	344	251	0	912	2	2	0	282	128	0	410	0	0	0	0	0	0	0	0	0	0	71	378	0	0	449	0	1	1771		
5:00:00 PM	79	92	58	0	229	0	0	0	56	20	0	76	0	0	0	0	0	0	0	0	0	0	12	105	0	0	117	0	1	422		
5:15:00 PM	73	79	57	0	209	0	0	0	56	18	0	74	0	0	0	0	0	0	0	0	0	0	11	94	0	0	105	0	0	388		
5:30:00 PM	81	85	65	0	231	0	1	0	58	23	0	81	0	0	0	0	0	0	0	0	0	0	12	92	0	0	104	1	1	416		
5:45:00 PM	86	82	49	0	217	0	1	0	64	26	0	90	0	0	0	0	0	0	0	0	0	0	16	86	0	0	82	1	1	389		
Hourly Total	319	338	229	0	886	0	2	0	234	87	0	321	0	0	0	0	0	0	0	0	0	0	51	357	0	0	408	2	3	1615		
Grand Total	1183	1128	811	0	3122	4	6	0	763	344	0	1108	0	0	0	0	0	0	0	0	0	0	6	6	190	1097	0	0	1287	5	6	5517
% Approach	37.9%	36.1%	26.0%	0.0%	0.0%	0.0%	0.0%	0.0%	68.9%	31.0%	0.0%	0.0%	0.0%	0.0%	0.0%	0.0%	0.0%	0.0%	0.0%	0.0%	0.0%	0.0%	0.0%	0.0%	0.0%	0.0%	0.0%	0.0%	0.0%	0.0%	0.0%	
% Total	21.4%	20.4%	14.7%	0.0%	56.6%	0.0%	0.0%	0.0%	13.8%	6.2%	0.0%	20.1%	0.0%	0.0%	0.0%	0.0%	0.0%	0.0%	0.0%	0.0%	0.0%	0.0%	0.0%	0.0%	0.0%	0.0%	0.0%	0.0%	0.0%	0.0%	0.0%	
Lights	1151	1089	785	0	3025	0	0	0	723	334	0	1057	0	0	0	0	0	0	0	0	0	0	0	179	1059	0	0	1238	0	0	5320	
% Lights	97.3%	96.5%	96.8%	0.0%	96.9%	0.0%	0.0%	0.0%	94.6%	97.1%	0.0%	95.4%	0.0%	0.0%	0.0%	0.0%	0.0%	0.0%	0.0%	0.0%	0.0%	0.0%	0.0%	0.0%	94.2%	96.5%	0.0%	0.0%	96.2%	0.0%	0.0%	96.4%
Trucks	0	1	1	0	2	0	0	0	2	0	0	2	0	0	0	0	0	0	0	0	0	0	0	0	0	0	0	0	0	0	4	
% Trucks	0.0%	0.1%	0.1%	0.0%	0.1%	0.0%	0.0%	0.0%	0.3%	0.2%	0.0%	0.2%	0.0%	0.0%	0.0%	0.0%	0.0%	0.0%	0.0%	0.0%	0.0%	0.0%	0.0%	0.0%	0.0%	0.0%	0.0%	0.0%	0.0%	0.0%	0.1%	
Buses	30	37	25	0	92	0	0	0	38	10	0	48	0	0	0	0	0	0	0	0	0	0	0	11	34	0	0	45	0	0	165	
% Buses	2.5%	3.3%	3.1%	0.0%	0.0%	0.0%	0.0%	0.0%	5.0%	2.9%	0.0%	0.0%	0.0%	0.0%	0.0%	0.0%	0.0%	0.0%	0.0%	0.0%	0.0%	0.0%	0.0%	5.8%	3.1%	0.0%	0.0%	0.0%	0.0%	0.0%	3.4%	
Pedestrians	0	0	0	0	0	4	4	0	0	0	0	0	0	0	0	0	0	0	0	0	0	0	6	7	0	0	0	4	4	0		
% Pedestrians	0.0%	0.0%	0.0%	0.0%	0.0%	100.0%	80.0%	0.0%	0.0%	0.0%	0.0%	0.0%	0.0%	0.0%	0.0%	0.0%	0.0%	0.0%	0.0%	0.0%	0.0%	0.0%	100.0%	87.5%	0.0%	0.0%	0.0%	0.0%	80.0%	66.7%	0.0%	
Bicycles on Crosswalk	0	0	0	0	0	0	1	0	0	0	0	0	0	0	0	0	0	0	0	0	0	0	0	0	0	0	0	1	2	0		
% Bicycles on Crosswalk	0.0%	0.0%	0.0%	0.0%	0.0%	0.0%	20.0%	0.0%	0.0%	0.0%	0.0%	0.0%	0.0%	0.0%	0.0%	0.0%	0.0%	0.0%	0.0%	0.0%	0.0%	0.0%	0.0%	0.0%	0.0%	0.0%	0.0%	0.0%	20.0%	33.3%	0.0%	

Project : VBH Malta NY
 Site : Site 4
 Location : 42.948550, -73.790036
 Survey Date : 2021-04-28, Wednesday

Turning Movement Data Plot

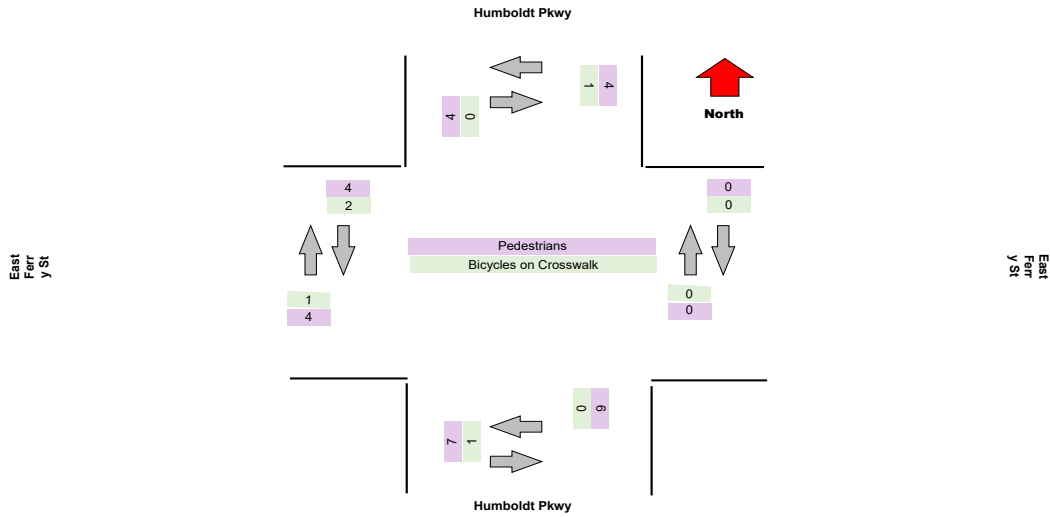
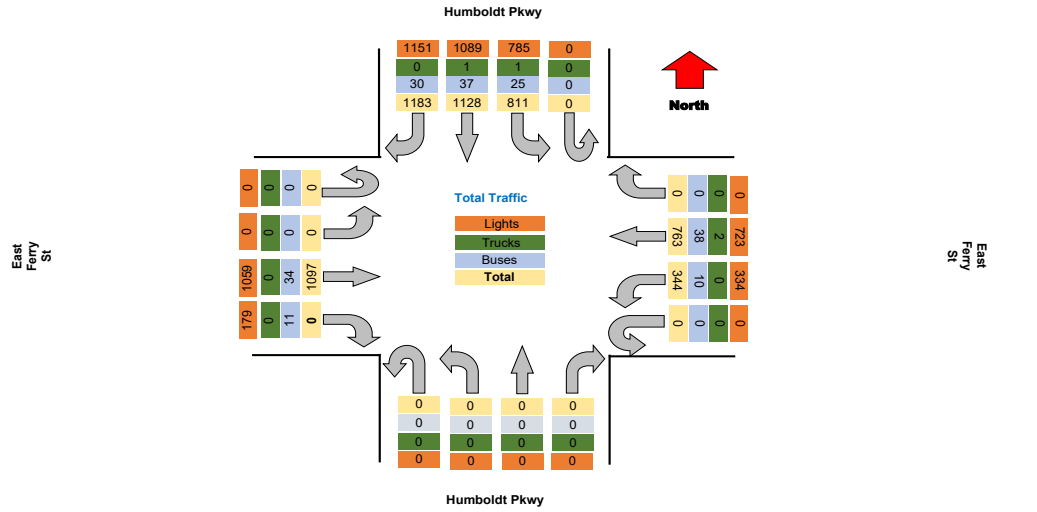

Turning Movement Peak Hour Data (AM)

7:30:00 AM

Leg Direction	Humboldt Pkwy								East Ferry St								Humboldt Pkwy								East Ferry St								Total
	Southbound				Northbound				Westbound				Eastbound				Northbound				Eastbound												
Start Time	Right	Thru	Left	U-Turn	App Total	Peds CW	Peds CCW	Right	Thru	Left	U-Turn	App Total	Peds CW	Peds CCW	Right	Thru	Left	U-Turn	App Total	Peds CW	Peds CCW	Right	Thru	Left	U-Turn	App Total	Peds CW	Peds CCW					
7:30:00 AM	93	69	57	0	219	0	0	0	35	15	0	50	0	0	0	0	0	0	0	1	2	14	57	0	0	71	2	0	340				
7:45:00 AM	102	94	53	0	249	0	1	0	41	27	0	69	0	0	0	0	0	0	0	0	0	11	73	0	0	84	0	0	402				
8:00:00 AM	100	75	49	0	224	0	0	0	37	20	0	57	0	0	0	0	0	0	0	0	0	10	73	0	0	83	0	0	364				
8:15:00 AM	79	71	50	0	200	1	0	0	46	25	0	71	0	0	0	0	0	0	0	0	0	11	43	0	0	54	0	0	325				
Grand Total	374	309	209	0	892	1	0	0	159	87	0	247	0	0	0	0	0	0	0	1	2	46	246	0	0	292	2	0	1431				
% Approach	41.9%	34.6%	23.4%	0.0%	0.0%	0.0%	0.0%	14.2%	85.8%	0.0%	0.0%	0.0%	0.0%	0.0%	45.1%	41.7%	13.2%	0.0%	0.0%	0.0%	0.0%	0.0%	66.2%	33.8%	0.0%	0.0%	0.0%	0.0%	0.0%				
% Total	26.1%	21.6%	14.6%	0.0%	62.3%	0.0%	0.0%	0.0%	11.1%	6.1%	0.0%	17.3%	0.0%	0.0%	0.0%	0.0%	0.0%	0.0%	0.0%	0.0%	0.0%	3.2%	17.2%	0.0%	0.0%	20.4%	0.0%	0.0%	3.8%				
PHF	0.917	0.822	0.917	0.000	0.896	0.000	0.000	0.000	0.864	0.806	0.000	0.870	0.000	0.000	0.000	0.000	0.000	0.000	0.000	0.000	0.000	0.821	0.842	0.000	0.000	0.869	0.000	0.000	0.890				
Lights	362	296	206	0	864	0	0	0	149	82	0	231	0	0	0	0	0	0	0	0	0	43	235	0	0	278	0	0	1373				
% Lights	96.8%	95.8%	98.6%	0.0%	96.9%	0.0%	0.0%	0.0%	93.7%	94.3%	0.0%	93.5%	0.0%	0.0%	0.0%	0.0%	0.0%	0.0%	0.0%	0.0%	0.0%	93.5%	95.5%	0.0%	0.0%	95.2%	0.0%	0.0%	95.9%				
Trucks	0	1	0	0	1	0	0	0	1	0	0	1	0	0	0	0	0	0	0	0	0	0	0	0	0	0	0	0	2				
% Trucks	0.0%	0.3%	0.0%	0.0%	0.1%	0.0%	0.0%	0.0%	0.6%	0.0%	0.0%	0.4%	0.0%	0.0%	0.0%	0.0%	0.0%	0.0%	0.0%	0.0%	0.0%	0.0%	0.0%	0.0%	0.0%	0.0%	0.0%	0.1%					
Buses	12	12	3	0	27	0	0	0	9	5	0	14	0	0	0	0	0	0	0	0	0	3	11	0	0	14	0	0	56				
% Buses	3.2%	3.9%	1.4%	0.0%	0.0%	0.0%	0.0%	0.0%	5.7%	5.7%	0.0%	0.0%	0.0%	0.0%	0.0%	0.0%	0.0%	0.0%	0.0%	0.0%	0.0%	6.5%	4.5%	0.0%	0.0%	0.0%	0.0%	0.0%	3.8%				
Pedestrians	0	0	0	0	0	1	1	0	0	0	0	0	0	0	0	0	0	0	1	2	0	0	0	0	0	0	2	0	0				
% Pedestrians	0.0%	0.0%	0.0%	0.0%	0.0%	100.0%	100.0%	0.0%	0.0%	0.0%	0.0%	0.0%	0.0%	0.0%	0.0%	0.0%	0.0%	0.0%	0.0%	0.0%	0.0%	0.0%	0.0%	0.0%	0.0%	0.0%	0.0%	100.0%	0.0%				
Bicycles on Crosswalk	0	0	0	0	0	0	0	0	0	0	0	0	0	0	0	0	0	0	0	0	0	0	0	0	0	0	0	0	0				
% Bicycles on Crosswalk	0.0%	0.0%	0.0%	0.0%	0.0%	0.0%	0.0%	0.0%	0.0%	0.0%	0.0%	0.0%	0.0%	0.0%	0.0%	0.0%	0.0%	0.0%	0.0%	0.0%	0.0%	0.0%	0.0%	0.0%	0.0%	0.0%	0.0%	0.0%	0.0%				

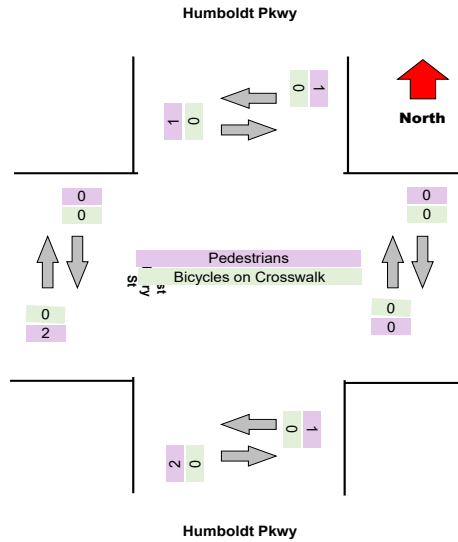
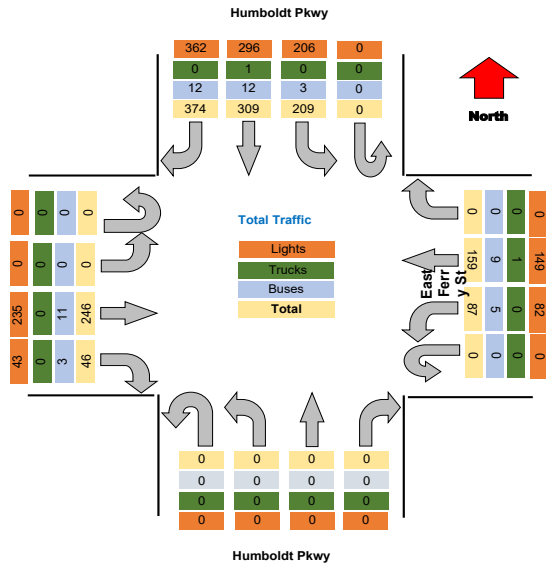

Project : VBH Malta NY
Site : Site 4
Location : 42.948550, -73.790036

TSTData.com

Survey Date : 2021-04-28, Wednesday

Turning Movement Peak Hour Data (PM)

4:15:00 PM

Leg Direction	Humboldt Pkwy				East Ferry St				Humboldt Pkwy				East Ferry St				Total							
	Southbound		Northbound		Westbound		Eastbound		Northbound		Southbound		Eastbound											
Start Time	Right	Thru	Left	U-Turn	App Total	Peds CW	Peds CCW	Right	Thru	Left	U-Turn	App Total	Peds CW	Peds CCW	Right	Thru	Left	U-Turn	App Total	Peds CW	Peds CCW			
4:15:00 PM	86	95	73	0	254	0	0	0	69	36	0	105	0	0	0	0	0	0	0	110	0	1	469	
4:30:00 PM	86	85	61	0	232	0	1	0	50	35	0	85	0	0	0	0	0	0	0	99	0	0	416	
4:45:00 PM	77	79	61	0	217	0	1	0	75	23	0	98	0	0	0	0	0	0	0	106	0	0	421	
5:00:00 PM	79	92	58	0	229	0	0	0	59	20	0	79	0	0	0	0	0	0	1	117	0	1	422	
Grand Total	328	351	253	0	932	0	1	0	250	114	0	364	0	0	0	0	0	0	1	54	368	2	1728	
% Approach	35.2%	37.7%	27.1%	0.0%	0.0%	0.0%	0.0%	14.2%	85.8%	0.0%	0.0%	0.0%	0.0%	0.0%	45.1%	41.7%	13.2%	0.0%	0.0%	0.0%	0.0%	0.0%	0.0%	
% Total	19.0%	20.3%	14.6%	0.0%	53.9%	0.0%	0.0%	0.0%	14.5%	6.6%	0.0%	21.1%	0.0%	0.0%	0.0%	0.0%	0.0%	0.0%	0.0%	3.7%	21.3%	0.0%	0.0%	25.0%
PHF	0.953	0.924	0.866	0.000	0.917	0.000	0.000	0.000	0.833	0.792	0.000	0.867	0.000	0.000	0.000	0.000	0.000	0.000	0.000	0.889	0.876	0.000	0.000	0.923
Lights	319	337	244	0	900	0	0	0	242	112	0	354	0	0	0	0	0	0	0	59	360	0	419	0
% Trucks	0.0%	0.0%	0.0%	0.0%	0.0%	0.0%	0.0%	0.0%	96.8%	98.2%	0.0%	97.3%	0.0%	0.0%	0.0%	0.0%	0.0%	0.0%	0.0%	92.2%	97.8%	0.0%	97.0%	0.0%
Buses	9	13	9	0	31	0	0	0	8	2	0	10	0	0	0	0	0	0	0	5	6	0	11	0
% Buses	2.7%	3.7%	3.6%	0.0%	0.0%	0.0%	0.0%	0.0%	3.2%	1.8%	0.0%	0.0%	0.0%	0.0%	0.0%	0.0%	0.0%	0.0%	0.0%	7.8%	1.6%	0.0%	0.0%	0.0%
Pedestrians	0	0	0	0	0	0	1	0	0	0	0	0	0	0	1	2	0	0	0	0	0	0	1	0
% Pedestrians	0.0%	0.0%	0.0%	0.0%	0.0%	0.0%	50.0%	0.0%	0.0%	0.0%	0.0%	0.0%	0.0%	0.0%	0.0%	100.0%	66.7%	0.0%	0.0%	0.0%	0.0%	0.0%	50.0%	0.0%
Bicycles on Crosswalk	0	0	0	0	0	0	1	0	0	0	0	0	0	0	0	0	0	0	0	1	0	0	1	0
% Bicycles on Crosswalk	0.0%	0.0%	0.0%	0.0%	0.0%	0.0%	50.0%	0.0%	0.0%	0.0%	0.0%	0.0%	0.0%	0.0%	0.0%	0.0%	0.0%	0.0%	0.0%	0.0%	0.0%	0.0%	50.0%	0.0%

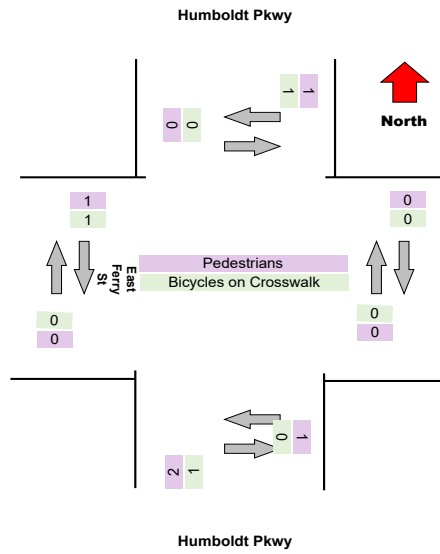
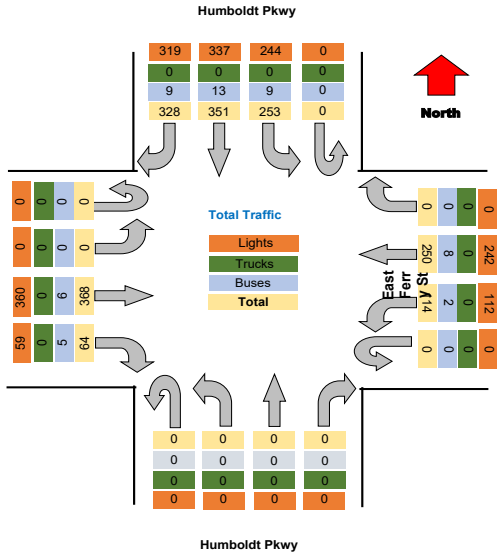

Project : VBH Malta NY
Site : Site 4
Location : 42.948550, -73.790036

TSTData.com

Survey Date : 2021-04-28, Wednesday

Project	Labella
Project Code	Labella
Site Name	9
Legs and Movements	All Processed Legs & Move
Bin Size	15 minutes
Survey Date	2021-10-26, Tuesday
Location	9
Latitude and Longitude	42.914692, -78.843108

	Start	End	PHF
Forced Peak AM	2021/10/26 07:30:00	2021/10/26 08:30:00	0.97
Forced Peak PM	2021/10/26 16:30:00	2021/10/26 17:30:00	0.91
AM Peak	2021/10/26 07:30:00	2021/10/26 08:30:00	0.97
PM Peak	2021/10/26 16:15:00	2021/10/26 17:15:00	0.94

Turning Movement Data

Leg Direction	Humboldt Pkwy										East Ferry St										Total					
	Southbound					Westbound					Northbound					Eastbound										
	Right	Thru	Left	U-Turn	App Total	Right	Thru	Left	U-Turn	App Total	Right	Thru	Left	U-Turn	App Total	Right	Thru	Left	U-Turn	App Total						
Start Time	Right	Thru	Left	U-Turn	App Total	Right	Thru	Left	U-Turn	App Total	Right	Thru	Left	U-Turn	App Total	Right	Thru	Left	U-Turn	App Total						
6:30:00 AM	0	0	0	0	0	6	20	0	0	26	0	0	0	0	0	2	24	11	0	37	0	0	0	0	0	119
6:45:00 AM	0	0	0	0	0	11	29	0	0	40	0	0	0	0	0	7	26	6	0	41	0	0	0	0	0	135
Hourly Total	0	0	0	0	0	17	49	0	0	66	0	0	0	0	0	9	50	17	0	76	0	0	0	0	0	254
7:00:00 AM	0	0	0	0	0	13	29	0	0	43	0	0	0	0	0	8	37	10	0	55	1	0	0	0	0	166
7:15:00 AM	0	0	0	0	0	13	32	0	0	47	0	0	0	0	0	4	33	6	0	43	0	1	0	0	0	149
7:30:00 AM	0	0	0	0	1	13	42	0	0	55	0	0	0	0	0	5	41	11	0	57	0	2	0	0	0	236
7:45:00 AM	0	0	0	0	1	11	47	0	0	59	0	0	0	0	0	11	53	7	0	71	1	1	0	0	0	246
Hourly Total	0	0	0	0	2	50	150	0	0	204	0	0	0	0	0	28	164	34	0	226	2	4	0	0	0	797
8:00:00 AM	0	0	0	0	0	17	46	0	0	63	0	0	0	0	0	6	47	16	0	69	0	1	0	0	0	232
8:15:00 AM	0	0	0	0	1	15	70	0	0	86	0	0	0	0	0	11	43	12	0	66	0	0	0	0	0	242
Hourly Total	0	0	0	0	1	32	116	0	0	149	0	0	0	0	0	17	90	28	0	135	0	1	0	0	0	474
4:00:00 PM	0	0	0	0	0	15	67	0	0	82	0	0	0	0	0	15	50	23	0	88	1	2	0	0	0	329
4:15:00 PM	0	0	0	0	1	23	81	0	0	104	0	0	0	0	0	12	51	12	0	75	0	1	0	0	0	329
4:30:00 PM	0	0	0	0	0	22	81	0	0	103	0	0	0	0	0	15	51	11	0	77	0	1	0	0	0	330
4:45:00 PM	0	0	0	0	1	11	80	0	0	91	0	0	0	0	0	16	43	13	0	72	0	0	0	0	0	289
Hourly Total	0	0	0	0	2	71	309	0	0	380	0	0	0	0	0	58	195	59	0	312	1	4	0	0	0	1277
5:00:00 PM	0	0	0	0	0	18	73	0	0	91	0	0	0	0	0	10	44	20	0	74	0	1	0	0	0	298
5:15:00 PM	0	0	0	0	0	21	59	0	0	80	0	0	0	0	0	12	58	12	0	82	0	0	0	0	0	283
5:30:00 PM	0	0	0	0	0	17	64	0	0	81	0	1	0	0	0	6	45	18	0	69	1	0	0	0	0	295
5:45:00 PM	0	0	0	0	0	19	54	0	0	73	0	0	0	0	0	6	38	12	0	56	0	0	0	0	0	236
Hourly Total	0	0	0	0	2	75	250	0	0	325	0	1	0	0	0	34	185	62	0	281	1	1	0	0	0	1112
Grand Total	0	0	0	0	3	245	874	0	0	1124	0	3	0	0	0	146	684	200	0	1032	4	10	0	0	0	3914
% Approach	0.0%	0.0%	0.0%	0.0%	0.0%	21.8%	77.8%	0.0%	0.0%	0.0%	0.0%	0.0%	0.0%	0.0%	0.0%	14.1%	66.3%	19.4%	0.0%	0.0%	0.0%	0.0%	0.0%	0.0%	0.0%	0.0%
% Total	0.0%	0.0%	0.0%	0.0%	0.0%	6.3%	22.3%	0.0%	0.0%	28.7%	0.0%	0.0%	0.0%	0.0%	0.0%	3.7%	17.5%	5.1%	0.0%	26.4%	0.0%	0.0%	0.0%	0.0%	0.0%	0.0%
Lights	0	0	0	0	0	227	831	0	0	1058	0	0	0	0	0	134	654	187	0	975	0	0	0	0	0	3733
% Lights	0.0%	0.0%	0.0%	0.0%	0.0%	92.7%	95.1%	0.0%	0.0%	94.1%	0.0%	0.0%	0.0%	0.0%	0.0%	91.8%	95.6%	93.5%	0.0%	94.5%	0.0%	0.0%	0.0%	0.0%	0.0%	95.4%
Trucks	0	0	0	0	0	0	0	0	0	0	0	0	0	0	0	0	0	0	0	0	0	0	0	0	0	0
% Trucks	0.0%	0.0%	0.0%	0.0%	0.0%	0.0%	0.0%	0.0%	0.0%	0.0%	0.0%	0.0%	0.0%	0.0%	0.0%	0.0%	0.0%	0.0%	0.0%	0.0%	0.0%	0.0%	0.0%	0.0%	0.0%	0.0%
Buses	0	0	0	0	0	18	43	0	0	61	0	0	0	0	0	12	30	13	0	55	0	0	0	0	0	174
% Buses	0.0%	0.0%	0.0%	0.0%	0.0%	0.0%	4.9%	0.0%	0.0%	0.0%	0.0%	0.0%	0.0%	0.0%	0.0%	8.2%	4.4%	6.5%	0.0%	0.0%	0.0%	0.0%	0.0%	0.0%	0.0%	4.4%
Pedestrians	0	0	0	0	0	2	9	0	0	0	0	0	0	0	0	0	0	0	0	0	4	10	0	0	0	0
% Pedestrians	0.0%	0.0%	0.0%	0.0%	0.0%	0.8%	66.7%	100.0%	0.0%	0.0%	0.0%	0.0%	0.0%	0.0%	0.0%	0.0%	0.0%	0.0%	0.0%	0.0%	100.0%	100.0%	0.0%	0.0%	0.0%	0.0%
Bicycles on Crosswalk	0	0	0	0	0	1	0	0	0	0	0	0	0	0	0	0	0	0	0	0	0	0	0	0	0	0
% Bicycles on Crosswalk	0.0%	0.0%	0.0%	0.0%	0.0%	0.4%	33.3%	0.0%	0.0%	0.0%	0.0%	0.0%	0.0%	0.0%	0.0%	0.0%	0.0%	0.0%	0.0%	0.0%	0.0%	0.0%	0.0%	0.0%	0.0%	0.0%

Project : VBH Malta NY
 Site : Site 4
 Location : 42.948550, -73.790036
 Survey Date : 2021-04-28, Wednesday

Turning Movement Data Plot

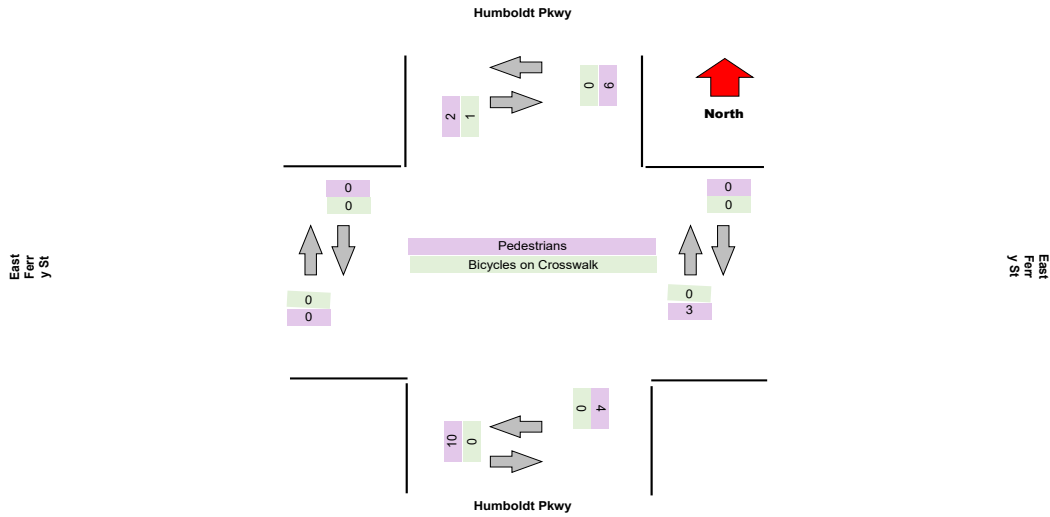
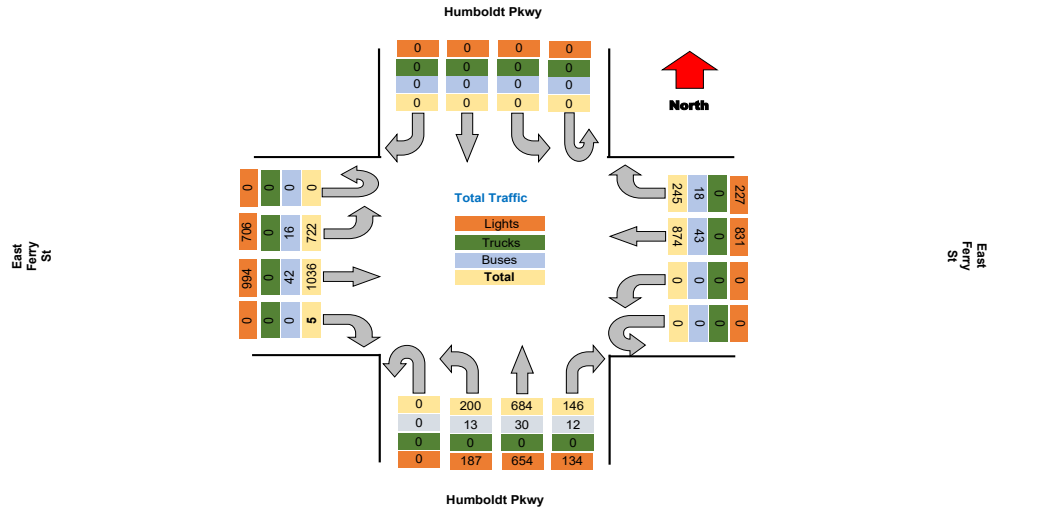

Turning Movement Peak Hour Data (AM)

7:30:00 AM

Leg Direction	Humboldt Pkwy				East Ferry St				Humboldt Pkwy				East Ferry St				Total		
	Right	Thru	Left	U-Turn	Right	Thru	Left	U-Turn	Right	Thru	Left	U-Turn	Right	Thru	Left	U-Turn			
Start Time																			
7:30:00 AM	0	0	0	0	13	42	0	0	55	0	0	0	5	41	11	0	67	57	124
7:45:00 AM	0	0	0	0	0	1	1	1	11	47	0	0	59	0	0	0	11	53	7
8:00:00 AM	0	0	0	0	0	0	0	0	17	46	0	0	63	0	0	0	6	47	16
8:15:00 AM	0	0	0	0	1	1	1	1	15	70	0	0	66	0	0	0	11	43	12
Grand Total	0	0	0	0	3	7	3	3	56	205	0	0	253	0	0	0	33	194	46
% Approach	#DIV/0!	#DIV/0!	#DIV/0!	#DIV/0!	0.0%	0.0%	0.0%	0.0%	14.2%	85.8%	0.0%	0.0%	0.0%	0.0%	0.0%	0.0%	45.1%	41.7%	13.2%
% Total	0.0%	0.0%	0.0%	0.0%	0.0%	0.0%	0.0%	0.0%	5.9%	21.4%	0.0%	0.0%	27.5%	0.0%	0.0%	0.0%	3.5%	19.2%	4.8%
PHF	0.000	0.000	0.000	0.000	0.000	0.000	0.000	0.000	0.824	0.732	0.000	0.000	0.765	0.000	0.000	0.000	0.750	0.868	0.719
Lights	0	0	0	0	53	194	0	0	247	0	0	0	29	177	43	0	249	0	0
% Lights	0.0%	0.0%	0.0%	0.0%	0.0%	0.0%	0.0%	0.0%	94.6%	94.6%	0.0%	0.0%	93.9%	0.0%	0.0%	0.0%	87.9%	96.2%	93.5%
Trucks	0	0	0	0	0	0	0	0	0	0	0	0	0	0	0	0	0	0	0
% Trucks	0.0%	0.0%	0.0%	0.0%	0.0%	0.0%	0.0%	0.0%	0.0%	0.0%	0.0%	0.0%	0.0%	0.0%	0.0%	0.0%	0.0%	0.0%	0.0%
Buses	0	0	0	0	3	11	0	0	14	0	0	0	4	7	3	0	14	0	0
% Buses	0.0%	0.0%	0.0%	0.0%	0.0%	0.0%	0.0%	0.0%	5.4%	5.4%	0.0%	0.0%	0.0%	0.0%	0.0%	0.0%	12.1%	3.8%	6.5%
Pedestrians	0	0	0	0	2	2	0	0	0	0	0	0	0	0	0	0	1	4	0
% Pedestrians	0.0%	0.0%	0.0%	0.0%	0.0%	66.7%	100.0%	0.0%	0.0%	0.0%	0.0%	0.0%	0.0%	0.0%	0.0%	0.0%	0.0%	100.0%	100.0%
Bicycles on Crosswalk	0	0	0	0	1	0	0	0	0	0	0	0	0	0	0	0	0	0	0
% Bicycles on Crosswalk	0.0%	0.0%	0.0%	0.0%	0.0%	33.3%	0.0%	0.0%	0.0%	0.0%	0.0%	0.0%	0.0%	0.0%	0.0%	0.0%	0.0%	0.0%	0.0%

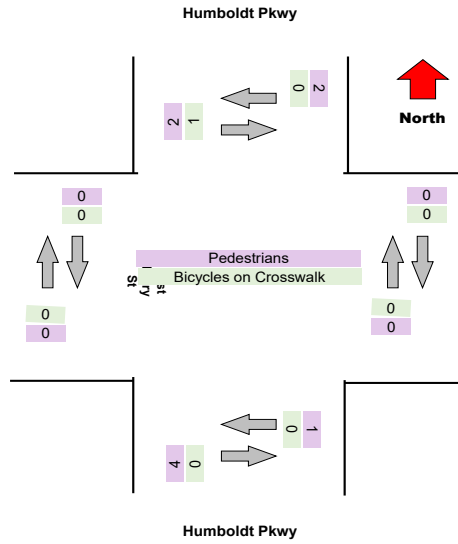
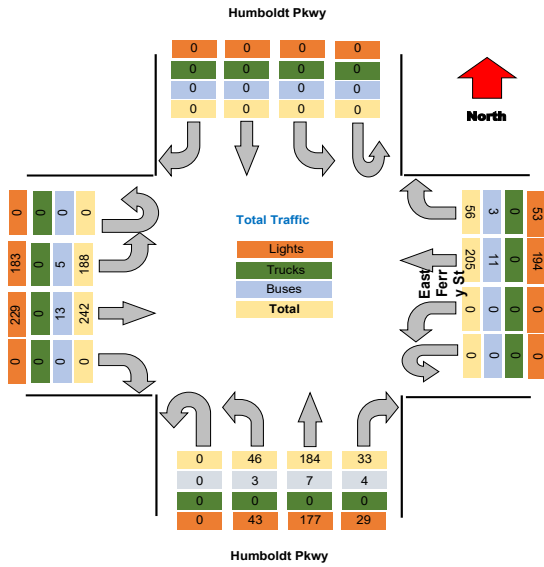

Turning Movement Peak Hour Data (PM)

4:15:00 PM

Leg Direction	Humboldt Pkwy				East Ferry St				Humboldt Pkwy				East Ferry St				Total					
	Southbound				Westbound				Northbound				Eastbound									
Start Time	Right	Thru	Left	U-Turn	App Total	Peds CW	Peds CCW	Right	Thru	Left	U-Turn	App Total	Peds CW	Peds CCW	Right	Thru	Left	U-Turn	App Total	Peds CW	Peds CCW	
4:15:00 PM	0	0	0	0	0	0	0	23	81	0	0	104	0	0	12	51	12	0	75	0	0	329
4:30:00 PM	0	0	0	0	0	0	0	22	81	0	0	103	0	0	15	51	11	0	77	0	1	330
4:45:00 PM	0	0	0	0	0	0	1	11	80	0	0	91	0	0	16	43	13	0	72	0	0	289
5:00:00 PM	0	0	0	0	0	0	2	18	73	0	0	91	0	0	10	44	20	0	74	0	1	238
Grand Total	0	0	0	0	0	0	3	74	315	0	0	389	0	0	33	189	56	0	288	0	2	1246
% Approach	#DIV/0!	#DIV/0!	#DIV/0!	#DIV/0!	0.0%	0.0%	0.0%	14.2%	85.8%	0.0%	0.0%	0.0%	0.0%	0.0%	45.1%	41.7%	13.2%	0.0%	0.0%	0.0%	0.0%	0.0%
% Total	0.0%	0.0%	0.0%	0.0%	0.0%	0.0%	0.0%	5.9%	25.3%	0.0%	0.0%	31.2%	0.0%	0.0%	4.3%	15.2%	4.5%	0.0%	23.9%	0.0%	0.0%	0.0%
PHF	0.000	0.000	0.000	0.000	0.000	0.000	0.000	0.804	0.972	0.000	0.000	0.935	0.000	0.000	0.828	0.926	0.700	0.000	0.868	0.000	0.000	0.944
Lights	0	0	0	0	0	0	0	71	301	0	0	372	0	0	50	177	53	0	280	0	0	1197
% Lights	0.0%	0.0%	0.0%	0.0%	0.0%	0.0%	0.0%	85.9%	95.6%	0.0%	0.0%	95.6%	0.0%	0.0%	84.3%	93.7%	94.6%	0.0%	94.0%	0.0%	0.0%	96.1%
Trucks	0	0	0	0	0	0	0	0	0	0	0	0	0	0	0	0	0	0	0	0	0	0
% Trucks	0.0%	0.0%	0.0%	0.0%	0.0%	0.0%	0.0%	0.0%	0.0%	0.0%	0.0%	0.0%	0.0%	0.0%	0.0%	0.0%	0.0%	0.0%	0.0%	0.0%	0.0%	0.0%
Buses	0	0	0	0	0	0	0	3	14	0	0	17	0	0	3	12	3	0	18	0	0	49
% Buses	0.0%	0.0%	0.0%	0.0%	0.0%	0.0%	0.0%	4.1%	4.4%	0.0%	0.0%	0.0%	0.0%	0.0%	5.7%	6.3%	5.4%	0.0%	0.0%	0.0%	0.0%	3.9%
Pedestrians	0	0	0	0	0	4	0	0	0	0	0	0	0	3	0	0	0	0	0	0	0	0
% Pedestrians	0.0%	0.0%	0.0%	0.0%	0.0%	100.0%	0.0%	0.0%	0.0%	0.0%	0.0%	0.0%	0.0%	100.0%	0.0%	0.0%	0.0%	0.0%	0.0%	0.0%	0.0%	0.0%
Bicycles on Crosswalk	0	0	0	0	0	0	0	0	0	0	0	0	0	0	0	0	0	0	0	0	0	0
% Bicycles on Crosswalk	0.0%	0.0%	0.0%	0.0%	0.0%	0.0%	0.0%	0.0%	0.0%	0.0%	0.0%	0.0%	0.0%	0.0%	0.0%	0.0%	0.0%	0.0%	0.0%	0.0%	0.0%	0.0%

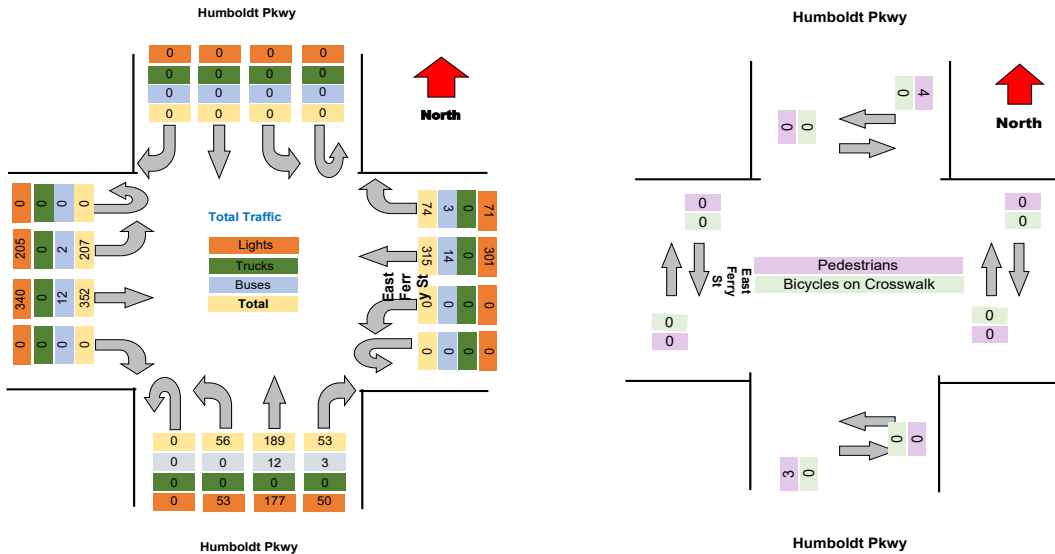

Project : VBH Malta NY
 Site : Site 4
 Location : 42.948550, -73.790036
 Survey Date : 2021-04-28, Wednesday

Turning Movement Data Plot

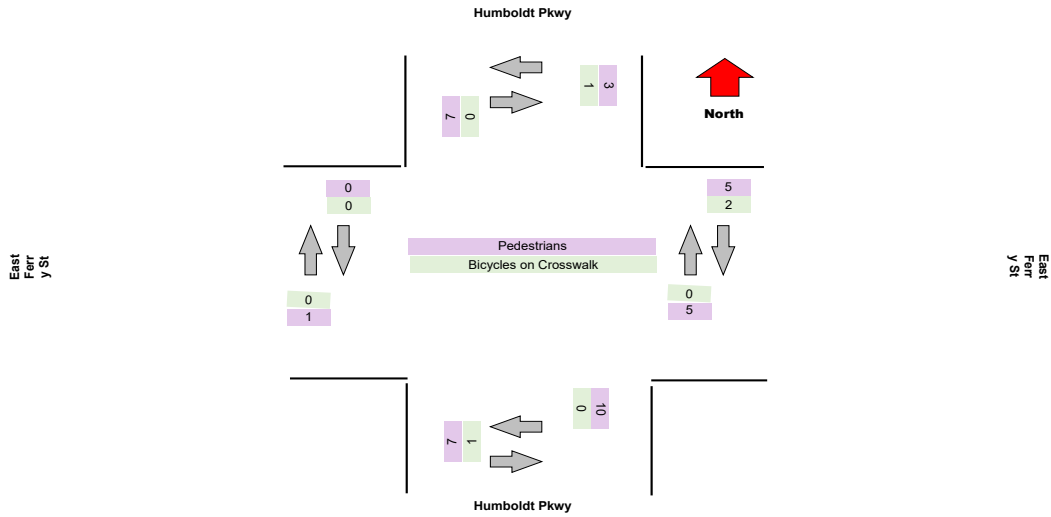
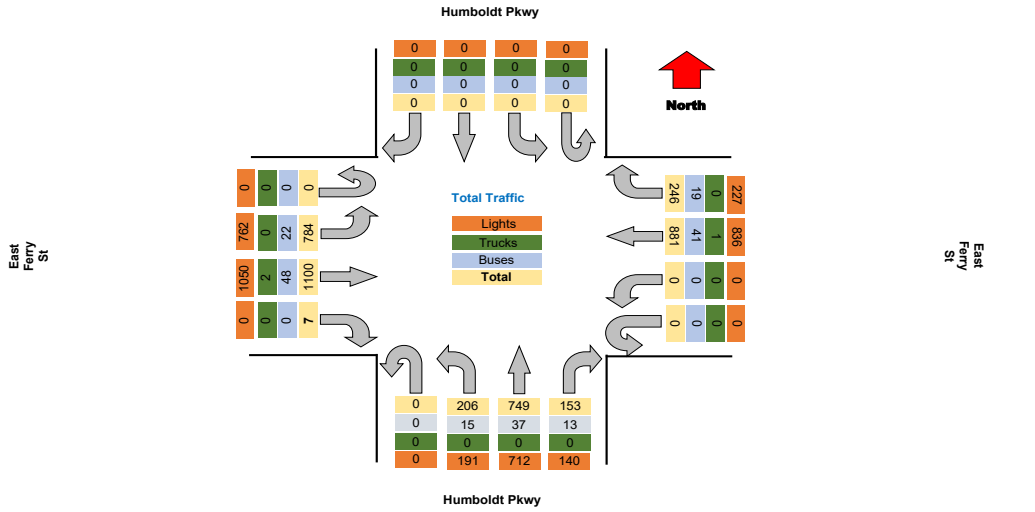

Turning Movement Peak Hour Data (AM)

7:30:00 AM

Leg Direction	Humboldt Pkwy							East Ferry St							Humboldt Pkwy							East Ferry St							Total
	Southbound				Westbound			Northbound				Eastbound			Northbound				Eastbound										
Start Time	Right	Thru	Left	U-Turn	App Total	Peds CW	Peds CCW	Right	Thru	Left	U-Turn	App Total	Peds CW	Peds CCW	Right	Thru	Left	U-Turn	App Total	Peds CW	Peds CCW	Right	Thru	Left	U-Turn	App Total	Peds CW	Peds CCW	
7:30:00 AM	0	0	0	0	0	0	0	15	37	0	0	52	1	0	7	45	10	0	63	1	1	0	62	54	0	116	0	0	231
7:45:00 AM	0	0	0	0	0	1	0	16	66	0	0	82	0	0	18	46	7	0	71	0	0	0	78	42	0	120	0	0	273
8:00:00 AM	0	0	0	0	0	0	0	10	52	0	0	62	0	0	9	54	18	0	81	0	0	0	66	44	0	110	0	0	253
8:15:00 AM	0	0	0	0	0	0	0	15	58	0	0	73	0	0	8	27	11	0	47	0	0	0	57	38	0	95	0	0	215
Grand Total	0	0	0	0	0	1	0	56	213	0	0	259	1	0	43	172	46	0	252	1	1	0	253	178	0	441	0	0	972
% Approach	#DIV/0!	#DIV/0!	#DIV/0!	#DIV/0!	0.0%	0.0%	0.0%	14.2%	85.8%	0.0%	0.0%	0.0%	0.0%	0.0%	45.1%	41.7%	13.2%	0.0%	0.0%	0.0%	0.0%	0.0%	66.2%	33.8%	0.0%	0.0%	0.0%	0.0%	
% Total	0.0%	0.0%	0.0%	0.0%	0.0%	0.0%	0.0%	5.8%	21.9%	0.0%	0.0%	27.0%	0.0%	0.0%	4.4%	17.7%	4.7%	0.0%	27.0%	0.0%	0.0%	0.0%	27.1%	18.3%	0.0%	45.4%	0.0%	0.0%	
PHF	0.000	0.000	0.000	0.000	0.000	0.000	0.000	0.875	0.807	0.000	0.000	0.820	0.000	0.000	0.597	0.796	0.639	0.000	0.809	0.000	0.000	0.000	0.843	0.824	0.000	0.919	0.000	0.000	0.890
Lights	0	0	0	0	0	0	0	53	200	0	0	253	0	0	39	165	42	0	246	0	0	0	251	171	0	422	0	0	921
% Lights	0.0%	0.0%	0.0%	0.0%	0.0%	0.0%	0.0%	84.6%	93.9%	0.0%	0.0%	84.1%	0.0%	0.0%	80.7%	95.0%	91.3%	0.0%	93.9%	0.0%	0.0%	0.0%	95.4%	96.1%	0.0%	95.7%	0.0%	0.0%	94.8%
Trucks	0	0	0	0	0	0	0	0	1	0	0	1	0	0	0	0	0	0	0	0	0	0	0	0	0	0	0	0	1
% Trucks	0.0%	0.0%	0.0%	0.0%	0.0%	0.0%	0.0%	0.0%	0.5%	0.0%	0.0%	0.4%	0.0%	0.0%	0.0%	0.0%	0.0%	0.0%	0.0%	0.0%	0.0%	0.0%	0.0%	0.0%	0.0%	0.0%	0.0%	0.0%	0.1%
Buses	0	0	0	0	0	0	0	3	12	0	0	15	0	0	4	7	4	0	15	0	0	0	12	7	0	19	0	0	49
% Buses	0.0%	0.0%	0.0%	0.0%	0.0%	0.0%	0.0%	5.4%	5.6%	0.0%	0.0%	0.0%	0.0%	0.0%	9.3%	4.1%	8.7%	0.0%	0.0%	0.0%	0.0%	0.0%	4.8%	3.9%	0.0%	0.0%	0.0%	0.0%	5.0%
Pedestrians	0	0	0	0	0	1	0	0	0	0	0	0	1	0	0	0	0	0	1	1	0	0	0	0	0	0	0	0	0
% Pedestrians	0.0%	0.0%	0.0%	0.0%	0.0%	100.0%	0.0%	0.0%	0.0%	0.0%	0.0%	0.0%	100.0%	0.0%	0.0%	0.0%	0.0%	0.0%	0.0%	100.0%	100.0%	0.0%	0.0%	0.0%	0.0%	0.0%	0.0%	0.0%	0.0%
Bicycles on Crosswalk	0	0	0	0	0	0	0	0	0	0	0	0	0	0	0	0	0	0	0	0	0	0	0	0	0	0	0	0	0
% Bicycles on Crosswalk	0.0%	0.0%	0.0%	0.0%	0.0%	0.0%	0.0%	0.0%	0.0%	0.0%	0.0%	0.0%	0.0%	0.0%	0.0%	0.0%	0.0%	0.0%	0.0%	0.0%	0.0%	0.0%	0.0%	0.0%	0.0%	0.0%	0.0%	0.0%	0.0%

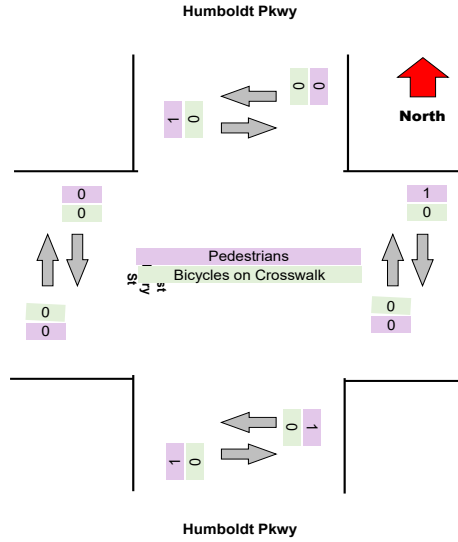
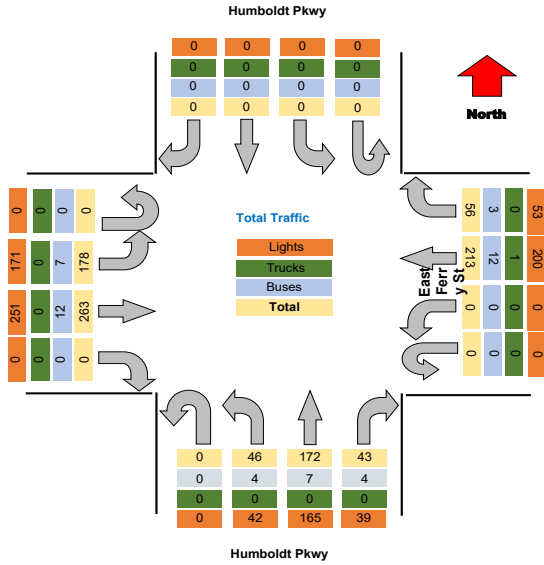

Project : VBH Malta NY
Site : Site 4
Location : 42.948550, -73.790036

TSTData.com

Survey Date : 2021-04-28, Wednesday

Turning Movement Peak Hour Data (PM)

4:15:00 PM

Leg Direction	Humboldt Pkwy						East Ferry St						Humboldt Pkwy						East Ferry St						Total			
	Southbound			Northbound			Westbound			Eastbound			Northbound			Eastbound												
Start Time	Right	Thru	Left	U-Turn	App Total	Peds CW	Peds CCW	Right	Thru	Left	U-Turn	App Total	Peds CW	Peds CCW	Right	Thru	Left	U-Turn	App Total	Peds CW	Peds CCW	Total						
4:15:00 PM	0	0	0	0	0	0	0	22	81	0	0	103	3	0	14	57	27	0	98	4	4	190	0	0	391			
4:30:00 PM	0	0	0	0	0	0	0	12	77	0	0	89	0	1	7	69	11	0	87	0	0	159	0	0	335			
4:45:00 PM	0	0	0	0	0	0	0	17	76	0	0	93	2	0	11	53	14	0	78	0	1	140	1	0	311			
5:00:00 PM	0	0	0	0	0	0	0	27	62	0	0	109	0	0	14	48	16	0	78	2	0	132	0	0	319			
Grand Total	0	0	0	0	0	0	0	78	316	0	0	394	5	1	46	227	68	0	341	6	5	621	1	0	1356			
% Approach	#DIV/0!	#DIV/0!	#DIV/0!	#DIV/0!	0.0%	0.0%	0.0%	14.2%	85.8%	0.0%	0.0%	0.0%	0.0%	0.0%	45.1%	41.7%	13.2%	0.0%	0.0%	0.0%	0.0%	0.0%	0.0%	0.0%	0.0%	0.0%		
% Total	0.0%	0.0%	0.0%	0.0%	0.0%	0.0%	0.0%	5.8%	23.3%	0.0%	0.0%	29.1%	0.0%	0.0%	3.4%	16.7%	5.0%	0.0%	25.1%	0.0%	0.0%	0.0%	0.0%	0.0%	0.0%	0.0%		
PHF	0.000	0.000	0.000	0.000	0.000	0.000	0.000	0.722	0.963	0.000	0.000	0.904	0.000	0.000	0.821	0.822	0.630	0.000	0.870	0.000	0.000	0.000	0.000	0.000	0.867	0.000		
Lights	0	0	0	0	0	0	0	75	303	0	0	378	0	0	42	211	63	0	316	0	0	603	0	0	1297			
% Lights	0.0%	0.0%	0.0%	0.0%	0.0%	0.0%	0.0%	96.2%	95.9%	0.0%	0.0%	95.9%	0.0%	0.0%	81.3%	93.0%	92.6%	0.0%	92.7%	0.0%	0.0%	96.3%	98.1%	0.0%	97.1%	0.0%	0.0%	
Trucks	0	0	0	0	0	0	0	0	0	0	0	0	0	0	0	0	0	0	0	0	0	0	0	0	0	0		
% Trucks	0.0%	0.0%	0.0%	0.0%	0.0%	0.0%	0.0%	0.0%	0.0%	0.0%	0.0%	0.0%	0.0%	0.0%	0.0%	0.0%	0.0%	0.0%	0.0%	0.0%	0.0%	0.0%	0.0%	0.0%	0.0%	0.0%	0.0%	
Buses	0	0	0	0	0	0	0	3	11	0	0	14	0	0	4	16	5	0	25	0	0	13	5	0	18	0	0	
% Buses	0.0%	0.0%	0.0%	0.0%	0.0%	0.0%	0.0%	3.8%	3.5%	0.0%	0.0%	3.8%	0.0%	0.0%	8.7%	7.0%	7.4%	0.0%	0.0%	0.0%	3.7%	1.9%	0.0%	0.0%	0.0%	0.0%	4.2%	
Pedestrians	0	0	0	0	0	0	0	0	0	0	0	3	1	1	0	0	0	0	6	6	4	0	0	0	0	1	0	
% Pedestrians	0.0%	0.0%	0.0%	0.0%	0.0%	0.0%	0.0%	0.0%	0.0%	0.0%	0.0%	0.8%	60.0%	100.0%	0.0%	0.0%	0.0%	0.0%	0.0%	0.0%	0.0%	0.0%	0.0%	0.0%	0.0%	100.0%	0.0%	0.0%
Bicycles on Crosswalk	0	0	0	0	0	0	0	0	0	0	0	2	0	0	0	0	0	0	0	0	1	0	0	0	0	0	0	
% Bicycles on Crosswalk	0.0%	0.0%	0.0%	0.0%	0.0%	0.0%	0.0%	0.0%	0.0%	0.0%	0.0%	0.6%	40.0%	0.0%	0.0%	0.0%	0.0%	0.0%	0.0%	0.0%	0.0%	0.0%	0.0%	0.0%	0.0%	0.0%	0.0%	0.0%

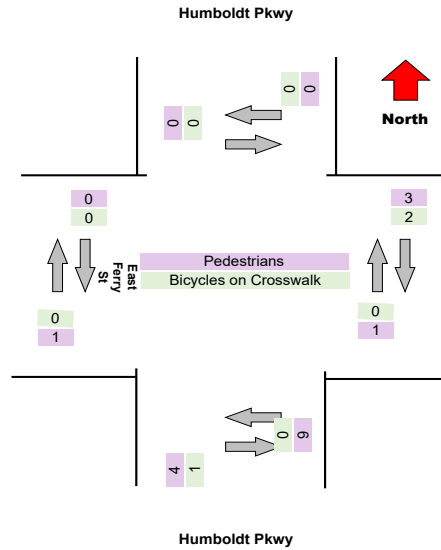
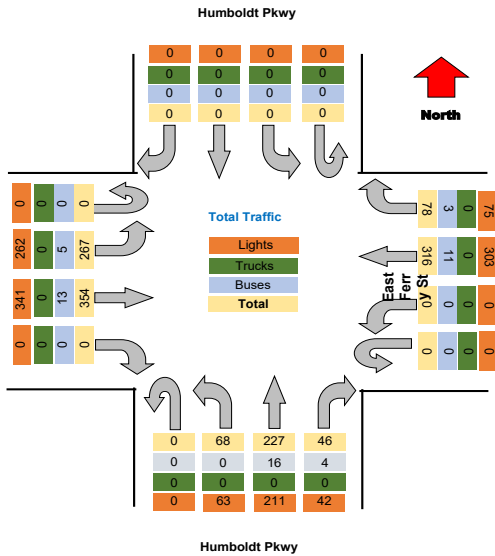

Turning Movement Data Plot

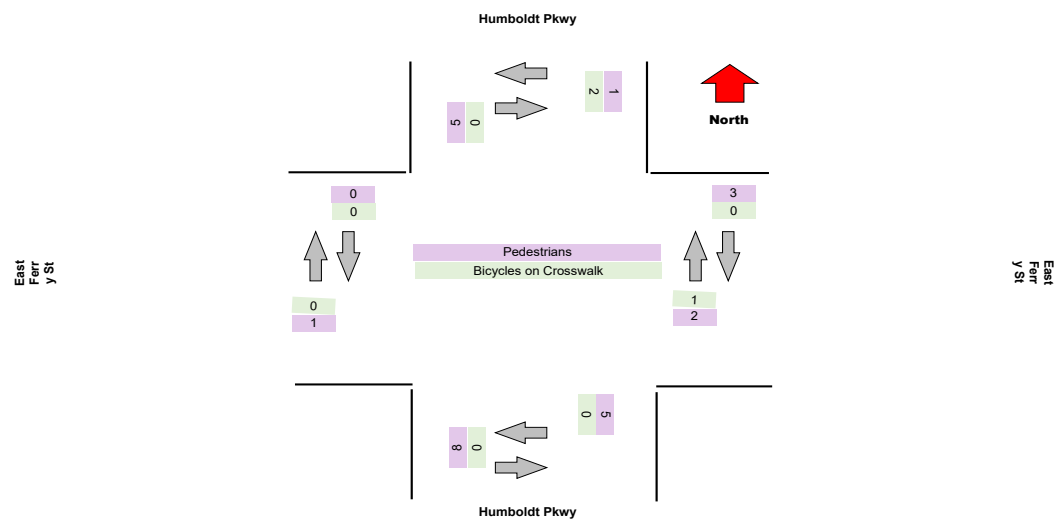
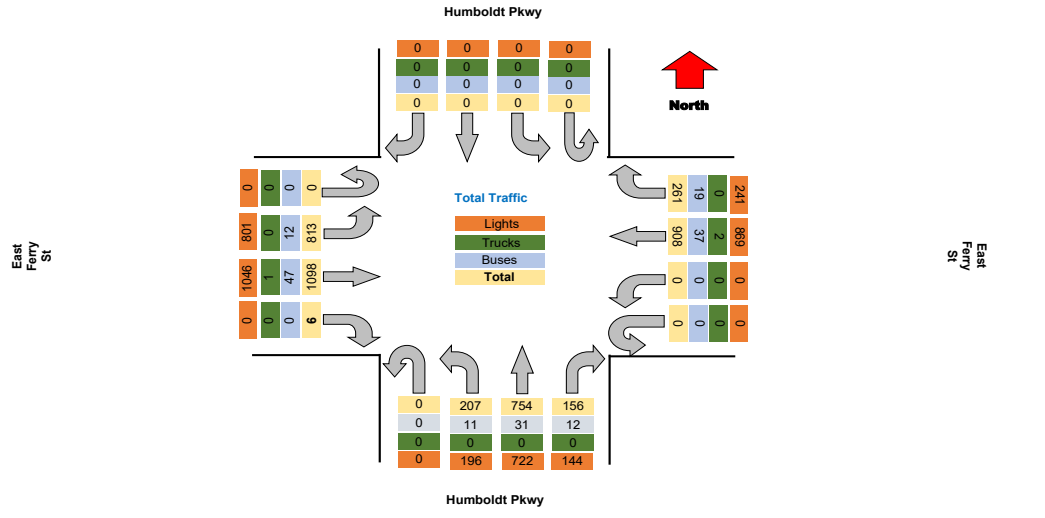

Turning Movement Peak Hour Data (AM)

7:30:00 AM

Leg	Humboldt Pkwy								East Ferry St								Humboldt Pkwy								East Ferry St								Total			
	Southbound				Northbound				Westbound				Eastbound				Northbound				Eastbound															
Direction	Right	Thru	Left	U-Turn	App Total	Peds CW	Peds CCW	Right	Thru	Left	U-Turn	App Total	Peds CW	Peds CCW	Right	Thru	Left	U-Turn	App Total	Peds CW	Peds CCW	Right	Thru	Left	U-Turn	App Total	Peds CW	Peds CCW								
7:30:00 AM	0	0	0	0	0	0	0	21	41	0	0	62	0	0	6	39	12	0	57	0	2	0	61	57	0	118	0	0	0	0	0	0	0	0	0	237
7:45:00 AM	0	0	0	0	0	0	0	14	53	0	0	67	0	0	12	58	10	0	80	0	0	0	65	56	0	121	0	0	0	0	0	0	0	0	0	268
8:00:00 AM	0	0	0	0	0	0	0	13	49	0	0	62	0	0	8	53	12	0	73	0	0	0	76	49	0	125	0	0	0	0	0	0	0	0	0	260
8:15:00 AM	0	0	0	0	0	0	0	13	64	0	0	77	0	0	11	32	8	0	51	0	0	0	52	44	0	96	0	0	0	0	0	0	0	0	0	225
Grand Total	0	0	0	0	0	0	0	61	207	0	0	259	0	0	37	192	42	0	251	0	2	0	254	206	0	460	0	0	0	0	0	0	0	0	0	990
% Approach	#DIV/0!	#DIV/0!	#DIV/0!	#DIV/0!	0.0%	0.0%	0.0%	14.2%	85.8%	0.0%	0.0%	0.0%	0.0%	0.0%	45.1%	41.7%	13.2%	0.0%	0.0%	0.0%	0.0%	0.0%	66.2%	33.8%	0.0%	0.0%	0.0%	0.0%	0.0%	0.0%						
% Total	0.0%	0.0%	0.0%	0.0%	0.0%	0.0%	0.0%	6.2%	20.9%	0.0%	0.0%	27.2%	0.0%	0.0%	3.7%	18.4%	4.2%	0.0%	26.4%	0.0%	0.0%	0.0%	25.7%	20.8%	0.0%	46.5%	0.0%	0.0%	0.0%	0.0%	0.0%	0.0%	0.0%	0.0%	0.0%	
PHF	0.000	0.000	0.000	0.000	0.000	0.000	0.000	0.726	0.809	0.000	0.000	0.882	0.000	0.000	0.771	0.784	0.875	0.000	0.816	0.000	0.000	0.000	0.836	0.904	0.000	0.920	0.000	0.000	0.000	0.000	0.000	0.000	0.000	0.000	0.000	0.924
Lights	0	0	0	0	0	0	0	58	196	0	0	254	0	0	34	174	38	0	246	0	0	0	245	201	0	446	0	0	0	0	0	0	0	0	0	946
% Lights	0.0%	0.0%	0.0%	0.0%	0.0%	0.0%	0.0%	95.1%	94.7%	0.0%	0.0%	94.4%	0.0%	0.0%	81.9%	95.6%	90.5%	0.0%	94.3%	0.0%	0.0%	0.0%	96.5%	97.6%	0.0%	97.0%	0.0%	0.0%	0.0%	0.0%	0.0%	0.0%	0.0%	0.0%	0.0%	95.6%
Trucks	0	0	0	0	0	0	0	0	1	0	0	1	0	0	0	0	0	0	0	0	0	0	0	0	0	0	0	0	0	0	0	0	0	1		
% Trucks	0.0%	0.0%	0.0%	0.0%	0.0%	0.0%	0.0%	0.0%	0.5%	0.0%	0.0%	0.4%	0.0%	0.0%	0.0%	0.0%	0.0%	0.0%	0.0%	0.0%	0.0%	0.0%	0.0%	0.0%	0.0%	0.0%	0.0%	0.0%	0.0%	0.0%	0.0%	0.0%	0.0%	0.1%		
Buses	0	0	0	0	0	0	0	3	10	0	0	13	0	0	3	8	4	0	15	0	0	0	9	5	0	14	0	0	0	0	0	0	0	0	0	42
% Buses	0.0%	0.0%	0.0%	0.0%	0.0%	0.0%	0.0%	4.9%	4.8%	0.0%	0.0%	5.0%	0.0%	0.0%	8.1%	4.4%	9.5%	0.0%	6.0%	0.0%	0.0%	0.0%	3.5%	2.4%	0.0%	3.0%	0.0%	0.0%	0.0%	0.0%	0.0%	0.0%	0.0%	0.0%	0.0%	4.2%
Pedestrians	0	0	0	0	0	1	0	0	0	0	0	0	0	0	0	0	0	0	0	0	2	0	0	0	0	0	0	0	0	0	0	0	0			
% Pedestrians	0.0%	0.0%	0.0%	0.0%	0.0%	100.0%	0.0%	0.0%	0.0%	0.0%	0.0%	0.0%	0.0%	0.0%	0.0%	0.0%	0.0%	0.0%	0.0%	0.0%	0.8%	0.0%	100.0%	0.0%	0.0%	0.0%	0.0%	0.0%	0.0%	0.0%	0.0%	0.0%	0.0%	0.0%		
Bicycles on Crosswalk	0	0	0	0	0	1	0	0	0	0	0	0	0	0	0	0	0	0	0	0	0	0	0	0	0	0	0	0	0	0	0	0	0	0		
% Bicycles on Crosswalk	0.0%	0.0%	0.0%	0.0%	0.0%	100.0%	0.0%	0.0%	0.0%	0.0%	0.0%	0.0%	0.0%	0.0%	0.0%	0.0%	0.0%	0.0%	0.0%	0.0%	0.0%	0.0%	100.0%	0.0%	0.0%	0.0%	0.0%	0.0%	0.0%	0.0%	0.0%	0.0%	0.0%	0.0%	0.0%	

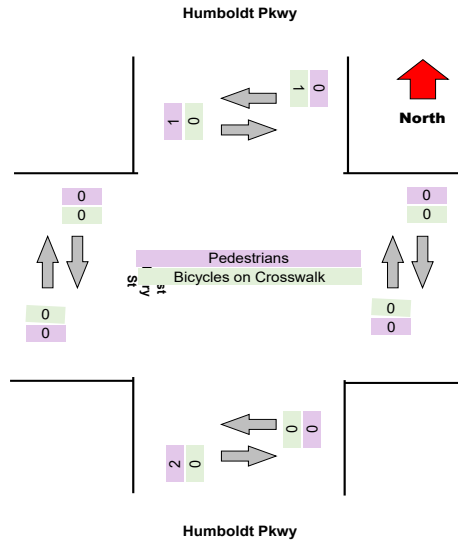
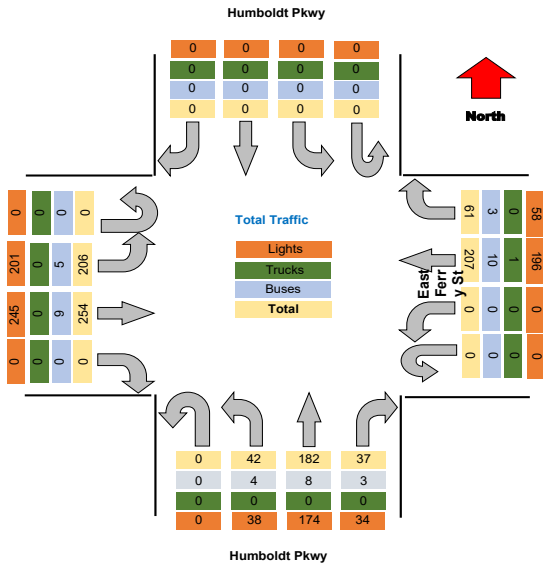

Project : VBH Malta NY
Site : Site 4
Location : 42.948550, -73.790036

TSTData.com

Survey Date : 2021-04-28, Wednesday

Turning Movement Peak Hour Data (PM)

4:15:00 PM

Leg Direction	Humboldt Pkwy						East Ferry St						Humboldt Pkwy						East Ferry St						Total				
	Southbound			Northbound			Westbound			Eastbound			Northbound			Eastbound													
Start Time	Right	Thru	Left	U-Turn	App Total	Peds CW	Peds CCW	Right	Thru	Left	U-Turn	App Total	Peds CW	Peds CCW	Right	Thru	Left	U-Turn	App Total	Peds CW	Peds CCW	Right	Thru	Left	U-Turn	App Total	Peds CW	Peds CCW	
4:15:00 PM	0	0	0	0	0	0	0	17	75	0	0	92	1	0	19	60	29	0	108	0	1	0	90	79	0	169	0	0	369
4:30:00 PM	0	0	0	0	0	0	0	18	75	0	0	93	0	1	11	54	14	0	79	0	1	0	94	53	0	147	0	0	319
4:45:00 PM	0	0	0	0	0	0	1	20	79	0	0	99	0	0	12	57	13	0	82	0	0	0	85	63	0	148	0	0	329
5:00:00 PM	0	0	0	0	0	0	0	21	69	0	0	90	1	0	14	56	11	0	80	0	0	0	89	74	0	162	0	0	342
Grand Total	0	0	0	0	0	0	0	76	298	0	0	374	2	1	55	236	67	0	359	0	2	0	357	269	0	626	0	0	1389
% Approach	#DIV/0!	#DIV/0!	#DIV/0!	#DIV/0!	0.0%	0.0%	0.0%	14.2%	85.8%	0.0%	0.0%	0.0%	0.0%	0.0%	45.1%	41.7%	13.2%	0.0%	0.0%	0.0%	0.0%	0.0%	66.2%	33.8%	0.0%	0.0%	0.0%	0.0%	
% Total	0.0%	0.0%	0.0%	0.0%	0.0%	0.0%	0.0%	5.6%	21.9%	0.0%	0.0%	27.5%	0.0%	0.0%	4.1%	17.4%	4.9%	0.0%	26.4%	0.0%	0.0%	0.0%	26.3%	19.8%	0.0%	46.1%	0.0%	0.0%	
PHF	0.000	0.000	0.000	0.000	0.000	0.000	0.000	0.905	0.943	0.000	0.000	0.944	0.000	0.000	0.737	0.908	0.578	0.000	0.831	0.000	0.000	0.000	0.949	0.851	0.000	0.926	0.000	0.000	0.921
Lights	0	0	0	0	0	0	0	72	289	0	0	361	0	0	52	224	65	0	341	0	0	0	342	266	0	608	0	0	1310
% Lights	0.0%	0.0%	0.0%	0.0%	0.0%	0.0%	0.0%	94.7%	97.0%	0.0%	0.0%	96.5%	0.0%	0.0%	92.9%	94.9%	97.0%	0.0%	95.0%	0.0%	0.0%	0.0%	95.8%	98.9%	0.0%	97.1%	0.0%	0.0%	96.4%
Trucks	0	0	0	0	0	0	0	0	0	0	0	0	0	0	0	0	0	0	0	0	0	0	0	0	0	0	0	0	0
% Trucks	0.0%	0.0%	0.0%	0.0%	0.0%	0.0%	0.0%	0.0%	0.0%	0.0%	0.0%	0.0%	0.0%	0.0%	0.0%	0.0%	0.0%	0.0%	0.0%	0.0%	0.0%	0.0%	0.0%	0.0%	0.0%	0.0%	0.0%	0.0%	0.0%
Buses	0	0	0	0	0	0	0	4	9	0	0	13	0	0	4	11	2	0	17	0	0	0	13	3	0	16	0	0	46
% Buses	0.0%	0.0%	0.0%	0.0%	0.0%	0.0%	0.0%	5.3%	3.0%	0.0%	0.0%	0.0%	0.0%	0.0%	7.1%	4.7%	3.0%	0.0%	0.0%	0.0%	0.0%	0.0%	3.8%	1.1%	0.0%	0.0%	0.0%	0.0%	3.4%
Pedestrians	0	0	0	0	2	0	0	0	0	0	0	2	1	0	0	0	0	0	2	0	0	0	0	0	0	0	0	0	0
% Pedestrians	0.0%	0.0%	0.0%	0.0%	100.0%	0.0%	0.0%	0.0%	0.0%	0.0%	0.0%	100.0%	100.0%	0.0%	0.0%	0.0%	0.0%	0.0%	0.0%	0.0%	0.0%	0.0%	0.0%	0.0%	0.0%	0.0%	0.0%	0.0%	
Bicycles on Crosswalk	0	0	0	0	0	1	0	0	0	0	0	0	0	0	0	0	0	0	0	0	0	0	0	0	0	0	0	0	0
% Bicycles on Crosswalk	0.0%	0.0%	0.0%	0.0%	0.0%	100.0%	0.0%	0.0%	0.0%	0.0%	0.0%	0.0%	0.0%	0.0%	0.0%	0.0%	0.0%	0.0%	0.0%	0.0%	0.0%	0.0%	0.0%	0.0%	0.0%	0.0%	0.0%	0.0%	

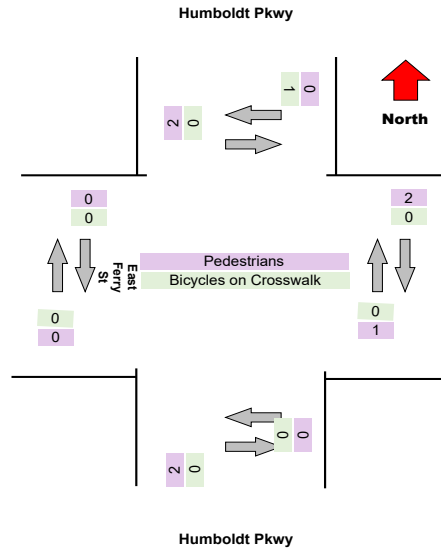
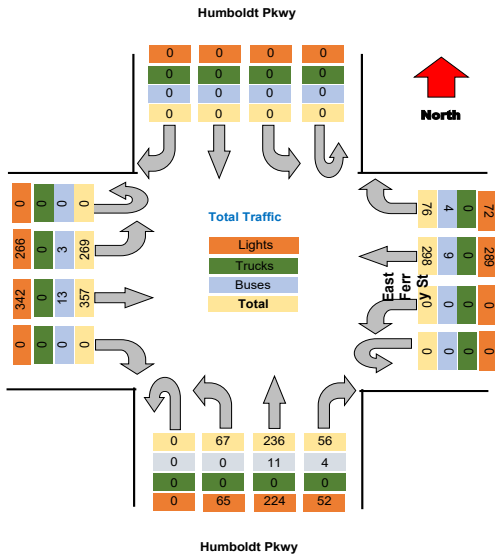

Project : VBH Malta NY
 Site : Site 4
 Location : 42.948550, -73.790036
 Survey Date : 2021-04-28, Wednesday

Turning Movement Data Plot

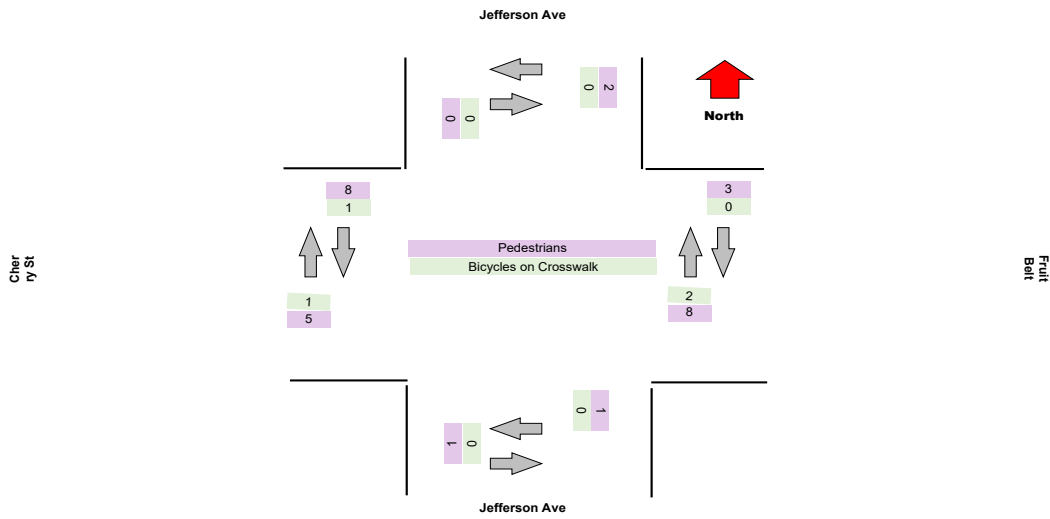
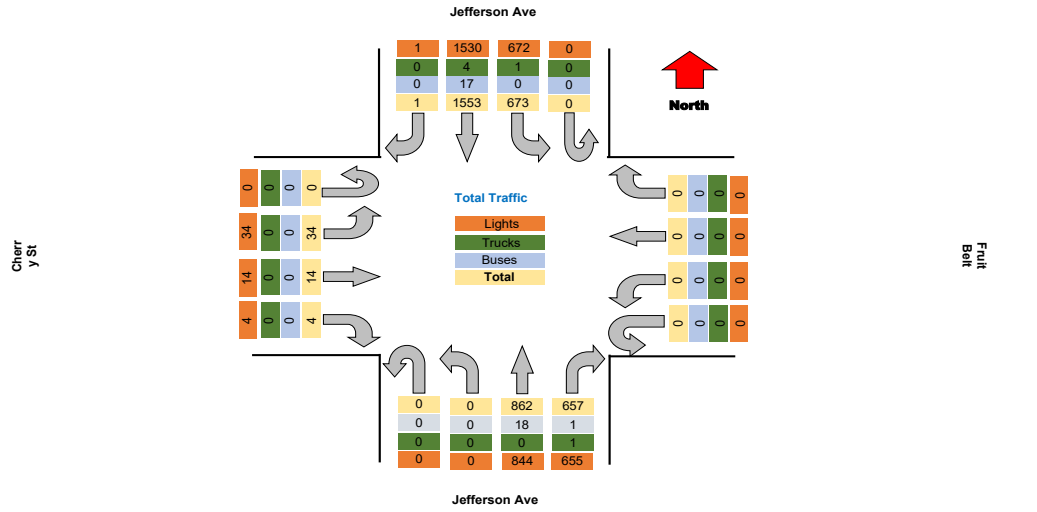

Project : VBH Malta NY
Site : Site 4
Location : 42.948550, -73.790036

TSTData.com

Survey Date : 2021-04-28, Wednesday

Turning Movement Peak Hour Data (AM)

7:30:00 AM

Leg Direction	Jefferson Ave						Fruit Belt						Jefferson Ave						Cherry St						Total				
	Southbound			Northbound			Westbound			Eastbound			Northbound			Eastbound													
Start Time	Right	Thru	Left	U-Turn	App Total	Peds CW	Peds CCW	Right	Thru	Left	U-Turn	App Total	Peds CW	Peds CCW	Right	Thru	Left	U-Turn	App Total	Peds CW	Peds CCW	Right	Thru	Left	U-Turn	App Total	Peds CW	Peds CCW	
7:30:00 AM	0	56	25	0	81	0	0	0	0	0	0	0	0	0	37	57	0	0	94	0	0	0	1	3	0	4	1	1	179
7:45:00 AM	0	73	16	0	89	0	0	0	0	0	0	0	0	0	34	42	0	0	76	0	0	0	0	1	1	0	2	0	167
8:00:00 AM	0	81	20	0	101	0	0	0	0	0	0	0	0	0	31	57	0	0	88	0	0	0	0	1	3	0	4	0	193
8:15:00 AM	0	86	16	0	102	0	0	0	0	0	0	1	1	1	21	41	0	0	64	0	0	0	0	1	3	0	4	0	178
Grand Total	0	296	77	0	373	0	0	0	0	0	0	1	1	1	123	194	0	0	317	0	0	0	4	10	0	14	1	709	
% Approach	0.0%	79.4%	20.6%	0.0%	0.0%	0.0%	0.0%	#DIV/0!	#DIV/0!	#DIV/0!	#DIV/0!	0.0%	0.0%	0.0%	38.2%	61.2%	0.0%	0.0%	0.0%	0.0%	0.0%	0.0%	0.0%	26.6%	71.4%	0.0%	0.0%	0.0%	0.0%
% Total	0.0%	41.7%	10.9%	0.0%	52.6%	0.0%	0.0%	0.0%	0.0%	0.0%	0.0%	0.0%	0.0%	0.0%	17.3%	27.8%	0.0%	0.0%	45.4%	0.0%	0.0%	0.0%	0.0%	0.6%	1.4%	0.0%	2.0%	0.0%	0.0%
PHF	0.000	0.860	0.770	0.000	0.914	0.000	0.000	0.000	0.000	0.000	0.000	0.000	0.000	0.000	0.831	0.864	0.000	0.000	0.856	0.000	0.000	0.000	0.000	1.000	0.833	0.000	0.875	0.000	0.918
Lights	0	290	77	0	367	0	0	0	0	0	0	0	0	0	123	194	0	0	317	0	0	0	4	10	0	14	0	698	
% Lights	0.0%	98.0%	100.0%	0.0%	98.4%	0.0%	0.0%	0.0%	0.0%	0.0%	0.0%	0.0%	0.0%	0.0%	100.0%	98.5%	0.0%	0.0%	98.4%	0.0%	0.0%	0.0%	100.0%	100.0%	0.0%	100.0%	0.0%	98.4%	
Trucks	0	0	0	0	0	0	0	0	0	0	0	0	0	0	0	0	0	0	0	0	0	0	0	0	0	0	0	0	0
% Trucks	0.0%	0.0%	0.0%	0.0%	0.0%	0.0%	0.0%	0.0%	0.0%	0.0%	0.0%	0.0%	0.0%	0.0%	0.0%	0.0%	0.0%	0.0%	0.0%	0.0%	0.0%	0.0%	0.0%	0.0%	0.0%	0.0%	0.0%	0.0%	0.0%
Buses	0	6	0	0	6	0	0	0	0	0	0	0	0	0	3	0	0	0	3	0	0	0	0	0	0	0	0	0	9
% Buses	0.0%	2.0%	0.0%	0.0%	0.0%	0.0%	0.0%	0.0%	0.0%	0.0%	0.0%	0.0%	0.0%	0.0%	0.0%	1.5%	0.0%	0.0%	0.0%	0.0%	0.0%	0.0%	0.0%	0.0%	0.0%	0.0%	0.0%	0.0%	1.3%
Pedestrians	0	0	0	0	0	0	0	0	0	0	1	1	0	0	0	0	0	0	0	0	0	0	0	0	0	0	1	2	0
% Pedestrians	0.0%	0.0%	0.0%	0.0%	0.0%	0.0%	0.0%	0.0%	0.0%	0.0%	100.0%	100.0%	0.0%	0.0%	0.0%	0.0%	0.0%	0.0%	0.0%	0.0%	0.0%	0.0%	0.0%	0.0%	0.0%	0.0%	100.0%	100.0%	0.0%
Bicycles on Crosswalk	0	0	0	0	0	0	0	0	0	0	0	0	0	0	0	0	0	0	0	0	0	0	0	0	0	0	0	0	0
% Bicycles on Crosswalk	0.0%	0.0%	0.0%	0.0%	0.0%	0.0%	0.0%	0.0%	0.0%	0.0%	0.0%	0.0%	0.0%	0.0%	0.0%	0.0%	0.0%	0.0%	0.0%	0.0%	0.0%	0.0%	0.0%	0.0%	0.0%	0.0%	0.0%	0.0%	0.0%

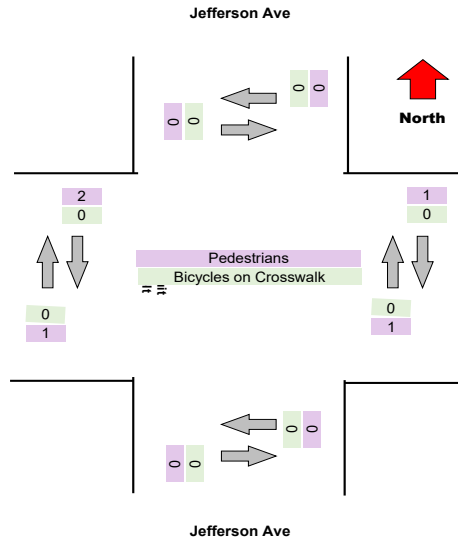
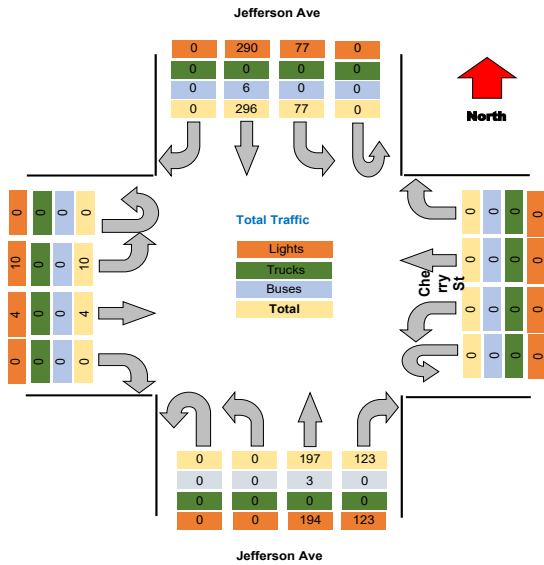

Project : VBH Malta NY
 Site : Site 4
 Location : 42.948550, -73.790036
 Survey Date : 2021-04-28, Wednesday

TSTData.com

Turning Movement Peak Hour Data (PM)

4:15:00 PM

Leg Direction	Jefferson Ave						Fruit Belt						Jefferson Ave						Cherry St						Total					
	Southbound			Northbound			Westbound			Eastbound			Northbound			Eastbound														
Start Time	Right	Thru	Left	U-Turn	App Total	Peds CW	Peds CCW	Right	Thru	Left	U-Turn	App Total	Peds CW	Peds CCW	Right	Thru	Left	U-Turn	App Total	Peds CW	Peds CCW	Right	Thru	Left	U-Turn	App Total	Peds CW	Peds CCW		
4:15:00 PM	0	134	72	0	206	0	1	0	0	0	0	0	1	1	65	53	0	0	118	1	0	0	1	1	0	0	2	1	1	326
4:30:00 PM	1	147	80	0	228	0	0	0	0	0	0	0	2	2	62	53	0	0	115	0	0	0	0	0	5	0	5	0	0	348
4:45:00 PM	0	137	69	0	206	0	1	0	0	0	0	0	0	0	44	70	0	0	114	0	0	0	0	0	4	0	4	2	1	324
5:00:00 PM	0	117	83	0	200	0	0	0	0	0	0	0	0	0	64	81	0	0	145	0	0	0	0	0	2	0	2	0	0	347
Grand Total	1	535	304	0	840	0	2	0	0	0	0	0	1	5	235	257	0	0	492	1	0	1	1	11	0	13	3	2	1345	
% Approach	0.1%	63.7%	36.2%	0.0%	0.0%	0.0%	0.0%	#DIV/0!	#DIV/0!	#DIV/0!	#DIV/0!	0.0%	0.0%	0.0%	47.6%	52.2%	0.0%	0.0%	0.0%	0.0%	0.0%	0.0%	7.7%	7.7%	84.6%	0.0%	0.0%	0.0%	0.0%	0.0%
% Total	0.1%	39.8%	22.6%	0.0%	62.5%	0.0%	0.0%	0.0%	0.0%	0.0%	0.0%	0.0%	0.0%	0.0%	17.5%	19.1%	0.0%	0.0%	36.6%	0.0%	0.0%	0.1%	0.1%	0.8%	0.0%	1.0%	0.0%	0.0%	0.7%	
PHF	0.250	0.910	0.916	0.000	0.921	0.000	0.000	0.000	0.000	0.000	0.000	0.000	0.000	0.000	0.904	0.793	0.000	0.000	0.848	0.000	0.000	0.250	0.250	0.550	0.000	0.650	0.000	0.000	0.966	
Lights	1	528	304	0	833	0	0	0	0	0	0	0	0	0	235	252	0	0	487	0	0	1	1	11	0	13	0	0	1333	
% Lights	100.0%	98.7%	100.0%	0.0%	99.2%	0.0%	0.0%	0.0%	0.0%	0.0%	0.0%	0.0%	0.0%	0.0%	100.0%	98.1%	0.0%	0.0%	99.0%	0.0%	0.0%	100.0%	100.0%	100.0%	0.0%	100.0%	0.0%	0.0%	99.1%	
Trucks	0	1	0	0	1	0	0	0	0	0	0	0	0	0	0	0	0	0	0	0	0	0	0	0	0	0	0	0	0	1
% Trucks	0.0%	0.2%	0.0%	0.0%	0.1%	0.0%	0.0%	0.0%	0.0%	0.0%	0.0%	0.0%	0.0%	0.0%	0.0%	0.0%	0.0%	0.0%	0.0%	0.0%	0.0%	0.0%	0.0%	0.0%	0.0%	0.0%	0.0%	0.0%	0.1%	
Buses	0	4	0	0	4	0	0	0	0	0	0	0	0	0	0	5	0	0	5	0	0	0	0	0	0	0	0	0	0	9
% Buses	0.0%	0.7%	0.0%	0.0%	0.0%	0.0%	0.0%	0.0%	0.0%	0.0%	0.0%	0.0%	0.0%	0.0%	0.0%	1.9%	0.0%	0.0%	0.0%	0.0%	0.0%	0.0%	0.0%	0.0%	0.0%	0.0%	0.0%	0.0%	0.7%	
Pedestrians	0	0	0	0	0	0	2	0	0	0	0	1	5	0	0	0	0	0	1	0	0	0	0	0	0	0	0	2	1	0
% Pedestrians	0.0%	0.0%	0.0%	0.0%	0.0%	0.0%	100.0%	0.0%	0.0%	0.0%	0.0%	100.0%	100.0%	0.0%	0.0%	0.0%	0.0%	0.0%	0.0%	0.0%	100.0%	0.0%	0.0%	0.0%	0.0%	0.0%	0.0%	66.7%	50.0%	0.0%
Bicycles on Crosswalk	0	0	0	0	0	0	0	0	0	0	0	0	0	0	0	0	0	0	0	0	0	0	0	0	0	0	1	1	0	
% Bicycles on Crosswalk	0.0%	0.0%	0.0%	0.0%	0.0%	0.0%	0.0%	0.0%	0.0%	0.0%	0.0%	0.0%	0.0%	0.0%	0.0%	0.0%	0.0%	0.0%	0.0%	0.0%	0.0%	0.0%	0.0%	0.0%	0.0%	0.0%	33.3%	50.0%	0.0%	

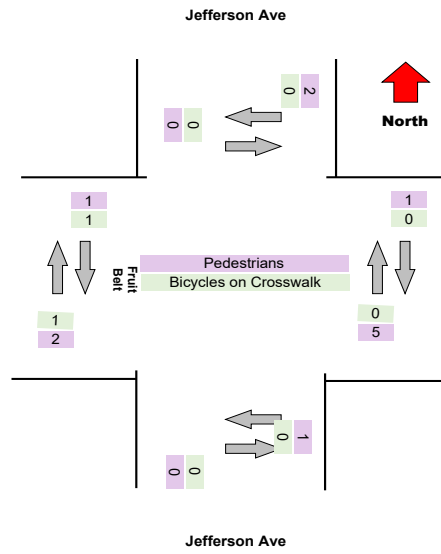
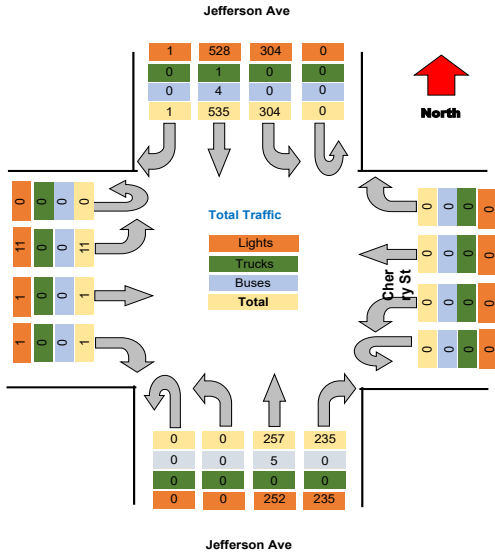

Project : VBH Malta NY
Site : Site 4
Location : 42.948550, -73.790036

TSTData.com

Survey Date : 2021-04-28, Wednesday

Project	LaBella
Project Code	LaBella
Site Name	10
Legs and Movements	All Processed Legs & Move
Bin Size	15 minutes
Survey Date	2021-11-03, Wednesday
Location	10
Latitude and Longitude	42.896936, -78.853849

	Start	End	PHF
Forced Peak AM	2021/11/03 07:30:00	2021/11/03 08:30:00	0.93
Forced Peak PM	2021/11/03 16:30:00	2021/11/03 17:30:00	0.96
AM Peak	2021/11/03 07:30:00	2021/11/03 08:30:00	0.93
PM Peak	2021/11/03 16:15:00	2021/11/03 17:15:00	0.92

Turning Movement Data

Leg Direction	Jefferson Ave										Fruit Belt										Jefferson Ave										Cherry St										Total
	Southbound					Westbound					Northbound					Eastbound					Southbound					Westbound															
	Right	Thru	Left	U-Turn	App Total	Right	Thru	Left	U-Turn	App Total	Right	Thru	Left	U-Turn	App Total	Right	Thru	Left	U-Turn	App Total	Right	Thru	Left	U-Turn	App Total	Right	Thru	Left	U-Turn	App Total	Right	Thru	Left	U-Turn	App Total						
6:30:00 AM	0	38	16	0	54	0	0	0	0	0	12	37	0	0	49	0	0	0	0	0	0	1	5	0	6	0	0	0	0	0	0	0	0	0	0	109					
6:45:00 AM	0	58	20	0	78	0	0	0	0	0	23	47	0	0	70	0	0	0	0	0	0	1	1	0	2	0	0	0	0	0	0	0	0	0	0	150					
Hourly Total	0	96	36	0	132	0	0	0	0	0	35	84	0	0	119	0	0	0	0	0	0	2	6	0	8	0	0	0	0	0	0	0	0	0	0	259					
7:00:00 AM	0	56	28	0	84	0	0	0	0	0	23	50	0	0	73	0	0	0	0	0	0	3	3	0	6	0	0	0	0	0	0	0	0	0	0	163					
7:15:00 AM	0	72	17	0	89	0	0	0	0	0	37	57	0	0	94	0	0	0	0	0	0	0	2	0	2	0	1	0	0	1	0	0	0	0	0	185					
7:30:00 AM	0	96	31	0	127	0	0	0	0	0	52	77	0	0	129	0	0	0	0	0	0	1	3	0	4	0	0	0	0	0	0	0	0	0	0	260					
7:45:00 AM	0	110	35	0	145	0	0	0	0	0	47	96	0	0	144	0	0	0	0	0	0	0	2	0	2	0	0	0	0	0	0	0	0	0	0	291					
Hourly Total	0	334	111	0	445	0	0	0	0	0	159	280	0	0	440	0	0	0	0	0	0	4	10	0	14	0	0	0	0	0	0	0	0	0	0	899					
8:00:00 AM	0	142	36	0	178	0	0	0	0	0	38	71	0	0	109	0	0	0	0	0	0	3	3	0	6	0	0	0	0	0	0	0	0	0	0	293					
8:15:00 AM	0	120	21	0	141	0	0	0	0	0	45	55	0	0	100	0	0	0	0	0	0	2	3	0	5	0	0	0	0	0	0	0	0	0	0	246					
Hourly Total	0	262	57	0	319	0	0	0	0	0	83	126	0	0	209	0	0	0	0	0	0	5	6	0	11	0	0	0	0	0	0	0	0	0	0	539					
4:00:00 PM	0	157	74	0	231	0	0	0	0	0	78	83	0	0	161	0	0	0	0	0	0	2	4	0	6	1	0	0	0	0	0	0	0	0	0	398					
4:15:00 PM	0	166	79	0	245	0	0	0	0	0	80	72	0	0	152	0	0	0	0	0	0	4	6	0	10	3	1	0	0	0	0	0	0	0	0	407					
4:30:00 PM	0	153	76	0	229	0	0	0	0	0	67	78	0	0	145	0	0	0	0	0	0	2	2	0	4	0	0	0	0	0	0	0	0	0	0	378					
4:45:00 PM	0	153	63	0	216	0	0	0	0	0	57	77	0	0	134	0	0	0	0	0	1	2	0	0	3	0	0	0	0	0	0	0	0	0	0	353					
Hourly Total	0	629	292	0	921	0	0	0	0	0	262	310	0	0	572	0	0	0	0	0	1	10	12	0	23	4	1	0	0	0	0	0	0	0	0	1536					
5:00:00 PM	0	134	65	0	199	0	0	0	0	0	72	84	0	0	156	0	0	0	0	0	0	0	3	0	3	0	0	0	0	0	0	0	0	0	0	358					
5:15:00 PM	0	158	73	0	231	0	0	0	0	0	47	72	0	0	119	0	0	0	0	0	0	1	4	0	5	2	1	0	0	0	0	0	0	0	0	355					
5:30:00 PM	0	121	42	0	163	0	0	0	0	0	69	68	0	0	137	1	0	0	0	0	0	1	4	0	5	1	1	0	0	0	0	0	0	0	0	305					
5:45:00 PM	1	120	44	0	165	0	0	0	0	0	51	52	0	0	103	0	0	0	0	0	1	1	5	0	7	0	0	0	0	0	0	0	0	0	0	275					
Hourly Total	1	533	224	0	758	0	0	0	0	0	239	276	0	0	515	1	0	0	0	0	1	3	16	0	20	3	2	0	0	0	0	0	0	0	0	1293					
Grand Total	1	1854	720	0	2575	0	0	0	0	0	798	1076	0	0	1875	1	1	0	0	0	2	24	50	0	76	8	13	0	0	0	0	0	0	0	0	4526					
% Approach	0.0%	72.0%	28.0%	0.0%	0.0%	0.0%	0.0%	0.0%	0.0%	0.0%	42.6%	57.4%	0.0%	0.0%	0.0%	0.0%	0.0%	0.0%	0.0%	0.0%	2.6%	31.6%	65.8%	0.0%	0.0%	0.0%	0.0%	0.0%	0.0%	0.0%	0.0%	0.0%	0.0%	0.0%	0.0%	0.0%					
% Total	0.0%	41.0%	15.9%	0.0%	56.9%	0.0%	0.0%	0.0%	0.0%	0.0%	17.6%	23.8%	0.0%	0.0%	41.4%	0.0%	0.0%	0.0%	0.0%	0.0%	0.0%	0.5%	1.1%	0.0%	1.7%	0.0%	0.0%	0.0%	0.0%	0.0%	0.0%	0.0%	0.0%	0.0%	0.0%	0.0%					
Lights	1	1779	720	0	2500	0	0	0	0	0	786	1024	0	0	1810	0	0	0	0	0	2	24	48	0	74	0	0	0	0	0	0	0	0	0	0	4384					
% Lights	100.0%	96.0%	100.0%	0.0%	97.1%	0.0%	0.0%	0.0%	0.0%	0.0%	88.5%	85.2%	0.0%	0.0%	96.5%	0.0%	0.0%	0.0%	0.0%	0.0%	100.0%	100.0%	96.0%	0.0%	97.4%	0.0%	0.0%	0.0%	0.0%	0.0%	0.0%	0.0%	0.0%	0.0%	0.0%	96.9%					
Trucks	0	3	0	0	3	0	0	0	0	0	2	1	0	0	3	0	0	0	0	0	0	0	0	0	0	0	0	0	0	0	0	0	0	0	0	6					
% Trucks	0.0%	0.2%	0.0%	0.0%	0.1%	0.0%	0.0%	0.0%	0.0%	0.0%	0.3%	0.1%	0.0%	0.0%	0.2%	0.0%	0.0%	0.0%	0.0%	0.0%	0.0%	0.0%	0.0%	0.0%	0.0%	0.0%	0.0%	0.0%	0.0%	0.0%	0.0%	0.0%	0.0%	0.0%	0.0%	0.1%					
Buses	0	72	0	0	72	0	0	0	0	0	10	51	0	0	61	0	0	0	0	0	0	0	2	0	2	0	0	0	0	0	0	0	0	0	0	135					
% Buses	0.0%	3.9%	0.0%	0.0%	0.0%	0.0%	0.0%	0.0%	0.0%	0.0%	1.3%	4.7%	0.0%	0.0%	0.0%	0.0%	0.0%	0.0%	0.0%	0.0%	0.0%	0.0%	4.0%	0.0%	0.0%	0.0%	0.0%	0.0%	0.0%	0.0%	0.0%	0.0%	0.0%	0.0%	0.0%	3.0%					
Pedestrians	0	0	0	0	0	0	0	0	0	0	0	0	0	0	0	1	1	0	0	0	0	0	0	0	0	0	0	0	0	0	0	0	0	0	0	12					
% Pedestrians	0.0%	0.0%	0.0%	0.0%	0.0%	0.0%	0.0%	0.0%	0.0%	0.0%	0.0%	0.0%	0.0%	0.0%	0.0%	100.0%	100.0%	0.0%	0.0%	0.0%	0.0%	0.0%	0.0%	0.0%	0.0%	0.0%	0.0%	0.0%	0.0%	0.0%	75.0%	92.3%	0.0%	0.0%	0.0%	0.0%					
Bicycles on Crosswalk	0	0	0	0	0	0	0	0	0	0	0	0	0	0	0	0	0	0	0	0	0	0	0	0	0	0	0	0	0	0	0	0	0	0	0	1					
% Bicycles on Crosswalk	0.0%	0.0%	0.0%	0.0%	0.0%	0.0%	0.0%	0.0%	0.0%	0.0%	0.0%	0.0%	0.0%	0.0%	0.0%	0.0%	0.0%	0.0%	0.0%	0.0%	0.0%	0.0%	0.0%	0.0%	0.0%	0.0%	0.0%	0.0%	0.0%	0.0%	0.0%	25.0%	7.7%	0.0%	0.0%	0.0%					

Project : VBH Malta NY
 Site : Site 4
 Location : 42.948550, -73.790036
 Survey Date : 2021-04-28, Wednesday

Turning Movement Data Plot

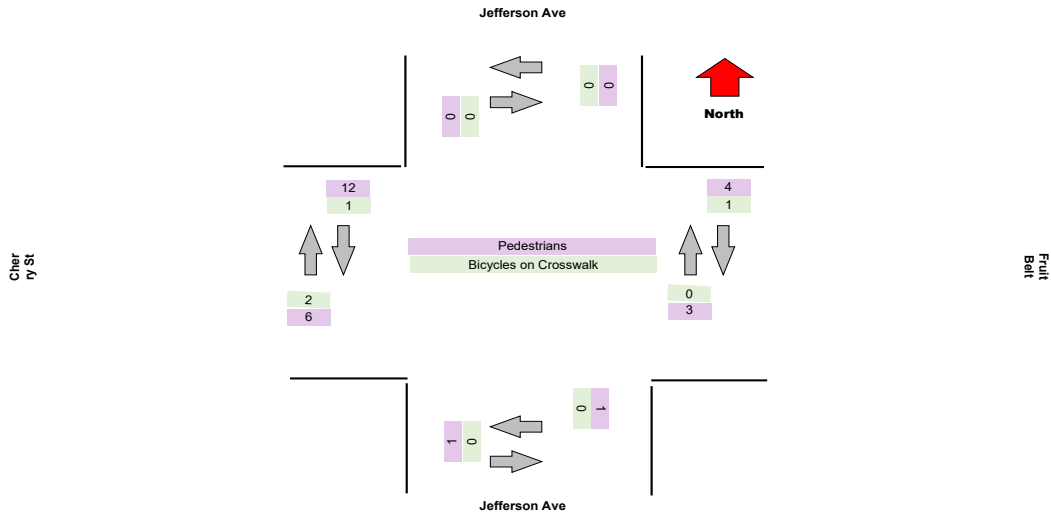
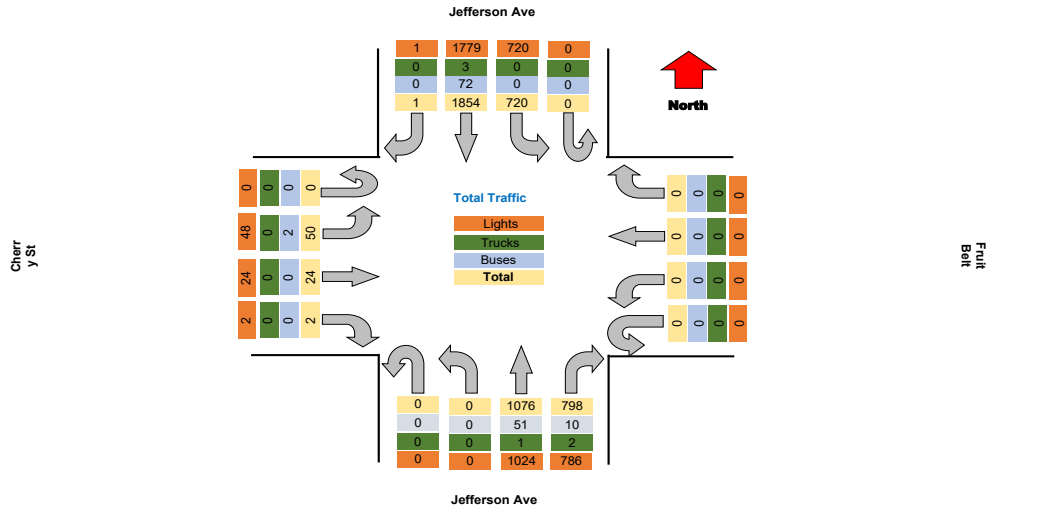

Project : VBH Malta NY
Site : Site 4
Location : 42.948550, -73.790036

TSTData.com

Survey Date : 2021-04-28, Wednesday

Turning Movement Peak Hour Data (AM)

7:30:00 AM

Leg Direction	Jefferson Ave				Fruit Belt				Jefferson Ave				Cherry St				Total						
	Southbound		Northbound		Westbound		Eastbound		Northbound		Eastbound		Westbound										
Start Time	Right	Thru	Left	U-Turn	App Total	Peds CW	Peds CCW	Right	Thru	Left	U-Turn	App Total	Peds CW	Peds CCW	Right	Thru	Left	U-Turn	App Total	Peds CW	Peds CCW		
7:30:00 AM	0	96	31	0	127	0	0	0	0	0	0	0	0	0	52	77	0	0	129	0	0	260	
7:45:00 AM	0	110	35	0	145	0	0	0	0	0	0	1	47	96	0	0	0	0	144	0	0	291	
8:00:00 AM	0	142	36	0	178	0	0	0	0	0	0	0	38	71	0	0	0	0	109	0	0	293	
8:15:00 AM	0	120	21	0	141	0	0	0	0	0	0	0	45	55	0	0	0	0	100	0	0	246	
Grand Total	0	468	123	0	591	0	0	0	0	0	0	1	182	299	0	0	0	0	482	0	0	1099	
% Approach	0.0%	79.2%	20.8%	0.0%	0.0%	0.0%	0.0%	#DIV/0!	#DIV/0!	#DIV/0!	#DIV/0!	0.0%	0.0%	0.0%	37.8%	82.0%	0.0%	0.0%	0.0%	0.0%	0.0%	0.0%	0.0%
% Total	0.0%	42.9%	11.3%	0.0%	54.2%	0.0%	0.0%	0.0%	0.0%	0.0%	0.0%	0.0%	0.0%	0.0%	16.7%	27.4%	0.0%	0.0%	44.2%	0.0%	0.0%	0.0%	0.0%
PHF	0.000	0.824	0.854	0.000	0.830	0.000	0.000	0.000	0.000	0.000	0.000	0.000	0.875	0.779	0.000	0.000	0.837	0.000	0.000	0.000	0.000	0.000	0.930
Lights	0	433	123	0	556	0	0	0	0	0	0	0	175	277	0	0	0	0	452	0	0	1024	
% Lights	0.0%	82.5%	100.0%	0.0%	94.1%	0.0%	0.0%	0.0%	0.0%	0.0%	0.0%	0.0%	98.2%	92.6%	0.0%	0.0%	0.0%	0.0%	93.8%	0.0%	0.0%	94.1%	
Trucks	0	2	0	0	2	0	0	0	0	0	0	0	2	0	0	0	0	0	2	0	0	4	
% Trucks	0.0%	0.4%	0.0%	0.0%	0.3%	0.0%	0.0%	0.0%	0.0%	0.0%	0.0%	0.0%	1.1%	0.0%	0.0%	0.0%	0.0%	0.4%	0.0%	0.0%	0.0%	0.4%	
Buses	0	33	0	0	33	0	0	0	0	0	0	0	5	22	0	0	0	0	27	0	0	61	
% Buses	0.0%	7.1%	0.0%	0.0%	0.0%	0.0%	0.0%	0.0%	0.0%	0.0%	0.0%	0.0%	2.7%	7.4%	0.0%	0.0%	0.0%	0.0%	0.0%	0.0%	0.0%	5.6%	
Pedestrians	0	0	0	0	0	0	0	0	0	0	0	1	0	0	0	0	0	0	0	0	0	2	
% Pedestrians	0.0%	0.0%	0.0%	0.0%	0.0%	0.0%	0.0%	0.0%	0.0%	0.0%	0.0%	0.0%	0.0%	0.0%	0.0%	0.0%	0.0%	0.0%	0.0%	0.0%	0.0%	100.0%	
Bicycles on Crosswalk	0	0	0	0	0	0	0	0	0	0	0	0	0	0	0	0	0	0	0	0	0	0	
% Bicycles on Crosswalk	0.0%	0.0%	0.0%	0.0%	0.0%	0.0%	0.0%	0.0%	0.0%	0.0%	0.0%	0.0%	0.0%	0.0%	0.0%	0.0%	0.0%	0.0%	0.0%	0.0%	0.0%	0.0%	

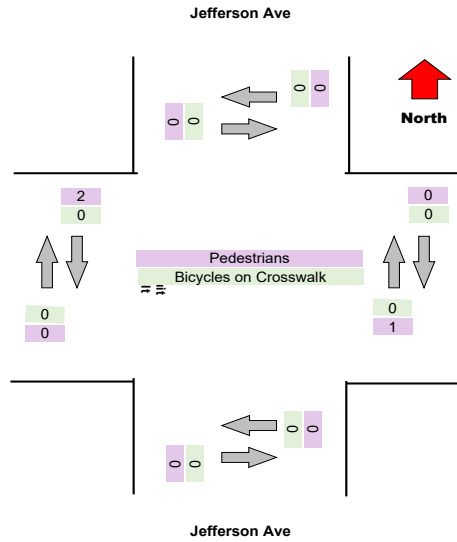
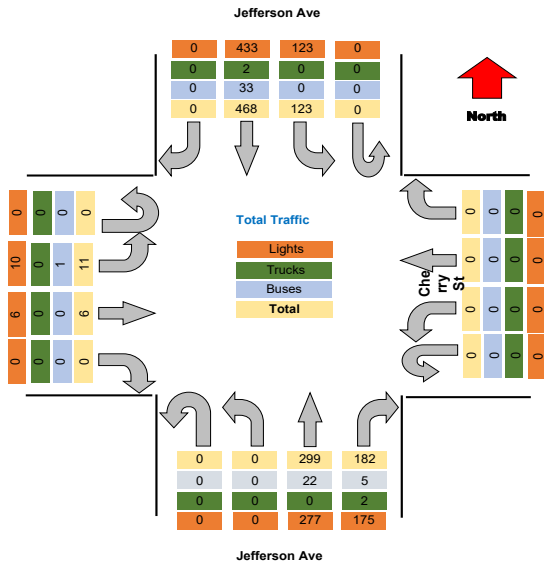

Turning Movement Peak Hour Data (PM)

4:15:00 PM

Leg Direction	Jefferson Ave						Fruit Belt						Jefferson Ave						Cherry St						Total					
	Southbound			Northbound			Westbound			Eastbound			Northbound			Eastbound														
Start Time	Right	Thru	Left	U-Turn	App Total	Peds CW	Peds CCW	Right	Thru	Left	U-Turn	App Total	Peds CW	Peds CCW	Right	Thru	Left	U-Turn	App Total	Peds CW	Peds CCW	Right	Thru	Left	U-Turn	App Total	Peds CW	Peds CCW		
4:15:00 PM	0	166	79	0	245	0	0	0	0	0	0	0	0	1	80	72	0	0	152	0	0	0	4	6	0	10	3	1	407	
4:30:00 PM	0	153	76	0	229	0	0	0	0	0	0	0	0	0	67	78	0	0	145	0	0	0	2	2	0	4	0	0	378	
4:45:00 PM	0	153	63	0	216	0	0	0	0	0	0	0	1	0	57	77	0	0	134	0	0	1	2	0	3	0	0	353		
5:00:00 PM	0	134	45	0	179	0	0	0	0	0	0	0	1	0	72	84	0	0	156	0	0	0	0	3	0	3	0	358		
Grand Total	0	636	263	0	899	0	0	0	0	0	0	2	1	0	276	311	0	0	587	0	0	1	8	11	0	20	3	1	1488	
% Approach	0.0%	68.2%	31.8%	0.0%	0.0%	0.0%	0.0%	#DIV/0!	#DIV/0!	#DIV/0!	#DIV/0!	0.0%	0.0%	0.0%	47.0%	53.0%	0.0%	0.0%	0.0%	0.0%	0.0%	0.0%	5.0%	40.0%	55.0%	0.0%	0.0%	0.0%	0.0%	
% Total	0.0%	40.5%	18.9%	0.0%	59.4%	0.0%	0.0%	0.0%	0.0%	0.0%	0.0%	0.0%	0.0%	0.0%	18.4%	20.8%	0.0%	0.0%	39.2%	0.0%	0.0%	0.1%	0.5%	0.7%	0.0%	1.3%	0.0%	0.0%	0.0%	
PHF	0.000	0.913	0.896	0.000	0.907	0.000	0.000	0.000	0.000	0.000	0.000	0.000	0.000	0.000	0.863	0.926	0.000	0.000	0.841	0.000	0.000	0.250	0.500	0.458	0.000	0.500	0.000	0.000	0.919	
Lights	0	589	283	0	872	0	0	0	0	0	0	0	0	0	273	301	0	0	574	0	0	1	8	11	0	20	0	0	1466	
% Lights	0.0%	97.2%	100.0%	0.0%	98.1%	0.0%	0.0%	0.0%	0.0%	0.0%	0.0%	0.0%	0.0%	0.0%	98.9%	96.8%	0.0%	0.0%	97.8%	0.0%	0.0%	100.0%	100.0%	100.0%	0.0%	100.0%	0.0%	0.0%	98.0%	
Trucks	0	0	0	0	0	0	0	0	0	0	0	0	0	0	0	0	0	0	0	0	0	0	0	0	0	0	0	0	0	
% Trucks	0.0%	0.0%	0.0%	0.0%	0.0%	0.0%	0.0%	0.0%	0.0%	0.0%	0.0%	0.0%	0.0%	0.0%	0.0%	0.0%	0.0%	0.0%	0.0%	0.0%	0.0%	0.0%	0.0%	0.0%	0.0%	0.0%	0.0%	0.0%	0.0%	
Buses	0	17	0	0	17	0	0	0	0	0	0	0	0	0	3	10	0	0	13	0	0	0	0	0	0	0	0	0	30	
% Buses	0.0%	2.8%	0.0%	0.0%	0.0%	0.0%	0.0%	0.0%	0.0%	0.0%	0.0%	0.0%	0.0%	0.0%	1.1%	3.2%	0.0%	0.0%	0.0%	0.0%	0.0%	0.0%	0.0%	0.0%	0.0%	0.0%	0.0%	0.0%	2.0%	
Pedestrians	0	0	0	0	0	0	0	0	0	0	2	1	0	0	0	0	0	0	0	0	0	0	0	0	0	0	1	1	0	
% Pedestrians	0.0%	0.0%	0.0%	0.0%	0.0%	0.0%	0.0%	0.0%	0.0%	0.0%	100.0%	100.0%	0.0%	0.0%	0.0%	0.0%	0.0%	0.0%	0.0%	0.0%	0.0%	0.0%	0.0%	0.0%	0.0%	0.0%	0.0%	33.3%	100.0%	0.0%
Bicycles on Crosswalk	0	0	0	0	0	0	0	0	0	0	0	0	0	0	0	0	0	0	0	0	0	0	0	0	0	0	2	0	0	
% Bicycles on Crosswalk	0.0%	0.0%	0.0%	0.0%	0.0%	0.0%	0.0%	0.0%	0.0%	0.0%	0.0%	0.0%	0.0%	0.0%	0.0%	0.0%	0.0%	0.0%	0.0%	0.0%	0.0%	0.0%	0.0%	0.0%	0.0%	0.0%	66.7%	0.0%	0.0%	

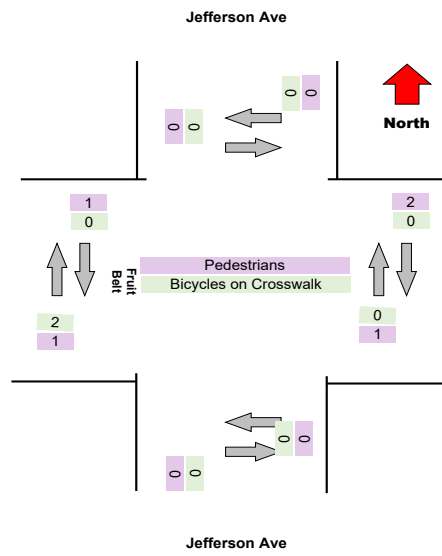
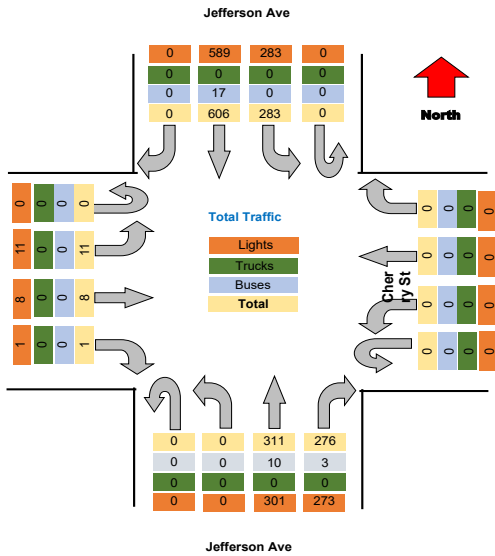

Project : VBH Malta NY
 Site : Site 4
 Location : 42.948550, -73.790036

TSTData.com

Survey Date : 2021-04-28, Wednesday

Project	LaBella
Project Code	LaBella
Site Name	10
Legs and Movements	All Processed Legs & Move
Bin Size	15 minutes
Survey Date	2021-11-04, Thursday
Location	10
Latitude and Longitude	42.896936, -78.853849

	Start	End	PHF
Forced Peak AM	2021/11/04 07:30:00	2021/11/04 08:30:00	0.92
Forced Peak PM	2021/11/04 16:30:00	2021/11/04 17:30:00	0.96
AM Peak	2021/11/04 07:30:00	2021/11/04 08:30:00	0.92
PM Peak	2021/11/04 16:15:00	2021/11/04 17:15:00	0.94

Turning Movement Data

Leg Direction	Jefferson Ave										Fruit Belt										Jefferson Ave										Cherry St										Total
	Southbound					Westbound					Northbound					Eastbound					Northbound					Eastbound															
	Right	Thru	Left	U-Turn	App Total	Right	Thru	Left	U-Turn	App Total	Right	Thru	Left	U-Turn	App Total	Right	Thru	Left	U-Turn	App Total	Right	Thru	Left	U-Turn	App Total	Right	Thru	Left	U-Turn	App Total											
6:30:00 AM	0	46	11	0	57	0	0	0	0	0	27	31	0	0	58	0	0	0	0	0	0	0	0	0	0	0	0	0	0	0	0	0	0	0	0	115					
6:45:00 AM	0	58	11	0	69	0	0	0	0	0	20	50	0	0	70	0	0	0	0	0	0	1	2	0	3	0	0	0	0	0	0	0	0	0	0	142					
Hourly Total	0	104	22	0	126	0	0	0	0	0	47	81	0	0	128	0	0	0	0	0	0	1	2	0	3	0	0	0	0	0	0	0	0	0	0	257					
7:00:00 AM	0	50	25	0	75	0	0	0	0	0	29	40	0	0	69	0	0	0	0	0	0	1	2	0	3	0	0	0	0	0	0	0	0	0	0	147					
7:15:00 AM	0	65	16	0	81	0	0	0	0	0	30	56	0	0	86	0	0	0	0	0	0	0	2	0	2	0	0	0	0	0	0	0	0	0	0	169					
7:30:00 AM	0	94	30	0	124	0	0	0	0	0	37	76	0	0	113	0	0	0	0	0	0	3	2	0	5	0	0	0	0	0	0	0	0	0	0	242					
7:45:00 AM	0	109	34	0	143	0	0	0	0	0	40	102	0	0	142	0	0	0	0	0	0	0	4	0	4	0	0	0	0	0	0	0	0	0	0	289					
Hourly Total	0	318	105	0	423	0	0	0	0	0	136	274	0	0	410	0	0	0	0	0	0	4	10	0	14	0	0	0	0	0	0	0	0	0	0	847					
8:00:00 AM	0	104	32	0	136	0	0	0	0	0	41	89	0	0	131	0	0	0	0	0	0	1	5	0	6	0	0	0	0	0	0	0	0	0	0	273					
8:15:00 AM	0	125	28	0	153	0	0	0	0	0	35	63	0	0	99	0	0	0	0	0	0	0	2	0	2	0	0	0	0	0	0	0	0	0	0	254					
Hourly Total	0	229	60	0	289	0	0	0	0	0	76	152	0	0	230	0	0	0	0	0	0	1	7	0	8	0	0	0	0	0	0	0	0	0	0	527					
4:00:00 PM	0	185	96	0	281	0	0	0	0	0	58	48	0	0	106	0	0	0	0	0	1	2	3	0	6	1	0	0	0	0	0	0	0	0	0	393					
4:15:00 PM	0	169	72	0	241	0	0	0	0	0	62	80	0	0	142	0	0	0	0	0	0	1	3	0	4	0	0	0	0	0	0	0	0	0	0	387					
4:30:00 PM	0	129	70	0	199	0	0	0	0	0	81	76	0	0	157	0	0	0	0	0	0	1	5	0	6	0	0	0	0	0	0	0	0	0	0	362					
4:45:00 PM	0	146	65	0	211	0	0	0	0	0	65	68	0	0	133	0	0	0	0	0	0	2	2	0	4	0	0	0	0	0	0	0	0	0	0	348					
Hourly Total	0	629	303	0	932	0	0	0	0	0	266	272	0	0	538	0	0	0	0	0	1	6	13	0	20	0	0	0	0	0	0	0	0	0	0	1490					
5:00:00 PM	0	135	76	0	211	0	0	0	0	0	70	73	0	0	143	0	0	0	0	0	0	0	3	0	3	1	0	0	0	0	0	0	0	0	0	357					
5:15:00 PM	0	134	58	0	192	0	0	0	0	0	46	77	0	0	123	0	0	0	0	0	0	3	4	0	7	0	0	0	0	0	0	0	0	0	0	322					
5:30:00 PM	0	116	50	0	166	0	0	0	0	0	56	73	0	0	129	0	0	0	0	0	2	2	3	0	7	0	0	0	0	0	0	0	0	0	0	302					
5:45:00 PM	0	134	36	0	170	0	0	0	0	0	46	70	0	0	116	0	0	0	0	0	0	2	2	0	4	0	0	0	0	0	0	0	0	0	0	290					
Hourly Total	0	519	220	0	739	0	0	0	0	0	218	293	0	0	511	0	0	0	0	0	2	7	12	0	21	1	0	0	0	0	0	0	0	0	0	1271					
Grand Total	0	1799	710	0	2509	0	0	0	0	0	743	1072	0	0	1817	0	0	0	0	0	3	19	44	0	66	5	0	0	0	0	0	0	0	0	0	4392					
% Approach	0.0%	71.7%	28.3%	0.0%	0.0%	0.0%	0.0%	0.0%	0.0%	0.0%	40.9%	59.0%	0.0%	0.0%	0.0%	0.0%	0.0%	0.0%	0.0%	0.0%	4.5%	28.8%	66.7%	0.0%	0.0%	0.0%	0.0%	0.0%	0.0%	0.0%	0.0%	0.0%	0.0%	0.0%	0.0%	0.0%					
% Total	0.0%	41.0%	16.2%	0.0%	57.1%	0.0%	0.0%	0.0%	0.0%	0.0%	16.9%	24.4%	0.0%	0.0%	41.4%	0.0%	0.0%	0.0%	0.0%	0.0%	0.1%	0.4%	1.0%	0.0%	1.5%	0.0%	0.0%	0.0%	0.0%	0.0%	0.0%	0.0%	0.0%	0.0%	0.0%	0.0%					
Lights	0	1728	708	0	2436	0	0	0	0	0	733	1020	0	0	1753	0	0	0	0	0	2	19	42	0	63	0	0	0	0	0	0	0	0	0	0	4252					
% Lights	0.0%	96.1%	99.7%	0.0%	97.1%	0.0%	0.0%	0.0%	0.0%	0.0%	88.7%	95.1%	0.0%	0.0%	96.8%	0.0%	0.0%	0.0%	0.0%	0.0%	66.7%	100.0%	95.5%	0.0%	95.5%	0.0%	0.0%	0.0%	0.0%	0.0%	0.0%	0.0%	0.0%	0.0%	0.0%	96.8%					
Trucks	0	0	0	0	0	0	0	0	0	0	1	4	0	0	5	0	0	0	0	0	0	0	0	0	0	0	0	0	0	0	0	0	0	0	0	5					
% Trucks	0.0%	0.0%	0.0%	0.0%	0.0%	0.0%	0.0%	0.0%	0.0%	0.0%	0.1%	0.4%	0.0%	0.0%	0.3%	0.0%	0.0%	0.0%	0.0%	0.0%	0.0%	0.0%	0.0%	0.0%	0.0%	0.0%	0.0%	0.0%	0.0%	0.0%	0.0%	0.0%	0.0%	0.0%	0.0%	0.1%					
Buses	0	70	2	0	72	0	0	0	0	0	9	47	0	0	56	0	0	0	0	0	0	0	2	0	2	0	0	0	0	0	0	0	0	0	0	130					
% Buses	0.0%	3.9%	0.3%	0.0%	0.0%	0.0%	0.0%	0.0%	0.0%	0.0%	1.2%	4.4%	0.0%	0.0%	0.0%	0.0%	0.0%	0.0%	0.0%	0.0%	0.0%	0.0%	4.5%	0.0%	0.0%	0.0%	0.0%	0.0%	0.0%	0.0%	0.0%	0.0%	0.0%	0.0%	0.0%	3.0%					
Pedestrians	0	0	0	0	0	0	0	0	0	0	5	4	0	0	9	0	0	0	0	0	0	0	0	0	0	0	0	0	0	0	0	0	0	0	0	4					
% Pedestrians	0.0%	0.0%	0.0%	0.0%	0.0%	0.0%	0.0%	0.0%	0.0%	100.0%	80.0%	0.0%	0.0%	0.0%	0.0%	0.0%	0.0%	0.0%	0.0%	0.0%	0.0%	0.0%	0.0%	0.0%	0.0%	0.0%	0.0%	0.0%	0.0%	0.0%	0.0%	80.0%	85.7%	0.0%	0.0%	0.0%	0.0%				
Bicycles on Crosswalk	0	0	0	0	0	0	0	0	0	0	0	0	0	0	0	0	0	0	0	0	0	0	0	0	0	0	0	0	0	0	0	0	0	0	0	1					
% Bicycles on Crosswalk	0.0%	0.0%	0.0%	0.0%	0.0%	0.0%	0.0%	0.0%	0.0%	0.0%	0.0%	0.0%	0.0%	0.0%	0.0%	0.0%	0.0%	0.0%	0.0%	0.0%	0.0%	0.0%	0.0%	0.0%	0.0%	0.0%	0.0%	0.0%	0.0%	0.0%	20.0%	14.3%	0.0%	0.0%	0.0%	0.0%					

Project : VBH Malta NY
 Site : Site 4
 Location : 42.948550, -73.790036
 Survey Date : 2021-04-28, Wednesday

Turning Movement Data Plot

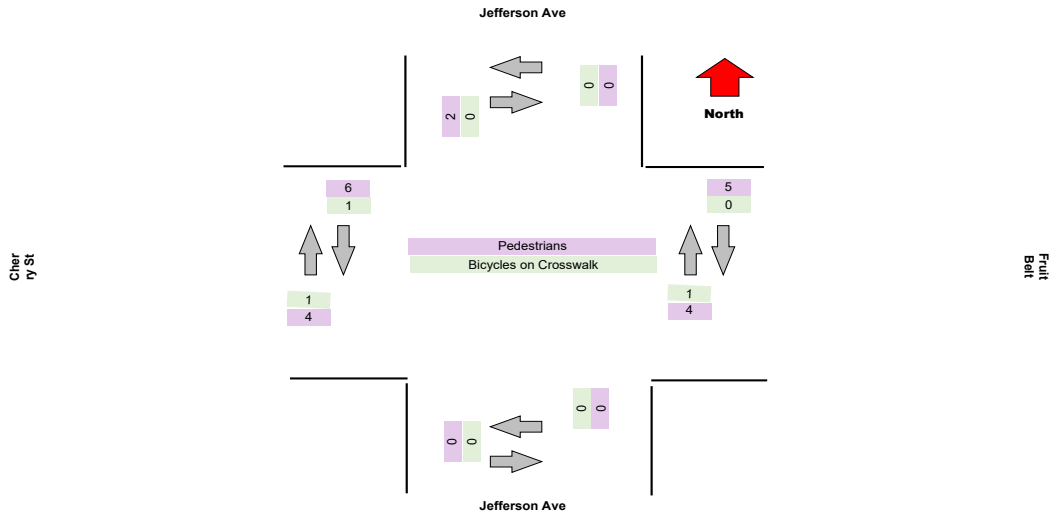
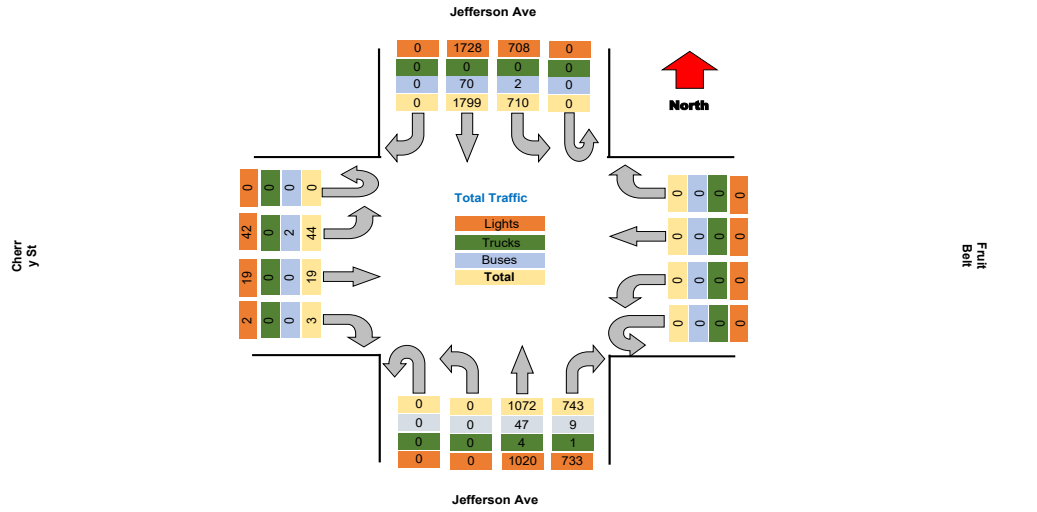

Turning Movement Peak Hour Data (AM)

7:30:00 AM

Leg Direction	Jefferson Ave						Fruit Belt						Jefferson Ave						Cherry St						Total					
	Southbound			Northbound			Westbound			Eastbound			Northbound			Eastbound														
Start Time	Right	Thru	Left	U-Turn	App Total	Peds CW	Peds CCW	Right	Thru	Left	U-Turn	App Total	Peds CW	Peds CCW	Right	Thru	Left	U-Turn	App Total	Peds CW	Peds CCW	Right	Thru	Left	U-Turn	App Total	Peds CW	Peds CCW		
7:30:00 AM	0	94	30	0	124	0	0	0	0	0	0	0	0	0	37	76	0	0	113	0	0	0	3	2	0	5	0	1	242	
7:45:00 AM	0	109	34	0	143	0	0	0	0	0	0	0	0	0	40	102	0	0	142	0	0	0	0	4	0	4	0	0	289	
8:00:00 AM	0	104	32	0	136	0	0	0	0	0	0	0	1	0	41	89	0	0	131	0	0	0	1	5	0	6	0	1	273	
8:15:00 AM	0	125	28	0	153	0	0	0	0	0	0	1	0	0	35	63	0	0	99	0	0	0	0	2	0	2	1	0	254	
Grand Total	0	432	124	0	556	0	0	0	0	0	0	2	0	0	153	330	0	0	485	0	0	0	4	13	0	17	1	2	1088	
% Approach	0.0%	77.7%	22.3%	0.0%	0.0%	0.0%	0.0%	#DIV/0!	#DIV/0!	#DIV/0!	#DIV/0!	0.0%	0.0%	0.0%	31.5%	68.0%	0.0%	0.0%	0.0%	0.0%	0.0%	0.0%	0.0%	23.5%	76.5%	0.0%	0.0%	0.0%	0.0%	
% Total	0.0%	40.8%	11.7%	0.0%	52.6%	0.0%	0.0%	0.0%	0.0%	0.0%	0.0%	0.0%	0.0%	0.0%	14.5%	31.2%	0.0%	0.0%	45.8%	0.0%	0.0%	0.0%	0.0%	0.4%	1.2%	0.0%	1.6%	0.0%	0.0%	
PHF	0.000	0.864	0.912	0.000	0.908	0.000	0.000	0.000	0.000	0.000	0.000	0.000	0.000	0.000	0.933	0.809	0.000	0.000	0.854	0.000	0.000	0.000	0.000	0.333	0.650	0.000	0.708	0.000	0.000	0.915
Lights	0	403	124	0	527	0	0	0	0	0	0	0	0	0	147	308	0	0	455	0	0	0	4	12	0	16	0	0	998	
% Lights	0.0%	93.3%	100.0%	0.0%	94.8%	0.0%	0.0%	0.0%	0.0%	0.0%	0.0%	0.0%	0.0%	0.0%	96.1%	93.3%	0.0%	0.0%	93.8%	0.0%	0.0%	0.0%	100.0%	92.3%	0.0%	94.1%	0.0%	0.0%	94.3%	
Trucks	0	0	0	0	0	0	0	0	0	0	0	0	0	0	1	2	0	0	3	0	0	0	0	0	0	0	0	0	3	
% Trucks	0.0%	0.0%	0.0%	0.0%	0.0%	0.0%	0.0%	0.0%	0.0%	0.0%	0.0%	0.0%	0.0%	0.0%	0.7%	0.6%	0.0%	0.0%	0.6%	0.0%	0.0%	0.0%	0.0%	0.0%	0.0%	0.0%	0.0%	0.0%	0.3%	
Buses	0	29	0	0	29	0	0	0	0	0	0	0	0	0	5	20	0	0	25	0	0	0	0	1	0	1	0	0	55	
% Buses	0.0%	6.7%	0.0%	0.0%	0.0%	0.0%	0.0%	0.0%	0.0%	0.0%	0.0%	0.0%	0.0%	0.0%	3.3%	6.1%	0.0%	0.0%	0.0%	0.0%	0.0%	0.0%	0.0%	7.7%	0.0%	0.0%	0.0%	0.0%	5.2%	
Pedestrians	0	0	0	0	0	0	0	0	0	0	2	0	0	0	0	0	0	0	0	0	0	0	0	0	0	0	1	2	0	
% Pedestrians	0.0%	0.0%	0.0%	0.0%	0.0%	0.0%	0.0%	0.0%	0.0%	0.0%	100.0%	0.0%	0.0%	0.0%	0.0%	0.0%	0.0%	0.0%	0.0%	0.0%	0.0%	0.0%	0.0%	0.0%	0.0%	0.0%	0.0%	100.0%	100.0%	0.0%
Bicycles on Crosswalk	0	0	0	0	0	0	0	0	0	0	0	0	0	0	0	0	0	0	0	0	0	0	0	0	0	0	0	0	0	
% Bicycles on Crosswalk	0.0%	0.0%	0.0%	0.0%	0.0%	0.0%	0.0%	0.0%	0.0%	0.0%	0.0%	0.0%	0.0%	0.0%	0.0%	0.0%	0.0%	0.0%	0.0%	0.0%	0.0%	0.0%	0.0%	0.0%	0.0%	0.0%	0.0%	0.0%	0.0%	

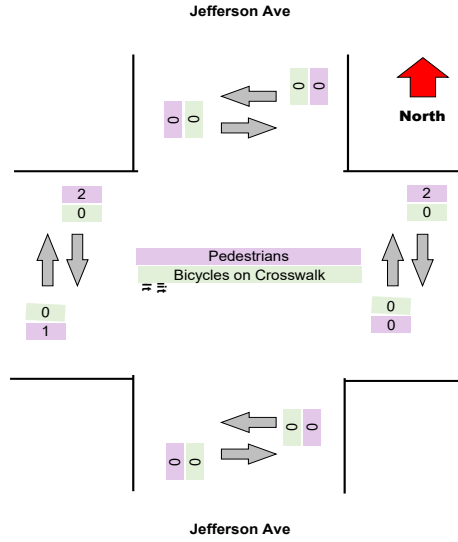
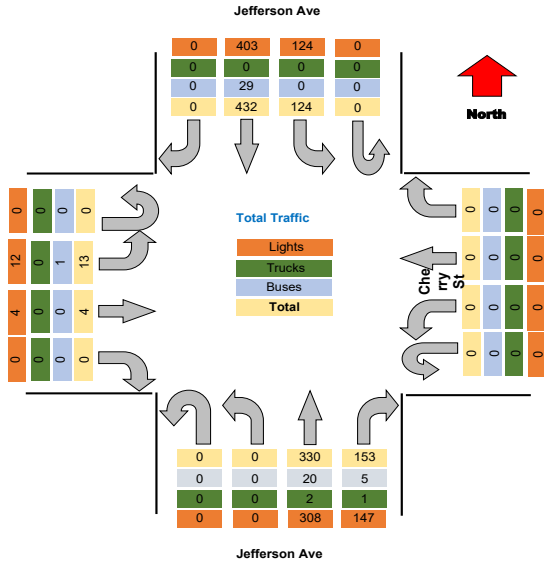

Turning Movement Peak Hour Data (PM)

4:15:00 PM

Leg Direction	Jefferson Ave								Fruit Belt								Jefferson Ave								Cherry St								Total
	Southbound				Northbound				Westbound				Eastbound				Northbound				Eastbound												
Start Time	Right	Thru	Left	U-Turn	App Total	Peds CW	Peds CCW		Right	Thru	Left	U-Turn	App Total	Peds CW	Peds CCW		Right	Thru	Left	U-Turn	App Total	Peds CW	Peds CCW		Right	Thru	Left	U-Turn	App Total	Peds CW	Peds CCW		
4:15:00 PM	0	169	72	0	241	2	0	0	0	0	0	0	0	0	0	2	62	80	0	0	142	0	0	0	0	1	3	0	4	0	0	0	387
4:30:00 PM	0	129	70	0	199	0	0	0	0	0	0	0	0	2	0	0	81	76	0	0	157	0	0	0	0	1	5	0	6	0	0	0	362
4:45:00 PM	0	146	65	0	211	0	0	0	0	0	0	0	0	0	0	0	65	68	0	0	133	0	0	0	0	2	2	0	4	2	3	0	348
5:00:00 PM	0	135	76	0	211	0	0	0	0	0	0	0	0	0	0	0	70	73	0	0	143	0	0	0	0	0	3	0	3	1	1	0	357
Grand Total	0	579	283	0	862	2	0	0	0	0	0	0	0	2	0	0	278	297	0	0	575	0	0	0	0	4	13	0	17	3	4	0	1454
% Approach	0.0%	67.2%	32.8%	0.0%	0.0%	0.0%	0.0%		0.0%	0.0%	0.0%	0.0%	0.0%	0.0%	0.0%		48.3%	51.7%	0.0%	0.0%	0.0%	0.0%	0.0%		0.0%	23.5%	76.5%	0.0%	0.0%	0.0%	0.0%		
% Total	0.0%	39.8%	19.5%	0.0%	59.3%	0.0%	0.0%		0.0%	0.0%	0.0%	0.0%	0.0%	0.0%	0.0%		19.1%	20.4%	0.0%	0.0%	39.5%	0.0%	0.0%		0.0%	0.3%	0.9%	0.0%	1.2%	0.0%	0.0%		
PHF	0.000	0.857	0.931	0.000	0.894	0.000	0.000		0.000	0.000	0.000	0.000	0.000	0.000	0.000		0.858	0.928	0.000	0.000	0.916	0.000	0.000		0.000	0.500	0.650	0.000	0.708	0.000	0.000		
Lights	0	562	283	0	845	0	0	0	0	0	0	0	0	0	0	0	278	285	0	0	561	0	0	0	0	4	13	0	17	0	0	0	1423
% Lights	0.0%	97.1%	100.0%	0.0%	98.0%	0.0%	0.0%		0.0%	0.0%	0.0%	0.0%	0.0%	0.0%	0.0%		99.3%	96.0%	0.0%	0.0%	97.6%	0.0%	0.0%		0.0%	100.0%	100.0%	0.0%	100.0%	0.0%	0.0%		
Trucks	0	0	0	0	0	0	0	0	0	0	0	0	0	0	0	0	0	1	0	0	1	0	0	0	0	0	0	0	0	0	0	0	1
% Trucks	0.0%	0.0%	0.0%	0.0%	0.0%	0.0%	0.0%		0.0%	0.0%	0.0%	0.0%	0.0%	0.0%	0.0%		0.0%	0.3%	0.0%	0.0%	0.2%	0.0%	0.0%		0.0%	0.0%	0.0%	0.0%	0.0%	0.0%	0.0%		
Buses	0	17	0	0	17	0	0	0	0	0	0	0	0	0	0	0	2	10	0	0	12	0	0	0	0	0	0	0	0	0	0	0	29
% Buses	0.0%	2.9%	0.0%	0.0%	0.0%	0.0%	0.0%		0.0%	0.0%	0.0%	0.0%	0.0%	0.0%	0.0%		0.7%	3.4%	0.0%	0.0%	0.0%	0.0%	0.0%		0.0%	0.0%	0.0%	0.0%	0.0%	0.0%	0.0%		
Pedestrians	0	0	0	0	0	2	0	0	0	0	0	0	0	2	3	0	0	0	0	0	0	0	0	0	0	0	0	0	0	3	4	0	
% Pedestrians	0.0%	0.0%	0.0%	0.0%	0.0%	100.0%	0.0%		0.0%	0.0%	0.0%	0.0%	0.0%	100.0%	100.0%		0.0%	0.0%	0.0%	0.0%	0.0%	0.0%	0.0%		0.0%	0.0%	0.0%	0.0%	0.0%	100.0%	100.0%		
Bicycles on Crosswalk	0	0	0	0	0	0	0	0	0	0	0	0	0	0	0	0	0	0	0	0	0	0	0	0	0	0	0	0	0	0	0	0	0
% Bicycles on Crosswalk	0.0%	0.0%	0.0%	0.0%	0.0%	0.0%	0.0%		0.0%	0.0%	0.0%	0.0%	0.0%	0.0%	0.0%		0.0%	0.0%	0.0%	0.0%	0.0%	0.0%	0.0%		0.0%	0.0%	0.0%	0.0%	0.0%	0.0%	0.0%		

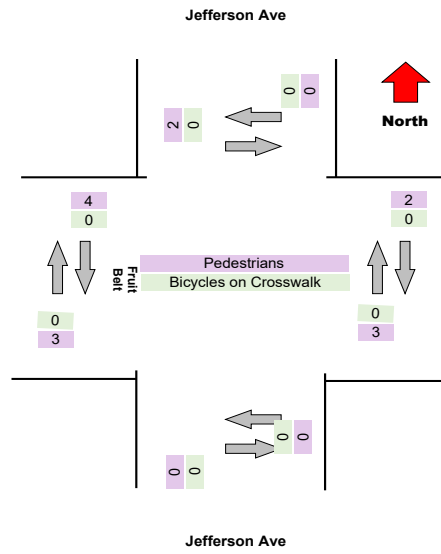
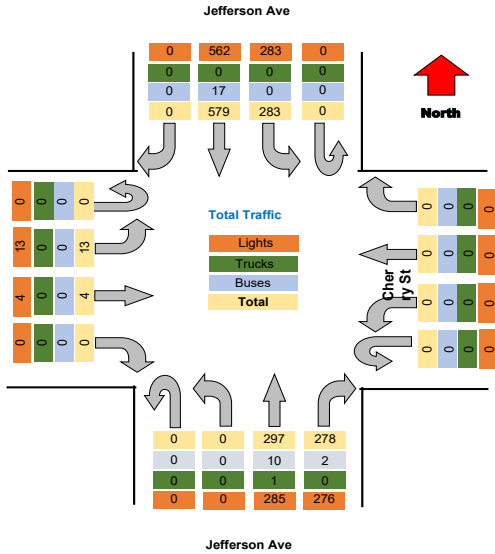

Project : VBH Malta NY
 Site : Site 4
 Location : 42.948550, -73.790036

TSTData.com

Survey Date : 2021-04-28, Wednesday

Project	LaBella
Project Code	LaBella
Site Name	11
Legs and Movements	All Processed Legs & Move
Bin Size	15 minutes
Survey Date	2021-11-02, Tuesday
Location	11
Latitude and Longitude	42.897816, -78.853982

	Start	End	PHF
Forced Peak AM	2021/11/02 07:30:00	2021/11/02 08:30:00	0.94
Forced Peak PM	2021/11/02 16:30:00	2021/11/02 17:30:00	0.96
AM Peak	2021/11/02 07:30:00	2021/11/02 08:30:00	0.94
PM Peak	2021/11/02 16:15:00	2021/11/02 17:15:00	0.96

Turning Movement Data

Leg Direction	Jefferson Ave										Fruit Belt										Jefferson Ave										B F N C Dr										Total
	Southbound					Westbound					Northbound					Eastbound					Eastbound					Eastbound															
	Right	Thru	Left	U-Turn	App Total	Right	Thru	Left	U-Turn	App Total	Right	Thru	Left	U-Turn	App Total	Right	Thru	Left	U-Turn	App Total	Right	Thru	Left	U-Turn	App Total	Right	Thru	Left	U-Turn	App Total											
6:30:00 AM	0	35	0	0	35	0	0	1	36	0	21	0	0	21	0	30	4	0	34	0	0	0	0	0	0	0	0	0	0	0	0	0	0	0	128						
6:45:00 AM	4	32	0	0	36	7	1	19	0	27	0	0	0	0	0	0	33	9	0	42	0	0	0	0	0	0	0	0	0	0	0	0	0	0	0	170					
Hourly Total	4	67	0	0	71	7	1	19	0	27	0	0	0	0	0	0	63	13	0	76	0	0	0	0	0	0	0	0	0	0	0	0	0	0	0	238					
7:00:00 AM	1	60	0	0	61	0	0	24	0	24	0	0	0	0	0	0	31	3	0	34	0	0	0	0	0	0	0	0	0	0	0	0	0	0	0	160					
7:15:00 AM	3	34	0	0	37	0	0	38	0	38	0	0	0	0	0	0	30	5	0	35	0	0	0	0	0	0	0	0	0	0	0	0	0	0	0	170					
7:30:00 AM	2	47	0	0	49	0	0	33	0	33	0	0	0	0	0	0	48	9	0	57	0	0	0	0	0	0	0	0	0	0	0	0	0	0	0	210					
7:45:00 AM	3	45	0	0	48	0	0	43	0	43	0	0	0	0	0	0	43	5	0	48	0	0	0	0	0	0	0	0	0	0	0	0	0	0	0	214					
Hourly Total	9	186	0	0	195	0	0	138	0	138	0	0	0	0	0	0	152	22	0	174	0	0	0	0	0	0	0	0	0	0	0	0	0	0	0	754					
8:00:00 AM	2	65	0	0	67	0	0	39	0	39	0	0	0	0	0	0	49	8	0	57	0	0	0	0	0	0	0	0	0	0	0	0	0	0	0	230					
8:15:00 AM	3	61	0	0	64	0	0	38	0	38	0	0	0	0	0	0	37	9	0	46	0	0	0	0	0	0	0	0	0	0	0	0	0	0	0	209					
Hourly Total	5	126	0	0	131	0	0	77	0	77	0	0	0	0	0	0	86	17	0	103	0	0	0	0	0	0	0	0	0	0	0	0	0	0	0	439					
4:00:00 PM	3	148	0	0	151	0	0	52	0	52	0	0	0	0	0	0	63	7	0	70	0	0	0	0	0	0	0	0	0	0	0	0	0	0	0	299					
4:15:00 PM	5	146	0	0	151	0	0	62	0	62	0	0	0	0	0	0	48	5	0	53	0	0	0	0	0	0	0	0	0	0	0	0	0	0	0	301					
4:30:00 PM	7	171	0	0	178	0	0	53	0	53	0	0	0	0	0	0	48	5	0	53	0	0	0	0	0	0	0	0	0	0	0	0	0	0	0	314					
4:45:00 PM	4	153	0	0	157	0	0	62	0	62	0	0	0	0	0	0	67	11	0	78	0	0	0	0	0	0	0	0	0	0	0	0	0	0	0	322					
Hourly Total	19	618	0	0	637	0	0	229	0	229	0	0	0	0	0	0	226	28	0	254	0	0	0	0	0	0	0	0	0	0	0	0	0	0	0	1236					
5:00:00 PM	4	147	0	0	151	0	0	43	0	43	0	0	0	0	0	0	77	3	0	80	0	0	0	0	0	0	0	0	0	0	0	0	0	0	0	295					
5:15:00 PM	8	160	0	0	168	0	0	51	0	51	0	0	0	0	0	0	66	7	0	73	0	0	0	0	0	0	0	0	0	0	0	0	0	0	0	310					
5:30:00 PM	11	117	0	0	128	0	0	66	0	66	0	0	0	0	0	0	55	16	0	71	0	0	0	0	0	0	0	0	0	0	0	0	0	0	0	284					
5:45:00 PM	6	109	0	0	115	0	0	57	0	57	0	0	0	0	0	0	57	10	0	67	0	0	0	0	0	0	0	0	0	0	0	0	0	0	0	259					
Hourly Total	29	533	0	0	562	0	0	217	0	217	0	0	0	0	0	0	255	36	0	291	0	0	0	0	0	0	0	0	0	0	0	0	0	0	0	1148					
Grand Total	66	1530	0	0	1596	0	0	701	0	701	0	0	0	0	0	0	782	116	0	898	0	0	0	0	0	0	0	0	0	0	0	0	0	0	0	3875					
% Approach	4.1%	95.9%	0.0%	0.0%	0.0%	0.0%	0.0%	50.9%	0.0%	0.0%	0.0%	0.0%	0.0%	0.0%	0.0%	0.0%	86.6%	12.8%	0.0%	0.0%	0.0%	0.0%	0.0%	0.0%	0.0%	0.0%	0.0%	0.0%	0.0%	0.0%	0.0%	0.0%	0.0%	0.0%	0.0%						
% Total	1.7%	39.5%	0.0%	0.0%	41.2%	0.0%	0.0%	18.1%	0.0%	35.5%	0.0%	0.0%	0.0%	0.0%	0.0%	0.0%	20.2%	3.0%	0.0%	23.3%	0.0%	0.0%	0.0%	0.0%	0.0%	0.0%	0.0%	0.0%	0.0%	0.0%	0.0%	0.0%	0.0%	0.0%	0.0%						
Lights	66	1512	0	0	1578	0	0	695	0	1365	0	0	0	0	0	0	766	114	0	880	0	0	0	0	0	0	0	0	0	0	0	0	0	0	0	3823					
% Lights	100.0%	98.8%	0.0%	0.0%	98.8%	0.0%	0.0%	99.9%	0.0%	99.2%	0.0%	0.0%	0.0%	0.0%	0.0%	0.0%	88.0%	98.3%	0.0%	97.8%	0.0%	0.0%	0.0%	0.0%	0.0%	0.0%	0.0%	0.0%	0.0%	0.0%	0.0%	0.0%	0.0%	0.0%	0.0%						
Trucks	0	2	0	0	2	0	0	3	0	3	0	0	0	0	0	0	0	0	0	0	0	0	0	0	0	0	0	0	0	0	0	0	0	0	0	5					
% Trucks	0.0%	0.1%	0.0%	0.0%	0.1%	0.0%	0.0%	0.4%	0.0%	0.2%	0.0%	0.0%	0.0%	0.0%	0.0%	0.0%	0.0%	0.0%	0.0%	0.0%	0.0%	0.0%	0.0%	0.0%	0.0%	0.0%	0.0%	0.0%	0.0%	0.0%	0.0%	0.0%	0.0%	0.0%	0.1%						
Buses	0	14	0	0	14	0	0	3	0	3	0	0	0	0	0	0	16	2	0	18	0	0	0	0	0	0	0	0	0	0	0	0	0	0	0	38					
% Buses	0.0%	0.9%	0.0%	0.0%	0.9%	0.0%	0.0%	0.4%	0.0%	0.2%	0.0%	0.0%	0.0%	0.0%	0.0%	0.0%	2.0%	1.7%	0.0%	0.0%	0.0%	0.0%	0.0%	0.0%	0.0%	0.0%	0.0%	0.0%	0.0%	0.0%	0.0%	0.0%	0.0%	0.0%	1.0%						
Pedestrians	0	0	0	0	0	0	0	0	0	0	5	7	0	0	0	0	0	0	0	0	1	0	0	0	0	0	0	0	0	0	0	0	0	0	0	12					
% Pedestrians	0.0%	0.0%	0.0%	0.0%	0.0%	0.0%	0.0%	0.0%	0.0%	0.0%	100.0%	77.8%	0.0%	0.0%	0.0%	0.0%	0.0%	0.0%	0.0%	0.0%	100.0%	0.0%	0.0%	0.0%	0.0%	0.0%	0.0%	0.0%	0.0%	0.0%	66.7%	75.0%	0.0%	0.0%	0.0%						
Bicycles on Crosswalk	0	0	0	0	0	0	0	0	0	0	0	2	0	0	0	0	0	0	0	0	0	0	0	0	0	0	0	0	0	0	0	0	0	0	0	2					
% Bicycles on Crosswalk	0.0%	0.0%	0.0%	0.0%	0.0%	0.0%	0.0%	0.0%	0.0%	0.0%	0.0%	22.2%	0.0%	0.0%	0.0%	0.0%	0.0%	0.0%	0.0%	0.0%	0.0%	0.0%	0.0%	0.0%	0.0%	0.0%	0.0%	0.0%	0.0%	0.0%	0.0%	0.0%	0.0%	0.0%	0.0%						

Turning Movement Data Plot

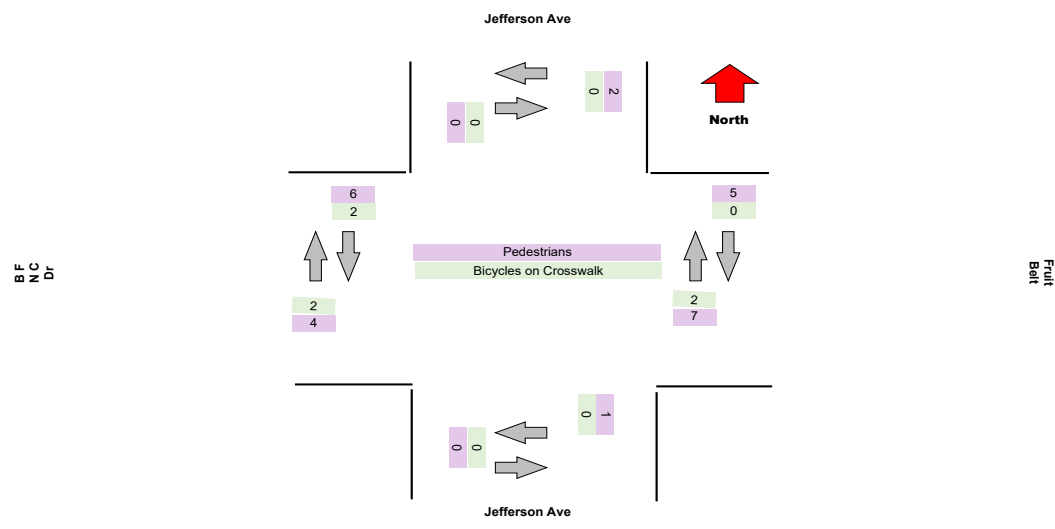
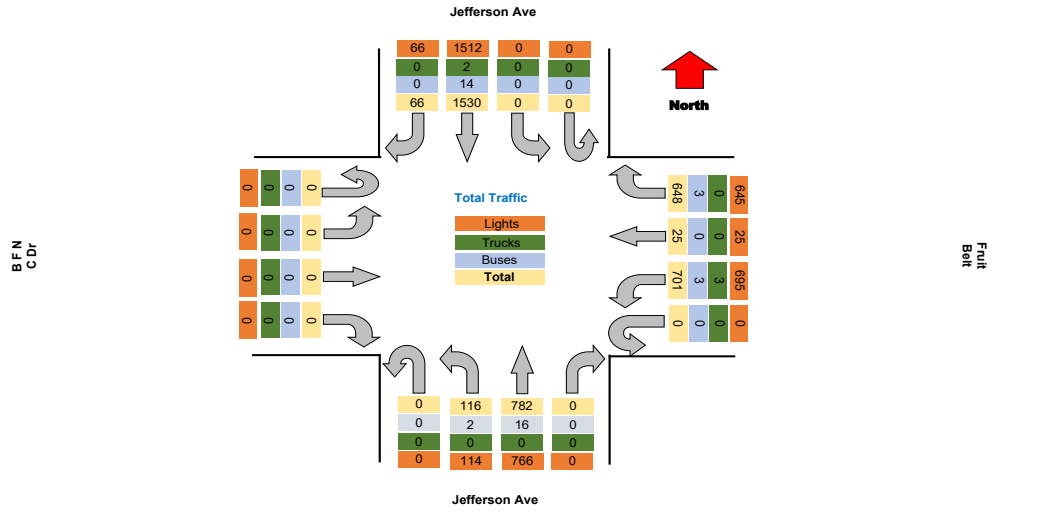

Project : VBH Malta NY
Site : Site 4
Location : 42.948550, -73.790036

TSTData.com

Survey Date : 2021-04-28, Wednesday

Turning Movement Peak Hour Data (AM)

7:30:00 AM

Leg Direction	Jefferson Ave						Fruit Belt						Jefferson Ave						B F N C Dr						Total					
	Southbound			Westbound			Northbound			Eastbound			Northbound			Eastbound														
Start Time	Right	Thru	Left	U-Turn	App Total	Peds CW	Peds CCW	Right	Thru	Left	U-Turn	App Total	Peds CW	Peds CCW	Right	Thru	Left	U-Turn	App Total	Peds CW	Peds CCW	Right	Thru	Left	U-Turn	App Total	Peds CW	Peds CCW		
7:30:00 AM	2	47	0	0	49	0	0	71	0	33	0	104	0	0	0	48	9	0	57	0	0	0	0	0	0	0	0	0	1	210
7:45:00 AM	3	45	0	0	48	0	0	74	1	43	0	118	0	0	0	43	5	0	48	0	0	0	0	0	0	0	0	1	0	214
8:00:00 AM	2	65	0	0	67	0	0	67	0	39	0	106	0	0	0	49	8	0	57	0	0	0	0	0	0	0	0	1	0	230
8:15:00 AM	3	61	0	0	64	0	0	56	2	38	0	97	0	0	0	37	9	0	46	0	0	0	0	0	0	0	0	1	0	209
Grand Total	10	218	0	0	228	0	0	268	3	152	0	423	0	0	0	177	31	0	210	0	0	0	0	0	0	0	2	2	863	
% Approach	4.4%	95.6%	0.0%	0.0%	0.0%	0.0%	0.0%	63.1%	0.7%	36.0%	0.0%	0.0%	0.0%	0.0%	0.0%	84.3%	14.8%	0.0%	0.0%	0.0%	0.0%	#DIV/0!	#DIV/0!	#DIV/0!	###	0.0%	0.0%	0.0%		
% Total	1.2%	25.3%	0.0%	0.0%	26.4%	0.0%	0.0%	31.1%	0.3%	17.7%	0.0%	49.2%	0.0%	0.0%	0.0%	20.5%	3.6%	0.0%	24.3%	0.0%	0.0%	0.0%	0.0%	0.0%	0.0%	0.0%	0.0%	0.0%	0.0%	
PHF	0.833	0.838	0.000	0.000	0.851	0.000	0.000	0.905	0.375	0.890	0.000	0.900	0.000	0.000	0.000	0.903	0.861	0.000	0.821	0.000	0.000	0.000	0.000	0.000	0.000	0.000	0.000	0.000	0.938	
Lights	10	213	0	0	223	0	0	268	3	152	0	423	0	0	0	175	30	0	205	0	0	0	0	0	0	0	0	0	851	
% Lights	100.0%	97.7%	0.0%	0.0%	97.8%	0.0%	0.0%	100.0%	100.0%	99.3%	0.0%	99.5%	0.0%	0.0%	0.0%	98.0%	96.8%	0.0%	97.6%	0.0%	0.0%	0.0%	0.0%	0.0%	0.0%	0.0%	0.0%	0.0%	98.6%	
Trucks	0	0	0	0	0	0	0	0	0	0	0	0	0	0	0	0	0	0	0	0	0	0	0	0	0	0	0	0	0	
% Trucks	0.0%	0.0%	0.0%	0.0%	0.0%	0.0%	0.0%	0.0%	0.0%	0.0%	0.0%	0.0%	0.0%	0.0%	0.0%	0.0%	0.0%	0.0%	0.0%	0.0%	0.0%	0.0%	0.0%	0.0%	0.0%	0.0%	0.0%	0.0%	0.0%	
Buses	0	5	0	0	5	0	0	0	0	1	0	1	0	0	0	2	1	0	3	0	0	0	0	0	0	0	0	0	9	
% Buses	0.0%	2.3%	0.0%	0.0%	0.0%	0.0%	0.0%	0.0%	0.0%	0.7%	0.0%	0.0%	0.0%	0.0%	0.0%	1.1%	3.2%	0.0%	0.0%	0.0%	0.0%	0.0%	0.0%	0.0%	0.0%	0.0%	0.0%	0.0%	1.0%	
Pedestrians	0	0	0	0	0	0	0	0	0	0	0	0	1	1	0	0	0	0	0	0	0	0	0	0	0	0	0	1	2	
% Pedestrians	0.0%	0.0%	0.0%	0.0%	0.0%	0.0%	100.0%	0.0%	0.0%	0.0%	0.0%	0.0%	100.0%	100.0%	0.0%	0.0%	0.0%	0.0%	0.0%	0.0%	0.0%	0.0%	0.0%	0.0%	0.0%	0.0%	0.0%	50.0%	100.0%	
Bicycles on Crosswalk	0	0	0	0	0	0	0	0	0	0	0	0	0	0	0	0	0	0	0	0	0	0	0	0	0	0	0	1	0	
% Bicycles on Crosswalk	0.0%	0.0%	0.0%	0.0%	0.0%	0.0%	0.0%	0.0%	0.0%	0.0%	0.0%	0.0%	0.0%	0.0%	0.0%	0.0%	0.0%	0.0%	0.0%	0.0%	0.0%	0.0%	0.0%	0.0%	0.0%	0.0%	0.0%	50.0%	0.0%	

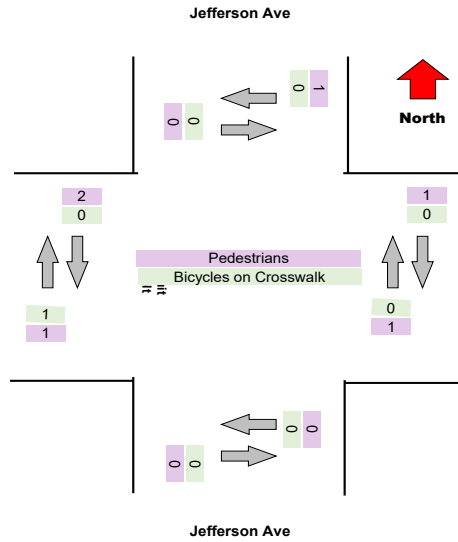
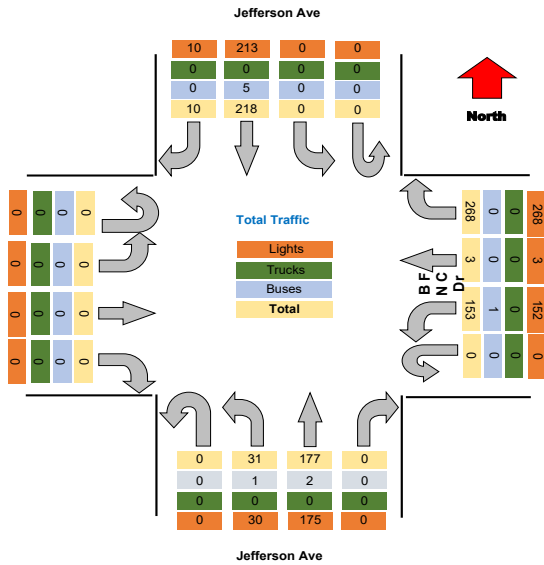

Turning Movement Peak Hour Data (PM)

4:15:00 PM

Leg Direction	Jefferson Ave						Fruit Belt						Jefferson Ave						B F N C Dr						Total					
	Southbound			Northbound			Westbound			Eastbound			Northbound			Eastbound														
Start Time	Right	Thru	Left	U-Turn	App Total	Peds CW	Peds CCW	Right	Thru	Left	U-Turn	App Total	Peds CW	Peds CCW	Right	Thru	Left	U-Turn	App Total	Peds CW	Peds CCW	Right	Thru	Left	U-Turn	App Total	Peds CW	Peds CCW		
4:15:00 PM	5	146	0	0	151	0	0	33	2	62	0	97	1	0	0	48	5	0	53	0	0	0	0	0	0	0	0	0	1	301
4:30:00 PM	7	171	0	0	178	0	0	25	5	53	0	83	0	2	0	48	5	0	53	1	0	0	0	0	0	0	0	0	1	314
4:45:00 PM	4	153	0	0	157	0	0	24	1	62	0	87	0	0	0	67	11	0	78	0	0	0	0	0	0	0	2	1	322	
5:00:00 PM	4	147	0	0	151	0	0	20	1	43	0	64	0	0	0	77	3	0	80	0	0	0	0	0	0	0	1	0	295	
Grand Total	20	617	0	0	637	0	0	102	9	220	0	331	1	0	0	240	24	0	264	1	0	0	0	0	0	0	3	2	1232	
% Approach	3.1%	96.9%	0.0%	0.0%	0.0%	0.0%	0.0%	30.8%	2.7%	66.5%	0.0%	0.0%	0.0%	0.0%	0.0%	90.9%	9.1%	0.0%	0.0%	0.0%	0.0%	#DIV/0!	#DIV/0!	#DIV/0!	###	0.0%	0.0%	0.0%		
% Total	1.6%	50.1%	0.0%	0.0%	51.7%	0.0%	0.0%	8.3%	0.7%	17.9%	0.0%	26.9%	0.0%	0.0%	0.0%	19.5%	1.9%	0.0%	21.4%	0.0%	0.0%	0.0%	0.0%	0.0%	0.0%	0.0%	0.0%	0.0%		
PHF	0.714	0.902	0.000	0.000	0.895	0.000	0.000	0.773	0.450	0.887	0.000	0.853	0.000	0.000	0.000	0.779	0.545	0.000	0.825	0.000	0.000	0.000	0.000	0.000	0.000	0.000	0.000	0.000	0.957	
Lights	20	610	0	0	630	0	0	101	9	220	0	330	0	0	0	235	24	0	259	0	0	0	0	0	0	0	0	0	1219	
% Lights	100.0%	98.9%	0.0%	0.0%	98.9%	0.0%	0.0%	99.0%	100.0%	100.0%	0.0%	99.7%	0.0%	0.0%	0.0%	97.9%	100.0%	0.0%	98.1%	0.0%	0.0%	0.0%	0.0%	0.0%	0.0%	0.0%	0.0%	0.0%	98.9%	
Trucks	0	1	0	0	1	0	0	0	0	0	0	0	0	0	0	0	0	0	0	0	0	0	0	0	0	0	0	0	1	
% Trucks	0.0%	0.2%	0.0%	0.0%	0.2%	0.0%	0.0%	0.0%	0.0%	0.0%	0.0%	0.0%	0.0%	0.0%	0.0%	0.0%	0.0%	0.0%	0.0%	0.0%	0.0%	0.0%	0.0%	0.0%	0.0%	0.0%	0.0%	0.0%	0.1%	
Buses	0	4	0	0	4	0	0	1	0	0	0	1	0	0	0	5	0	0	5	0	0	0	0	0	0	0	0	0	10	
% Buses	0.0%	0.6%	0.0%	0.0%	0.6%	0.0%	0.0%	1.0%	0.0%	0.0%	0.0%	0.3%	0.0%	0.0%	0.0%	2.1%	0.0%	0.0%	0.0%	0.0%	0.0%	0.0%	0.0%	0.0%	0.0%	0.0%	0.0%	0.0%	0.8%	
Pedestrians	0	0	0	0	0	0	0	0	0	0	0	1	3	0	0	0	0	0	0	1	0	0	0	0	0	0	0	2	1	
% Pedestrians	0.0%	0.0%	0.0%	0.0%	0.0%	0.0%	0.0%	0.0%	0.0%	0.0%	0.0%	0.3%	100.0%	100.0%	0.0%	0.0%	0.0%	0.0%	0.0%	0.0%	0.0%	0.0%	0.0%	0.0%	0.0%	0.0%	0.0%	50.7%	50.0%	
Bicycles on Crosswalk	0	0	0	0	0	0	0	0	0	0	0	0	0	0	0	0	0	0	0	0	0	0	0	0	0	0	1	1	0	
% Bicycles on Crosswalk	0.0%	0.0%	0.0%	0.0%	0.0%	0.0%	0.0%	0.0%	0.0%	0.0%	0.0%	0.0%	0.0%	0.0%	0.0%	0.0%	0.0%	0.0%	0.0%	0.0%	0.0%	0.0%	0.0%	0.0%	0.0%	0.0%	33.3%	50.0%	0.0%	

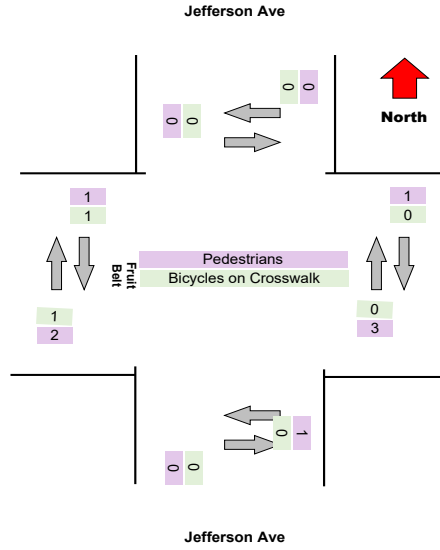
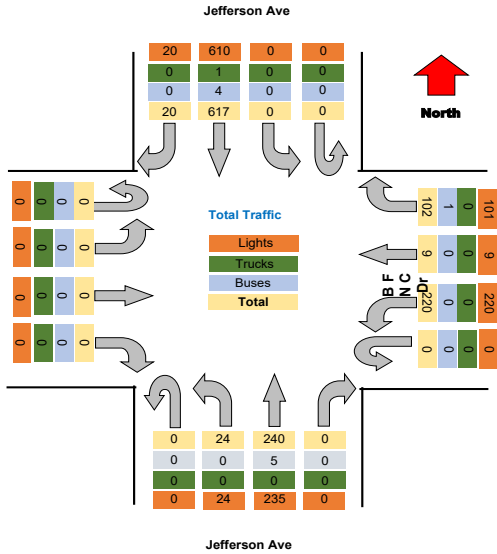

Project : VBH Malta NY
 Site : Site 4
 Location : 42.948550, -73.790036

TSTData.com

Survey Date : 2021-04-28, Wednesday

Project	LaBella
Project Code	LaBella
Site Name	11
Legs and Movements	All Processed Legs & Move
Bin Size	15 minutes
Survey Date	2021-11-03, Wednesday
Location	11
Latitude and Longitude	42.897816, -78.853982

	Start	End	PHF
Forced Peak AM	2021/11/03 07:30:00	2021/11/03 08:30:00	0.87
Forced Peak PM	2021/11/03 16:30:00	2021/11/03 17:30:00	0.92
AM Peak	2021/11/03 07:30:00	2021/11/03 08:30:00	0.87
PM Peak	2021/11/03 16:15:00	2021/11/03 17:15:00	0.93

Turning Movement Data

Leg Direction	Jefferson Ave							Fruit Belt							Jefferson Ave							B F N C Dr							Total	
	Southbound			Westbound				Northbound			Eastbound				Right			Left												
Start Time	Right	Thru	Left	U-Turn	App Total	Peds CW	Peds CCW	Right	Thru	Left	U-Turn	App Total	Peds CW	Peds CCW	Right	Thru	Left	U-Turn	App Total	Peds CW	Peds CCW	Right	Thru	Left	U-Turn	App Total	Peds CW	Peds CCW		
6:30:00 AM	1	31	0	0	32	0	0	45	0	22	0	67	0	0	0	36	4	0	40	0	0	0	0	0	0	0	0	0	1	139
6:45:00 AM	3	49	0	0	52	0	0	70	0	30	0	100	0	0	0	44	6	0	50	0	0	0	0	0	0	0	0	0	1	202
Hourly Total	4	80	0	0	84	0	0	115	0	52	0	167	0	0	0	88	10	0	98	0	0	0	0	0	0	0	0	0	2	341
7:00:00 AM	1	60	0	0	61	0	0	45	1	25	0	71	0	0	0	47	6	0	53	0	0	0	0	0	0	0	0	0	1	185
7:15:00 AM	2	56	0	0	58	0	0	79	4	44	0	127	0	0	0	54	6	0	60	0	0	0	0	0	0	0	0	1	245	
7:30:00 AM	5	67	0	0	72	0	0	86	3	51	0	140	0	0	0	60	7	0	67	0	0	1	0	0	0	0	1	2	280	
7:45:00 AM	3	90	0	0	93	0	0	104	10	55	0	169	0	0	0	90	16	0	106	1	0	0	0	0	0	0	0	1	0	368
Hourly Total	11	273	0	0	284	0	0	314	18	175	0	507	0	0	0	251	35	0	286	1	0	1	0	0	0	0	1	2	5	1078
8:00:00 AM	6	115	0	0	121	0	0	90	6	59	0	155	0	0	0	69	7	0	76	0	0	0	0	0	0	0	0	0	0	362
8:15:00 AM	4	83	0	0	87	0	0	70	1	61	0	132	0	0	0	52	6	0	58	0	0	0	0	0	0	0	0	0	0	277
Hourly Total	10	198	0	0	208	0	0	160	7	120	0	287	0	0	0	121	13	0	134	0	0	0	0	0	0	0	0	0	0	629
4:00:00 PM	9	168	0	0	177	0	0	29	3	59	0	91	0	0	0	80	3	0	83	0	0	0	0	0	0	0	0	2	4	351
4:15:00 PM	6	184	0	0	190	0	0	23	4	60	0	87	0	0	0	72	10	0	82	0	0	0	0	0	0	0	0	2	1	359
4:30:00 PM	4	192	0	0	196	0	0	27	3	45	0	75	0	0	0	72	11	0	83	0	0	0	0	0	0	0	0	1	0	354
4:45:00 PM	3	156	0	0	159	0	0	16	2	64	0	82	0	0	0	67	8	0	75	0	0	0	0	0	0	0	0	0	0	306
Hourly Total	22	690	0	0	712	0	0	95	12	228	0	335	0	0	0	291	32	0	323	0	0	0	0	0	0	0	0	5	5	1370
5:00:00 PM	4	164	0	0	168	0	0	22	2	40	0	64	0	1	0	76	10	0	86	0	0	0	0	0	0	0	0	0	0	318
5:15:00 PM	2	155	0	0	157	0	0	20	1	69	0	90	1	0	0	72	4	0	76	0	0	0	0	0	0	0	0	3	1	323
5:30:00 PM	8	108	0	0	116	0	0	17	4	58	0	79	1	0	0	66	9	0	75	0	0	0	0	0	0	0	0	1	1	270
5:45:00 PM	4	122	0	0	126	0	0	24	3	44	0	71	1	0	0	52	1	0	53	0	0	0	0	0	0	0	0	0	0	280
Hourly Total	18	549	0	0	567	0	0	83	10	211	0	304	3	1	0	266	24	0	290	0	0	0	0	0	0	0	0	4	2	1161
Grand Total	65	1790	0	0	1855	0	0	767	47	786	0	1600	3	1	0	1009	114	0	1123	1	0	1	0	0	0	0	1	13	14	4579
% Approach	3.5%	96.5%	0.0%	0.0%	0.0%	0.0%	0.0%	47.9%	2.9%	49.1%	0.0%	0.0%	0.0%	0.0%	0.0%	89.8%	10.2%	0.0%	0.0%	0.0%	0.0%	0.0%	0.0%	0.0%	0.0%	0.0%	0.0%	0.0%	0.0%	0.0%
% Total	1.4%	39.1%	0.0%	0.0%	40.5%	0.0%	0.0%	16.8%	1.0%	17.2%	0.0%	34.9%	0.0%	0.0%	0.0%	22.0%	2.5%	0.0%	24.5%	0.0%	0.0%	0.0%	0.0%	0.0%	0.0%	0.0%	0.0%	0.0%	0.0%	0.0%
Lights	62	1728	0	0	1790	0	0	763	45	773	0	1581	0	0	0	964	105	0	1069	0	0	0	0	0	0	0	0	0	0	4441
% Lights	95.4%	96.5%	0.0%	0.0%	96.5%	0.0%	0.0%	99.5%	95.7%	98.3%	0.0%	99.8%	0.0%	0.0%	0.0%	95.5%	92.1%	0.0%	95.2%	0.0%	0.0%	0.0%	0.0%	0.0%	0.0%	0.0%	0.0%	0.0%	0.0%	97.0%
Trucks	0	1	0	0	1	0	0	1	0	2	0	3	0	0	0	0	1	0	1	0	0	0	0	0	0	0	0	0	0	5
% Trucks	0.0%	0.1%	0.0%	0.0%	0.1%	0.0%	0.0%	0.1%	0.0%	0.3%	0.0%	0.2%	0.0%	0.0%	0.0%	0.0%	0.9%	0.0%	0.1%	0.0%	0.0%	0.0%	0.0%	0.0%	0.0%	0.0%	0.0%	0.0%	0.1%	
Buses	3	61	0	0	64	0	0	3	2	11	0	16	0	0	0	45	8	0	53	0	0	0	0	0	0	0	0	0	0	133
% Buses	4.6%	3.4%	0.0%	0.0%	0.0%	0.0%	0.0%	0.0%	4.3%	1.4%	0.0%	0.0%	0.0%	0.0%	0.0%	4.5%	7.0%	0.0%	0.0%	0.0%	0.0%	0.0%	0.0%	0.0%	0.0%	0.0%	0.0%	0.0%	0.0%	2.3%
Pedestrians	0	0	0	0	0	0	0	0	0	0	0	0	2	1	0	0	0	0	0	1	0	0	0	0	0	0	0	7	12	0
% Pedestrians	0.0%	0.0%	0.0%	0.0%	0.0%	0.0%	0.0%	0.0%	0.0%	0.0%	0.0%	0.0%	66.7%	100.0%	0.0%	0.0%	0.0%	0.0%	0.0%	100.0%	0.0%	0.0%	0.0%	0.0%	0.0%	0.0%	0.0%	63.8%	85.7%	0.0%
Bicycles on Crosswalk	0	0	0	0	0	0	0	0	0	0	0	0	1	0	0	0	0	0	0	0	0	0	0	0	0	0	0	4	2	0
% Bicycles on Crosswalk	0.0%	0.0%	0.0%	0.0%	0.0%	0.0%	0.0%	0.0%	0.0%	0.0%	0.0%	0.0%	33.3%	0.0%	0.0%	0.0%	0.0%	0.0%	0.0%	0.0%	0.0%	0.0%	0.0%	0.0%	0.0%	0.0%	0.0%	36.4%	14.3%	0.0%

Project : VBH Malta NY
 Site : Site 4
 Location : 42.948550, -73.790036
 Survey Date : 2021-04-28, Wednesday

Turning Movement Data Plot

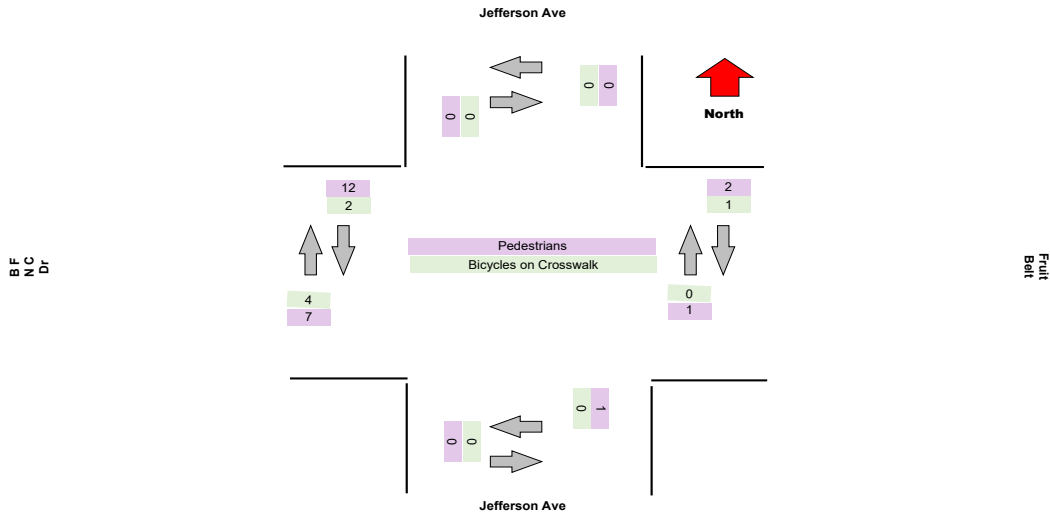
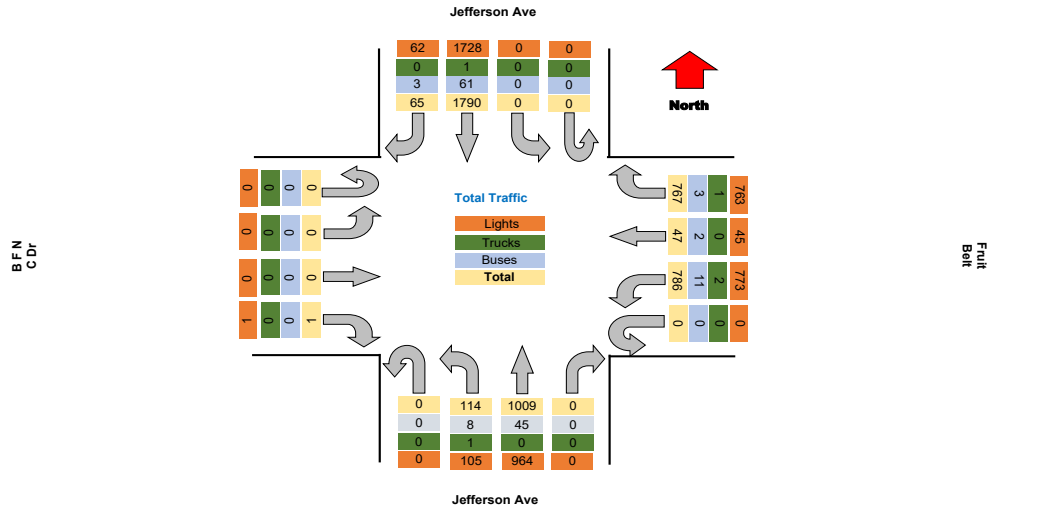

Turning Movement Peak Hour Data (AM)

7:30:00 AM

Leg Direction	Jefferson Ave					Fruit Belt					Jefferson Ave					B F N C Dr					Total		
	Right	Thru	Left	U-Turn	App Total	Right	Thru	Left	U-Turn	App Total	Right	Thru	Left	U-Turn	App Total	Right	Thru	Left	U-Turn	App Total			
7:30:00 AM	5	67	0	0	72	86	3	51	0	140	0	60	7	0	67	1	0	0	0	1	0	2	280
7:45:00 AM	3	90	0	0	93	104	10	55	0	169	0	90	16	0	106	1	0	0	0	0	1	0	368
8:00:00 AM	6	115	0	0	121	90	6	59	0	155	0	69	7	0	76	0	0	0	0	0	0	0	352
8:15:00 AM	4	83	0	0	87	70	1	61	0	132	0	52	6	0	58	0	0	0	0	0	0	0	277
Grand Total	18	355	0	0	373	350	20	226	0	596	0	271	36	0	307	1	0	0	0	1	0	2	1277
% Approach	4.8%	95.2%	0.0%	0.0%	0.0%	58.7%	3.4%	37.9%	0.0%	0.0%	0.0%	0.0%	88.3%	11.7%	0.0%	0.0%	0.0%	0.0%	0.0%	0.0%	0.0%	0.0%	0.0%
% Total	1.4%	27.8%	0.0%	0.0%	28.2%	27.4%	1.6%	17.7%	0.0%	46.7%	0.0%	0.0%	21.2%	2.8%	0.0%	24.0%	0.0%	0.0%	0.1%	0.0%	0.0%	0.0%	0.0%
PHF	0.750	0.772	0.000	0.000	0.771	0.841	0.500	0.926	0.000	0.882	0.000	0.000	0.753	0.563	0.000	0.724	0.000	0.000	0.250	0.000	0.000	0.250	0.000
Lights	16	327	0	0	343	350	19	219	0	588	0	253	31	0	284	0	0	0	0	1	0	0	1216
% Lights	88.9%	92.1%	0.0%	0.0%	92.0%	100.0%	95.0%	96.9%	0.0%	98.7%	0.0%	0.0%	93.4%	86.1%	0.0%	92.5%	0.0%	0.0%	100.0%	0.0%	0.0%	100.0%	95.2%
Trucks	0	0	0	0	0	0	0	2	0	2	0	0	0	0	0	0	0	0	0	0	0	0	2
% Trucks	0.0%	0.0%	0.0%	0.0%	0.0%	0.0%	0.0%	0.9%	0.0%	0.3%	0.0%	0.0%	0.0%	0.0%	0.0%	0.0%	0.0%	0.0%	0.0%	0.0%	0.0%	0.0%	0.2%
Buses	2	28	0	0	30	0	1	5	0	6	0	0	18	5	0	23	0	0	0	0	0	0	59
% Buses	11.1%	7.9%	0.0%	0.0%	8.0%	0.0%	5.0%	2.2%	0.0%	0.0%	0.0%	0.0%	6.8%	13.9%	0.0%	0.0%	0.0%	0.0%	0.0%	0.0%	0.0%	0.0%	4.8%
Pedestrians	0	0	0	0	0	0	0	0	0	0	0	0	0	0	0	1	0	0	0	0	0	1	2
% Pedestrians	0.0%	0.0%	0.0%	0.0%	0.0%	0.0%	0.0%	0.0%	0.0%	0.0%	0.0%	0.0%	0.0%	0.0%	0.0%	0.3%	100.0%	0.0%	0.0%	0.0%	0.0%	100.0%	100.0%
Bicycles on Crosswalk	0	0	0	0	0	0	0	0	0	0	0	0	0	0	0	0	0	0	0	0	0	0	0
% Bicycles on Crosswalk	0.0%	0.0%	0.0%	0.0%	0.0%	0.0%	0.0%	0.0%	0.0%	0.0%	0.0%	0.0%	0.0%	0.0%	0.0%	0.0%	0.0%	0.0%	0.0%	0.0%	0.0%	0.0%	0.0%

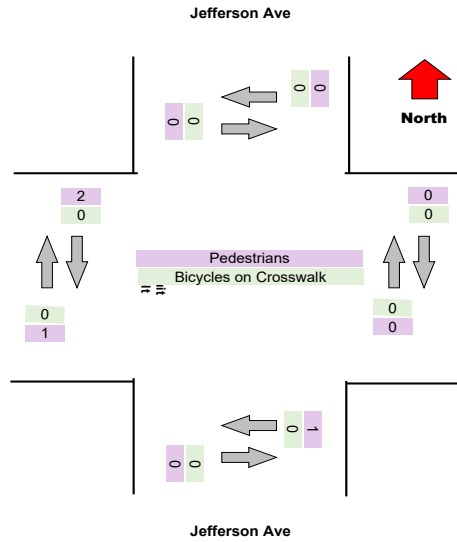
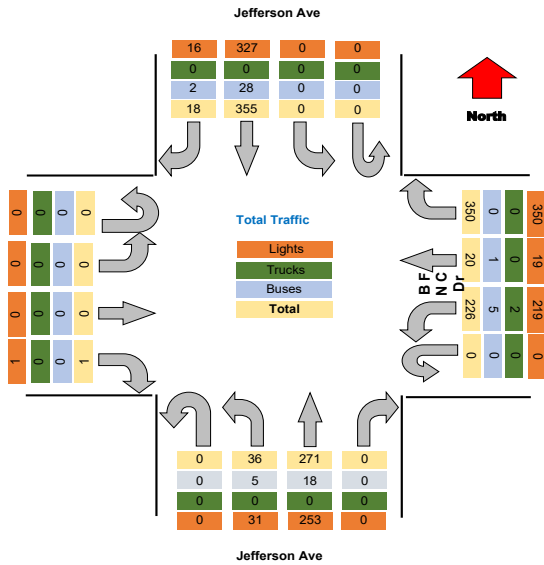

Turning Movement Peak Hour Data (PM)

4:15:00 PM

Leg Direction	Jefferson Ave					Fruit Belt					Jefferson Ave					B F N C Dr					Total									
	Southbound					Westbound					Northbound					Eastbound														
Start Time	Right	Thru	Left	U-Turn	App Total	Peds CW	Peds CCW	Right	Thru	Left	U-Turn	App Total	Peds CW	Peds CCW	Right	Thru	Left	U-Turn	App Total	Peds CW	Peds CCW	Right	Thru	Left	U-Turn	App Total	Peds CW	Peds CCW		
4:15:00 PM	6	184	0	0	190	0	0	23	4	60	0	87	0	0	0	72	10	0	82	0	0	0	0	0	0	0	2	1	359	
4:30:00 PM	4	192	0	0	196	0	0	27	3	45	0	75	0	0	0	72	11	0	83	0	0	0	0	0	0	0	1	0	354	
4:45:00 PM	3	146	0	0	149	0	0	16	2	64	0	82	0	0	0	67	8	0	75	0	0	0	0	0	0	0	0	0	306	
5:00:00 PM	4	154	0	0	158	0	0	22	2	40	0	64	0	0	0	76	10	0	86	0	0	0	0	0	0	0	0	0	316	
Grand Total	17	685	0	0	703	0	0	88	11	209	0	308	0	0	0	297	39	0	336	0	0	0	0	0	0	0	3	1	1337	
% Approach	2.4%	97.6%	0.0%	0.0%	0.0%	0.0%	0.0%	28.6%	3.6%	67.9%	0.0%	0.0%	0.0%	0.0%	0.0%	88.0%	12.0%	0.0%	0.0%	0.0%	0.0%	0.0%	0.0%	0.0%	0.0%	0.0%	0.0%	0.0%	0.0%	
% Total	1.3%	51.3%	0.0%	0.0%	52.6%	0.0%	0.0%	6.6%	0.8%	15.6%	0.0%	23.0%	0.0%	0.0%	0.0%	21.5%	2.9%	0.0%	24.4%	0.0%	0.0%	0.0%	0.0%	0.0%	0.0%	0.0%	0.0%	0.0%		
PHF	0.708	0.893	0.000	0.000	0.897	0.000	0.000	0.815	0.688	0.816	0.000	0.885	0.000	0.000	0.000	0.944	0.886	0.000	0.848	0.000	0.000	0.000	0.000	0.000	0.000	0.000	0.000	0.000	0.931	
Lights	17	670	0	0	687	0	0	86	11	207	0	304	0	0	0	278	38	0	316	0	0	0	0	0	0	0	0	0	1307	
% Lights	100.0%	97.7%	0.0%	0.0%	97.7%	0.0%	0.0%	97.7%	100.0%	99.0%	0.0%	98.7%	0.0%	0.0%	0.0%	96.0%	97.4%	0.0%	96.9%	0.0%	0.0%	0.0%	0.0%	0.0%	0.0%	0.0%	0.0%	0.0%	97.8%	
Trucks	0	0	0	0	0	0	0	0	0	0	0	0	0	0	0	0	0	0	0	0	0	0	0	0	0	0	0	0	0	
% Trucks	0.0%	0.0%	0.0%	0.0%	0.0%	0.0%	0.0%	0.0%	0.0%	0.0%	0.0%	0.0%	0.0%	0.0%	0.0%	0.0%	0.0%	0.0%	0.0%	0.0%	0.0%	0.0%	0.0%	0.0%	0.0%	0.0%	0.0%	0.0%	0.0%	
Buses	0	16	0	0	16	0	0	2	0	2	0	4	0	0	0	9	1	0	10	0	0	0	0	0	0	0	0	0	30	
% Buses	0.0%	2.3%	0.0%	0.0%	0.0%	0.0%	0.0%	2.3%	0.0%	1.0%	0.0%	0.0%	0.0%	0.0%	0.0%	3.1%	2.6%	0.0%	0.0%	0.0%	0.0%	0.0%	0.0%	0.0%	0.0%	0.0%	0.0%	0.0%	2.2%	
Pedestrians	0	0	0	0	0	0	0	0	0	0	0	0	1	0	0	0	0	0	0	0	0	0	0	0	0	0	1	1	0	
% Pedestrians	0.0%	0.0%	0.0%	0.0%	0.0%	0.0%	0.0%	0.0%	0.0%	0.0%	0.0%	0.0%	100.0%	0.0%	0.0%	0.0%	0.0%	0.0%	0.0%	0.0%	0.0%	0.0%	0.0%	0.0%	0.0%	0.0%	0.0%	33.3%	100.0%	0.0%
Bicycles on Crosswalk	0	0	0	0	0	0	0	0	0	0	0	0	0	0	0	0	0	0	0	0	0	0	0	0	0	0	2	0	0	
% Bicycles on Crosswalk	0.0%	0.0%	0.0%	0.0%	0.0%	0.0%	0.0%	0.0%	0.0%	0.0%	0.0%	0.0%	0.0%	0.0%	0.0%	0.0%	0.0%	0.0%	0.0%	0.0%	0.0%	0.0%	0.0%	0.0%	0.0%	0.0%	66.7%	0.0%	0.0%	

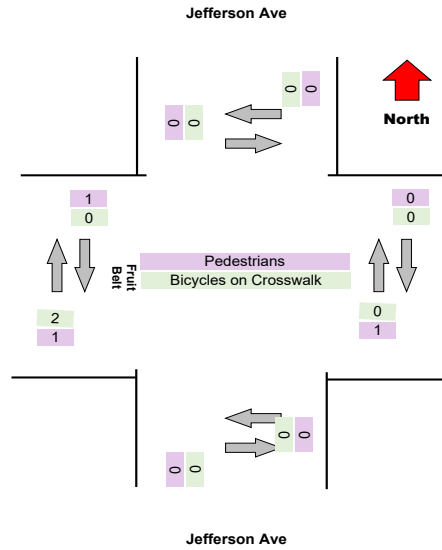
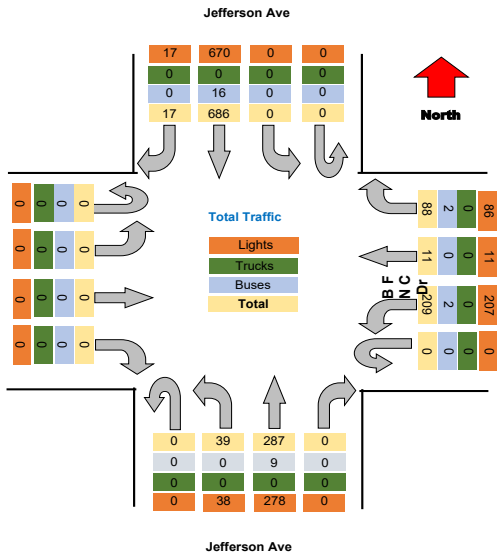

Project : VBH Malta NY
Site : Site 4
Location : 42.948550, -73.790036

TSTData.com

Survey Date : 2021-04-28, Wednesday

Project	LaBella
Project Code	LaBella
Site Name	11
Legs and Movements	All Processed Legs & Move
Bin Size	15 minutes
Survey Date	2021-11-04, Thursday
Location	11
Latitude and Longitude	42.897816, -78.853982

	Start	End	PHF
Forced Peak AM	2021/11/04 07:30:00	2021/11/04 08:30:00	0.86
Forced Peak PM	2021/11/04 16:30:00	2021/11/04 17:30:00	0.97
AM Peak	2021/11/04 07:30:00	2021/11/04 08:30:00	0.86
PM Peak	2021/11/04 16:15:00	2021/11/04 17:15:00	0.9

Turning Movement Data

Leg Direction	Jefferson Ave Southbound							Fruit Belt Westbound							Jefferson Ave Northbound							B F N C Dr Eastbound							Total	
	Right	Thru	Left	U-Turn	App Total	Peds CV	Peds CCV	Right	Thru	Left	U-Turn	App Total	Peds CV	Peds CCV	Right	Thru	Left	U-Turn	App Total	Peds CV	Peds CCV	Right	Thru	Left	U-Turn	App Total	Peds CV	Peds CCV		
6:30:00 AM	0	40	0	0	40	0	0	44	0	17	0	61	0	0	0	29	3	0	32	0	0	0	0	0	0	0	0	0	0	133
6:45:00 AM	3	32	0	0	35	0	0	73	2	36	0	111	0	0	0	44	3	0	47	0	0	0	0	0	0	0	0	0	0	193
Hourly Total	3	72	0	0	75	0	0	117	2	53	0	172	0	0	0	73	6	0	79	0	0	0	0	0	0	0	0	0	0	326
7:00:00 AM	2	52	0	0	54	0	0	45	0	24	0	69	0	0	0	44	4	0	48	0	0	0	0	0	0	0	0	0	0	171
7:15:00 AM	2	44	0	0	46	0	0	68	2	36	0	106	1	0	0	51	6	0	57	0	0	0	0	0	0	0	0	1	0	210
7:30:00 AM	5	66	0	0	71	0	0	90	2	59	0	151	0	0	0	61	13	0	74	0	0	0	0	0	0	0	0	0	1	296
7:45:00 AM	4	93	0	0	97	0	0	110	6	50	0	166	0	0	0	88	19	0	107	0	0	0	0	0	0	0	0	0	0	370
Hourly Total	13	255	0	0	268	0	0	313	10	169	0	492	1	0	0	244	42	0	287	0	0	0	0	0	0	0	1	1	1047	
8:00:00 AM	2	94	0	0	96	0	0	77	6	43	0	126	1	0	0	84	13	0	97	0	0	0	0	0	0	0	0	0	1	320
8:15:00 AM	3	92	0	0	95	0	0	65	5	60	0	130	1	0	0	58	8	0	66	0	0	0	0	0	0	0	1	0	292	
Hourly Total	5	186	0	0	191	0	0	142	11	103	0	256	2	0	0	142	21	0	163	0	0	0	0	0	0	0	1	1	612	
4:00:00 PM	5	212	0	0	217	0	0	24	2	63	0	89	0	0	0	52	2	0	54	0	0	0	63	0	0	0	0	2	0	360
4:15:00 PM	5	174	0	0	179	0	0	24	1	74	0	99	0	0	0	78	6	0	84	0	0	0	0	0	0	0	0	0	0	362
4:30:00 PM	8	162	0	0	170	0	0	21	4	44	0	69	2	2	0	66	15	0	81	0	0	0	0	0	0	0	0	0	0	320
4:45:00 PM	4	148	0	0	152	0	0	20	2	57	0	79	0	0	0	66	5	0	71	2	0	0	0	0	0	0	0	2	0	302
Hourly Total	22	696	0	0	718	0	0	89	9	238	0	338	2	2	0	252	28	0	280	2	0	0	0	0	0	0	2	2	1344	
5:00:00 PM	5	151	0	0	156	0	0	22	3	59	0	84	0	1	0	66	9	0	75	0	0	2	2	0	0	2	2	1	317	
5:15:00 PM	4	136	0	0	140	0	0	17	3	54	0	74	0	1	0	70	13	0	83	0	0	0	0	0	0	0	0	0	0	297
5:30:00 PM	9	125	0	0	134	0	0	22	0	43	0	65	0	1	0	63	9	0	72	0	0	0	0	0	0	0	0	1	0	271
5:45:00 PM	4	117	0	0	121	0	0	19	0	51	0	70	1	0	0	61	9	0	70	0	0	0	0	0	0	0	0	0	1	261
Hourly Total	22	529	0	0	551	0	0	80	6	207	0	293	1	3	0	280	40	0	300	0	0	2	2	0	0	2	3	2	1146	
Grand Total	65	1738	0	0	1803	0	0	741	38	770	0	1549	6	6	0	981	137	0	1121	2	0	2	2	0	0	2	7	6	4475	
% Approach	3.6%	96.4%	0.0%	0.0%	0.0%	0.0%	0.0%	47.8%	2.5%	49.7%	0.0%	0.0%	0.0%	0.0%	0.0%	87.5%	12.2%	0.0%	0.0%	0.0%	0.0%	100.0%	0.0%	0.0%	0.0%	0.0%	0.0%	0.0%	0.0%	0.0%
% Total	1.5%	38.8%	0.0%	0.0%	40.3%	0.0%	0.0%	16.6%	0.8%	17.2%	0.0%	34.6%	0.0%	0.0%	0.0%	21.9%	3.1%	0.0%	25.1%	0.0%	0.0%	0.0%	0.0%	0.0%	0.0%	0.0%	0.0%	0.0%	0.0%	0.0%
Lights	62	1678	0	0	1740	0	0	736	35	757	0	1528	0	0	0	932	132	0	1064	0	0	2	2	0	0	2	0	0	4334	
% Lights	95.4%	96.5%	0.0%	0.0%	96.5%	0.0%	0.0%	99.3%	92.1%	98.3%	0.0%	98.6%	0.0%	0.0%	0.0%	95.0%	96.4%	0.0%	94.9%	0.0%	0.0%	100.0%	0.0%	0.0%	0.0%	100.0%	0.0%	0.0%	96.8%	
Trucks	0	0	0	0	0	0	0	1	0	0	0	1	0	0	0	4	0	0	4	0	0	0	0	0	0	0	0	0	5	
% Trucks	0.0%	0.0%	0.0%	0.0%	0.0%	0.0%	0.0%	0.1%	0.0%	0.0%	0.0%	0.1%	0.0%	0.0%	0.0%	0.4%	0.0%	0.0%	0.4%	0.0%	0.0%	0.0%	0.0%	0.0%	0.0%	0.0%	0.0%	0.0%	0.1%	
Buses	3	69	0	0	72	0	0	4	3	13	0	20	0	0	0	44	5	0	49	0	0	0	0	0	0	0	0	0	0	131
% Buses	4.6%	3.4%	0.0%	0.0%	0.0%	0.0%	0.0%	0.0%	7.9%	1.7%	0.0%	0.0%	0.0%	0.0%	0.0%	4.5%	3.6%	0.0%	0.0%	0.0%	0.0%	0.0%	0.0%	0.0%	0.0%	0.0%	0.0%	0.0%	2.9%	
Pedestrians	0	0	0	0	0	0	0	0	0	0	0	0	6	4	0	0	0	0	0	2	0	0	0	0	0	0	0	6	5	0
% Pedestrians	0.0%	0.0%	0.0%	0.0%	0.0%	0.0%	0.0%	0.0%	0.0%	0.0%	0.0%	0.0%	100.0%	80.0%	0.0%	0.0%	0.0%	0.0%	0.0%	100.0%	0.0%	0.0%	0.0%	0.0%	0.0%	0.0%	0.0%	85.7%	83.3%	0.0%
Bicycles on Crosswalk	0	0	0	0	0	0	0	0	0	0	0	0	0	1	0	0	0	0	0	0	0	0	0	0	0	0	0	1	1	0
% Bicycles on Crosswalk	0.0%	0.0%	0.0%	0.0%	0.0%	0.0%	0.0%	0.0%	0.0%	0.0%	0.0%	0.0%	0.0%	20.0%	0.0%	0.0%	0.0%	0.0%	0.0%	0.0%	0.0%	0.0%	0.0%	0.0%	0.0%	0.0%	0.0%	14.3%	16.7%	0.0%

Turning Movement Data Plot

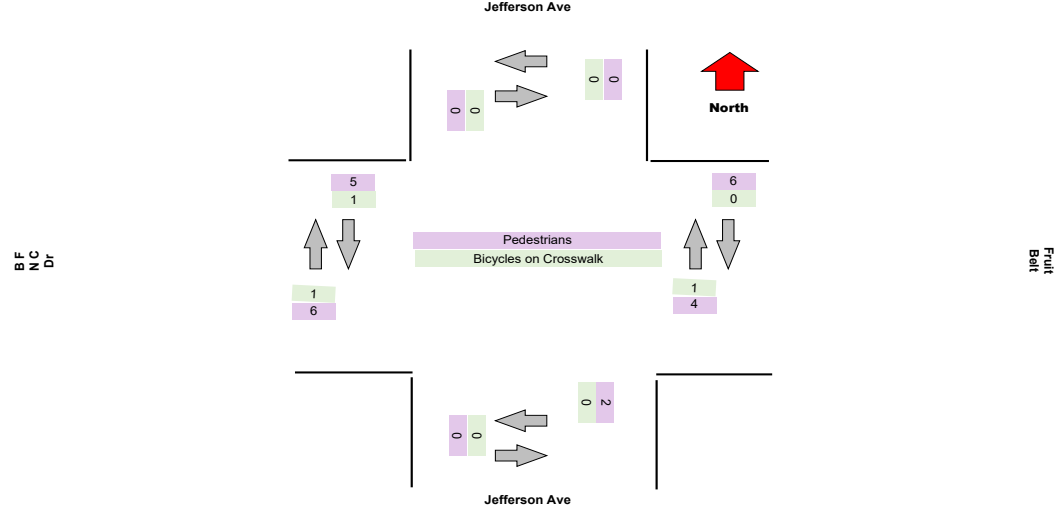
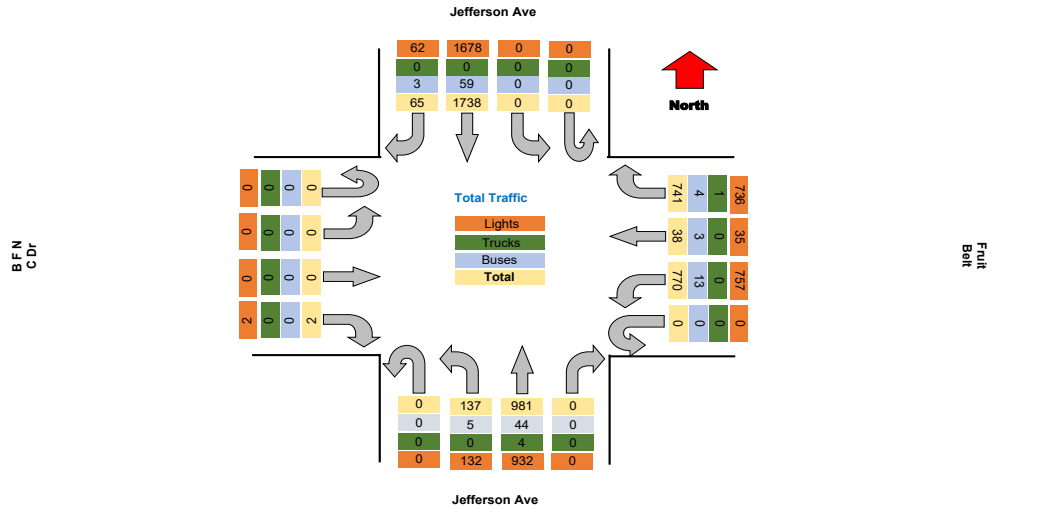

Project : VBH Malta NY
Site : Site 4
Location : 42.948550, -73.790036

TSTData.com

Survey Date : 2021-04-28, Wednesday

Turning Movement Peak Hour Data (AM)

7:30:00 AM

Leg Direction	Jefferson Ave					Fruit Belt					Jefferson Ave					B F N C Dr					Total								
	Southbound					Westbound					Northbound					Eastbound													
Start Time	Right	Thru	Left	U-Turn	App Total	Peds CW	Peds CCW	Right	Thru	Left	U-Turn	App Total	Peds CW	Peds CCW	Right	Thru	Left	U-Turn	App Total	Peds CW	Peds CCW	Right	Thru	Left	U-Turn	App Total	Peds CW	Peds CCW	
7:30:00 AM	5	66	0	0	71	0	0	90	2	59	0	151	0	0	0	61	13	0	74	0	0	0	0	0	0	0	0	1	296
7:45:00 AM	4	93	0	0	97	0	0	110	6	50	0	166	0	0	0	88	19	0	107	0	0	0	0	0	0	0	0	1	370
8:00:00 AM	2	94	0	0	96	0	0	77	6	43	0	126	1	0	0	84	13	0	98	0	0	0	0	0	0	0	0	1	320
8:15:00 AM	3	92	0	0	95	0	0	65	5	69	0	139	1	0	0	58	8	0	67	0	0	0	0	0	0	0	1	292	
Grand Total	14	345	0	0	359	0	0	342	19	212	0	573	2	0	0	291	53	0	346	0	0	0	0	0	0	0	1	1278	
% Approach	3.9%	96.1%	0.0%	0.0%	0.0%	0.0%	0.0%	59.7%	3.3%	37.0%	0.0%	0.0%	0.0%	0.0%	0.0%	84.1%	15.3%	0.0%	0.0%	0.0%	0.0%	#DIV/0!	#DIV/0!	#DIV/0!	###	0.0%	0.0%	0.0%	
% Total	1.1%	27.0%	0.0%	0.0%	28.1%	0.0%	0.0%	26.8%	1.5%	16.6%	0.0%	44.8%	0.0%	0.0%	0.0%	22.8%	4.1%	0.0%	27.1%	0.0%	0.0%	0.0%	0.0%	0.0%	0.0%	0.0%	0.0%	0.0%	
PHF	0.700	0.918	0.000	0.000	0.925	0.000	0.000	0.777	0.792	0.883	0.000	0.863	0.000	0.000	0.000	0.827	0.697	0.000	0.808	0.000	0.000	0.000	0.000	0.000	0.000	0.000	0.000	0.864	
Lights	12	320	0	0	332	0	0	342	17	207	0	566	0	0	0	272	49	0	321	0	0	0	0	0	0	0	0	1219	
% Lights	85.7%	92.8%	0.0%	0.0%	92.5%	0.0%	0.0%	100.0%	89.5%	97.6%	0.0%	98.8%	0.0%	0.0%	0.0%	93.5%	92.5%	0.0%	92.8%	0.0%	0.0%	0.0%	0.0%	0.0%	0.0%	0.0%	0.0%	95.4%	
Trucks	0	0	0	0	0	0	0	0	0	0	0	0	0	0	0	2	0	0	2	0	0	0	0	0	0	0	0	2	
% Trucks	0.0%	0.0%	0.0%	0.0%	0.0%	0.0%	0.0%	0.0%	0.0%	0.0%	0.0%	0.0%	0.0%	0.0%	0.0%	0.7%	0.0%	0.0%	0.6%	0.0%	0.0%	0.0%	0.0%	0.0%	0.0%	0.0%	0.0%	0.2%	
Buses	2	25	0	0	27	0	0	0	2	5	0	7	0	0	0	17	4	0	21	0	0	0	0	0	0	0	0	55	
% Buses	14.3%	7.2%	0.0%	0.0%	0.0%	0.0%	0.0%	0.0%	10.5%	2.4%	0.0%	0.0%	0.0%	0.0%	0.0%	5.8%	7.5%	0.0%	0.0%	0.0%	0.0%	0.0%	0.0%	0.0%	0.0%	0.0%	0.0%	4.3%	
Pedestrians	0	0	0	0	0	0	0	0	0	0	0	0	2	0	0	0	0	0	0	0	0	0	0	0	0	0	1	2	
% Pedestrians	0.0%	0.0%	0.0%	0.0%	0.0%	0.0%	0.0%	0.0%	0.0%	0.0%	0.0%	0.0%	100.0%	0.0%	0.0%	0.0%	0.0%	0.0%	0.0%	0.0%	0.0%	0.0%	0.0%	0.0%	0.0%	0.0%	0.0%	100.0%	
Bicycles on Crosswalk	0	0	0	0	0	0	0	0	0	0	0	0	0	0	0	0	0	0	0	0	0	0	0	0	0	0	0	0	
% Bicycles on Crosswalk	0.0%	0.0%	0.0%	0.0%	0.0%	0.0%	0.0%	0.0%	0.0%	0.0%	0.0%	0.0%	0.0%	0.0%	0.0%	0.0%	0.0%	0.0%	0.0%	0.0%	0.0%	0.0%	0.0%	0.0%	0.0%	0.0%	0.0%	0.0%	

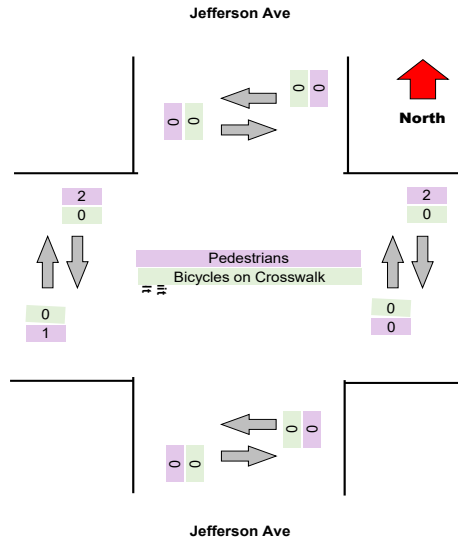
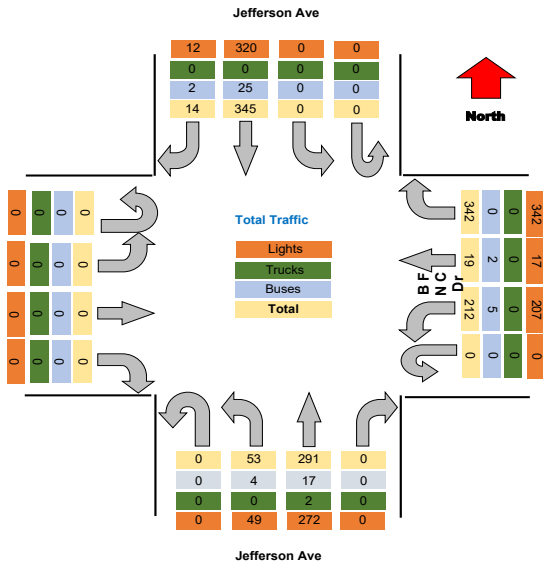

Turning Movement Peak Hour Data (PM)

4:15:00 PM

Leg Direction	Jefferson Ave				Fruit Belt				Jefferson Ave				B F N C Dr				Total					
	Southbound				Westbound				Northbound				Eastbound									
Start Time	Right	Thru	Left	U-Turn	App Total	Peds CW	Peds CCW	Right	Thru	Left	U-Turn	App Total	Peds CW	Peds CCW	Right	Thru	Left	U-Turn	App Total	Peds CW	Peds CCW	
4:15:00 PM	5	174	0	0	179	0	0	24	1	74	0	99	0	0	0	78	6	0	84	0	0	0
4:30:00 PM	8	162	0	0	170	0	0	21	4	44	0	69	2	2	0	66	15	0	81	0	0	0
4:45:00 PM	4	148	0	0	152	0	0	20	2	57	0	79	0	0	0	66	5	0	71	2	0	0
5:00:00 PM	5	151	0	0	156	0	0	22	3	59	0	84	0	0	0	66	9	0	75	0	0	0
Grand Total	22	635	0	0	657	0	0	87	10	234	0	331	2	2	0	276	35	0	311	2	0	2
% Approach	3.3%	96.7%	0.0%	0.0%	0.0%	0.0%	0.0%	26.3%	3.0%	70.7%	0.0%	0.0%	0.0%	0.0%	0.0%	88.7%	11.3%	0.0%	0.0%	0.0%	0.0%	0.0%
% Total	1.7%	48.8%	0.0%	0.0%	50.5%	0.0%	0.0%	6.7%	0.8%	18.0%	0.0%	25.4%	0.0%	0.0%	0.0%	21.2%	2.7%	0.0%	23.9%	0.0%	0.0%	0.0%
PHF	0.688	0.912	0.000	0.000	0.918	0.000	0.000	0.906	0.625	0.791	0.000	0.836	0.000	0.000	0.000	0.885	0.583	0.000	0.826	0.000	0.000	0.000
Lights	22	620	0	0	642	0	0	85	10	229	0	324	0	0	0	264	35	0	299	0	0	2
% Lights	100.0%	97.6%	0.0%	0.0%	97.7%	0.0%	0.0%	97.7%	100.0%	97.9%	0.0%	97.9%	0.0%	0.0%	0.0%	95.7%	100.0%	0.0%	96.1%	0.0%	0.0%	100.0%
Trucks	0	0	0	0	0	0	0	0	0	0	0	0	0	0	0	1	0	0	1	0	0	0
% Trucks	0.0%	0.0%	0.0%	0.0%	0.0%	0.0%	0.0%	0.0%	0.0%	0.0%	0.0%	0.0%	0.0%	0.0%	0.0%	0.4%	0.0%	0.0%	0.3%	0.0%	0.0%	0.0%
Buses	0	15	0	0	15	0	0	2	0	5	0	7	0	0	0	10	0	0	10	0	0	0
% Buses	0.0%	2.4%	0.0%	0.0%	0.0%	0.0%	0.0%	2.3%	0.0%	2.1%	0.0%	0.0%	0.0%	0.0%	0.0%	3.6%	0.0%	0.0%	0.0%	0.0%	0.0%	0.0%
Pedestrians	0	0	0	0	0	0	0	0	0	0	0	2	3	0	0	0	0	0	0	2	3	0
% Pedestrians	0.0%	0.0%	0.0%	0.0%	0.0%	0.0%	0.0%	0.0%	0.0%	0.0%	0.0%	0.6%	100.0%	100.0%	0.0%	0.0%	0.0%	0.0%	0.0%	0.6%	100.0%	100.0%
Bicycles on Crosswalk	0	0	0	0	0	0	0	0	0	0	0	0	0	0	0	0	0	0	0	0	0	0
% Bicycles on Crosswalk	0.0%	0.0%	0.0%	0.0%	0.0%	0.0%	0.0%	0.0%	0.0%	0.0%	0.0%	0.0%	0.0%	0.0%	0.0%	0.0%	0.0%	0.0%	0.0%	0.0%	0.0%	0.0%

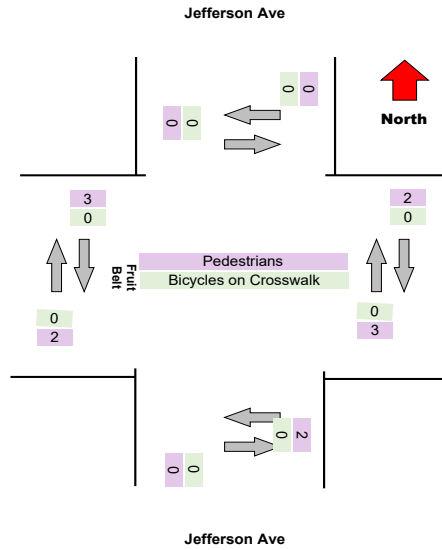
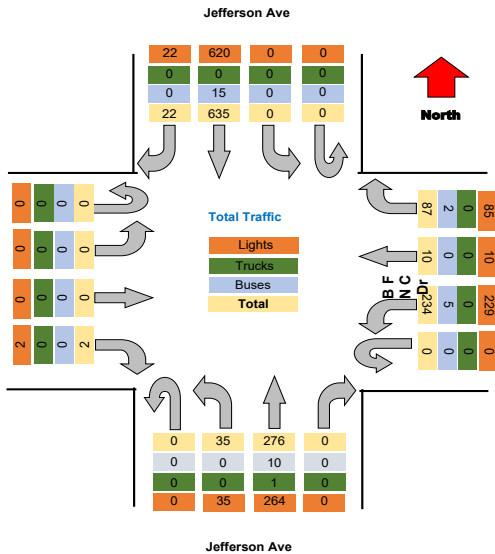

Project : VBH Malta NY
 Site : Site 4
 Location : 42.948550, -73.790036
 Survey Date : 2021-04-28, Wednesday

Turning Movement Data Plot

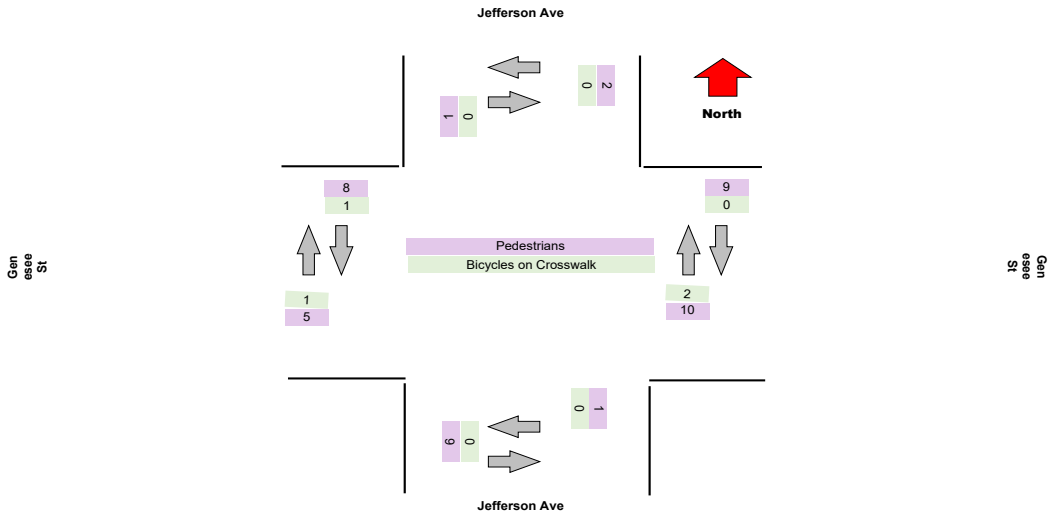
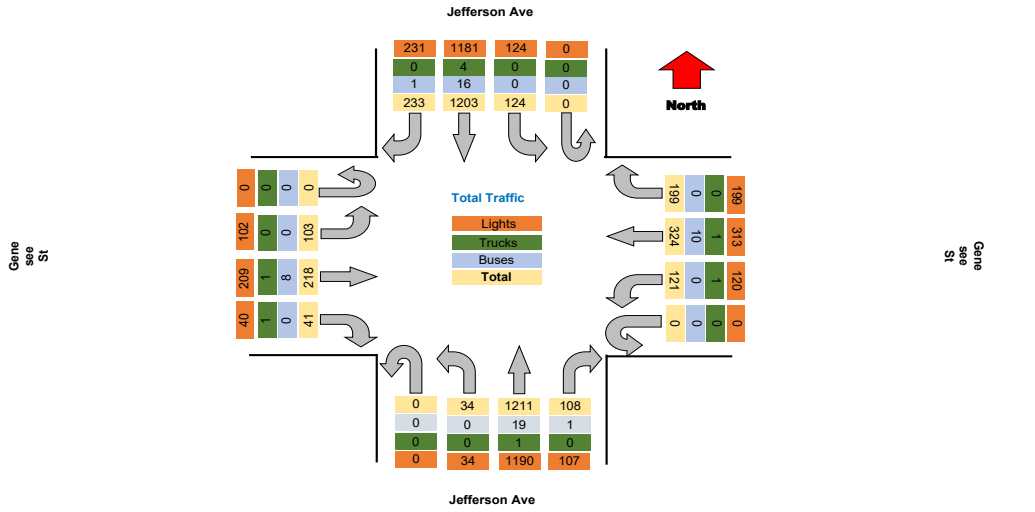

Turning Movement Peak Hour Data (AM)

7:30:00 AM

Leg Direction	Jefferson Ave					Genesee St					Jefferson Ave					Genesee St					Total								
	Southbound		Northbound			Westbound		Eastbound			Northbound		Eastbound			Northbound		Eastbound											
Start Time	Right	Thru	Left	U-Turn	App Total	Peds CW	Peds CCW	Right	Thru	Left	U-Turn	App Total	Peds CW	Peds CCW	Right	Thru	Left	U-Turn	App Total	Peds CW	Peds CCW	Right	Thru	Left	U-Turn	App Total	Peds CW	Peds CCW	
7:30:00 AM	6	44	4	0	54	0	0	13	19	1	0	33	0	0	4	79	1	0	84	0	2	1	4	1	0	6	2	0	177
7:45:00 AM	6	65	7	0	78	0	0	14	20	10	0	44	0	0	2	59	2	0	63	0	2	2	11	4	0	17	0	0	202
8:00:00 AM	11	67	3	0	81	0	0	11	22	9	0	42	0	0	0	68	4	0	72	0	0	0	12	3	0	15	0	1	210
8:15:00 AM	7	68	8	0	83	0	0	15	26	5	0	46	1	1	6	49	2	0	59	0	2	0	13	0	0	13	0	0	201
Grand Total	30	244	22	0	296	0	0	53	87	25	0	155	1	1	12	255	9	0	273	0	6	3	40	8	0	51	2	1	790
% Approach	10.1%	82.4%	7.4%	0.0%	0.0%	0.0%	0.0%	32.1%	52.7%	15.2%	0.0%	0.0%	0.0%	0.0%	4.3%	91.7%	3.2%	0.0%	0.0%	0.0%	0.0%	5.9%	75.4%	15.7%	0.0%	0.0%	0.0%	0.0%	17.7%
% Total	3.8%	30.9%	2.8%	0.0%	37.5%	0.0%	0.0%	6.7%	11.0%	3.2%	0.0%	20.9%	0.0%	0.0%	1.5%	32.3%	1.1%	0.0%	35.2%	0.0%	0.0%	0.4%	5.1%	1.0%	0.0%	6.5%	0.0%	0.0%	1.8%
PHF	0.682	0.897	0.688	0.000	0.892	0.000	0.000	0.883	0.837	0.625	0.000	0.897	0.000	0.000	0.500	0.807	0.563	0.000	0.827	0.000	0.000	0.375	0.769	0.500	0.000	0.750	0.000	0.000	0.940
Lights	29	238	22	0	289	0	0	53	85	24	0	162	0	0	12	252	9	0	273	0	0	3	37	8	0	48	0	0	772
% Lights	96.7%	97.5%	100.0%	0.0%	97.6%	0.0%	0.0%	100.0%	97.7%	96.0%	0.0%	98.2%	0.0%	0.0%	100.0%	98.8%	100.0%	0.0%	98.2%	0.0%	0.0%	100.0%	92.5%	100.0%	0.0%	94.1%	0.0%	0.0%	97.7%
Trucks	0	0	0	0	0	0	0	0	0	1	0	1	0	0	0	0	0	0	0	0	0	0	1	0	0	1	0	0	2
% Trucks	0.0%	0.0%	0.0%	0.0%	0.0%	0.0%	0.0%	0.0%	0.0%	4.0%	0.0%	0.6%	0.0%	0.0%	0.0%	0.0%	0.0%	0.0%	0.0%	0.0%	0.0%	0.0%	2.5%	0.0%	0.0%	2.0%	0.0%	0.0%	0.3%
Buses	0	5	0	0	5	0	0	0	2	0	0	2	0	0	0	3	0	0	3	0	0	0	2	0	0	2	0	0	12
% Buses	0.0%	2.0%	0.0%	0.0%	0.0%	0.0%	0.0%	0.0%	2.3%	0.0%	0.0%	0.0%	0.0%	0.0%	0.0%	1.2%	0.0%	0.0%	0.0%	0.0%	0.0%	0.0%	5.0%	0.0%	0.0%	0.0%	0.0%	0.0%	1.5%
Pedestrians	0	0	0	0	0	0	0	0	0	0	0	0	1	1	0	0	0	0	0	0	6	0	0	0	0	0	2	1	0
% Pedestrians	0.0%	0.0%	0.0%	0.0%	0.0%	0.0%	0.0%	0.0%	0.0%	0.0%	0.0%	0.0%	100.0%	100.0%	0.0%	0.0%	0.0%	0.0%	0.0%	0.0%	100.0%	0.0%	0.0%	0.0%	0.0%	0.0%	100.0%	100.0%	0.0%
Bicycles on Crosswalk	0	0	0	0	0	0	0	0	0	0	0	0	0	0	0	0	0	0	0	0	0	0	0	0	0	0	0	0	0
% Bicycles on Crosswalk	0.0%	0.0%	0.0%	0.0%	0.0%	0.0%	0.0%	0.0%	0.0%	0.0%	0.0%	0.0%	0.0%	0.0%	0.0%	0.0%	0.0%	0.0%	0.0%	0.0%	0.0%	0.0%	0.0%	0.0%	0.0%	0.0%	0.0%	0.0%	0.0%

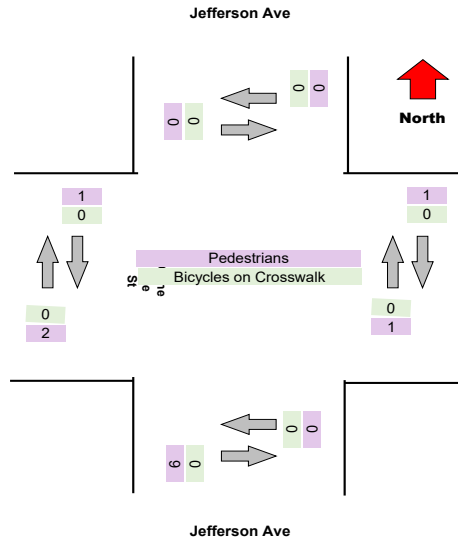
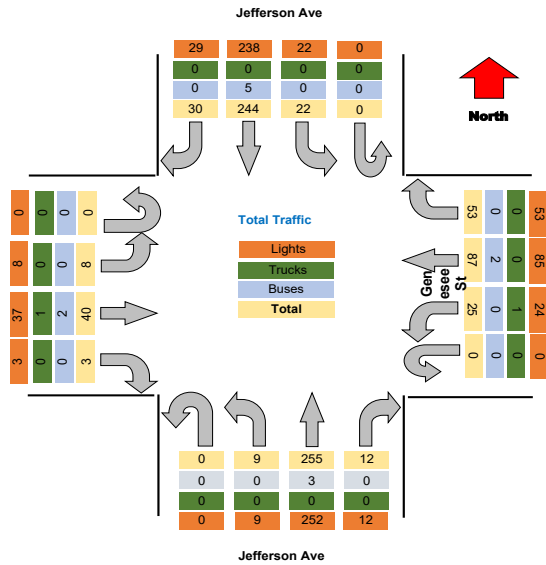

Project : VBH Malta NY
Site : Site 4
Location : 42.948550, -73.790036

TSTData.com

Survey Date : 2021-04-28, Wednesday

Turning Movement Peak Hour Data (PM)

4:15:00 PM

Leg Direction	Jefferson Ave								Genesee St								Jefferson Ave								Genesee St								Total
	Southbound				Westbound				Northbound				Eastbound				Southbound				Westbound				Northbound				Eastbound				
	Right	Thru	Left	U-Turn	App Total	Peds CW	Peds CCW		Right	Thru	Left	U-Turn	App Total	Peds CW	Peds CCW		Right	Thru	Left	U-Turn	App Total	Peds CW	Peds CCW		Right	Thru	Left	U-Turn	App Total	Peds CW	Peds CCW		
4:15:00 PM	19	111	11	0	141	0	0		17	20	14	0	51	1	1		4	88	6	0	98	0	0		6	17	13	0	36	0	0		326
4:30:00 PM	14	119	7	0	140	0	0		14	26	9	0	49	0	4		7	91	1	0	99	0	0		4	19	9	0	32	0	0		320
4:45:00 PM	21	114	7	0	142	0	0		15	16	10	0	41	2	1		17	96	2	0	115	1	0		5	16	7	0	28	2	0		326
5:00:00 PM	18	84	16	0	118	0	0		13	19	8	0	41	0	0		12	117	2	0	131	0	0		6	31	16	0	53	1	1		343
Grand Total	72	428	41	0	541	0	0		59	81	42	0	182	3	6		40	392	11	0	443	1	0		21	83	45	0	149	3	1		1315
% Approach	13.3%	79.1%	7.6%	0.0%	0.0%	0.0%	0.0%		32.4%	44.5%	23.1%	0.0%	0.0%	0.0%	0.0%		9.0%	98.5%	2.5%	0.0%	0.0%	0.0%	0.0%		14.1%	55.7%	30.2%	0.0%	0.0%	0.0%	0.0%		
% Total	5.5%	32.5%	3.1%	0.0%	41.1%	0.0%	0.0%		4.5%	6.2%	3.2%	0.0%	13.8%	0.0%	0.0%		3.0%	29.8%	0.8%	0.0%	33.7%	0.0%	0.0%		1.6%	6.3%	3.4%	0.0%	11.3%	0.0%	0.0%		
PHF	0.857	0.899	0.641	0.000	0.952	0.000	0.000		0.868	0.779	0.750	0.000	0.892	0.000	0.000		0.588	0.838	0.458	0.000	0.845	0.000	0.000		0.875	0.669	0.703	0.000	0.703	0.000	0.000		0.958
Lights	72	422	41	0	535	0	0		59	78	42	0	179	0	0		40	386	11	0	437	0	0		21	81	44	0	146	0	0		1297
% Lights	100.0%	98.6%	100.0%	0.0%	98.9%	0.0%	0.0%		100.0%	96.3%	100.0%	0.0%	98.4%	0.0%	0.0%		100.0%	98.5%	100.0%	0.0%	98.6%	0.0%	0.0%		100.0%	97.6%	97.8%	0.0%	98.0%	0.0%	0.0%		98.6%
Trucks	0	1	0	0	1	0	0		0	0	0	0	0	0	0		0	0	0	0	0	0	0		0	0	0	0	0	0	0		1
% Trucks	0.0%	0.2%	0.0%	0.0%	0.2%	0.0%	0.0%		0.0%	0.0%	0.0%	0.0%	0.0%	0.0%	0.0%		0.0%	0.0%	0.0%	0.0%	0.0%	0.0%	0.0%		0.0%	0.0%	0.0%	0.0%	0.0%	0.0%	0.0%		0.1%
Buses	0	4	0	0	4	0	0		0	3	0	0	3	0	0		0	5	0	0	5	0	0		0	2	0	0	2	0	0		14
% Buses	0.0%	0.9%	0.0%	0.0%	0.0%	0.0%	0.0%		0.0%	3.7%	0.0%	0.0%	0.0%	0.0%	0.0%		0.0%	1.3%	0.0%	0.0%	0.0%	0.0%	0.0%		0.0%	2.4%	0.0%	0.0%	0.0%	0.0%	0.0%		1.1%
Pedestrians	0	0	0	0	0	0	0		0	0	0	0	3	6		0	0	0	1	1	0	0	0	0	0	0	0	0	2	1	0	1	
% Pedestrians	0.0%	0.0%	0.0%	0.0%	0.0%	0.0%	0.0%		0.0%	0.0%	0.0%	0.0%	0.0%	100.0%	100.0%		0.0%	0.0%	0.0%	0.0%	0.0%	100.0%	0.0%	0.0%	0.0%	0.0%	0.0%	66.7%	100.0%	0.0%		0.8%	
Bicycles on Crosswalk	0	0	0	0	0	0	0		0	0	0	0	0	0	0		0	0	0	0	0	0	0	0	0	0	0	0	0	1	0		0
% Bicycles on Crosswalk	0.0%	0.0%	0.0%	0.0%	0.0%	0.0%	0.0%		0.0%	0.0%	0.0%	0.0%	0.0%	0.0%	0.0%		0.0%	0.0%	0.0%	0.0%	0.0%	0.0%	0.0%		0.0%	0.0%	0.0%	0.0%	0.0%	33.3%	0.0%		0.0%

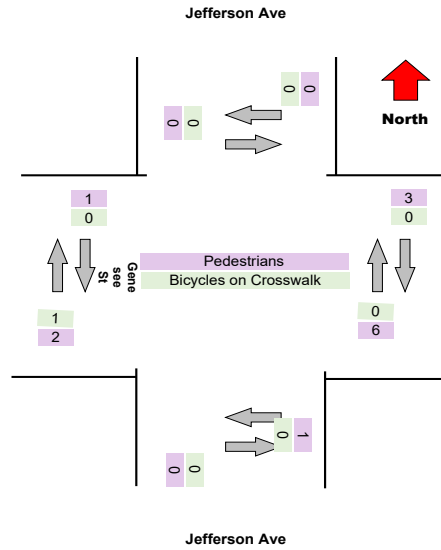
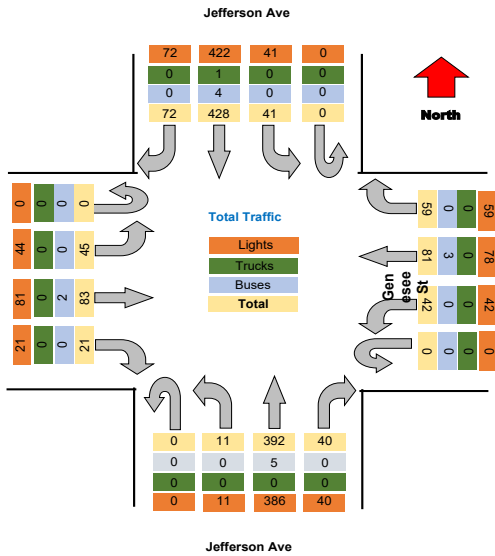

Project : VBH Malta NY
 Site : Site 4
 Location : 42.948550, -73.790036

TSTData.com

Survey Date : 2021-04-28, Wednesday

Project	LaBella
Project Code	LaBella
Site Name	12
Legs and Movements	All Processed Legs & Move
Bin Size	15 minutes
Survey Date	2021-11-03, Wednesday
Location	12
Latitude and Longitude	42.896155, -78.853968

	Start	End	PHF
Forced Peak AM	2021/11/03 07:30:00	2021/11/03 08:30:00	0.89
Forced Peak PM	2021/11/03 16:30:00	2021/11/03 17:30:00	0.94
AM Peak	2021/11/03 07:30:00	2021/11/03 08:30:00	0.89
PM Peak	2021/11/03 16:15:00	2021/11/03 17:15:00	0.93

Turning Movement Data

Leg Direction	Jefferson Ave							Genesee St							Jefferson Ave							Genesee St							Total
	Southbound							Westbound							Northbound							Eastbound							
	Right	Thru	Left	U-Turn	App Total	Peds CW	Peds CCW	Right	Thru	Left	U-Turn	App Total	Peds CW	Peds CCW	Right	Thru	Left	U-Turn	App Total	Peds CW	Peds CCW	Right	Thru	Left	U-Turn	App Total	Peds CW	Peds CCW	
6:30:00 AM	5	33	0	0	38	0	0	3	10	2	0	15	0	0	3	39	1	0	43	0	0	1	5	4	0	10	0	1	106
6:45:00 AM	4	46	3	0	53	0	0	16	14	6	0	36	0	0	5	50	0	0	55	0	0	0	4	5	0	9	0	1	153
Hourly Total	9	79	3	0	91	0	0	19	24	8	0	51	0	0	8	89	1	0	98	0	0	1	9	9	0	19	0	2	259
7:00:00 AM	7	45	4	0	56	1	0	12	17	11	0	39	2	0	3	58	0	0	63	0	0	3	6	2	0	11	0	0	160
7:15:00 AM	11	60	5	0	76	0	0	11	13	3	0	27	1	0	4	77	1	0	83	2	0	4	6	5	0	15	1	1	201
7:30:00 AM	11	75	7	0	93	0	0	18	28	4	0	50	0	0	3	94	3	0	100	0	2	0	10	8	0	18	0	1	261
7:45:00 AM	12	96	6	0	114	0	0	22	45	11	0	78	0	1	7	117	0	0	125	0	0	2	16	10	0	28	0	0	345
Hourly Total	41	276	22	0	339	1	0	63	103	19	0	185	3	1	17	346	4	0	371	2	2	9	38	25	0	72	1	2	967
8:00:00 AM	21	111	3	0	135	0	1	16	40	8	0	65	0	0	8	84	4	0	96	0	0	4	28	8	0	40	0	0	336
8:15:00 AM	16	94	9	0	119	0	0	10	37	10	0	57	0	0	4	83	0	0	87	0	0	3	19	5	0	27	0	0	290
Hourly Total	37	205	12	0	254	0	1	26	77	18	0	122	0	0	12	167	4	0	183	0	0	7	47	13	0	67	0	0	626
4:00:00 PM	26	122	8	0	156	0	0	14	34	8	0	56	0	0	13	123	1	0	137	1	0	2	45	15	0	62	0	1	411
4:15:00 PM	23	125	14	0	162	0	0	16	40	8	0	64	0	0	6	135	3	0	144	2	0	11	26	11	0	48	3	4	418
4:30:00 PM	24	124	12	0	160	1	0	24	29	16	0	71	0	0	8	109	1	0	118	0	0	8	29	8	0	45	0	0	394
4:45:00 PM	26	103	9	0	139	0	0	17	24	11	0	52	0	0	15	108	3	0	126	1	0	3	30	8	0	41	1	0	357
Hourly Total	99	474	43	0	616	1	0	71	127	45	0	243	0	0	42	475	8	0	525	4	0	24	130	42	0	196	4	5	1580
5:00:00 PM	30	110	9	0	149	0	0	11	25	9	0	45	1	0	13	133	3	0	149	0	0	6	25	9	0	40	1	0	383
5:15:00 PM	30	108	11	0	149	0	0	9	33	7	0	49	2	0	6	100	2	0	108	3	1	5	26	15	0	46	2	1	352
5:30:00 PM	29	90	12	0	131	0	0	12	22	9	0	43	0	1	10	114	5	0	129	1	0	5	18	10	0	33	1	0	336
5:45:00 PM	24	88	11	0	123	0	0	9	24	12	0	45	1	0	8	87	4	0	99	1	0	5	19	8	0	32	0	0	299
Hourly Total	113	396	43	0	552	0	0	41	104	37	0	182	4	1	37	434	14	0	485	5	1	21	88	42	0	151	4	1	1370
Grand Total	299	1430	123	0	1852	2	1	220	435	127	0	783	7	2	116	1511	31	0	1662	11	3	62	312	131	0	505	9	10	4502
% Approach	16.1%	77.2%	6.6%	0.0%	0.0%	0.0%	0.0%	28.1%	55.6%	16.2%	0.0%	0.0%	0.0%	0.0%	7.0%	90.9%	1.9%	0.0%	0.0%	0.0%	0.0%	12.3%	61.8%	25.9%	0.0%	0.0%	0.0%	0.0%	0.0%
% Total	6.2%	29.8%	2.6%	0.0%	38.6%	0.0%	0.0%	4.6%	8.1%	2.6%	0.0%	16.3%	0.0%	0.0%	2.4%	31.5%	0.6%	0.0%	34.6%	0.0%	0.0%	1.3%	6.5%	2.7%	0.0%	10.5%	0.0%	0.0%	0.0%
Lights	298	1363	116	0	1777	0	0	212	417	117	0	746	0	0	113	1458	30	0	1601	0	0	57	294	127	0	478	0	0	4602
% Lights	99.7%	95.3%	94.3%	0.0%	96.0%	0.0%	0.0%	95.4%	95.9%	92.1%	0.0%	95.3%	0.0%	0.0%	97.4%	96.5%	96.8%	0.0%	96.3%	0.0%	0.0%	91.9%	94.2%	96.9%	0.0%	94.7%	0.0%	0.0%	95.8%
Trucks	0	3	0	0	3	0	0	0	2	1	0	3	0	0	0	3	1	0	4	0	0	0	0	0	0	0	0	0	10
% Trucks	0.0%	0.2%	0.0%	0.0%	0.2%	0.0%	0.0%	0.0%	0.5%	0.8%	0.0%	0.4%	0.0%	0.0%	0.0%	0.2%	3.2%	0.0%	0.2%	0.0%	0.0%	0.0%	0.0%	0.0%	0.0%	0.0%	0.0%	0.0%	0.2%
Buses	1	64	7	0	72	0	0	8	15	7	0	30	0	0	3	50	0	0	53	0	0	5	18	3	0	26	0	0	181
% Buses	0.3%	4.5%	5.7%	0.0%	0.0%	0.0%	0.0%	0.0%	3.4%	5.5%	0.0%	0.0%	0.0%	0.0%	2.6%	3.3%	0.0%	0.0%	0.0%	0.0%	0.0%	8.1%	5.8%	2.3%	0.0%	0.0%	0.0%	0.0%	3.1%
Pedestrians	0	0	0	0	0	2	0	0	0	0	0	0	7	2	0	0	0	0	0	10	3	0	0	0	0	0	7	10	20
% Pedestrians	0.0%	0.0%	0.0%	0.0%	0.0%	100.0%	0.0%	0.0%	0.0%	0.0%	0.0%	0.0%	100.0%	100.0%	0.0%	0.0%	0.0%	0.0%	0.0%	80.8%	100.0%	0.0%	0.0%	0.0%	0.0%	0.0%	77.3%	100.0%	0.0%
Bicycles on Crosswalk	0	0	0	0	0	0	1	0	0	0	0	0	0	0	0	0	0	0	0	1	0	0	0	0	0	0	2	0	3
% Bicycles on Crosswalk	0.0%	0.0%	0.0%	0.0%	0.0%	0.0%	100.0%	0.0%	0.0%	0.0%	0.0%	0.0%	0.0%	0.0%	0.0%	0.0%	0.0%	0.0%	0.0%	0.1%	0.0%	0.0%	0.0%	0.0%	0.0%	0.0%	22.2%	0.0%	0.0%

Project : VBH Malta NY
 Site : Site 4
 Location : 42.948550, -73.790036
 Survey Date : 2021-04-28, Wednesday

Turning Movement Data Plot

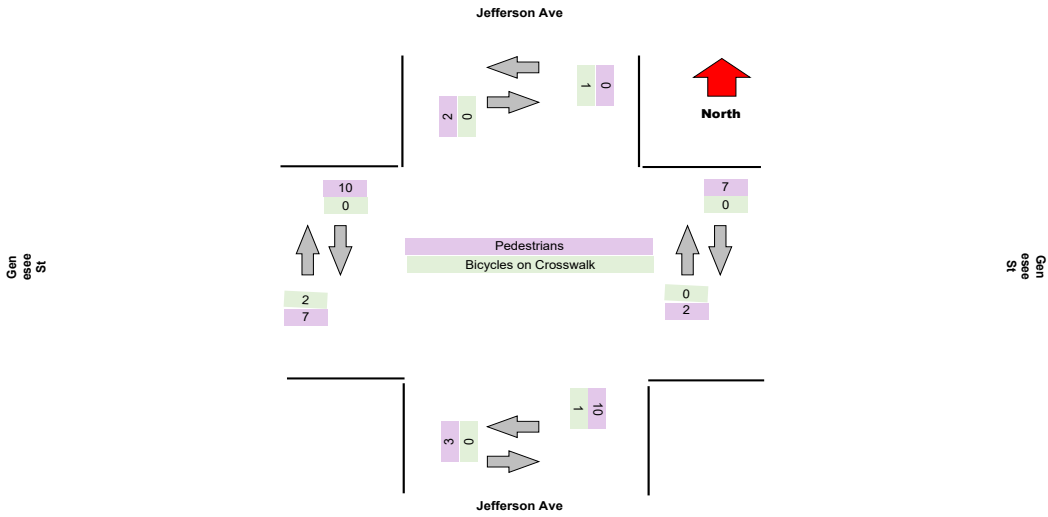
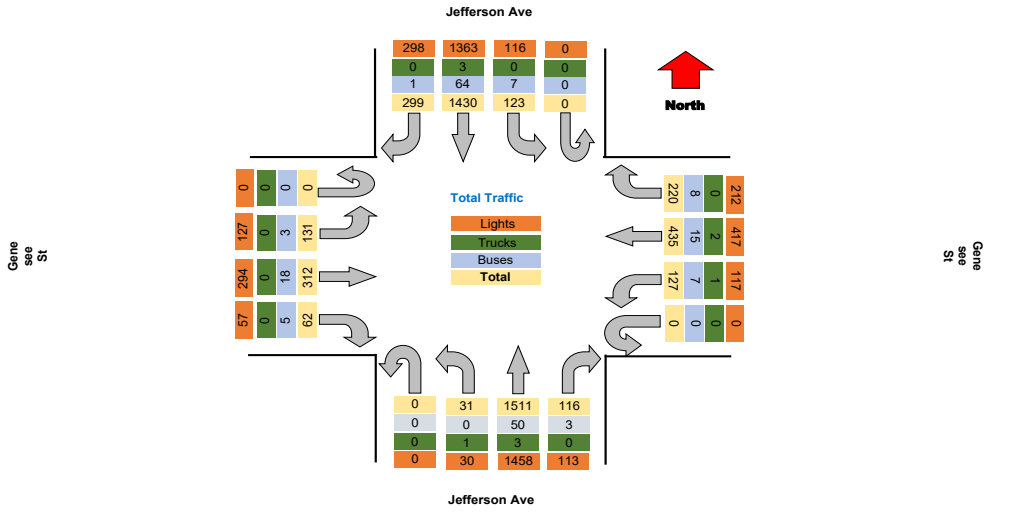

Turning Movement Peak Hour Data (AM)

7:30:00 AM

Leg Direction	Jefferson Ave					Genesee St					Jefferson Ave					Genesee St					Total									
	Right	Thru	Left	U-Turn	App Total	Peds CW	Peds CCW	Right	Thru	Left	U-Turn	App Total	Peds CW	Peds CCW	Right	Thru	Left	U-Turn	App Total	Peds CW		Peds CCW								
7:30:00 AM	11	75	7	0	93	0	0	18	28	4	0	50	0	0	3	94	3	0	100	0	2	0	10	8	0	18	0	1	261	
7:45:00 AM	12	96	6	0	114	0	0	22	45	11	0	78	0	1	7	117	0	0	125	0	0	2	16	10	0	28	0	0	345	
8:00:00 AM	21	111	3	0	135	0	1	16	40	6	0	65	0	0	8	84	4	0	96	0	0	4	26	8	0	40	0	0	336	
8:15:00 AM	65	94	9	0	119	0	0	10	37	10	0	57	0	0	4	83	0	0	87	0	0	3	19	5	0	27	0	0	290	
Grand Total	60	375	25	0	461	0	1	65	150	33	0	250	0	1	22	378	7	0	408	0	2	9	73	31	0	113	0	1	1232	
% Approach	13.0%	81.6%	5.4%	0.0%	0.0%	0.0%	0.0%	28.4%	60.0%	13.2%	0.0%	0.0%	0.0%	0.0%	5.4%	92.6%	1.7%	0.0%	0.0%	0.0%	0.0%	8.0%	64.6%	27.4%	0.0%	0.0%	0.0%	0.0%	0.0%	
% Total	4.9%	30.5%	2.0%	0.0%	37.4%	0.0%	0.0%	5.4%	12.2%	2.7%	0.0%	20.3%	0.0%	0.0%	1.8%	30.7%	0.6%	0.0%	33.1%	0.0%	0.0%	0.7%	5.9%	2.5%	0.0%	9.2%	0.0%	0.0%	0.0%	
PHF	0.714	0.847	0.694	0.000	0.854	0.000	0.000	0.750	0.833	0.750	0.000	0.801	0.000	0.000	0.688	0.808	0.438	0.000	0.816	0.000	0.000	0.563	0.652	0.775	0.000	0.706	0.000	0.000	0.893	
Lights	60	345	21	0	426	0	0	62	146	30	0	238	0	0	20	355	7	0	382	0	0	8	66	29	0	103	0	0	1149	
% Lights	100.0%	91.8%	84.0%	0.0%	92.4%	0.0%	0.0%	93.9%	97.3%	90.9%	0.0%	95.2%	0.0%	0.0%	90.9%	93.9%	100.0%	0.0%	93.6%	0.0%	0.0%	88.9%	90.4%	93.5%	0.0%	91.2%	0.0%	0.0%	93.3%	
Trucks	0	2	0	0	2	0	0	0	1	1	0	2	0	0	0	2	0	0	2	0	0	0	0	0	0	0	0	0	0	6
% Trucks	0.0%	0.5%	0.0%	0.0%	0.4%	0.0%	0.0%	0.0%	0.7%	3.0%	0.0%	0.8%	0.0%	0.0%	0.0%	0.5%	0.0%	0.0%	0.5%	0.0%	0.0%	0.0%	0.0%	0.0%	0.0%	0.0%	0.0%	0.0%	0.5%	
Buses	0	29	4	0	33	0	0	4	3	2	0	9	0	0	2	21	0	0	23	0	0	1	7	2	0	10	0	0	75	
% Buses	0.0%	7.7%	16.0%	0.0%	0.0%	0.0%	0.0%	6.1%	2.0%	6.1%	0.0%	0.0%	0.0%	0.0%	9.1%	5.6%	0.0%	0.0%	0.0%	0.0%	0.0%	11.1%	9.6%	6.5%	0.0%	0.0%	0.0%	6.1%		
Pedestrians	0	0	0	0	0	0	0	0	0	0	0	0	1	0	0	0	0	0	0	0	2	0	0	0	0	0	0	1	0	
% Pedestrians	0.0%	0.0%	0.0%	0.0%	0.0%	0.0%	0.0%	0.0%	0.0%	0.0%	0.0%	0.0%	100.0%	0.0%	0.0%	0.0%	0.0%	0.0%	0.0%	0.0%	100.0%	0.0%	0.0%	0.0%	0.0%	0.0%	0.0%	100.0%	0.0%	
Bicycles on Crosswalk	0	0	0	0	0	0	1	0	0	0	0	0	0	0	0	0	0	0	0	0	0	0	0	0	0	0	0	0	0	
% Bicycles on Crosswalk	0.0%	0.0%	0.0%	0.0%	0.0%	0.0%	100.0%	0.0%	0.0%	0.0%	0.0%	0.0%	0.0%	0.0%	0.0%	0.0%	0.0%	0.0%	0.0%	0.0%	0.0%	0.0%	0.0%	0.0%	0.0%	0.0%	0.0%	0.0%	0.0%	

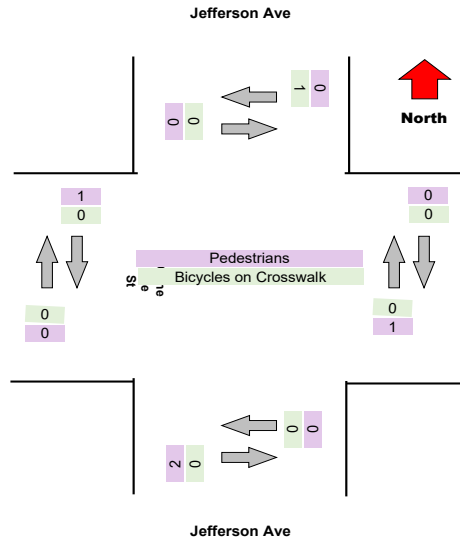
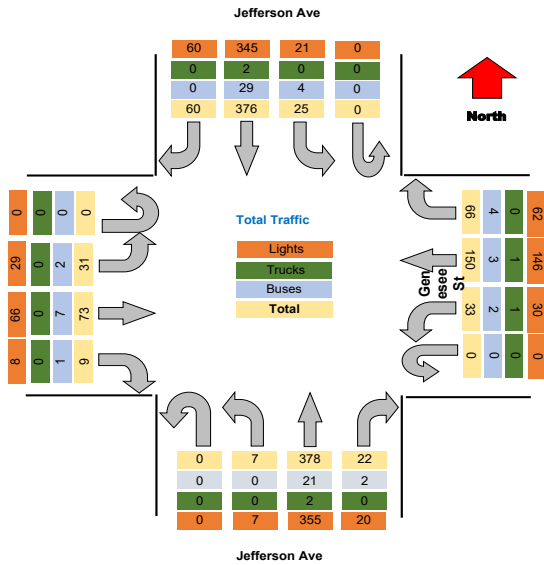

Turning Movement Peak Hour Data (PM)

4:15:00 PM

Leg Direction	Jefferson Ave										Genesee St										Total									
	Southbound					Westbound					Northbound					Eastbound														
	Right	Thru	Left	U-Turn	App Total	Peds CW	Peds CCW	Right	Thru	Left	U-Turn	App Total	Peds CW	Peds CCW	Right	Thru	Left	U-Turn	App Total	Peds CW		Peds CCW								
4:15:00 PM	23	125	14	0	162	0	0	16	40	8	0	64	0	0	6	135	3	0	144	2	0	11	26	11	0	48	3	4	418	
4:30:00 PM	24	124	12	0	160	1	0	24	29	18	0	71	0	0	8	109	1	0	118	0	0	8	29	8	0	45	0	0	394	
4:45:00 PM	26	103	9	0	138	0	0	17	24	11	0	52	0	0	15	108	3	0	126	1	0	3	30	8	0	41	1	0	357	
5:00:00 PM	30	116	9	0	149	0	0	11	25	9	0	45	1	0	13	133	3	0	149	0	0	6	25	9	0	40	1	0	383	
Grand Total	103	462	44	0	609	1	0	68	118	46	0	232	1	0	42	495	10	0	537	3	0	29	110	36	0	174	5	4	1522	
% Approach	16.9%	75.9%	7.2%	0.0%	0.0%	0.0%	0.0%	29.3%	50.9%	19.8%	0.0%	0.0%	0.0%	0.0%	7.8%	90.3%	1.9%	0.0%	0.0%	0.0%	0.0%	16.1%	63.2%	20.7%	0.0%	0.0%	0.0%	0.0%	0.0%	
% Total	6.6%	29.8%	2.8%	0.0%	38.2%	0.0%	0.0%	4.4%	7.6%	3.0%	0.0%	14.9%	0.0%	0.0%	2.7%	31.3%	0.6%	0.0%	34.6%	0.0%	0.0%	1.8%	7.1%	2.3%	0.0%	11.2%	0.0%	0.0%	0.0%	
PHF	0.858	0.924	0.786	0.000	0.940	0.000	0.000	0.708	0.738	0.639	0.000	0.817	0.000	0.000	0.700	0.898	0.833	0.000	0.801	0.000	0.000	0.636	0.917	0.818	0.000	0.906	0.000	0.000	0.928	
Lights	103	445	43	0	591	0	0	66	110	41	0	217	0	0	42	474	9	0	525	0	0	25	106	36	0	167	0	0	1500	
% Lights	100.0%	96.3%	97.7%	0.0%	97.0%	0.0%	0.0%	97.1%	93.2%	89.1%	0.0%	93.5%	0.0%	0.0%	100.0%	97.7%	90.0%	0.0%	97.8%	0.0%	0.0%	89.3%	96.4%	100.0%	0.0%	96.0%	0.0%	0.0%	96.6%	
Trucks	0	0	0	0	0	0	0	0	1	0	0	1	0	0	0	0	1	0	1	0	0	0	0	0	0	0	0	0	2	
% Trucks	0.0%	0.0%	0.0%	0.0%	0.0%	0.0%	0.0%	0.0%	0.8%	0.0%	0.0%	0.4%	0.0%	0.0%	0.0%	0.0%	10.0%	0.0%	0.2%	0.0%	0.0%	0.0%	0.0%	0.0%	0.0%	0.0%	0.0%	0.0%	0.1%	
Buses	0	17	1	0	18	0	0	2	6	3	0	11	0	0	0	11	0	0	11	0	0	3	4	0	0	7	0	0	47	
% Buses	0.0%	3.7%	2.3%	0.0%	0.0%	0.0%	0.0%	2.9%	5.1%	6.5%	0.0%	0.0%	0.0%	0.0%	0.0%	2.3%	0.0%	0.0%	0.0%	0.0%	0.0%	10.7%	3.8%	0.0%	0.0%	0.0%	0.0%	0.0%	3.0%	
Pedestrians	0	0	0	0	0	1	0	0	0	0	0	0	1	0	0	0	0	0	0	0	2	0	0	0	0	0	3	4	0	
% Pedestrians	0.0%	0.0%	0.0%	0.0%	0.0%	100.0%	0.0%	0.0%	0.0%	0.0%	0.0%	0.0%	100.0%	0.0%	0.0%	0.0%	0.0%	0.0%	0.0%	0.0%	66.7%	0.0%	0.0%	0.0%	0.0%	0.0%	0.0%	100.0%	0.0%	
Bicycles on Crosswalk	0	0	0	0	0	0	0	0	0	0	0	0	0	0	0	0	0	0	0	1	0	0	0	0	0	0	0	2	0	
% Bicycles on Crosswalk	0.0%	0.0%	0.0%	0.0%	0.0%	0.0%	0.0%	0.0%	0.0%	0.0%	0.0%	0.0%	0.0%	0.0%	0.0%	0.0%	0.0%	0.0%	0.0%	33.3%	0.0%	0.0%	0.0%	0.0%	0.0%	0.0%	0.0%	40.0%	0.0%	0.0%

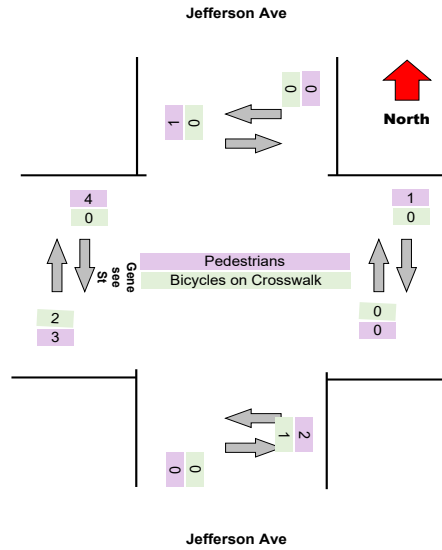
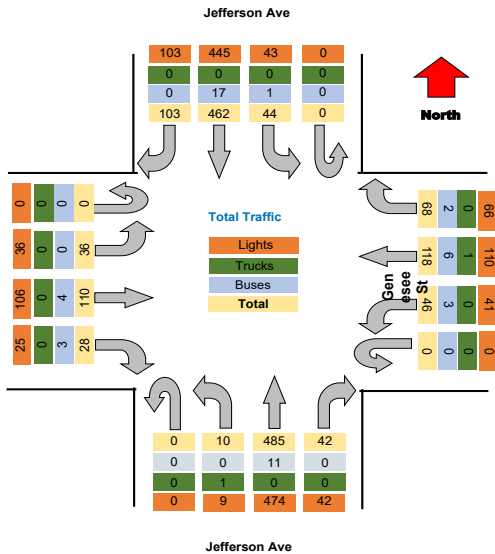

Project : VBH Malta NY
Site : Site 4
Location : 42.948550, -73.790036

TSTData.com

Survey Date : 2021-04-28, Wednesday

Project	LaBella
Project Code	LaBella
Site Name	12
Legs and Movements	All Processed Legs & Move
Bin Size	15 minutes
Survey Date	2021-11-04, Thursday
Location	12
Latitude and Longitude	42.896155, -78.853968

	Start	End	PHF
Forced Peak AM	2021/11/04 07:30:00	2021/11/04 08:30:00	0.92
Forced Peak PM	2021/11/04 16:30:00	2021/11/04 17:30:00	0.96
AM Peak	2021/11/04 07:30:00	2021/11/04 08:30:00	0.92
PM Peak	2021/11/04 16:15:00	2021/11/04 17:15:00	0.92

Turning Movement Data

Leg Direction	Jefferson Ave							Genesee St							Jefferson Ave							Genesee St							Total
	Southbound							Westbound							Northbound							Eastbound							
	Right	Thru	Left	U-Turn	App Total	Peds CV	Peds CCV	Right	Thru	Left	U-Turn	App Total	Peds CV	Peds CCV	Right	Thru	Left	U-Turn	App Total	Peds CV	Peds CCV	Right	Thru	Left	U-Turn	App Total	Peds CV	Peds CCV	
Start Time																													
6:30:00 AM	9	33	3	0	45	0	0	4	10	4	0	18	0	0	2	47	0	0	49	0	0	1	6	9	0	16	1	1	128
6:45:00 AM	6	43	6	0	55	0	0	12	21	6	0	39	0	0	4	49	0	0	53	0	0	0	6	9	0	15	0	0	162
Hourly Total	15	76	9	0	100	0	0	16	31	10	0	57	0	0	6	96	0	0	102	0	0	1	12	18	0	31	1	1	230
7:00:00 AM	6	37	3	0	46	0	0	8	17	0	0	25	0	0	4	57	1	0	62	0	0	1	8	6	0	15	0	0	146
7:15:00 AM	9	54	3	0	66	0	0	10	24	2	0	36	0	0	4	66	1	0	71	0	0	1	13	3	0	17	0	0	190
7:30:00 AM	10	80	6	0	96	0	0	18	35	8	0	61	0	0	2	92	1	0	95	0	1	2	15	7	0	24	2	2	276
7:45:00 AM	8	84	7	0	99	0	1	22	38	11	0	72	0	0	8	111	2	0	121	0	0	2	10	4	0	16	0	0	308
Hourly Total	33	255	19	0	307	0	1	56	114	21	0	192	0	0	18	326	5	0	349	0	1	6	46	20	0	72	2	3	920
8:00:00 AM	20	92	3	0	115	0	0	17	33	5	0	55	1	0	8	110	0	0	119	0	0	4	27	7	0	38	0	0	327
8:15:00 AM	17	98	8	0	123	0	0	12	29	5	0	46	1	0	6	83	4	0	94	0	0	1	22	3	0	26	1	0	289
Hourly Total	37	190	11	0	238	0	0	29	62	10	0	101	2	0	14	193	4	0	213	0	0	5	49	10	0	64	1	0	616
4:00:00 PM	24	131	17	0	172	0	0	7	31	16	0	54	0	0	11	86	2	0	99	0	1	11	39	13	0	63	0	0	388
4:15:00 PM	33	134	12	0	179	0	0	18	39	15	0	72	0	2	10	110	4	0	124	0	2	5	25	12	0	42	0	0	417
4:30:00 PM	21	107	11	0	139	0	0	12	25	7	0	44	2	0	9	137	5	0	151	1	0	10	35	5	0	50	0	0	384
4:45:00 PM	23	102	11	0	136	0	0	11	32	16	0	59	2	2	11	117	2	0	130	0	0	1	32	8	0	41	1	1	366
Hourly Total	101	474	51	0	626	0	0	48	127	54	0	229	4	4	41	450	13	0	504	1	3	27	131	38	0	196	1	1	1555
5:00:00 PM	32	97	3	0	132	0	0	18	19	22	0	59	0	1	12	113	3	0	128	0	0	6	36	10	0	54	0	1	373
5:15:00 PM	28	104	10	0	142	0	0	13	25	12	0	50	0	0	8	100	2	0	110	0	0	3	31	10	0	44	0	0	346
5:30:00 PM	15	96	9	0	120	1	2	13	20	10	0	43	0	1	17	111	9	0	137	0	1	2	26	5	0	33	0	4	333
5:45:00 PM	18	110	5	0	133	0	0	18	31	12	0	61	1	0	5	89	5	0	99	0	2	8	18	8	0	34	0	3	327
Hourly Total	83	407	27	0	527	1	2	62	95	56	0	213	1	2	42	413	19	0	474	0	3	21	111	33	0	165	0	8	1379
Grand Total	279	1402	117	0	1798	1	3	211	429	151	0	792	7	6	121	1478	41	0	1642	1	7	60	349	119	0	528	5	13	4780
% Approach	15.5%	78.0%	6.5%	0.0%	0.0%	0.0%	0.0%	26.6%	54.2%	19.1%	0.0%	0.0%	0.0%	0.0%	7.4%	90.0%	2.5%	0.0%	0.0%	0.0%	0.0%	11.4%	66.1%	22.5%	0.0%	0.0%	0.0%	0.0%	0.0%
% Total	5.9%	29.5%	2.5%	0.0%	37.8%	0.0%	0.0%	4.4%	9.0%	3.2%	0.0%	16.6%	0.0%	0.0%	2.5%	31.1%	0.9%	0.0%	34.5%	0.0%	0.0%	1.3%	7.3%	2.5%	0.0%	11.1%	0.0%	0.0%	0.0%
Lights	277	1336	112	0	1725	0	0	205	414	139	0	758	0	0	117	1429	40	0	1586	0	0	58	325	113	0	496	0	0	4565
% Lights	99.3%	95.3%	95.7%	0.0%	95.9%	0.0%	0.0%	97.2%	96.9%	92.1%	0.0%	95.7%	0.0%	0.0%	96.7%	96.7%	97.8%	0.0%	96.6%	0.0%	0.0%	96.7%	93.1%	95.0%	0.0%	93.9%	0.0%	0.0%	95.9%
Trucks	0	0	0	0	0	0	0	1	0	11	0	2	0	0	1	4	0	0	5	0	0	0	3	0	0	3	0	0	10
% Trucks	0.0%	0.0%	0.0%	0.0%	0.0%	0.0%	0.0%	0.5%	0.0%	0.7%	0.0%	0.3%	0.0%	0.0%	0.8%	0.3%	0.0%	0.0%	0.3%	0.0%	0.0%	0.0%	0.9%	0.0%	0.0%	0.6%	0.0%	0.0%	0.2%
Buses	2	64	5	0	71	0	0	5	15	11	0	31	0	0	3	44	1	0	48	0	0	2	20	6	0	28	0	0	178
% Buses	0.7%	4.6%	4.3%	0.0%	0.0%	0.0%	0.0%	0.0%	3.5%	7.3%	0.0%	0.0%	0.0%	0.0%	2.5%	3.0%	2.4%	0.0%	0.0%	0.0%	0.0%	3.3%	5.7%	5.0%	0.0%	0.0%	0.0%	0.0%	3.7%
Pedestrians	0	0	0	0	0	1	2	0	0	0	0	0	7	6	0	0	0	0	0	1	7	0	0	0	0	0	5	12	0
% Pedestrians	0.0%	0.0%	0.0%	0.0%	0.0%	100.0%	66.7%	0.0%	0.0%	0.0%	0.0%	0.0%	100.0%	100.0%	0.0%	0.0%	0.0%	0.0%	0.0%	100.0%	100.0%	0.0%	0.0%	0.0%	0.0%	0.0%	100.0%	62.3%	0.0%
Bicycles on Crosswalk	0	0	0	0	0	0	1	0	0	0	0	0	0	0	0	0	0	0	0	0	0	0	0	0	0	0	0	1	0
% Bicycles on Crosswalk	0.0%	0.0%	0.0%	0.0%	0.0%	0.0%	33.3%	0.0%	0.0%	0.0%	0.0%	0.0%	0.0%	0.0%	0.0%	0.0%	0.0%	0.0%	0.0%	0.0%	0.0%	0.0%	0.0%	0.0%	0.0%	0.0%	0.0%	7.7%	0.0%

Project : VBH Malta NY
 Site : Site 4
 Location : 42.948550, -73.790036
 Survey Date : 2021-04-28, Wednesday

Turning Movement Data Plot

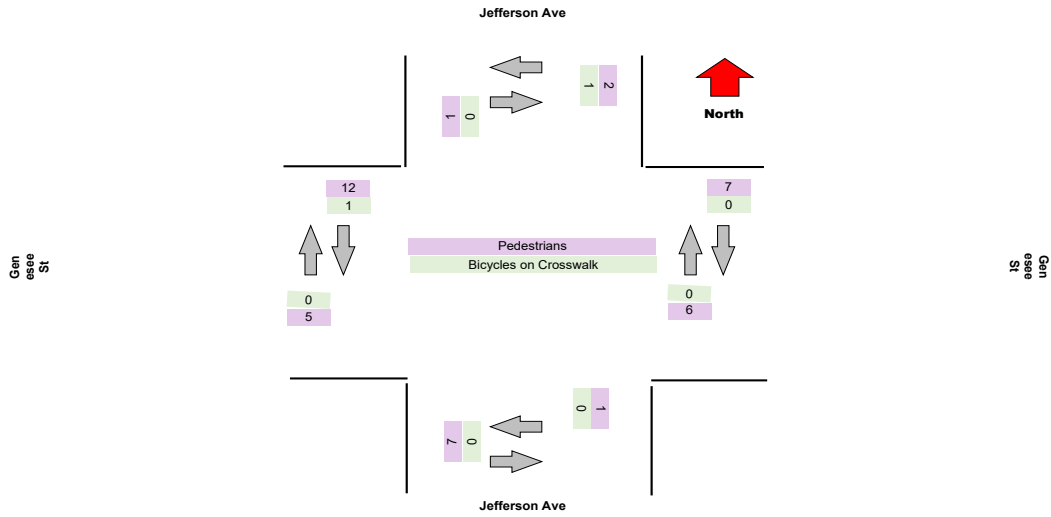
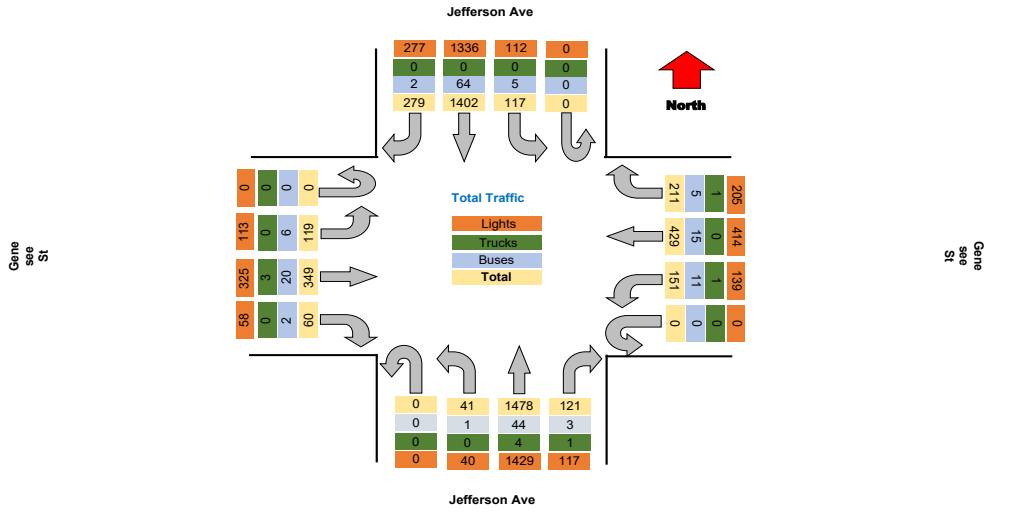

Turning Movement Peak Hour Data (AM)

7:30:00 AM

Leg Direction	Jefferson Ave				Genesee St				Jefferson Ave				Genesee St				Total				
	Southbound		Northbound		Westbound		Eastbound		Northbound		Southbound		Eastbound								
Start Time	Right	Thru	Left	U-Turn	App Total	Peds CW	Peds CCW	Right	Thru	Left	U-Turn	App Total	Peds CW	Peds CCW	Right	Thru	Left	U-Turn	App Total	Peds CW	Peds CCW
7:30:00 AM	10	80	6	0	96	0	0	18	35	8	0	61	0	0	2	92	1	0	95	0	1
7:45:00 AM	8	84	7	0	99	0	1	22	38	11	0	72	0	0	8	111	2	0	121	0	0
8:00:00 AM	20	92	3	0	115	0	0	17	33	5	0	55	1	0	8	110	0	0	119	0	0
8:15:00 AM	17	98	8	0	123	0	0	12	29	5	0	46	1	0	6	83	4	0	94	0	0
Grand Total	55	354	24	0	433	0	1	69	135	29	0	234	2	0	24	395	7	0	429	0	2
% Approach	12.7%	81.8%	5.5%	0.0%	0.0%	0.0%	0.0%	29.5%	57.7%	12.4%	0.0%	0.0%	0.0%	0.0%	5.6%	92.3%	1.6%	0.0%	0.0%	0.0%	0.0%
% Total	4.6%	29.5%	2.0%	0.0%	36.1%	0.0%	0.0%	5.8%	11.3%	2.4%	0.0%	19.5%	0.0%	0.0%	2.0%	33.0%	0.6%	0.0%	35.8%	0.0%	0.0%
PHF	0.688	0.903	0.750	0.000	0.890	0.000	0.000	0.784	0.888	0.659	0.000	0.813	0.000	0.000	0.750	0.892	0.438	0.000	0.886	0.000	0.000
Lights	55	328	20	0	403	0	0	66	133	25	0	224	0	0	22	374	7	0	403	0	0
% Lights	100.0%	92.7%	83.3%	0.0%	93.1%	0.0%	0.0%	95.7%	98.5%	86.2%	0.0%	95.7%	0.0%	0.0%	91.7%	94.4%	100.0%	0.0%	93.9%	0.0%	0.0%
Trucks	0	0	0	0	0	0	0	1	0	1	0	2	0	0	1	2	0	0	3	0	0
% Trucks	0.0%	0.0%	0.0%	0.0%	0.0%	0.0%	0.0%	1.4%	0.0%	3.4%	0.0%	0.9%	0.0%	0.0%	4.2%	0.5%	0.0%	0.0%	0.7%	0.0%	0.0%
Buses	0	26	4	0	30	0	0	2	2	3	0	7	0	0	1	20	0	0	21	0	0
% Buses	0.0%	7.3%	16.7%	0.0%	0.0%	0.0%	0.0%	2.9%	1.5%	10.3%	0.0%	0.0%	0.0%	0.0%	4.2%	5.1%	0.0%	0.0%	0.0%	0.0%	0.0%
Pedestrians	0	0	0	0	0	0	0	0	0	0	0	2	0	0	0	0	0	0	0	0	0
% Pedestrians	0.0%	0.0%	0.0%	0.0%	0.0%	0.0%	0.0%	0.0%	0.0%	0.0%	0.0%	0.8%	0.0%	100.0%	0.0%	0.0%	0.0%	0.0%	0.0%	0.0%	0.0%
Bicycles on Crosswalk	0	0	0	0	0	1	0	0	0	0	0	0	0	0	0	0	0	0	0	0	0
% Bicycles on Crosswalk	0.0%	0.0%	0.0%	0.0%	0.0%	100.0%	0.0%	0.0%	0.0%	0.0%	0.0%	0.0%	0.0%	0.0%	0.0%	0.0%	0.0%	0.0%	0.0%	0.0%	0.0%

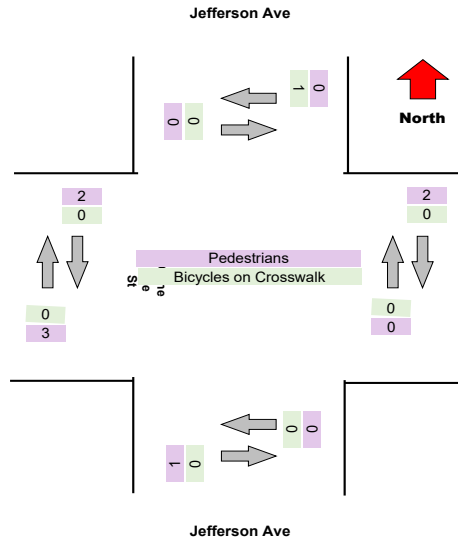
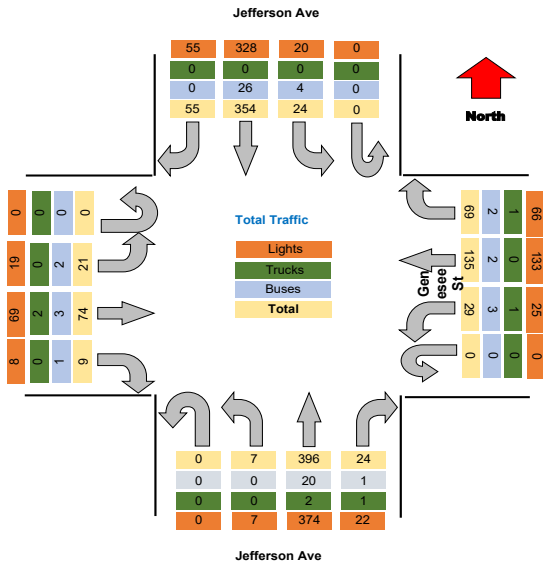

Turning Movement Peak Hour Data (PM)

4:15:00 PM

Leg Direction	Jefferson Ave				Genesee St				Jefferson Ave				Genesee St				Total				
	Southbound		Northbound		Westbound		Eastbound		Northbound		Southbound		Westbound		Eastbound						
Start Time	Right	Thru	Left	U-Turn	App Total	Peds CW	Peds CCW	Right	Thru	Left	U-Turn	App Total	Peds CW	Peds CCW	Right	Thru	Left	U-Turn	App Total	Peds CW	Peds CCW
4:15:00 PM	33	134	12	0	179	0	0	18	39	15	0	72	0	2	10	110	4	0	124	0	2
4:30:00 PM	21	107	11	0	139	0	0	12	25	7	0	44	2	2	9	137	5	0	151	1	0
4:45:00 PM	23	102	11	0	136	0	0	11	32	16	0	59	2	2	11	117	2	0	130	0	0
5:00:00 PM	32	97	3	0	132	0	0	18	19	22	0	59	0	0	12	113	3	0	128	0	0
Grand Total	109	440	37	0	586	0	0	59	115	60	0	234	2	4	42	477	14	0	533	1	2
% Approach	18.6%	75.1%	6.3%	0.0%	0.0%	0.0%	0.0%	25.2%	49.1%	25.6%	0.0%	0.0%	0.0%	0.0%	7.9%	89.5%	2.6%	0.0%	0.0%	0.0%	0.0%
% Total	7.1%	28.6%	2.4%	0.0%	38.1%	0.0%	0.0%	3.8%	7.5%	3.9%	0.0%	15.2%	0.0%	0.0%	2.7%	31.0%	0.9%	0.0%	34.6%	0.0%	0.0%
PHF	0.826	0.821	0.771	0.000	0.818	0.000	0.000	0.819	0.737	0.682	0.000	0.813	0.000	0.000	0.875	0.870	0.700	0.000	0.882	0.000	0.000
Lights	108	421	37	0	566	0	0	58	109	55	0	222	0	0	42	465	14	0	521	0	0
% Lights	99.1%	95.7%	100.0%	0.0%	96.6%	0.0%	0.0%	98.3%	94.8%	91.7%	0.0%	94.9%	0.0%	0.0%	100.0%	97.6%	100.0%	0.0%	97.7%	0.0%	0.0%
Trucks	0	0	0	0	0	0	0	0	0	0	0	0	0	0	0	1	0	0	1	0	0
% Trucks	0.0%	0.0%	0.0%	0.0%	0.0%	0.0%	0.0%	0.0%	0.0%	0.0%	0.0%	0.0%	0.0%	0.0%	0.0%	0.2%	0.0%	0.0%	0.2%	0.0%	0.0%
Buses	1	19	0	0	20	0	0	1	6	5	0	12	0	0	0	10	0	0	10	0	0
% Buses	0.9%	4.3%	0.0%	0.0%	0.0%	0.0%	0.0%	1.7%	5.2%	8.3%	0.0%	0.0%	0.0%	0.0%	0.0%	2.1%	0.0%	0.0%	0.0%	0.0%	0.0%
Pedestrians	0	0	0	0	0	0	0	0	0	0	0	4	5	0	0	0	0	0	1	2	0
% Pedestrians	0.0%	0.0%	0.0%	0.0%	0.0%	0.0%	0.0%	0.0%	0.0%	0.0%	0.0%	0.0%	100.0%	100.0%	0.0%	0.0%	0.0%	0.0%	0.6%	100.0%	100.0%
Bicycles on Crosswalk	0	0	0	0	0	0	0	0	0	0	0	0	0	0	0	0	0	0	0	0	0
% Bicycles on Crosswalk	0.0%	0.0%	0.0%	0.0%	0.0%	0.0%	0.0%	0.0%	0.0%	0.0%	0.0%	0.0%	0.0%	0.0%	0.0%	0.0%	0.0%	0.0%	0.0%	0.0%	0.0%

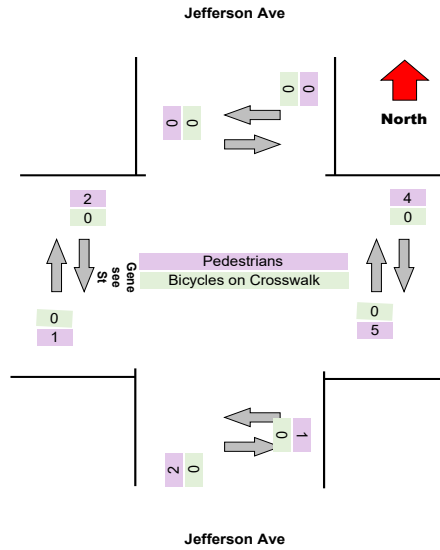
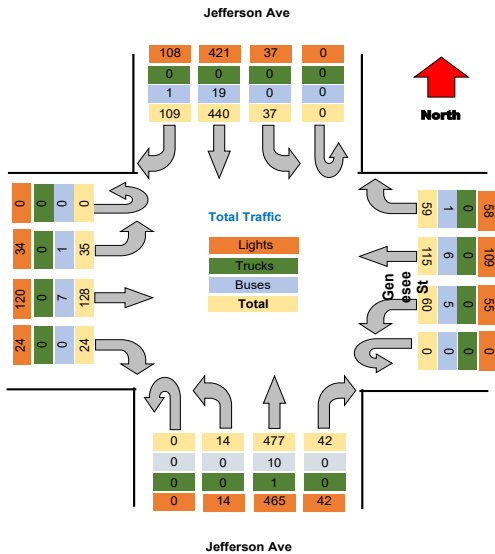

Project : VBH Malta NY
 Site : Site 4
 Location : 42.948550, -73.790036
 Survey Date : 2021-04-28, Wednesday

Turning Movement Data Plot

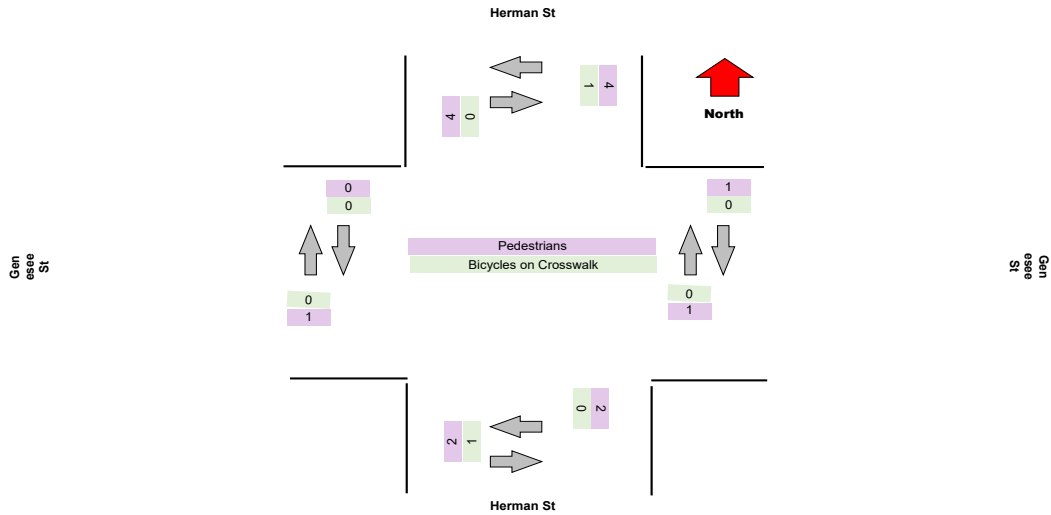
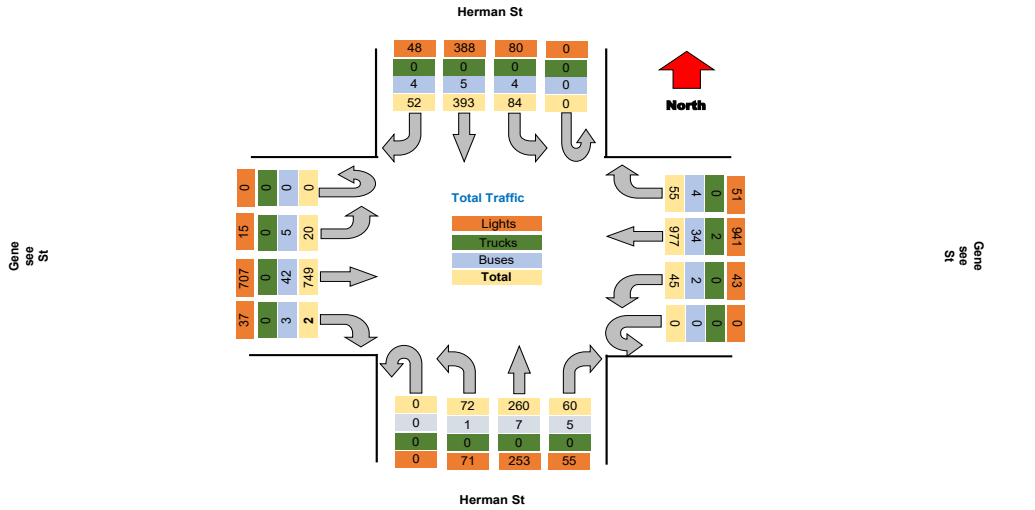

Project : VBH Malta NY
Site : Site 4
Location : 42.948550, -73.790036

TSTData.com

Survey Date : 2021-04-28, Wednesday

Turning Movement Peak Hour Data (AM)

7:30:00 AM

Leg Direction	Herman St Southbound					Genesee St Westbound					Herman St Northbound					Genesee St Eastbound					Total						
	Right	Thru	Left	U-Turn	App Total	Peds CW	Peds CCW	Right	Thru	Left	U-Turn	App Total	Peds CW	Peds CCW	Right	Thru	Left	U-Turn	App Total	Peds CW		Peds CCW					
7:30:00 AM	2	16	3	0	21	1	0	2	73	1	0	76	0	0	2	12	1	0	15	0	0	19	0	0	131		
7:45:00 AM	5	24	3	0	32	0	0	3	100	4	0	107	0	0	3	19	7	0	29	0	0	2	37	0	0	207	
8:00:00 AM	11	21	5	0	37	0	0	4	96	5	0	105	0	0	0	14	4	0	18	0	0	3	55	2	0	60	
8:15:00 AM	3	21	6	0	30	1	0	3	75	1	0	79	0	0	1	10	2	0	13	0	0	0	32	0	0	154	
Grand Total	21	82	17	0	120	2	0	12	344	11	0	357	0	0	6	55	14	0	75	0	0	5	142	3	0	712	
% Approach	17.5%	68.3%	14.2%	0.0%	0.0%	0.0%	0.0%	14.2%	85.8%	0.0%	0.0%	0.0%	0.0%	0.0%	45.1%	41.7%	13.2%	0.0%	0.0%	0.0%	0.0%	0.0%	66.2%	33.8%	0.0%	0.0%	0.0%
% Total	2.9%	11.5%	2.4%	0.0%	16.8%	0.0%	0.0%	1.7%	48.3%	1.5%	0.0%	51.5%	0.0%	0.0%	0.8%	7.7%	2.0%	0.0%	10.5%	0.0%	0.0%	0.7%	19.9%	0.4%	0.0%	21.1%	
PHF	0.477	0.854	0.708	0.000	0.811	0.000	0.000	0.750	0.880	0.550	0.000	0.857	0.000	0.000	0.500	0.724	0.500	0.000	0.647	0.000	0.000	0.417	0.645	0.375	0.000	0.625	
Lights	20	81	17	0	118	0	0	11	331	11	0	353	0	0	4	51	14	0	69	0	0	5	127	2	0	134	
% Lights	95.2%	98.8%	100.0%	0.0%	98.3%	0.0%	0.0%	91.7%	96.2%	100.0%	0.0%	96.2%	0.0%	0.0%	66.7%	92.7%	100.0%	0.0%	92.0%	0.0%	0.0%	100.0%	89.4%	66.7%	0.0%	89.3%	
Trucks	0	0	0	0	0	0	0	0	1	0	0	1	0	0	0	0	0	0	0	0	0	0	0	0	0	0	1
% Trucks	0.0%	0.0%	0.0%	0.0%	0.0%	0.0%	0.0%	0.0%	0.3%	0.0%	0.0%	0.3%	0.0%	0.0%	0.0%	0.0%	0.0%	0.0%	0.0%	0.0%	0.0%	0.0%	0.0%	0.0%	0.0%	0.0%	0.1%
Buses	1	1	0	0	2	0	0	1	12	0	0	13	0	0	2	4	0	0	6	0	0	0	15	1	0	16	
% Buses	4.8%	1.2%	0.0%	0.0%	0.0%	0.0%	0.0%	8.3%	3.5%	0.0%	0.0%	0.0%	0.0%	0.0%	33.3%	7.3%	0.0%	0.0%	0.0%	0.0%	0.0%	0.0%	10.6%	33.3%	0.0%	0.0%	
Pedestrians	0	0	0	0	0	2	0	0	0	0	0	0	0	0	0	0	0	0	0	0	0	0	0	0	0	0	
% Pedestrians	0.0%	0.0%	0.0%	0.0%	0.0%	100.0%	0.0%	0.0%	0.0%	0.0%	0.0%	0.0%	0.0%	0.0%	0.0%	0.0%	0.0%	0.0%	0.0%	0.0%	0.0%	0.0%	0.0%	0.0%	0.0%	0.0%	
Bicycles on Crosswalk	0	0	0	0	0	0	0	0	0	0	0	0	0	0	0	0	0	0	0	0	0	0	0	0	0	0	
% Bicycles on Crosswalk	0.0%	0.0%	0.0%	0.0%	0.0%	0.0%	0.0%	0.0%	0.0%	0.0%	0.0%	0.0%	0.0%	0.0%	0.0%	0.0%	0.0%	0.0%	0.0%	0.0%	0.0%	0.0%	0.0%	0.0%	0.0%	0.0%	

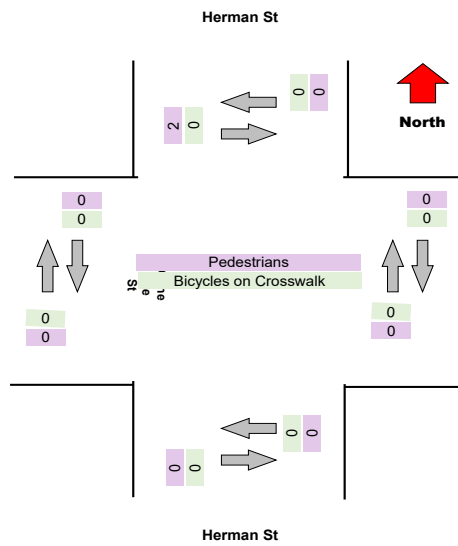
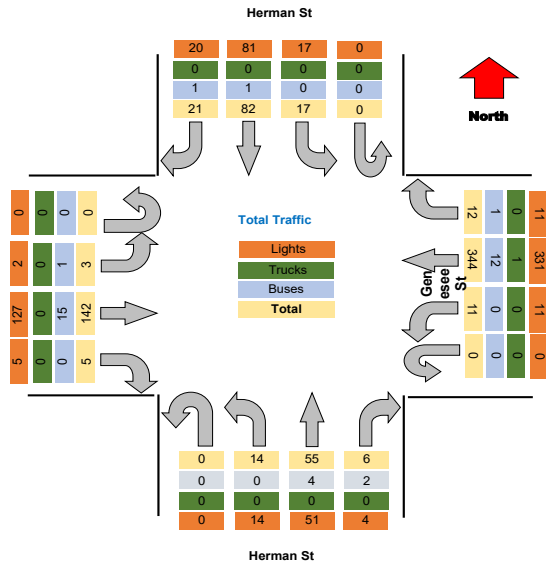

Turning Movement Peak Hour Data (PM)

4:30:00 PM

Leg Direction	Herman St										Genesee St										Herman St										Genesee St										Total
	Southbound					Westbound					Northbound					Eastbound																									
	Right	Thru	Left	U-Turn	App Total	Right	Thru	Left	U-Turn	App Total	Right	Thru	Left	U-Turn	App Total	Right	Thru	Left	U-Turn	App Total																					
4:30:00 PM	5	39	9	0	53	1	57	2	0	60	11	19	7	0	37	7	97	2	0	106	0	0	0	0	0	256															
4:45:00 PM	4	33	3	0	40	5	58	4	0	67	6	23	8	0	37	3	78	1	0	82	0	0	0	0	0	224															
5:00:00 PM	3	35	7	0	45	3	60	4	0	67	9	17	9	0	35	4	72	1	0	77	0	0	0	0	0	196															
5:15:00 PM	3	29	5	0	37	6	47	5	0	58	6	20	5	0	31	5	62	3	0	70	0	0	0	0	0	902															
Grand Total	15	136	24	0	175	15	222	15	0	252	32	79	29	0	140	19	309	7	0	335	0	0	0	0	0	902															
% Approach	8.6%	77.7%	13.7%	0.0%	0.0%	14.2%	85.8%	0.0%	0.0%	0.0%	45.1%	41.7%	13.2%	0.0%	0.0%	0.0%	66.2%	33.8%	0.0%	0.0%	0.0%	0.0%	0.0%	0.0%	0.0%	0.0%															
% Total	1.7%	15.1%	2.7%	0.0%	19.4%	1.7%	24.6%	1.7%	0.0%	27.9%	3.5%	8.8%	3.2%	0.0%	15.5%	2.1%	34.3%	0.8%	0.0%	37.1%	0.0%	0.0%	0.0%	0.0%	0.0%	0.881															
PHF	0.750	0.872	0.667	0.000	0.825	0.625	0.925	0.750	0.000	0.940	0.727	0.859	0.806	0.000	0.846	0.679	0.796	0.583	0.000	0.790	0.000	0.000	0.000	0.000	0.000	0.881															
Lights	15	133	23	0	171	15	213	14	0	242	29	79	29	0	137	17	300	6	0	323	0	0	0	0	0	873															
% Lights	100.0%	97.8%	95.8%	0.0%	97.7%	100.0%	95.9%	93.3%	0.0%	96.0%	90.6%	100.0%	100.0%	0.0%	97.9%	89.5%	97.1%	85.7%	0.0%	96.4%	0.0%	0.0%	0.0%	0.0%	0.0%	96.8%															
Trucks	0	0	0	0	0	0	0	0	0	0	0	0	0	0	0	0	0	0	0	0	0	0	0	0	0	0															
% Trucks	0.0%	0.0%	0.0%	0.0%	0.0%	0.0%	0.0%	0.0%	0.0%	0.0%	0.0%	0.0%	0.0%	0.0%	0.0%	0.0%	0.0%	0.0%	0.0%	0.0%	0.0%	0.0%	0.0%	0.0%	0.0%	0.0%															
Buses	0	3	1	0	4	0	9	1	0	10	3	0	0	0	3	2	9	1	0	12	0	0	0	0	0	29															
% Buses	0.0%	2.2%	4.2%	0.0%	0.0%	0.0%	4.1%	6.7%	0.0%	0.0%	9.4%	0.0%	0.0%	0.0%	0.0%	10.5%	2.9%	14.3%	0.0%	0.0%	0.0%	0.0%	0.0%	0.0%	0.0%	3.2%															
Pedestrians	0	0	0	0	0	2	3	0	0	5	0	0	0	0	0	0	0	0	0	0	0	0	0	0	0	0															
% Pedestrians	0.0%	0.0%	0.0%	0.0%	0.0%	100.0%	75.0%	0.0%	0.0%	0.0%	0.0%	0.0%	0.0%	0.0%	0.0%	0.0%	0.0%	0.0%	0.0%	0.0%	0.0%	0.0%	0.0%	0.0%	0.0%	0.0%															
Bicycles on Crosswalk	0	0	0	0	0	0	0	0	0	0	0	0	0	0	0	0	0	0	0	0	0	0	0	0	0	0															
% Bicycles on Crosswalk	0.0%	0.0%	0.0%	0.0%	0.0%	0.0%	0.0%	0.0%	0.0%	0.0%	0.0%	0.0%	0.0%	0.0%	0.0%	0.0%	0.0%	0.0%	0.0%	0.0%	0.0%	0.0%	0.0%	0.0%	0.0%	0.0%															

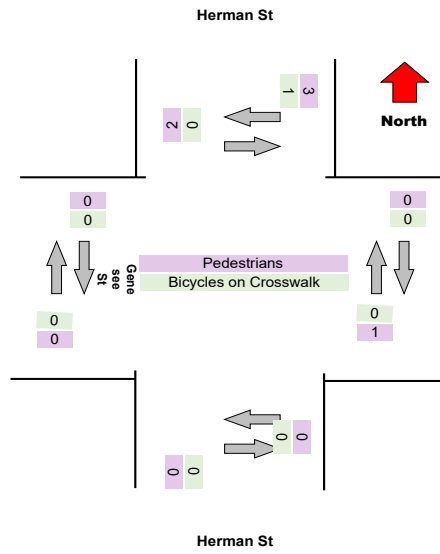
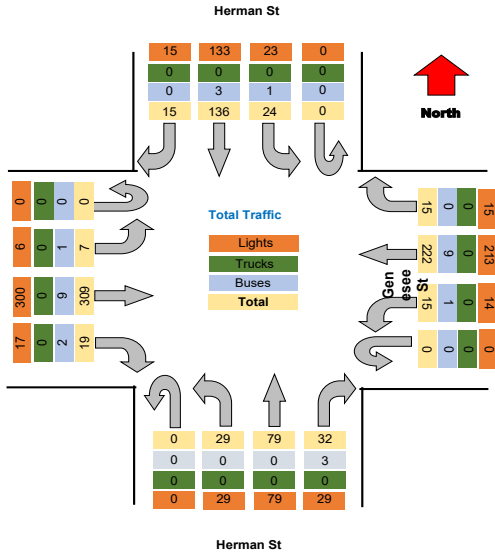

Project : VBH Malta NY
 Site : Site 4
 Location : 42.948550, -73.790036

TSTData.com

Survey Date : 2021-04-28, Wednesday

Project	Labella
Project Code	Labella
Site Name	13
Legs and Movements	All Processed Legs & Move
Bin Size	15 minutes
Survey Date	2021-10-27, Wednesday
Location	13
Latitude and Longitude	42.900130, -78.844602

	Start	End	PHF
Forced Peak AM	2021/10/27 07:30:00	2021/10/27 08:30:00	0.85
Forced Peak PM	2021/10/27 16:30:00	2021/10/27 17:30:00	0.87
AM Peak	2021/10/27 07:30:00	2021/10/27 08:30:00	0.85
PM Peak	2021/10/27 16:30:00	2021/10/27 17:30:00	0.87

Turning Movement Data

Leg Direction	Herman St							Genesee St							Herman St							Genesee St							Total
	Southbound			Westbound				Westbound			Northbound				Northbound			Eastbound											
Start Time	Right	Thru	Left	U-Turn	App Total	Peds CV	Peds CCV	Right	Thru	Left	U-Turn	App Total	Peds CV	Peds CCV	Right	Thru	Left	U-Turn	App Total	Peds CV	Peds CCV	Right	Thru	Left	U-Turn	App Total	Peds CV	Peds CCV	Total
6:30:00 AM	1	7	2	0	10	0	0	1	28	0	0	29	0	0	0	5	1	0	6	0	0	1	13	1	0	15	0	0	60
6:45:00 AM	2	10	3	0	15	0	0	1	51	0	0	52	0	0	2	5	4	0	11	0	0	3	14	0	0	17	0	0	95
Hourly Total	3	17	5	0	25	0	0	2	79	0	0	81	0	0	2	10	5	0	17	0	0	4	27	1	0	32	0	0	155
7:00:00 AM	2	14	2	0	18	0	0	2	38	3	0	43	0	0	0	4	0	0	4	0	0	1	19	0	0	20	0	0	85
7:15:00 AM	2	11	5	0	18	0	0	4	39	0	0	43	0	0	2	7	1	0	10	0	1	0	28	1	0	29	0	0	100
7:30:00 AM	3	16	3	0	22	0	0	5	55	2	0	62	0	0	4	10	1	0	15	0	0	1	26	2	0	29	0	0	128
7:45:00 AM	3	25	4	0	32	0	0	4	99	5	0	108	0	0	3	19	6	0	28	0	0	4	37	0	0	41	0	0	209
Hourly Total	10	66	14	0	90	0	0	15	231	10	0	256	0	0	9	40	8	0	57	0	1	6	110	3	0	119	0	0	522
8:00:00 AM	2	33	5	0	40	0	0	1	85	4	0	90	0	0	0	18	4	0	22	2	2	1	50	1	0	52	0	0	204
8:15:00 AM	3	21	3	0	27	1	1	4	70	2	0	77	0	0	0	17	4	0	21	0	1	4	36	2	0	42	0	0	167
Hourly Total	5	54	8	0	67	1	1	5	155	6	0	167	0	0	0	35	8	0	43	2	3	5	86	3	0	94	0	0	371
4:00:00 PM	1	35	5	0	41	0	1	6	63	2	0	71	0	0	4	35	7	0	46	0	4	8	70	2	0	80	0	0	238
4:15:00 PM	5	29	11	0	45	0	0	4	86	6	0	96	1	0	7	26	7	0	40	0	0	6	76	0	0	82	0	0	263
4:30:00 PM	7	43	10	0	60	1	1	8	91	5	0	104	1	1	10	18	8	0	36	1	0	7	65	4	0	96	0	0	266
4:45:00 PM	3	36	9	0	48	2	0	5	73	7	0	85	1	0	7	29	6	0	42	1	0	7	76	1	0	84	0	0	259
Hourly Total	16	143	35	0	194	3	2	23	283	20	0	326	3	3	28	108	28	0	164	2	4	28	307	7	0	342	0	0	1026
5:00:00 PM	7	26	10	0	43	1	0	4	57	6	1	68	1	1	8	16	6	0	30	0	0	4	62	1	0	67	0	0	208
5:15:00 PM	3	27	11	0	41	0	2	5	46	9	0	60	0	0	6	17	8	0	31	0	3	3	60	2	0	65	0	0	197
5:30:00 PM	4	38	6	0	48	0	2	6	48	9	0	63	2	1	6	16	9	0	31	0	1	3	48	4	0	55	0	0	197
5:45:00 PM	4	28	5	0	37	0	0	2	61	4	0	67	0	0	5	15	8	0	28	0	1	3	43	1	0	47	0	1	179
Hourly Total	18	119	32	0	169	1	4	17	212	28	1	258	3	2	25	64	31	0	120	5	5	13	213	8	0	234	0	1	781
Grand Total	52	399	94	0	545	5	7	62	960	64	1	1088	6	6	64	257	80	0	401	9	13	56	743	22	0	821	0	1	2885
% Approach	9.5%	73.2%	17.2%	0.0%	0.0%	0.0%	0.0%	5.7%	88.2%	5.9%	0.1%	0.0%	0.0%	0.0%	16.0%	64.1%	20.0%	0.0%	0.0%	0.0%	0.0%	6.8%	90.5%	2.7%	0.0%	0.0%	0.0%	0.0%	0.0%
% Total	1.8%	14.0%	3.3%	0.0%	19.1%	0.0%	0.0%	2.2%	33.6%	2.2%	0.0%	38.1%	0.0%	0.0%	2.2%	9.0%	2.8%	0.0%	14.0%	0.0%	0.0%	2.0%	26.0%	0.8%	0.0%	28.8%	0.0%	0.0%	0.0%
Lights	49	395	90	0	534	0	0	57	926	61	1	1045	0	0	59	249	79	0	387	0	0	53	697	16	0	768	0	0	2734
% Lights	94.2%	99.0%	95.7%	0.0%	98.0%	0.0%	0.0%	91.9%	98.6%	95.3%	100.0%	98.0%	0.0%	0.0%	92.2%	98.9%	98.8%	0.0%	96.8%	0.0%	0.0%	94.6%	93.8%	81.8%	0.0%	93.8%	0.0%	0.0%	95.8%
Trucks	0	0	0	0	0	0	0	0	1	0	0	1	0	0	0	0	0	0	0	0	0	0	0	0	0	0	0	0	1
% Trucks	0.0%	0.0%	0.0%	0.0%	0.0%	0.0%	0.0%	0.0%	0.1%	0.0%	0.0%	0.1%	0.0%	0.0%	0.0%	0.0%	0.0%	0.0%	0.0%	0.0%	0.0%	0.0%	0.0%	0.0%	0.0%	0.0%	0.0%	0.0%	0.0%
Buses	2	4	3	0	9	0	0	4	31	3	0	38	0	0	5	9	1	0	14	0	0	3	44	4	0	51	0	0	112
% Buses	3.8%	1.0%	3.2%	0.0%	0.0%	0.0%	0.0%	0.0%	3.2%	4.7%	0.0%	0.0%	0.0%	0.0%	7.8%	3.1%	1.3%	0.0%	0.0%	0.0%	0.0%	5.4%	5.9%	18.2%	0.0%	0.0%	0.0%	0.0%	3.9%
Pedestrians	0	0	0	0	0	5	7	0	0	0	0	0	6	5	0	0	0	0	0	9	13	0	0	0	0	0	0	1	0
% Pedestrians	0.0%	0.0%	0.0%	0.0%	0.0%	100.0%	100.0%	0.0%	0.0%	0.0%	0.0%	0.0%	100.0%	100.0%	0.0%	0.0%	0.0%	0.0%	0.0%	100.0%	100.0%	0.0%	0.0%	0.0%	0.0%	0.0%	0.0%	100.0%	0.0%
Bicycles on Crosswalk	0	0	0	0	0	0	0	0	0	0	0	0	0	0	0	0	0	0	0	0	0	0	0	0	0	0	0	0	0
% Bicycles on Crosswalk	0.0%	0.0%	0.0%	0.0%	0.0%	0.0%	0.0%	0.0%	0.0%	0.0%	0.0%	0.0%	0.0%	0.0%	0.0%	0.0%	0.0%	0.0%	0.0%	0.0%	0.0%	0.0%	0.0%	0.0%	0.0%	0.0%	0.0%	0.0%	0.0%

Project : VBH Malta NY
 Site : Site 4
 Location : 42.948550, -73.790036
 Survey Date : 2021-04-28, Wednesday

Turning Movement Data Plot

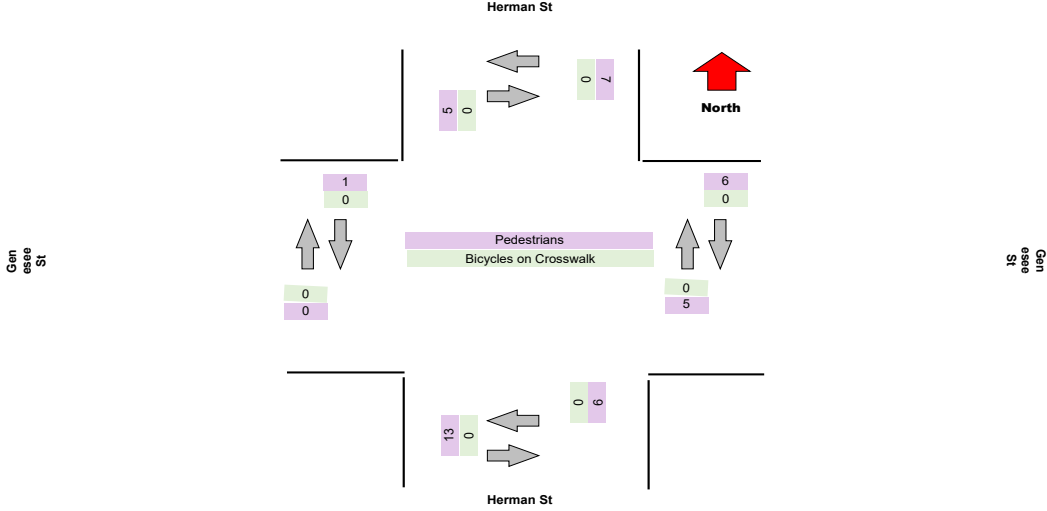
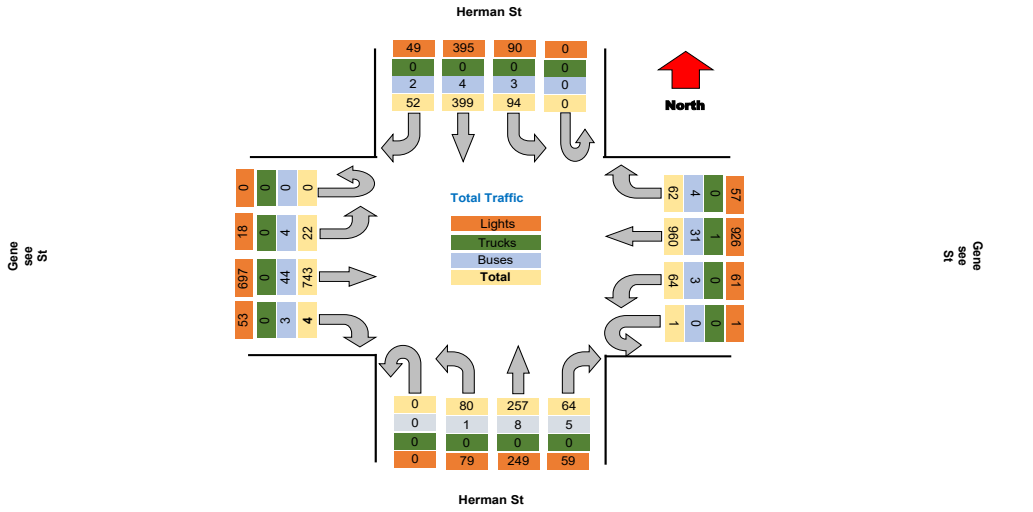

Project : VBH Malta NY
Site : Site 4
Location : 42.948550, -73.790036

TSTData.com

Survey Date : 2021-04-28, Wednesday

Turning Movement Peak Hour Data (AM)

7:30:00 AM

Leg Direction	Herman St Southbound						Genesee St Westbound						Herman St Northbound						Genesee St Eastbound						Total				
	Right	Thru	Left	U-Turn	App Total	Peds CW	Peds CCW	Right	Thru	Left	U-Turn	App Total	Peds CW	Peds CCW	Right	Thru	Left	U-Turn	App Total	Peds CW	Peds CCW	Right	Thru	Left		U-Turn	App Total	Peds CW	Peds CCW
7:30:00 AM	3	16	3	0	22	0	0	5	55	2	0	62	0	0	4	10	1	0	15	0	0	1	26	2	0	29	0	0	128
7:45:00 AM	3	25	4	0	32	0	0	4	99	5	0	108	0	0	3	19	6	0	28	0	0	4	37	0	0	41	0	0	209
8:00:00 AM	2	33	5	0	40	0	0	1	85	4	0	90	0	0	0	18	4	0	22	2	2	1	50	1	0	52	0	0	204
8:15:00 AM	3	21	3	0	27	0	0	4	70	2	0	77	0	0	0	17	4	0	21	0	0	4	36	2	0	42	0	0	167
Grand Total	11	95	15	0	121	0	0	14	309	13	0	337	0	0	7	64	15	0	86	2	2	10	149	5	0	164	0	0	788
% Approach	9.1%	78.5%	12.4%	0.0%	0.0%	0.0%	0.0%	14.2%	85.8%	0.0%	0.0%	0.0%	0.0%	0.0%	45.1%	41.7%	13.2%	0.0%	0.0%	0.0%	0.0%	66.2%	33.8%	0.0%	0.0%	0.0%	0.0%	0.0%	0.0%
% Total	1.6%	13.4%	2.1%	0.0%	17.1%	0.0%	0.0%	2.0%	43.6%	1.8%	0.0%	47.6%	0.0%	0.0%	1.0%	9.0%	2.1%	0.0%	12.1%	0.0%	0.0%	1.4%	21.0%	0.7%	0.0%	23.2%	0.0%	0.0%	0.0%
PHF	0.917	0.720	0.750	0.000	0.756	0.000	0.000	0.700	0.780	0.650	0.000	0.780	0.000	0.000	0.438	0.842	0.625	0.000	0.768	0.000	0.000	0.625	0.745	0.625	0.000	0.788	0.000	0.000	0.847
Lights	11	94	15	0	120	0	0	13	296	13	0	322	0	0	5	60	15	0	80	0	0	9	137	4	0	150	0	0	672
% Lights	100.0%	98.9%	100.0%	0.0%	99.2%	0.0%	0.0%	92.9%	95.8%	100.0%	0.0%	95.5%	0.0%	0.0%	71.4%	93.8%	100.0%	0.0%	93.0%	0.0%	0.0%	90.0%	91.9%	80.0%	0.0%	91.5%	0.0%	0.0%	94.9%
Trucks	0	0	0	0	0	0	0	0	1	0	0	1	0	0	0	0	0	0	0	0	0	0	0	0	0	0	0	0	1
% Trucks	0.0%	0.0%	0.0%	0.0%	0.0%	0.0%	0.0%	0.0%	0.3%	0.0%	0.0%	0.3%	0.0%	0.0%	0.0%	0.0%	0.0%	0.0%	0.0%	0.0%	0.0%	0.0%	0.0%	0.0%	0.0%	0.0%	0.0%	0.0%	0.1%
Buses	0	1	0	0	1	0	0	1	11	0	0	12	0	0	2	4	0	0	6	0	0	1	12	1	0	14	0	0	33
% Buses	0.0%	1.1%	0.0%	0.0%	0.0%	0.0%	0.0%	7.1%	3.6%	0.0%	0.0%	0.0%	0.0%	0.0%	28.6%	6.3%	0.0%	0.0%	0.0%	0.0%	0.0%	10.0%	8.1%	20.0%	0.0%	0.0%	0.0%	4.7%	
Pedestrians	0	0	0	0	0	1	1	0	0	0	0	0	0	0	0	0	0	0	2	3	1	0	0	0	0	0	0	0	
% Pedestrians	0.0%	0.0%	0.0%	0.0%	0.0%	100.0%	100.0%	0.0%	0.0%	0.0%	0.0%	0.0%	0.0%	0.0%	0.0%	0.0%	0.0%	0.0%	0.0%	100.0%	100.0%	0.0%	0.0%	0.0%	0.0%	0.0%	0.0%	0.0%	0.0%
Bicycles on Crosswalk	0	0	0	0	0	0	0	0	0	0	0	0	0	0	0	0	0	0	0	0	0	0	0	0	0	0	0	0	
% Bicycles on Crosswalk	0.0%	0.0%	0.0%	0.0%	0.0%	0.0%	0.0%	0.0%	0.0%	0.0%	0.0%	0.0%	0.0%	0.0%	0.0%	0.0%	0.0%	0.0%	0.0%	0.0%	0.0%	0.0%	0.0%	0.0%	0.0%	0.0%	0.0%	0.0%	0.0%

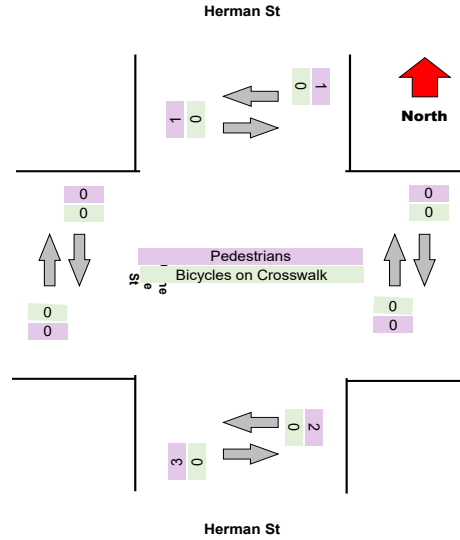
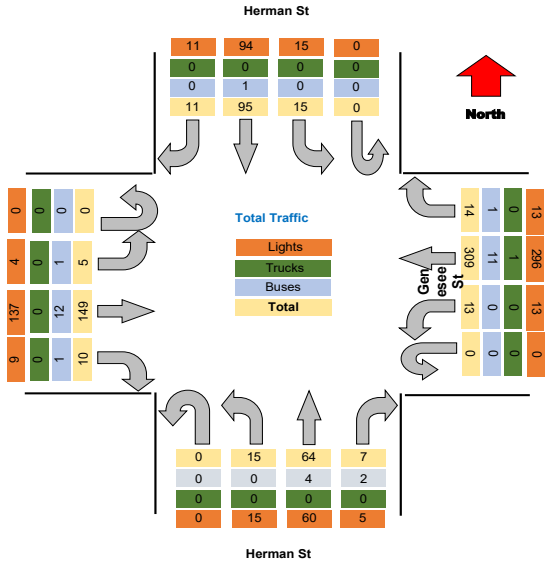

Project : VBH Malta NY
Site : Site 4
Location : 42.948550, -73.790036

TSTData.com

Survey Date : 2021-04-28, Wednesday

Turning Movement Peak Hour Data (PM)

4:30:00 PM

Leg Direction	Herman St								Genesee St								Herman St								Genesee St								Total
	Southbound				Westbound				Northbound				Eastbound																				
Start Time	Right	Thru	Left	U-Turn	App Total	Peds CW	Peds CCW	Right	Thru	Left	U-Turn	App Total	Peds CW	Peds CCW	Right	Thru	Left	U-Turn	App Total	Peds CW	Peds CCW	Right	Thru	Left	U-Turn	App Total	Peds CW	Peds CCW					
4:30:00 PM	7	43	10	0	60	1	1	8	61	5	0	74	1	1	10	18	8	0	36	1	0	7	85	4	0	96	0	0	266				
4:45:00 PM	3	36	9	0	48	2	0	5	73	7	0	85	1	2	7	29	6	0	42	1	0	7	76	1	0	84	0	0	259				
5:00:00 PM	7	26	10	0	43	1	0	4	57	6	1	68	1	1	8	16	6	0	30	5	0	4	62	1	0	67	0	0	208				
5:15:00 PM	3	27	11	0	41	0	0	5	46	9	0	60	0	0	6	17	8	0	31	0	0	3	60	2	0	65	0	0	197				
Grand Total	20	132	40	0	192	4	1	22	237	27	1	287	3	4	31	80	28	0	139	7	0	21	263	6	0	312	0	0	930				
% Approach	10.4%	68.8%	20.8%	0.0%	0.0%	0.0%	0.0%	14.2%	85.8%	0.0%	0.0%	0.0%	0.0%	0.0%	45.1%	41.7%	13.2%	0.0%	0.0%	0.0%	0.0%	0.0%	66.2%	33.8%	0.0%	0.0%	0.0%	0.0%	0.0%				
% Total	2.2%	14.2%	4.3%	0.0%	26.6%	0.0%	0.0%	2.4%	25.5%	2.9%	0.1%	30.9%	0.0%	0.0%	3.3%	8.6%	3.0%	0.0%	14.9%	0.0%	0.0%	2.3%	30.4%	0.9%	0.0%	33.5%	0.0%	0.0%					
PHF	0.714	0.767	0.909	0.000	0.800	0.000	0.000	0.688	0.812	0.750	0.250	0.844	0.000	0.000	0.775	0.690	0.875	0.000	0.827	0.000	0.000	0.750	0.832	0.500	0.000	0.813	0.000	0.000	0.874				
Lights	20	130	39	0	189	0	0	22	228	25	1	276	0	0	30	80	28	0	138	0	0	21	268	7	0	296	0	0	899				
% Lights	100.0%	98.5%	97.5%	0.0%	98.4%	0.0%	0.0%	100.0%	96.2%	92.6%	100.0%	96.2%	0.0%	0.0%	96.8%	100.0%	100.0%	0.0%	99.3%	0.0%	0.0%	100.0%	94.7%	87.5%	0.0%	94.9%	0.0%	0.0%	96.7%				
Trucks	0	0	0	0	0	0	0	0	0	0	0	0	0	0	0	0	0	0	0	0	0	0	0	0	0	0	0	0	0				
% Trucks	0.0%	0.0%	0.0%	0.0%	0.0%	0.0%	0.0%	0.0%	0.0%	0.0%	0.0%	0.0%	0.0%	0.0%	0.0%	0.0%	0.0%	0.0%	0.0%	0.0%	0.0%	0.0%	0.0%	0.0%	0.0%	0.0%	0.0%	0.0%	0.0%				
Buses	0	2	0	0	2	0	0	0	8	2	0	10	0	0	1	0	0	0	1	0	0	0	14	1	0	15	0	0	28				
% Buses	0.0%	1.5%	0.0%	0.0%	0.0%	0.0%	0.0%	0.0%	3.4%	7.4%	0.0%	0.0%	0.0%	0.0%	3.2%	0.0%	0.0%	0.0%	0.0%	0.0%	0.0%	4.9%	12.5%	0.0%	0.0%	0.0%	0.0%	3.0%					
Pedestrians	0	0	0	0	0	4	3	0	0	0	0	0	3	4	0	0	0	0	0	7	3	0	0	0	0	0	0	0					
% Pedestrians	0.0%	0.0%	0.0%	0.0%	0.0%	100.0%	100.0%	0.0%	0.0%	0.0%	0.0%	0.0%	100.0%	100.0%	0.0%	0.0%	0.0%	0.0%	0.0%	0.0%	100.0%	100.0%	0.0%	0.0%	0.0%	0.0%	0.0%	0.0%					
Bicycles on Crosswalk	0	0	0	0	0	0	0	0	0	0	0	0	0	0	0	0	0	0	0	0	0	0	0	0	0	0	0	0	0				
% Bicycles on Crosswalk	0.0%	0.0%	0.0%	0.0%	0.0%	0.0%	0.0%	0.0%	0.0%	0.0%	0.0%	0.0%	0.0%	0.0%	0.0%	0.0%	0.0%	0.0%	0.0%	0.0%	0.0%	0.0%	0.0%	0.0%	0.0%	0.0%	0.0%	0.0%	0.0%				

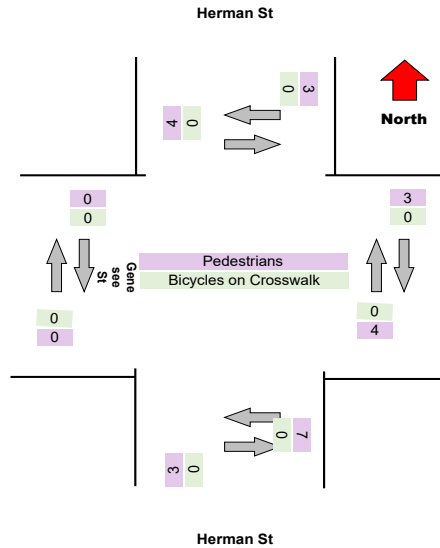
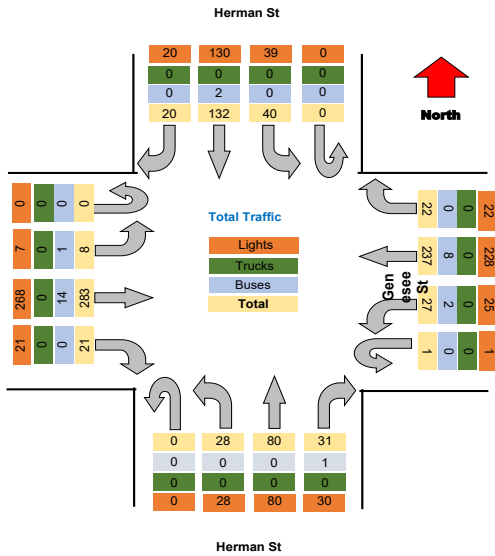

Project : VBH Malta NY
 Site : Site 4
 Location : 42.948550, -73.790036
 Survey Date : 2021-04-28, Wednesday

Turning Movement Data Plot

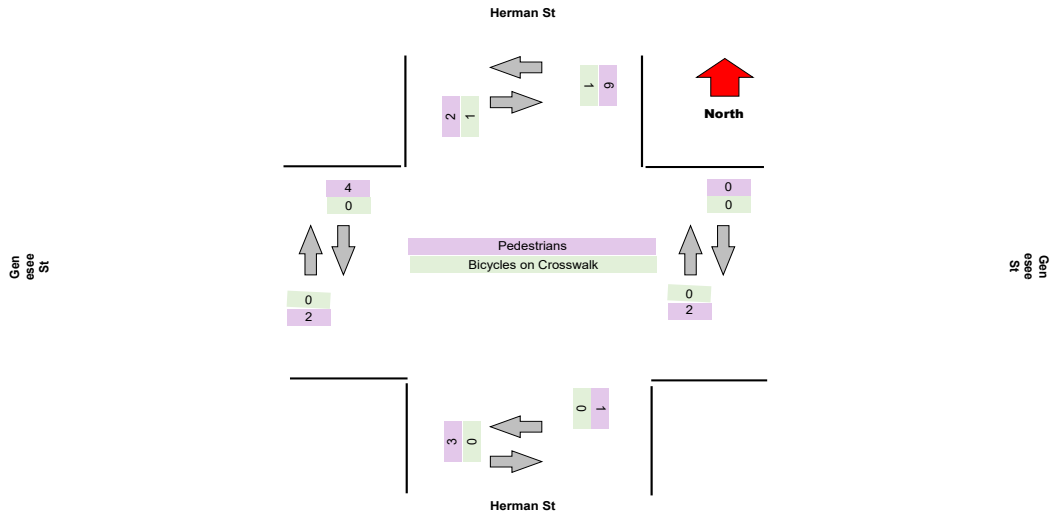
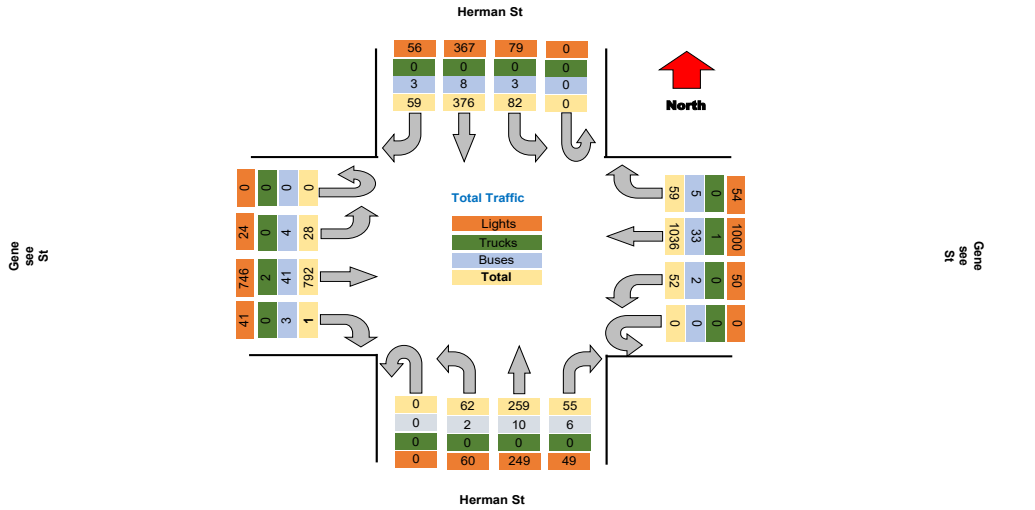

Turning Movement Peak Hour Data (AM)

7:30:00 AM

Leg Direction	Herman St					Genesee St					Herman St					Genesee St					Total							
	Southbound					Westbound					Northbound					Eastbound												
Start Time	Right	Thru	Left	U-Turn	App Total	Peds CW	Peds CCW	Right	Thru	Left	U-Turn	App Total	Peds CW	Peds CCW	Right	Thru	Left	U-Turn	App Total	Peds CW	Peds CCW	Right	Thru	Left	U-Turn	App Total	Peds CW	Peds CCW
7:30:00 AM	1	15	1	0	17	0	0	0	70	1	0	71	0	0	1	7	3	0	11	0	0	1	29	2	0	32	0	0
7:45:00 AM	1	26	5	0	32	0	0	2	103	5	0	110	0	0	2	20	4	0	26	0	0	0	40	1	0	41	0	0
8:00:00 AM	6	20	11	0	37	0	0	3	76	5	0	84	0	0	0	12	6	0	18	0	0	0	60	3	0	63	0	0
8:15:00 AM	2	15	10	0	27	0	0	3	75	1	0	80	0	0	2	11	3	0	16	0	0	2	30	4	0	36	0	0
Grand Total	10	76	27	0	113	0	0	8	325	12	0	345	0	0	5	50	16	0	71	0	0	3	159	10	0	172	0	0
% Approach	8.8%	67.3%	23.9%	0.0%	0.0%	0.0%	0.0%	14.2%	85.8%	0.0%	0.0%	0.0%	0.0%	0.0%	45.1%	41.7%	13.2%	0.0%	0.0%	0.0%	0.0%	0.0%	66.2%	33.8%	0.0%	0.0%	0.0%	0.0%
% Total	1.4%	10.8%	3.9%	0.0%	16.1%	0.0%	0.0%	1.1%	46.4%	1.7%	0.0%	49.2%	0.0%	0.0%	0.7%	7.1%	2.3%	0.0%	10.1%	0.0%	0.0%	0.4%	22.7%	1.4%	0.0%	24.5%	0.0%	0.0%
PHF	0.417	0.731	0.614	0.000	0.764	0.000	0.000	0.667	0.789	0.600	0.000	0.724	0.000	0.000	0.625	0.625	0.667	0.000	0.683	0.000	0.000	0.375	0.663	0.625	0.000	0.683	0.000	0.000
Lights	10	75	27	0	112	0	0	7	312	12	0	331	0	0	3	46	16	0	65	0	0	2	143	9	0	154	0	0
% Lights	100.0%	98.7%	100.0%	0.0%	99.1%	0.0%	0.0%	87.5%	96.0%	100.0%	0.0%	95.9%	0.0%	0.0%	60.0%	92.0%	100.0%	0.0%	91.5%	0.0%	0.0%	66.7%	89.9%	90.0%	0.0%	89.5%	0.0%	0.0%
Trucks	0	0	0	0	0	0	0	0	1	0	0	1	0	0	0	0	0	0	0	0	0	0	2	0	0	2	0	0
% Trucks	0.0%	0.0%	0.0%	0.0%	0.0%	0.0%	0.0%	0.0%	0.3%	0.0%	0.0%	0.3%	0.0%	0.0%	0.0%	0.0%	0.0%	0.0%	0.0%	0.0%	0.0%	0.0%	1.3%	0.0%	0.0%	1.2%	0.0%	0.0%
Buses	0	1	0	0	1	0	0	1	12	0	0	13	0	0	2	4	0	0	6	0	0	1	14	1	0	16	0	0
% Buses	0.0%	1.3%	0.0%	0.0%	0.0%	0.0%	0.0%	12.5%	3.7%	0.0%	0.0%	0.0%	0.0%	0.0%	40.0%	8.0%	0.0%	0.0%	0.0%	0.0%	0.0%	33.3%	8.8%	10.0%	0.0%	0.0%	0.0%	
Pedestrians	0	0	0	0	0	0	0	0	0	0	0	0	0	0	0	0	0	0	0	0	0	0	0	0	0	0	0	0
% Pedestrians	0.0%	0.0%	0.0%	0.0%	0.0%	0.0%	0.0%	0.0%	0.0%	0.0%	0.0%	0.0%	0.0%	0.0%	0.0%	0.0%	0.0%	0.0%	0.0%	0.0%	0.0%	0.0%	0.0%	0.0%	0.0%	0.0%	0.0%	0.0%
Bicycles on Crosswalk	0	0	0	0	0	0	0	0	0	0	0	0	0	0	0	0	0	0	0	0	0	0	0	0	0	0	0	0
% Bicycles on Crosswalk	0.0%	0.0%	0.0%	0.0%	0.0%	0.0%	0.0%	0.0%	0.0%	0.0%	0.0%	0.0%	0.0%	0.0%	0.0%	0.0%	0.0%	0.0%	0.0%	0.0%	0.0%	0.0%	0.0%	0.0%	0.0%	0.0%	0.0%	0.0%

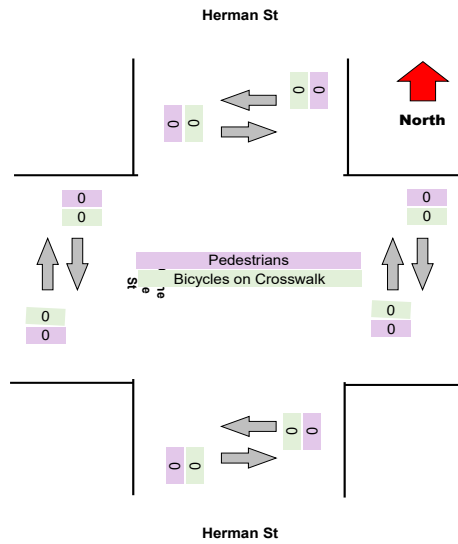
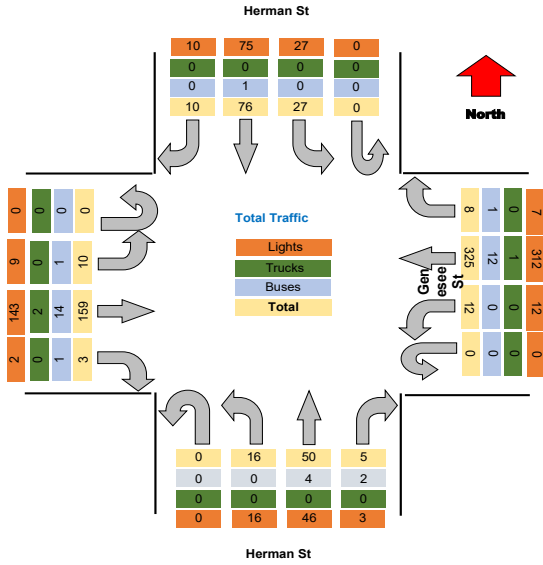

Turning Movement Peak Hour Data (PM)

4:30:00 PM

Leg Direction	Herman St										Genesee St										Herman St										Genesee St										Total
	Southbound					Westbound					Northbound					Eastbound					Northbound					Eastbound															
	Right	Thru	Left	U-Turn	App Total	Right	Thru	Left	U-Turn	App Total	Right	Thru	Left	U-Turn	App Total	Right	Thru	Left	U-Turn	App Total	Right	Thru	Left	U-Turn	App Total	Right	Thru	Left	U-Turn	App Total	Right	Thru	Left	U-Turn	App Total						
4:30:00 PM	7	30	10	0	47	6	85	3	0	94	9	28	4	0	41	9	91	2	0	102	2	61	1	0	64	2	61	1	0	64	7	60	4	0	71	5	75	3	0	83	284
4:45:00 PM	2	35	11	0	48	8	62	2	0	72	3	19	9	0	31	2	61	1	0	64	2	61	1	0	64	7	60	4	0	71	5	75	3	0	83	216					
5:00:00 PM	0	25	5	0	30	5	67	10	0	82	3	26	3	0	32	0	0	0	0	0	0	0	0	0	0	0	0	0	0	0	0	0	0	0	0	0					
5:15:00 PM	8	30	4	0	42	3	84	5	0	92	5	18	3	0	26	1	5	75	3	83	5	75	3	0	83	0	0	0	0	0	0	0	0	0	0	243					
Grand Total	17	129	30	0	176	22	298	20	0	340	20	91	19	0	130	23	287	10	0	320	2	61	1	0	64	7	60	4	0	71	5	75	3	0	83	957					
% Approach	10.2%	71.9%	18.0%	0.0%	0.0%	14.2%	85.8%	0.0%	0.0%	0.0%	45.1%	41.7%	13.2%	0.0%	0.0%	0.0%	66.2%	33.8%	0.0%	0.0%	0.0%	66.2%	33.8%	0.0%	0.0%	2.4%	30.0%	1.0%	0.0%	33.4%	0.0%	0.0%	0.0%	0.0%	0.0%	0.842					
% Total	1.8%	12.5%	3.1%	0.0%	17.5%	2.3%	31.1%	2.1%	0.0%	35.5%	2.1%	9.5%	2.0%	0.0%	13.6%	0.0%	10.0%	10.0%	0.0%	33.4%	0.0%	10.0%	10.0%	0.0%	33.4%	2.4%	30.0%	1.0%	0.0%	33.4%	0.0%	0.0%	0.0%	0.0%	0.0%	0.842					
PHF	0.531	0.857	0.682	0.000	0.870	0.688	0.876	0.500	0.000	0.904	0.556	0.813	0.528	0.000	0.793	0.639	0.788	0.625	0.000	0.784	0.000	0.000	0.000	0.000	0.000	0.639	0.788	0.625	0.000	0.784	0.000	0.000	0.000	0.000	0.000	0.842					
Lights	17	114	29	0	160	21	287	19	0	327	17	90	17	0	124	22	274	9	0	305	0	0	0	0	0	22	274	9	0	305	0	0	0	0	0	916					
% Lights	100.0%	85.0%	96.7%	0.0%	95.8%	95.5%	96.3%	95.0%	0.0%	96.2%	85.0%	98.0%	89.5%	0.0%	95.4%	95.7%	95.5%	90.0%	0.0%	95.3%	0.0%	0.0%	0.0%	0.0%	0.0%	95.7%	95.5%	90.0%	0.0%	95.3%	0.0%	0.0%	0.0%	0.0%	0.0%	95.7%					
Trucks	0	0	0	0	0	0	0	0	0	0	0	0	0	0	0	0	0	0	0	0	0	0	0	0	0	0	0	0	0	0	0	0	0	0	0	0					
% Trucks	0.0%	0.0%	0.0%	0.0%	0.0%	0.0%	0.0%	0.0%	0.0%	0.0%	0.0%	0.0%	0.0%	0.0%	0.0%	0.0%	0.0%	0.0%	0.0%	0.0%	0.0%	0.0%	0.0%	0.0%	0.0%	0.0%	0.0%	0.0%	0.0%	0.0%	0.0%	0.0%	0.0%	0.0%	0.0%	0.0%					
Buses	0	5	1	0	6	1	10	1	0	12	3	1	2	0	6	1	11	1	0	13	0	0	0	0	0	1	11	1	0	13	0	0	0	0	0	37					
% Buses	0.0%	4.2%	3.3%	0.0%	0.0%	4.5%	3.4%	5.0%	0.0%	0.0%	15.0%	1.1%	10.5%	0.0%	0.0%	4.3%	3.8%	10.0%	0.0%	0.0%	0.0%	0.0%	0.0%	0.0%	0.0%	4.3%	3.8%	10.0%	0.0%	0.0%	0.0%	0.0%	0.0%	0.0%	0.0%	3.9%					
Pedestrians	0	0	0	0	0	0	0	0	0	0	0	0	0	0	0	0	0	0	0	0	0	0	0	0	0	0	0	0	0	0	0	0	0	0	0	0					
% Pedestrians	0.0%	0.0%	0.0%	0.0%	0.0%	0.0%	0.0%	0.0%	0.0%	0.0%	0.0%	0.0%	0.0%	0.0%	0.0%	0.0%	0.0%	0.0%	0.0%	0.0%	0.0%	0.0%	0.0%	0.0%	0.0%	0.0%	0.0%	0.0%	0.0%	0.0%	0.0%	0.0%	0.0%	0.0%	0.0%	0.0%					
Bicycles on Crosswalk	0	0	0	0	0	0	0	0	0	0	0	0	0	0	0	0	0	0	0	0	0	0	0	0	0	0	0	0	0	0	0	0	0	0	0	0					
% Bicycles on Crosswalk	0.0%	0.0%	0.0%	0.0%	0.0%	0.0%	0.0%	0.0%	0.0%	0.0%	0.0%	0.0%	0.0%	0.0%	0.0%	0.0%	0.0%	0.0%	0.0%	0.0%	0.0%	0.0%	0.0%	0.0%	0.0%	0.0%	0.0%	0.0%	0.0%	0.0%	0.0%	0.0%	0.0%	0.0%	0.0%	0.0%					

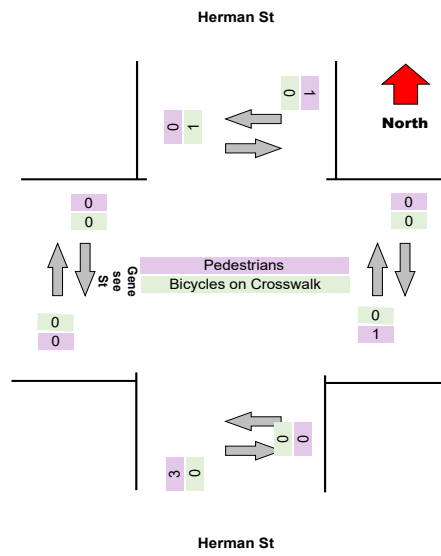
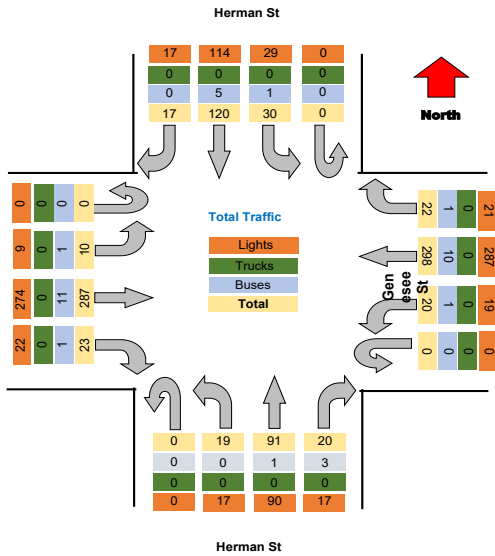

Turning Movement Data Plot

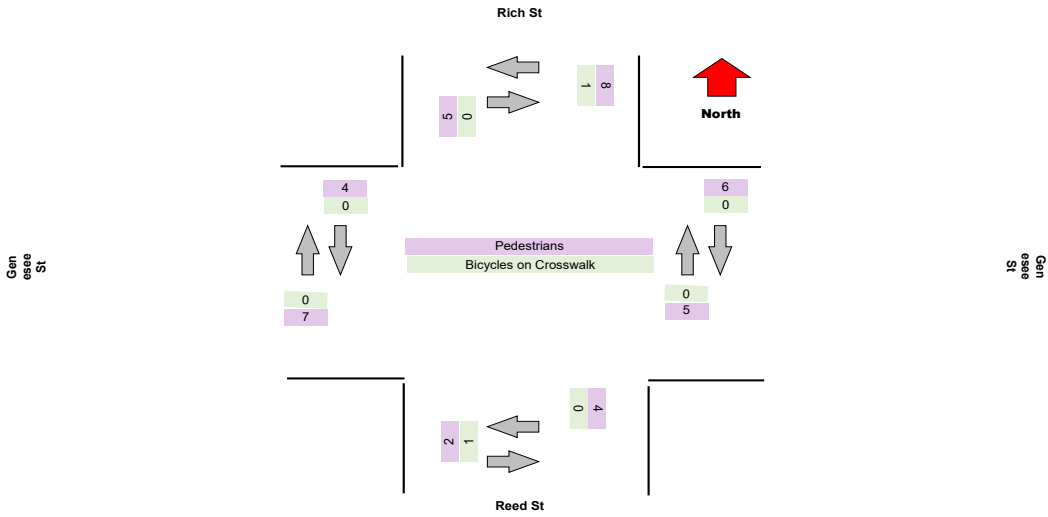
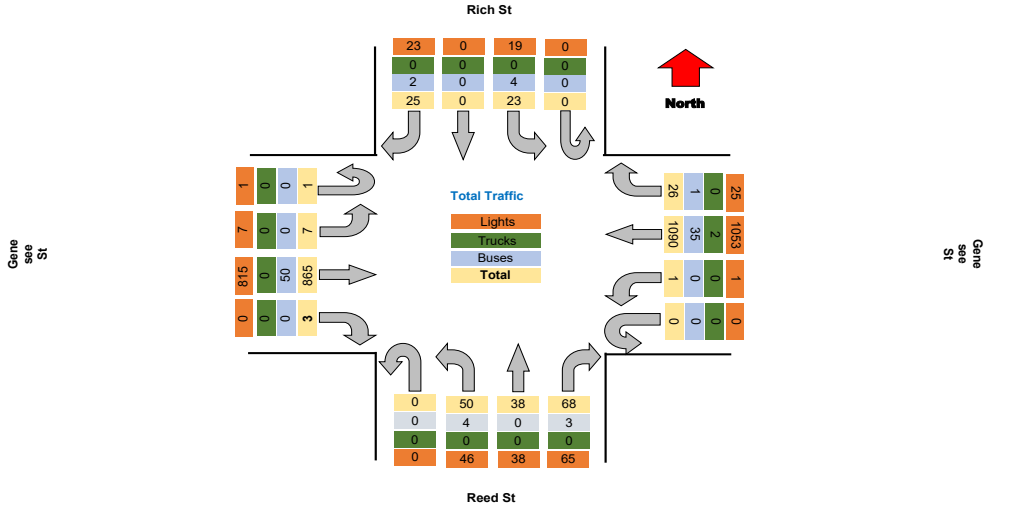

Turning Movement Peak Hour Data (AM)

7:30:00 AM

Leg Direction	Rich St						Genesee St						Reed St						Genesee St						Total				
	Southbound			Northbound			Westbound			Eastbound			Northbound			Eastbound													
Start Time	Right	Thru	Left	U-Turn	App Total	Peds CW	Peds CCW	Right	Thru	Left	U-Turn	App Total	Peds CW	Peds CCW	Right	Thru	Left	U-Turn	App Total	Peds CW	Peds CCW	Right	Thru	Left	U-Turn	App Total	Peds CW	Peds CCW	
7:30:00 AM	0	0	1	0	1	1	0	2	79	0	0	81	0	0	3	2	6	0	11	0	0	0	23	0	0	23	3	2	116
7:45:00 AM	0	0	1	0	1	0	0	2	100	0	0	102	2	0	2	0	0	0	4	0	0	0	45	0	0	45	0	0	162
8:00:00 AM	2	0	1	0	3	1	0	0	106	0	0	106	0	0	8	0	4	0	12	0	0	0	62	0	0	62	2	0	183
8:15:00 AM	1	0	2	0	3	1	0	3	83	0	0	87	0	0	1	1	2	0	4	0	0	0	38	1	0	39	2	0	133
Grand Total	3	0	5	0	8	3	0	7	368	0	0	378	2	0	14	3	12	0	31	0	0	0	168	1	0	169	3	2	684
% Approach	37.5%	0.0%	62.5%	0.0%	0.0%	0.0%	0.0%	14.2%	85.8%	0.0%	0.0%	0.0%	0.0%	0.0%	45.1%	41.7%	13.2%	0.0%	0.0%	0.0%	0.0%	0.0%	66.2%	33.8%	0.0%	0.0%	0.0%	0.0%	0.0%
% Total	0.5%	0.0%	0.9%	0.0%	1.4%	0.0%	0.0%	1.2%	63.0%	0.0%	0.0%	64.4%	0.0%	0.0%	2.4%	0.5%	2.1%	0.0%	5.3%	0.0%	0.0%	0.0%	28.8%	0.2%	0.0%	28.9%	0.0%	0.0%	0.0%
PHF	0.375	0.000	0.625	0.000	0.667	0.000	0.000	0.583	0.868	0.000	0.000	0.887	0.000	0.000	0.438	0.375	0.500	0.000	0.646	0.000	0.000	0.000	0.677	0.250	0.000	0.681	0.000	0.000	0.798
Lights	3	0	3	0	6	0	0	7	357	0	0	364	0	0	14	3	10	0	27	0	0	0	150	1	0	151	0	0	548
% Lights	100.0%	0.0%	60.0%	0.0%	75.0%	0.0%	0.0%	100.0%	97.0%	0.0%	0.0%	96.8%	0.0%	0.0%	100.0%	100.0%	83.3%	0.0%	87.1%	0.0%	0.0%	0.0%	89.3%	100.0%	0.0%	89.3%	0.0%	0.0%	93.8%
Trucks	0	0	0	0	0	0	0	0	1	0	0	1	0	0	0	0	0	0	0	0	0	0	0	0	0	0	0	0	1
% Trucks	0.0%	0.0%	0.0%	0.0%	0.0%	0.0%	0.0%	0.0%	0.3%	0.0%	0.0%	0.3%	0.0%	0.0%	0.0%	0.0%	0.0%	0.0%	0.0%	0.0%	0.0%	0.0%	0.0%	0.0%	0.0%	0.0%	0.0%	0.0%	0.2%
Buses	0	0	2	0	2	0	0	0	10	0	0	10	0	0	0	0	2	0	2	0	0	0	18	0	0	18	0	0	32
% Buses	0.0%	0.0%	40.0%	0.0%	0.0%	0.0%	0.0%	0.0%	2.7%	0.0%	0.0%	0.0%	0.0%	0.0%	0.0%	0.0%	16.7%	0.0%	0.0%	0.0%	0.0%	0.0%	10.7%	0.0%	0.0%	0.0%	0.0%	0.0%	5.5%
Pedestrians	0	0	0	0	0	3	1	0	0	0	0	0	2	0	0	0	0	0	0	0	0	0	0	0	0	0	5	2	0
% Pedestrians	0.0%	0.0%	0.0%	0.0%	0.0%	100.0%	100.0%	0.0%	0.0%	0.0%	0.0%	0.0%	100.0%	0.0%	0.0%	0.0%	0.0%	0.0%	0.0%	0.0%	0.0%	0.0%	0.0%	0.0%	0.0%	0.0%	100.0%	100.0%	0.0%
Bicycles on Crosswalk	0	0	0	0	0	0	0	0	0	0	0	0	0	0	0	0	0	0	0	0	0	0	0	0	0	0	0	0	0
% Bicycles on Crosswalk	0.0%	0.0%	0.0%	0.0%	0.0%	0.0%	0.0%	0.0%	0.0%	0.0%	0.0%	0.0%	0.0%	0.0%	0.0%	0.0%	0.0%	0.0%	0.0%	0.0%	0.0%	0.0%	0.0%	0.0%	0.0%	0.0%	0.0%	0.0%	0.0%

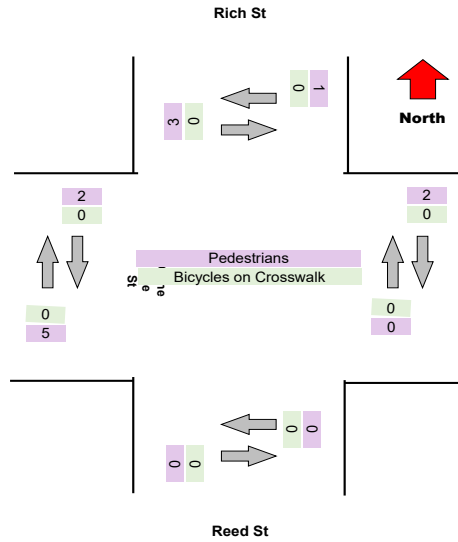
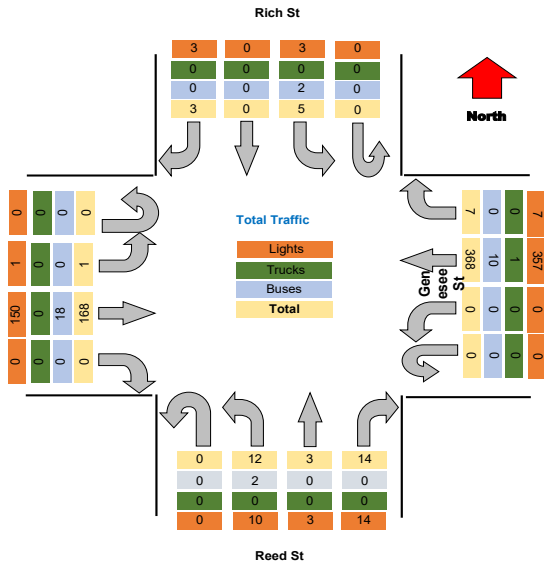

Turning Movement Peak Hour Data (PM)

4:30:00 PM

Leg Direction	Rich St				Genesee St				Reed St				Genesee St				Total												
	Southbound				Westbound				Northbound				Eastbound																
Start Time	Right	Thru	Left	U-Turn	App Total	Peds CW	Peds CCW	Right	Thru	Left	U-Turn	App Total	Peds CW	Peds CCW	Right	Thru	Left	U-Turn	App Total	Peds CW	Peds CCW								
4:30:00 PM	2	0	6	0	8	0	1	2	54	0	0	56	0	1	4	4	3	0	11	2	0	103	0	0	178				
4:45:00 PM	3	0	0	0	3	0	0	2	77	0	0	79	0	0	8	4	3	0	15	0	0	86	1	0	87	0	0	184	
5:00:00 PM	0	0	1	0	1	1	0	2	69	0	0	71	0	0	7	2	6	0	15	0	0	85	0	0	85	0	0	172	
5:15:00 PM	5	0	2	0	7	0	0	1	61	1	0	63	0	0	6	6	2	0	14	0	1	87	0	0	87	0	0	151	
Grand Total	10	0	9	0	19	1	1	7	251	1	0	259	0	1	25	16	14	0	55	2	1	341	1	0	342	0	0	685	
% Approach	52.6%	0.0%	47.4%	0.0%	0.0%	0.0%	0.0%	14.2%	85.8%	0.0%	0.0%	0.0%	0.0%	0.0%	45.1%	41.7%	13.2%	0.0%	0.0%	0.0%	0.0%	0.0%	66.2%	33.8%	0.0%	0.0%	0.0%	0.0%	0.0%
% Total	1.5%	0.0%	1.3%	0.0%	2.8%	0.0%	0.0%	1.0%	38.1%	0.1%	0.0%	39.3%	0.0%	0.0%	3.6%	2.3%	2.0%	0.0%	8.0%	0.0%	0.0%	0.0%	49.8%	0.1%	0.0%	49.9%	0.0%	0.0%	0.0%
PHF	0.500	0.000	0.375	0.000	0.594	0.000	0.000	0.875	0.847	0.250	0.000	0.851	0.000	0.000	0.781	0.667	0.583	0.000	0.917	0.000	0.000	0.000	0.828	0.250	0.000	0.830	0.000	0.000	0.931
Lights	8	0	8	0	16	0	0	7	251	1	0	259	0	0	24	16	14	0	54	0	0	328	1	0	329	0	0	658	
% Lights	80.0%	0.0%	88.9%	0.0%	84.2%	0.0%	0.0%	100.0%	96.2%	100.0%	0.0%	96.3%	0.0%	0.0%	96.0%	100.0%	100.0%	0.0%	98.2%	0.0%	0.0%	0.0%	96.2%	100.0%	0.0%	96.2%	0.0%	0.0%	96.1%
Trucks	0	0	0	0	0	0	0	0	0	0	0	0	0	0	0	0	0	0	0	0	0	0	0	0	0	0	0	0	0
% Trucks	0.0%	0.0%	0.0%	0.0%	0.0%	0.0%	0.0%	0.0%	0.0%	0.0%	0.0%	0.0%	0.0%	0.0%	0.0%	0.0%	0.0%	0.0%	0.0%	0.0%	0.0%	0.0%	0.0%	0.0%	0.0%	0.0%	0.0%	0.0%	0.0%
Buses	2	0	1	0	3	0	0	0	10	0	0	10	0	0	1	0	0	0	1	0	0	0	13	0	0	13	0	0	27
% Buses	20.0%	0.0%	11.1%	0.0%	0.0%	0.0%	0.0%	0.0%	3.8%	0.0%	0.0%	0.0%	0.0%	0.0%	4.0%	0.0%	0.0%	0.0%	0.0%	0.0%	0.0%	0.0%	3.8%	0.0%	0.0%	0.0%	0.0%	0.0%	3.9%
Pedestrians	0	0	0	0	0	1	3	0	0	0	0	0	1	0	0	0	0	0	2	1	0	0	0	0	0	0	0	0	0
% Pedestrians	0.0%	0.0%	0.0%	0.0%	0.0%	100.0%	75.0%	0.0%	0.0%	0.0%	0.0%	0.0%	0.0%	100.0%	0.0%	0.0%	0.0%	0.0%	0.0%	0.0%	0.0%	0.0%	0.0%	0.0%	0.0%	0.0%	0.0%	0.0%	0.0%
Bicycles on Crosswalk	0	0	0	0	0	1	0	0	0	0	0	0	0	0	0	0	0	0	0	0	0	0	0	0	0	0	0	0	0
% Bicycles on Crosswalk	0.0%	0.0%	0.0%	0.0%	0.0%	0.0%	25.0%	0.0%	0.0%	0.0%	0.0%	0.0%	0.0%	0.0%	0.0%	0.0%	0.0%	0.0%	0.0%	0.0%	0.0%	0.0%	0.0%	0.0%	0.0%	0.0%	0.0%	0.0%	0.0%

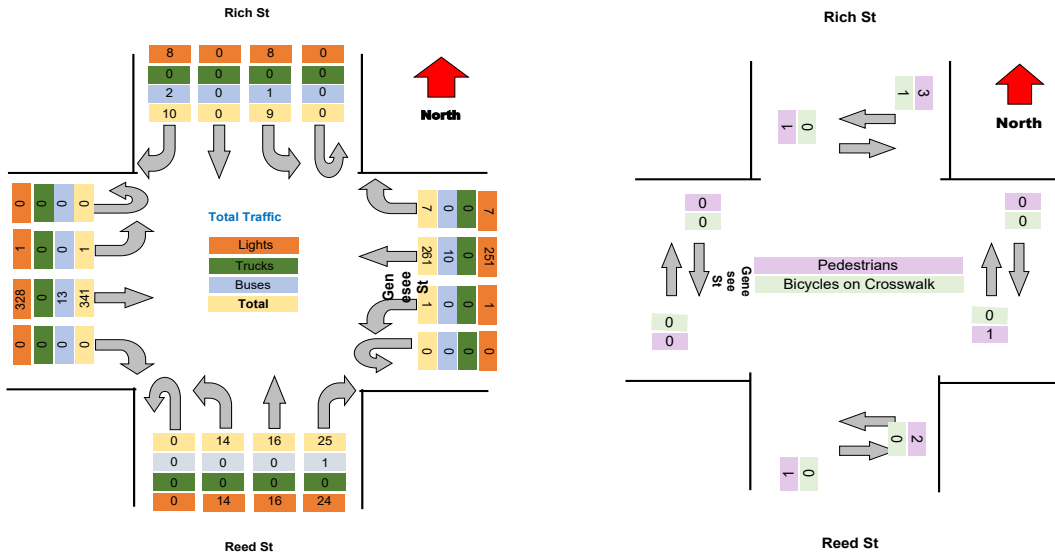

Project : VBH Malta NY
 Site : Site 4
 Location : 42.948550, -73.790036
 Survey Date : 2021-04-28, Wednesday

Turning Movement Data Plot

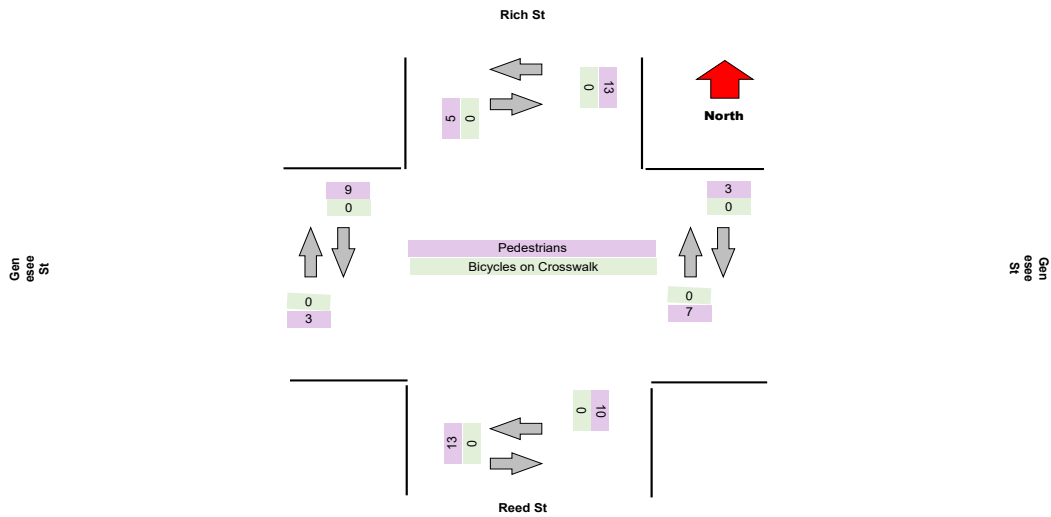
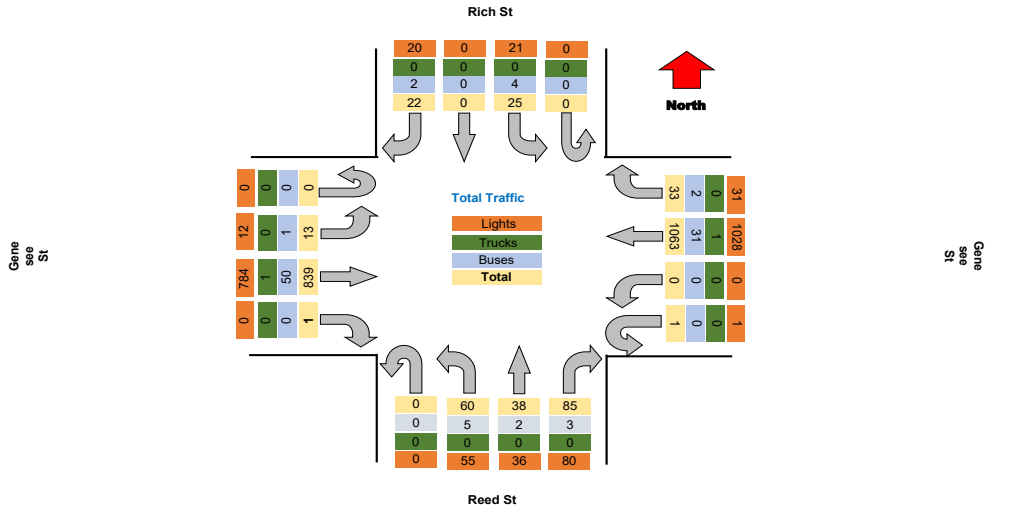

Project : VBH Malta NY
Site : Site 4
Location : 42.948550, -73.790036

TSTData.com

Survey Date : 2021-04-28, Wednesday

Turning Movement Peak Hour Data (AM)

7:30:00 AM

Leg Direction	Rich St						Genesee St						Reed St						Genesee St						Total				
	Southbound			Northbound			Westbound			Eastbound			Northbound			Eastbound													
Start Time	Right	Thru	Left	U-Turn	App Total	Peds CW	Peds CCW	Right	Thru	Left	U-Turn	App Total	Peds CW	Peds CCW	Right	Thru	Left	U-Turn	App Total	Peds CW	Peds CCW	Right	Thru	Left	U-Turn	App Total	Peds CW	Peds CCW	
7:30:00 AM	1	0	0	0	1	0	0	2	56	0	0	58	0	0	1	2	5	0	8	1	0	0	31	0	0	31	0	0	
7:45:00 AM	2	0	3	0	5	0	0	3	104	0	0	107	1	1	3	0	3	0	6	0	0	0	47	1	0	48	1	0	
8:00:00 AM	0	0	1	0	1	0	0	1	101	0	0	104	0	0	5	2	1	0	8	0	2	0	50	0	0	50	0	0	
8:15:00 AM	0	0	2	0	2	1	0	3	64	0	0	67	0	0	0	2	6	0	8	0	1	0	38	1	0	39	0	0	
Grand Total	3	0	6	0	9	1	0	9	325	0	0	336	1	1	9	9	15	0	32	1	3	0	155	2	0	157	1	0	
% Approach	33.3%	0.0%	66.7%	0.0%	0.0%	0.0%	0.0%	14.2%	85.8%	0.0%	0.0%	0.0%	0.0%	0.0%	45.1%	41.7%	13.2%	0.0%	0.0%	0.0%	0.0%	0.0%	66.2%	33.8%	0.0%	0.0%	0.0%	0.0%	
% Total	0.6%	0.0%	1.1%	0.0%	1.7%	0.0%	0.0%	1.7%	59.6%	0.0%	0.0%	61.7%	0.0%	0.0%	1.7%	1.1%	2.8%	0.0%	5.9%	0.0%	0.0%	0.0%	30.5%	0.4%	0.0%	30.8%	0.0%	0.0%	
PHF	0.375	0.000	0.500	0.000	0.450	0.000	0.000	0.750	0.781	0.000	0.000	0.785	0.000	0.000	0.450	0.750	0.625	0.000	1.000	0.000	0.000	0.000	0.830	0.500	0.000	0.840	0.000	0.000	
Lights	3	0	5	0	8	0	0	9	314	0	0	323	0	0	9	5	12	0	26	0	0	0	150	2	0	152	0	0	
% Lights	100.0%	0.0%	83.3%	0.0%	88.9%	0.0%	0.0%	100.0%	96.6%	0.0%	0.0%	96.1%	0.0%	0.0%	100.0%	83.3%	80.0%	0.0%	81.3%	0.0%	0.0%	0.0%	90.4%	100.0%	0.0%	90.5%	0.0%	0.0%	
Trucks	0	0	0	0	0	0	0	0	1	0	0	1	0	0	0	0	0	0	0	0	0	0	1	0	0	1	0	0	
% Trucks	0.0%	0.0%	0.0%	0.0%	0.0%	0.0%	0.0%	0.0%	0.3%	0.0%	0.0%	0.3%	0.0%	0.0%	0.0%	0.0%	0.0%	0.0%	0.0%	0.0%	0.0%	0.0%	0.6%	0.0%	0.0%	0.6%	0.0%	0.0%	
Buses	0	0	1	0	1	0	0	0	9	0	0	9	0	0	0	1	3	0	4	0	0	0	15	0	0	15	0	0	
% Buses	0.0%	0.0%	16.7%	0.0%	0.0%	0.0%	0.0%	0.0%	2.8%	0.0%	0.0%	0.0%	0.0%	0.0%	0.0%	16.7%	20.0%	0.0%	0.0%	0.0%	0.0%	0.0%	9.0%	0.0%	0.0%	0.0%	0.0%	0.0%	
Pedestrians	0	0	0	0	0	1	2	0	0	0	0	0	1	1	0	0	0	0	0	1	3	0	0	0	0	0	1	0	
% Pedestrians	0.0%	0.0%	0.0%	0.0%	0.0%	100.0%	100.0%	0.0%	0.0%	0.0%	0.0%	0.0%	100.0%	100.0%	0.0%	0.0%	0.0%	0.0%	0.0%	0.0%	100.0%	100.0%	0.0%	0.0%	0.0%	0.0%	0.0%	100.0%	0.0%
Bicycles on Crosswalk	0	0	0	0	0	0	0	0	0	0	0	0	0	0	0	0	0	0	0	0	0	0	0	0	0	0	0	0	
% Bicycles on Crosswalk	0.0%	0.0%	0.0%	0.0%	0.0%	0.0%	0.0%	0.0%	0.0%	0.0%	0.0%	0.0%	0.0%	0.0%	0.0%	0.0%	0.0%	0.0%	0.0%	0.0%	0.0%	0.0%	0.0%	0.0%	0.0%	0.0%	0.0%	0.0%	

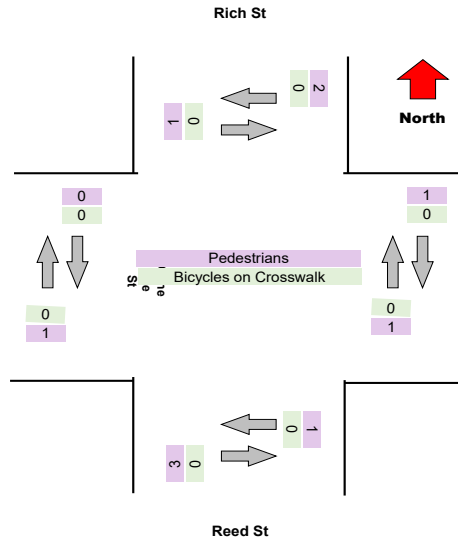
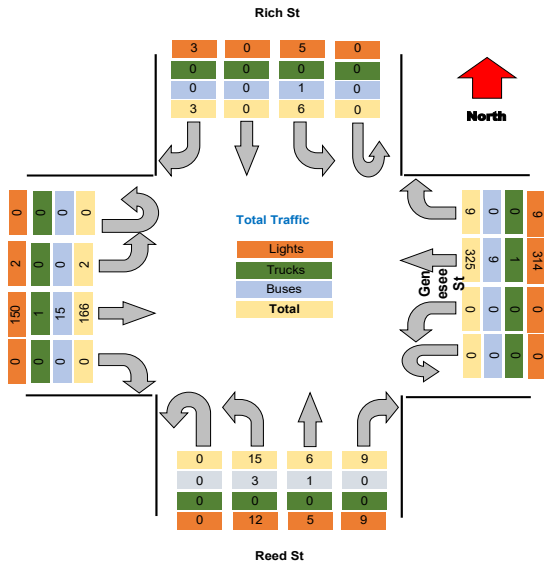

Turning Movement Peak Hour Data (PM)

4:30:00 PM

Leg Direction	Rich St					Genesee St					Reed St					Genesee St					Total				
	Southbound					Westbound					Northbound					Eastbound									
Start Time	Right	Thru	Left	U-Turn	App Total	Peds CW	Peds CCW	Right	Thru	Left	U-Turn	App Total	Peds CW	Peds CCW	Right	Thru	Left	U-Turn	App Total	Peds CW	Peds CCW	Total			
4:30:00 PM	3	0	4	0	7	1	1	3	81	0	1	85	0	0	9	7	1	0	17	0	0	93	0	1	202
4:45:00 PM	5	0	3	0	8	2	1	3	73	0	0	76	0	0	8	1	8	0	17	1	0	85	0	4	186
5:00:00 PM	1	0	3	0	4	1	0	3	60	0	0	63	0	0	7	7	6	0	20	1	0	79	0	0	166
5:15:00 PM	2	0	1	0	3	0	0	2	61	0	0	63	0	0	8	0	2	0	10	0	0	56	0	0	142
Grand Total	11	0	11	0	22	4	2	11	275	0	1	287	0	0	32	15	17	0	64	2	0	319	0	5	696
% Approach	50.0%	0.0%	50.0%	0.0%	0.0%	0.0%	0.0%	14.2%	85.8%	0.0%	0.0%	0.0%	0.0%	0.0%	45.1%	41.7%	13.2%	0.0%	0.0%	0.0%	0.0%	0.0%	0.0%	0.0%	0.0%
% Total	1.6%	0.0%	1.6%	0.0%	3.2%	0.0%	0.0%	1.6%	39.5%	0.0%	0.1%	41.2%	0.0%	0.0%	4.6%	2.2%	2.4%	0.0%	8.2%	0.0%	0.0%	0.0%	0.0%	0.0%	0.0%
PHF	0.550	0.000	0.688	0.000	0.688	0.000	0.000	0.917	0.849	0.000	0.250	0.844	0.000	0.000	0.889	0.536	0.531	0.000	0.800	0.000	0.000	0.000	0.000	0.000	0.861
Lights	9	0	10	0	19	0	0	11	265	0	1	277	0	0	30	14	17	0	61	0	0	305	0	0	662
% Lights	81.8%	0.0%	90.9%	0.0%	86.4%	0.0%	0.0%	100.0%	96.4%	0.0%	100.0%	96.5%	0.0%	0.0%	93.8%	93.3%	100.0%	0.0%	95.3%	0.0%	0.0%	0.0%	0.0%	0.0%	95.1%
Trucks	0	0	0	0	0	0	0	0	0	0	0	0	0	0	0	0	0	0	0	0	0	0	0	0	0
% Trucks	0.0%	0.0%	0.0%	0.0%	0.0%	0.0%	0.0%	0.0%	0.0%	0.0%	0.0%	0.0%	0.0%	0.0%	0.0%	0.0%	0.0%	0.0%	0.0%	0.0%	0.0%	0.0%	0.0%	0.0%	0.0%
Buses	2	0	1	0	3	0	0	0	9	0	0	9	0	0	2	1	0	0	3	0	0	15	0	0	30
% Buses	18.2%	0.0%	9.1%	0.0%	0.0%	0.0%	0.0%	0.0%	3.3%	0.0%	0.0%	0.0%	0.0%	0.0%	6.3%	6.7%	0.0%	0.0%	0.0%	0.0%	0.0%	0.0%	0.0%	0.0%	4.3%
Pedestrians	0	0	0	0	0	4	2	0	0	0	0	0	0	0	0	0	0	0	0	2	0	0	0	5	0
% Pedestrians	0.0%	0.0%	0.0%	0.0%	0.0%	100.0%	100.0%	0.0%	0.0%	0.0%	0.0%	0.0%	0.0%	0.0%	0.0%	0.0%	0.0%	0.0%	0.0%	0.0%	100.0%	0.0%	0.0%	100.0%	0.0%
Bicycles on Crosswalk	0	0	0	0	0	0	0	0	0	0	0	0	0	0	0	0	0	0	0	0	0	0	0	0	0
% Bicycles on Crosswalk	0.0%	0.0%	0.0%	0.0%	0.0%	0.0%	0.0%	0.0%	0.0%	0.0%	0.0%	0.0%	0.0%	0.0%	0.0%	0.0%	0.0%	0.0%	0.0%	0.0%	0.0%	0.0%	0.0%	0.0%	0.0%

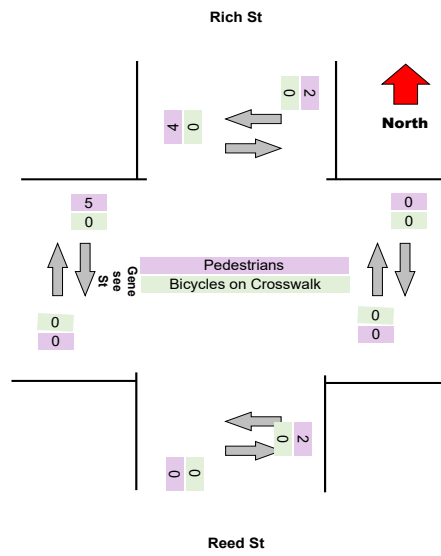
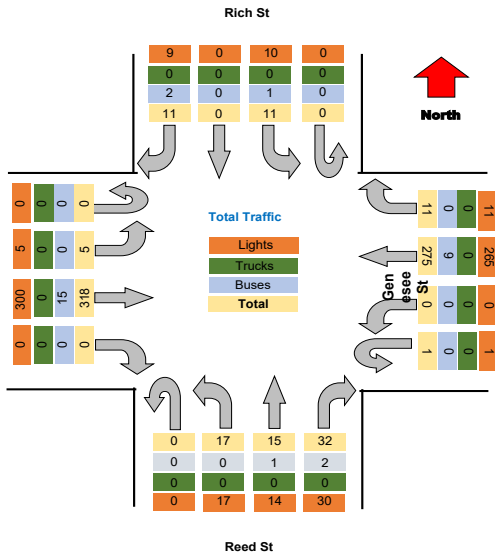

Project : VBH Malta NY
 Site : Site 4
 Location : 42.948550, -73.790036
 Survey Date : 2021-04-28, Wednesday

Turning Movement Data Plot

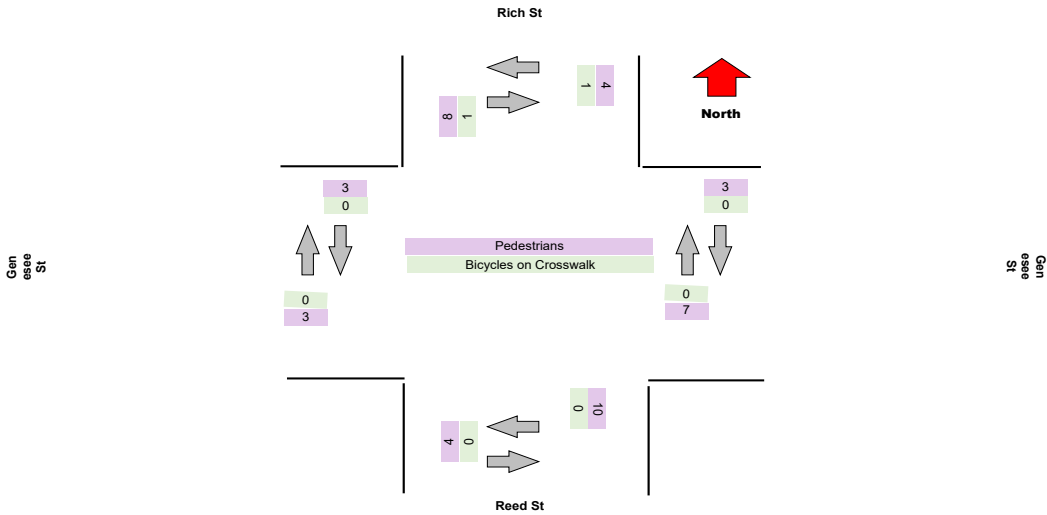
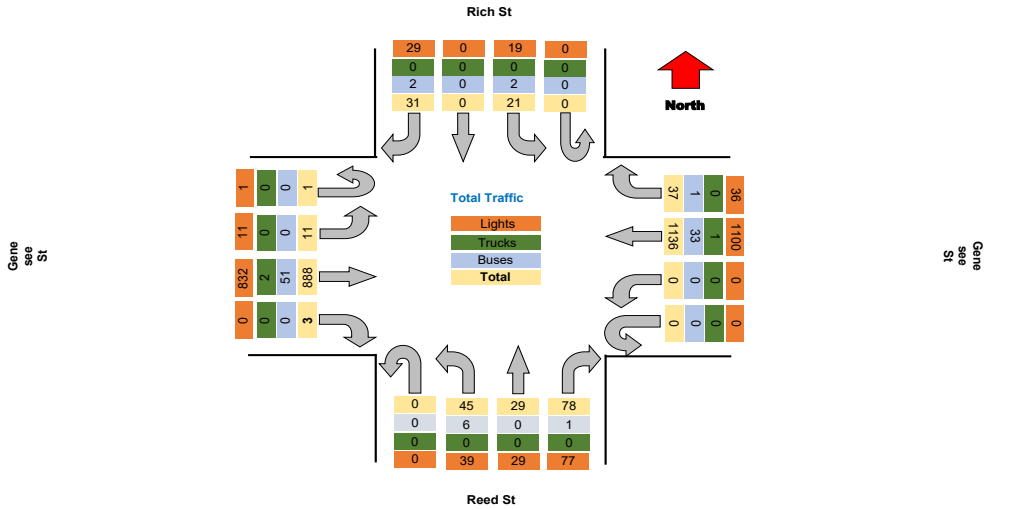

Project : VBH Malta NY
Site : Site 4
Location : 42.948550, -73.790036

TSTData.com

Survey Date : 2021-04-28, Wednesday

Turning Movement Peak Hour Data (AM)

7:30:00 AM

Leg Direction	Rich St							Genesee St							Reed St							Genesee St							Total				
	Southbound				App Total			Westbound				App Total			Northbound				App Total			Eastbound											
Start Time	Right	Thru	Left	U-Turn	Peds CW	Peds CCW	Right	Thru	Left	U-Turn	Peds CW	Peds CCW	Right	Thru	Left	U-Turn	Peds CW	Peds CCW	Right	Thru	Left	U-Turn	Peds CW	Peds CCW	Right	Thru	Left	U-Turn	Peds CW	Peds CCW			
7:30:00 AM	1	0	1	0	2	0	0	3	68	0	0	0	71	0	0	0	0	0	3	1	2	0	6	0	0	0	33	0	0	33	0	0	112
7:45:00 AM	0	0	2	0	2	0	0	3	105	0	0	0	108	1	1	0	0	0	0	5	0	0	7	0	1	0	41	0	0	41	0	0	168
8:00:00 AM	2	0	0	0	2	0	0	2	86	0	0	0	88	0	0	3	0	0	3	0	0	3	1	0	0	69	1	0	70	0	0	163	
8:15:00 AM	1	0	1	0	2	0	0	1	84	0	0	0	85	0	0	2	2	2	0	0	0	0	0	0	0	43	1	0	44	0	0	137	
Grand Total	4	0	4	0	8	0	0	9	343	0	0	0	352	1	1	8	3	9	0	22	1	1	0	0	185	2	0	188	3	0	570		
% Approach	50.0%	0.0%	50.0%	0.0%	0.0%	0.0%	0.0%	14.2%	85.8%	0.0%	0.0%	0.0%	0.0%	0.0%	0.0%	45.1%	41.7%	13.2%	0.0%	0.0%	0.0%	0.0%	0.0%	0.0%	0.0%	66.2%	33.8%	0.0%	0.0%	0.0%	0.0%		
% Total	0.7%	0.0%	0.7%	0.0%	1.4%	0.0%	0.0%	1.6%	60.2%	0.0%	0.0%	0.0%	61.8%	0.0%	0.0%	1.4%	0.5%	1.6%	0.0%	3.9%	0.0%	0.0%	0.0%	0.0%	0.0%	32.6%	0.4%	0.0%	33.0%	0.0%	0.0%		
PHF	0.500	0.000	0.500	0.000	1.000	0.000	0.000	0.750	0.817	0.000	0.000	0.000	0.815	0.000	0.000	0.667	0.375	0.450	0.000	0.786	0.000	0.000	0.000	0.000	0.000	0.674	0.500	0.000	0.671	0.000	0.000	0.874	
Lights	4	0	3	0	7	0	0	9	332	0	0	0	341	0	0	8	3	6	0	17	0	0	0	0	0	167	2	0	169	0	0	534	
% Lights	100.0%	0.0%	75.0%	0.0%	87.5%	0.0%	0.0%	100.0%	96.8%	0.0%	0.0%	0.0%	96.9%	0.0%	0.0%	100.0%	100.0%	66.7%	0.0%	77.3%	0.0%	0.0%	0.0%	0.0%	0.0%	89.8%	100.0%	0.0%	89.9%	0.0%	0.0%	93.7%	
Trucks	0	0	0	0	0	0	0	0	1	0	0	0	1	0	0	0	0	0	0	0	0	0	0	0	0	2	0	0	2	0	0	3	
% Trucks	0.0%	0.0%	0.0%	0.0%	0.0%	0.0%	0.0%	0.0%	0.3%	0.0%	0.0%	0.0%	0.3%	0.0%	0.0%	0.0%	0.0%	0.0%	0.0%	0.0%	0.0%	0.0%	0.0%	0.0%	0.0%	1.1%	0.0%	0.0%	1.1%	0.0%	0.0%	0.5%	
Buses	0	0	1	0	1	0	0	0	10	0	0	0	10	0	0	0	0	3	0	3	0	0	0	0	0	17	0	0	17	0	0	31	
% Buses	0.0%	0.0%	25.0%	0.0%	0.0%	0.0%	0.0%	0.0%	2.9%	0.0%	0.0%	0.0%	0.0%	0.0%	0.0%	0.0%	0.0%	33.3%	0.0%	0.0%	0.0%	0.0%	0.0%	0.0%	0.0%	9.1%	0.0%	0.0%	0.0%	0.0%	0.0%	5.4%	
Pedestrians	0	0	0	0	0	0	0	0	0	0	0	0	0	1	1	0	0	0	0	1	1	0	0	0	0	0	0	0	0	0	0	0	
% Pedestrians	0.0%	0.0%	0.0%	0.0%	0.0%	0.0%	0.0%	0.0%	0.0%	0.0%	0.0%	0.0%	0.0%	100.0%	100.0%	0.0%	0.0%	0.0%	0.0%	0.0%	100.0%	100.0%	0.0%	0.0%	0.0%	0.0%	0.0%	0.0%	0.0%	0.0%	0.0%	0.0%	
Bicycles on Crosswalk	0	0	0	0	0	0	0	0	0	0	0	0	0	0	0	0	0	0	0	0	0	0	0	0	0	0	0	0	0	0	0	0	
% Bicycles on Crosswalk	0.0%	0.0%	0.0%	0.0%	0.0%	0.0%	0.0%	0.0%	0.0%	0.0%	0.0%	0.0%	0.0%	0.0%	0.0%	0.0%	0.0%	0.0%	0.0%	0.0%	0.0%	0.0%	0.0%	0.0%	0.0%	0.0%	0.0%	0.0%	0.0%	0.0%	0.0%	0.0%	

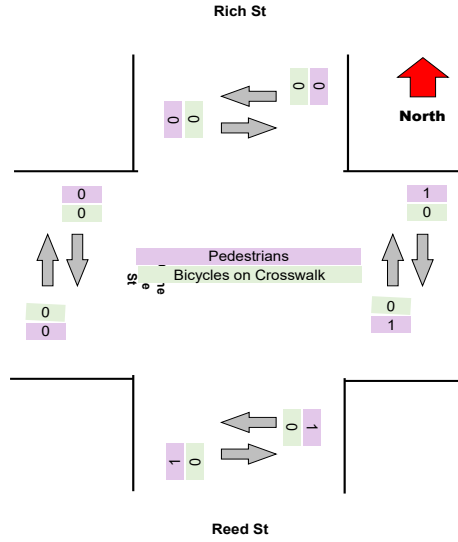
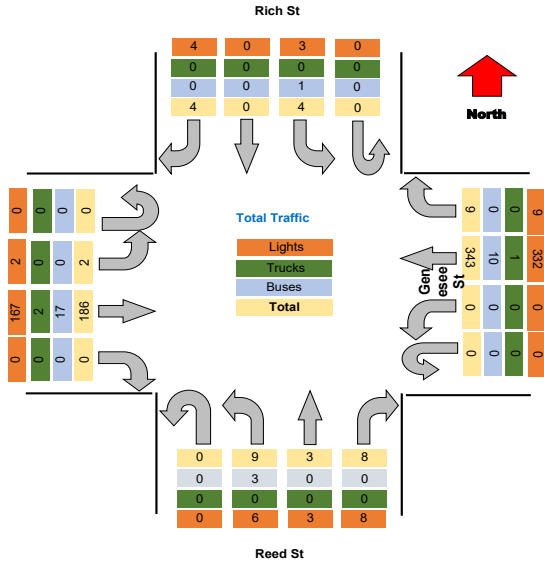

Turning Movement Peak Hour Data (PM)

4:30:00 PM

Leg Direction	Rich St					Genesee St					Reed St					Genesee St					Total								
	Southbound					Westbound					Northbound					Eastbound													
Start Time	Right	Thru	Left	U-Turn	App Total	Peds CW	Peds CCW	Right	Thru	Left	U-Turn	App Total	Peds CW	Peds CCW	Right	Thru	Left	U-Turn	App Total	Peds CW	Peds CCW	Right	Thru	Left	U-Turn	App Total	Peds CW	Peds CCW	
4:30:00 PM	5	0	5	0	10	1	0	4	85	0	0	89	0	0	6	6	5	0	17	1	2	0	98	0	0	98	0	0	214
4:45:00 PM	2	0	2	0	4	0	0	3	75	0	0	78	0	0	5	1	2	0	8	2	0	0	74	0	0	74	0	0	164
5:00:00 PM	3	0	2	0	5	2	0	4	87	0	0	91	0	0	5	2	4	0	11	0	0	0	65	3	0	68	0	0	175
5:15:00 PM	2	0	1	0	3	3	0	2	85	0	0	87	0	0	5	3	4	0	13	2	1	0	80	0	0	80	1	1	183
Grand Total	12	0	10	0	22	6	0	13	332	0	0	345	0	0	22	12	15	0	49	3	3	0	317	3	0	320	1	1	738
% Approach	54.5%	0.0%	45.5%	0.0%	0.0%	0.0%	0.0%	14.2%	85.8%	0.0%	0.0%	0.0%	0.0%	0.0%	45.1%	41.7%	13.2%	0.0%	0.0%	0.0%	0.0%	0.0%	66.2%	33.8%	0.0%	0.0%	0.0%	0.0%	0.0%
% Total	1.6%	0.0%	1.4%	0.0%	3.0%	0.0%	0.0%	1.8%	45.1%	0.0%	0.0%	46.9%	0.0%	0.0%	3.0%	1.6%	2.0%	0.0%	6.7%	0.0%	0.0%	0.0%	43.1%	0.4%	0.0%	43.5%	0.0%	0.0%	0.0%
PHF	0.600	0.000	0.500	0.000	0.550	0.000	0.000	0.813	0.954	0.000	0.000	0.948	0.000	0.000	0.917	0.500	0.750	0.000	0.721	0.000	0.000	0.000	0.809	0.250	0.000	0.816	0.000	0.000	0.860
Lights	10	0	10	0	20	0	0	13	321	0	0	334	0	0	22	12	15	0	49	0	0	0	300	3	0	303	0	0	706
% Lights	83.3%	0.0%	100.0%	0.0%	90.9%	0.0%	0.0%	100.0%	96.7%	0.0%	0.0%	96.8%	0.0%	0.0%	100.0%	100.0%	100.0%	0.0%	100.0%	0.0%	0.0%	0.0%	94.6%	100.0%	0.0%	94.7%	0.0%	0.0%	95.9%
Trucks	0	0	0	0	0	0	0	0	0	0	0	0	0	0	0	0	0	0	0	0	0	0	0	0	0	0	0	0	0
% Trucks	0.0%	0.0%	0.0%	0.0%	0.0%	0.0%	0.0%	0.0%	0.0%	0.0%	0.0%	0.0%	0.0%	0.0%	0.0%	0.0%	0.0%	0.0%	0.0%	0.0%	0.0%	0.0%	0.0%	0.0%	0.0%	0.0%	0.0%	0.0%	0.0%
Buses	2	0	0	0	2	0	0	0	10	0	0	10	0	0	0	0	0	0	0	0	0	0	15	0	0	15	0	0	27
% Buses	16.7%	0.0%	0.0%	0.0%	0.0%	0.0%	0.0%	0.0%	3.0%	0.0%	0.0%	0.0%	0.0%	0.0%	0.0%	0.0%	0.0%	0.0%	0.0%	0.0%	0.0%	4.7%	0.0%	0.0%	0.0%	0.0%	0.0%	3.7%	
Pedestrians	0	0	0	0	0	5	2	0	0	0	0	0	0	0	0	0	0	0	5	3	0	0	0	0	0	0	1	1	0
% Pedestrians	0.0%	0.0%	0.0%	0.0%	0.0%	83.3%	100.0%	0.0%	0.0%	0.0%	0.0%	0.0%	0.0%	0.0%	0.0%	0.0%	0.0%	0.0%	0.0%	100.0%	100.0%	0.0%	0.0%	0.0%	0.0%	0.0%	100.0%	100.0%	0.0%
Bicycles on Crosswalk	0	0	0	0	0	1	0	0	0	0	0	0	0	0	0	0	0	0	0	0	0	0	0	0	0	0	0	0	0
% Bicycles on Crosswalk	0.0%	0.0%	0.0%	0.0%	0.0%	16.7%	0.0%	0.0%	0.0%	0.0%	0.0%	0.0%	0.0%	0.0%	0.0%	0.0%	0.0%	0.0%	0.0%	0.0%	0.0%	0.0%	0.0%	0.0%	0.0%	0.0%	0.0%	0.0%	0.0%

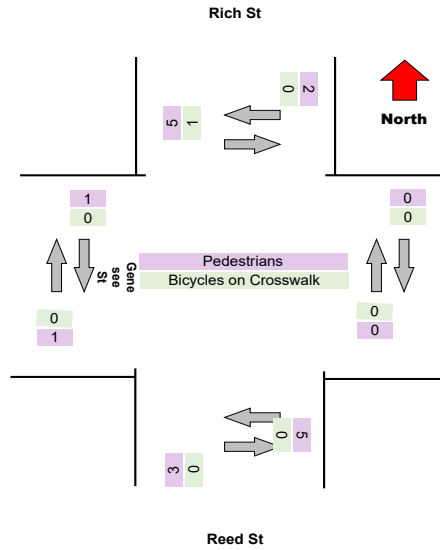
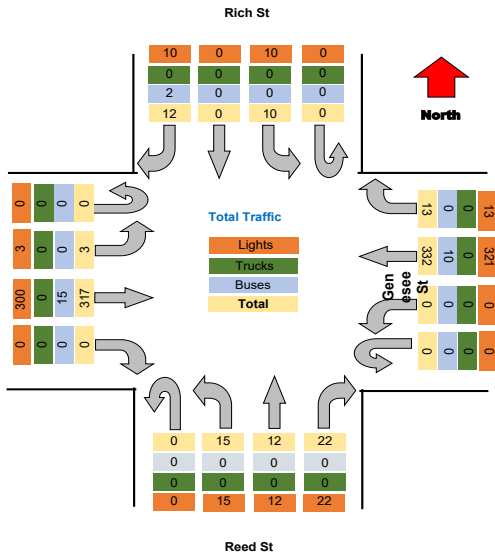

Project : VBH Malta NY
 Site : Site 4
 Location : 42.948550, -73.790036
 Survey Date : 2021-04-28, Wednesday

Turning Movement Data Plot

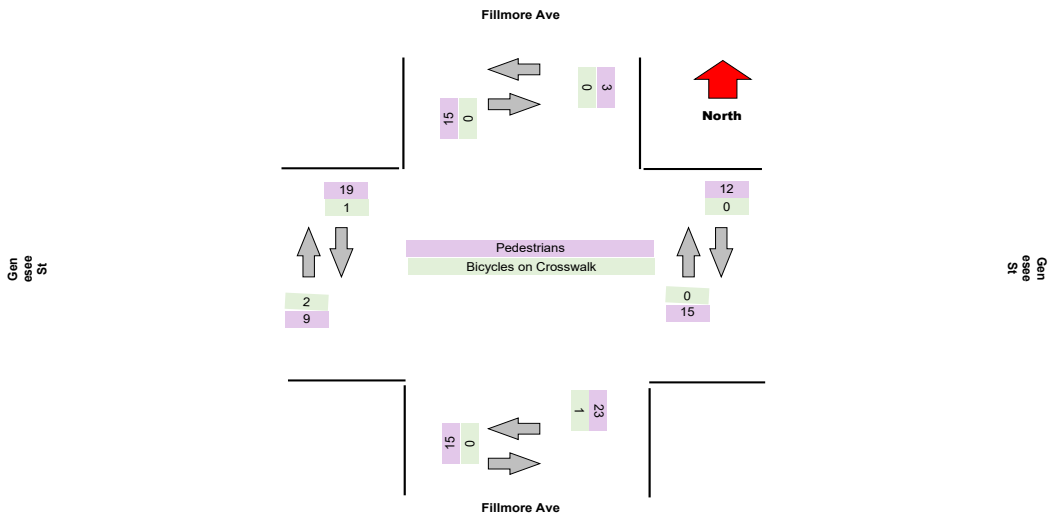
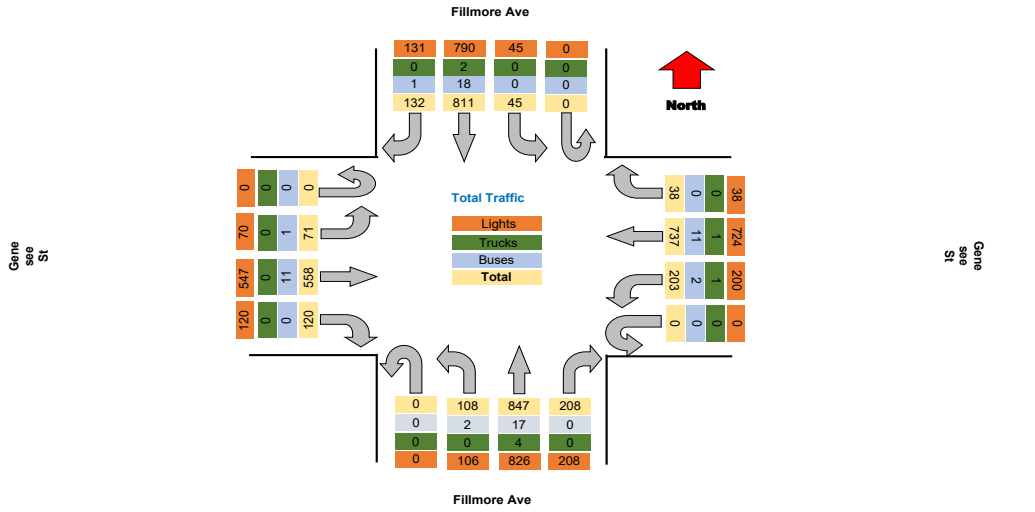

Project : VBH Malta NY
Site : Site 4
Location : 42.948550, -73.790036

TSTData.com

Survey Date : 2021-04-28, Wednesday

Turning Movement Peak Hour Data (AM)

7:30:00 AM

Leg Direction	Fillmore Ave					Genesee St					Fillmore Ave					Genesee St					Total								
	Southbound					Westbound					Northbound					Eastbound													
Start Time	Right	Thru	Left	U-Turn	App Total	Peds CW	Peds CCW	Right	Thru	Left	U-Turn	App Total	Peds CW	Peds CCW	Right	Thru	Left	U-Turn	App Total	Peds CW	Peds CCW	Total							
7:30:00 AM	2	46	1	0	49	0	0	2	46	7	0	55	1	0	6	31	5	0	43	0	0	17	0	0	164				
7:45:00 AM	5	50	0	0	55	2	0	1	48	10	0	59	1	0	13	42	6	0	62	0	0	29	0	0	206				
8:00:00 AM	4	45	1	0	50	1	0	3	45	11	0	59	2	0	8	33	7	0	50	1	0	39	0	1	198				
8:15:00 AM	9	60	1	0	70	0	0	0	44	5	0	50	0	0	6	32	5	0	43	3	1	5	23	2	0	193			
Grand Total	20	201	3	0	224	3	0	6	183	33	0	223	4	0	33	138	23	0	198	4	1	25	79	11	0	780			
% Approach	8.9%	89.7%	1.3%	0.0%	0.0%	0.0%	0.0%	2.7%	82.1%	14.8%	0.0%	0.0%	0.0%	0.0%	16.7%	69.7%	11.6%	0.0%	0.0%	0.0%	0.0%	21.7%	65.7%	9.8%	0.0%	0.0%	0.0%		
% Total	2.6%	26.4%	0.4%	0.0%	28.6%	0.0%	0.0%	0.8%	24.1%	4.3%	0.0%	29.3%	0.0%	0.0%	4.3%	18.2%	3.0%	0.0%	26.1%	0.0%	0.0%	3.3%	10.4%	1.4%	0.0%	15.1%	0.0%	0.0%	
PHF	0.556	0.838	0.750	0.000	0.800	0.000	0.000	0.500	0.953	0.750	0.000	0.945	0.000	0.000	0.635	0.821	0.821	0.000	0.798	0.000	0.000	0.481	0.859	0.550	0.000	0.737	0.000	0.000	
Lights	20	194	3	0	217	0	0	6	181	32	0	219	0	0	33	129	22	0	184	0	0	25	75	10	0	110	0	0	
% Lights	100.0%	96.5%	100.0%	0.0%	96.9%	0.0%	0.0%	100.0%	98.9%	97.0%	0.0%	98.2%	0.0%	0.0%	100.0%	93.5%	95.7%	0.0%	92.9%	0.0%	0.0%	100.0%	94.9%	90.9%	0.0%	95.7%	0.0%	0.0%	
Trucks	0	0	0	0	0	0	0	0	1	1	0	2	0	0	0	2	0	0	2	0	0	0	0	0	0	0	0	0	
% Trucks	0.0%	0.0%	0.0%	0.0%	0.0%	0.0%	0.0%	0.0%	0.5%	3.0%	0.0%	0.9%	0.0%	0.0%	0.0%	1.4%	0.0%	0.0%	1.0%	0.0%	0.0%	0.0%	0.0%	0.0%	0.0%	0.0%	0.0%	0.0%	
Buses	0	6	0	0	6	0	0	0	1	0	0	1	0	0	0	7	1	0	8	0	0	0	4	1	0	5	0	0	
% Buses	0.0%	3.0%	0.0%	0.0%	0.0%	0.0%	0.0%	0.0%	0.5%	0.0%	0.0%	0.0%	0.0%	0.0%	0.0%	5.1%	4.3%	0.0%	0.0%	0.0%	0.0%	0.0%	5.1%	9.1%	0.0%	0.0%	0.0%	0.0%	
Pedestrians	0	0	0	0	0	3	1	0	0	0	0	4	0	0	0	0	0	0	0	4	1	0	0	0	0	0	1	0	
% Pedestrians	0.0%	0.0%	0.0%	0.0%	0.0%	100.0%	100.0%	0.0%	0.0%	0.0%	0.0%	0.0%	100.0%	0.0%	0.0%	0.0%	0.0%	0.0%	0.0%	0.0%	100.0%	100.0%	0.0%	0.0%	0.0%	0.0%	0.0%	100.0%	0.0%
Bicycles on Crosswalk	0	0	0	0	0	0	0	0	0	0	0	0	0	0	0	0	0	0	0	0	0	0	0	0	0	0	0	0	
% Bicycles on Crosswalk	0.0%	0.0%	0.0%	0.0%	0.0%	0.0%	0.0%	0.0%	0.0%	0.0%	0.0%	0.0%	0.0%	0.0%	0.0%	0.0%	0.0%	0.0%	0.0%	0.0%	0.0%	0.0%	0.0%	0.0%	0.0%	0.0%	0.0%	0.0%	

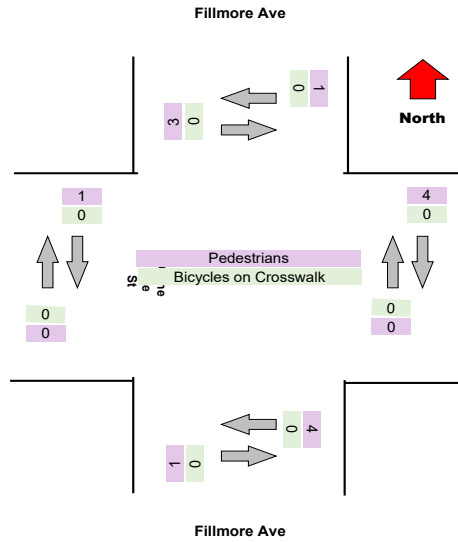
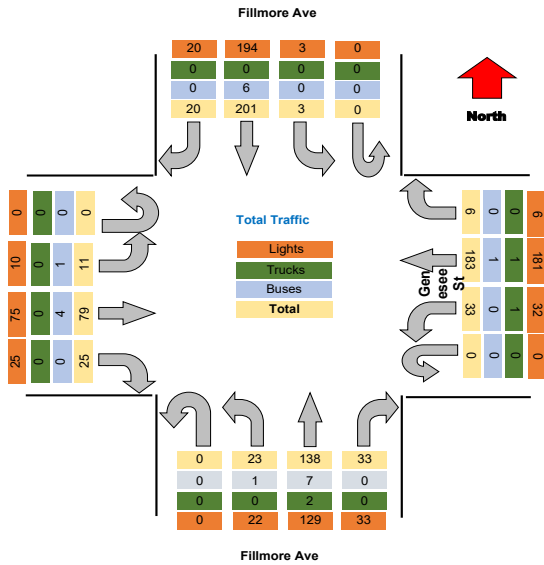

Project : VBH Malta NY
Site : Site 4
Location : 42.948550, -73.790036

TSTData.com

Survey Date : 2021-04-28, Wednesday

Turning Movement Peak Hour Data (PM)

4:15:00 PM

Leg Direction	Fillmore Ave										Genesee St										Total	
	Southbound					Westbound					Northbound					Eastbound						
	Right	Thru	Left	U-Turn	App Total	Peds CW	Peds CCW	Right	Thru	Left	U-Turn	App Total	Peds CW	Peds CCW	Right	Thru	Left	U-Turn	App Total	Peds CW		Peds CCW
4:15:00 PM	12	72	4	0	88	0	1	6	50	17	0	73	0	1	18	71	9	0	98	1	0	322
4:30:00 PM	7	71	5	0	83	1	0	5	61	14	0	80	0	1	11	87	14	0	112	1	1	351
4:45:00 PM	12	67	5	0	84	2	0	5	54	18	0	77	1	2	21	64	5	0	90	1	4	318
5:00:00 PM	11	59	3	0	73	2	0	2	60	25	0	87	0	0	23	69	9	0	121	1	2	364
Grand Total	42	269	17	0	328	5	1	18	225	74	0	317	1	4	73	311	37	0	421	4	7	1382
% Approach	12.8%	82.0%	5.2%	0.0%	0.0%	0.0%	0.0%	5.7%	71.0%	23.3%	0.0%	0.0%	0.0%	0.0%	17.3%	73.9%	8.8%	0.0%	0.0%	0.0%	0.0%	0.0%
% Total	3.1%	19.9%	1.3%	0.0%	24.3%	0.0%	0.0%	1.3%	16.6%	5.5%	0.0%	23.4%	0.0%	0.0%	5.4%	23.0%	2.7%	0.0%	31.1%	0.0%	0.0%	0.0%
PHF	0.875	0.934	0.850	0.000	0.932	0.000	0.000	0.750	0.922	0.740	0.000	0.911	0.000	0.000	0.793	0.874	0.661	0.000	0.870	0.000	0.000	0.929
Lights	41	263	17	0	321	0	0	18	223	73	0	314	0	0	73	308	37	0	418	0	0	1336
% Lights	97.6%	97.8%	100.0%	0.0%	97.9%	0.0%	0.0%	100.0%	99.1%	98.6%	0.0%	99.1%	0.0%	0.0%	100.0%	99.0%	100.0%	0.0%	99.3%	0.0%	0.0%	98.8%
Trucks	0	1	0	0	1	0	0	0	0	0	0	0	0	0	0	1	0	0	1	0	0	2
% Trucks	0.0%	0.4%	0.0%	0.0%	0.3%	0.0%	0.0%	0.0%	0.0%	0.0%	0.0%	0.0%	0.0%	0.0%	0.0%	0.3%	0.0%	0.0%	0.2%	0.0%	0.0%	0.1%
Buses	1	5	0	0	6	0	0	0	2	1	0	3	0	0	0	2	0	0	2	0	0	14
% Buses	2.4%	1.9%	0.0%	0.0%	0.0%	0.0%	0.0%	0.0%	0.9%	1.4%	0.0%	0.0%	0.0%	0.0%	0.0%	0.6%	0.0%	0.0%	0.0%	0.0%	0.0%	1.0%
Pedestrians	0	0	0	0	0	5	1	0	0	0	0	1	4	0	0	0	0	0	3	7	0	7
% Pedestrians	0.0%	0.0%	0.0%	0.0%	0.0%	100.0%	100.0%	0.0%	0.0%	0.0%	0.0%	0.0%	100.0%	100.0%	0.0%	0.0%	0.0%	0.0%	0.0%	75.0%	100.0%	0.0%
Bicycles on Crosswalk	0	0	0	0	0	0	0	0	0	0	0	0	0	0	0	0	0	0	1	0	1	0
% Bicycles on Crosswalk	0.0%	0.0%	0.0%	0.0%	0.0%	0.0%	0.0%	0.0%	0.0%	0.0%	0.0%	0.0%	0.0%	0.0%	0.0%	0.0%	0.0%	0.0%	0.0%	25.0%	0.0%	0.0%

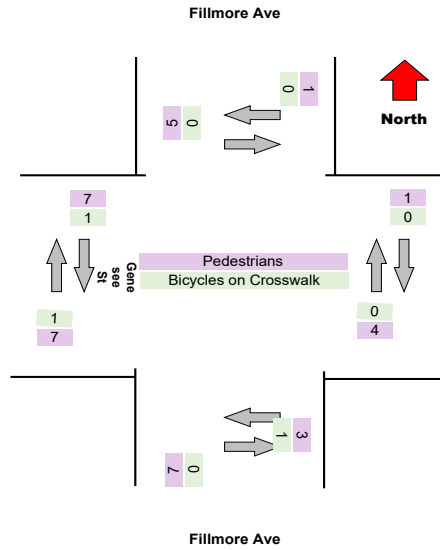
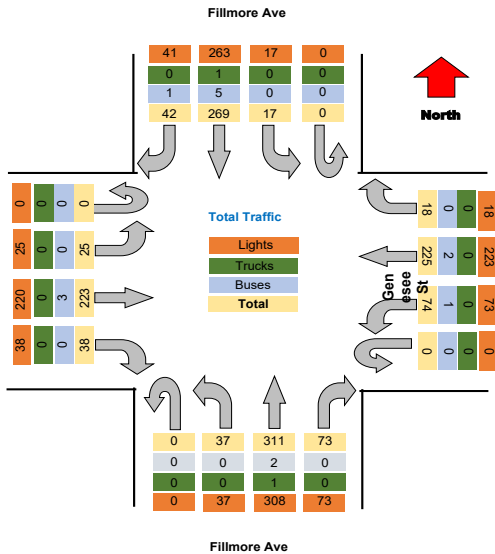

Project : VBH Malta NY
Site : Site 4
Location : 42.948550, -73.790036

TSTData.com

Survey Date : 2021-04-28, Wednesday

Project	LaBella
Project Code	LaBella
Site Name	15
Legs and Movements	All Processed Legs & Move
Bin Size	15 minutes
Survey Date	2021-11-03, Wednesday
Location	15
Latitude and Longitude	42.902329, -78.839303

	Start	End	PHF
Forced Peak AM	2021/11/03 07:30:00	2021/11/03 08:30:00	0.86
Forced Peak PM	2021/11/03 16:30:00	2021/11/03 17:30:00	0.89
AM Peak	2021/11/03 07:30:00	2021/11/03 08:30:00	0.86
PM Peak	2021/11/03 16:15:00	2021/11/03 17:15:00	0.92

Turning Movement Data

Leg Direction	Fillmore Ave										Genesee St										Total									
	Southbound					Westbound					Northbound					Eastbound														
	Right	Thru	Left	U-Turn	App Total	Peds CV	Peds CCV	Right	Thru	Left	U-Turn	App Total	Peds CV	Peds CCV	Right	Thru	Left	U-Turn	App Total	Peds CV		Peds CCV								
Start Time																														
6:30:00 AM	4	25	0	0	29	0	1	0	20	9	0	30	0	0	4	30	3	0	37	0	0	3	9	1	0	13	0	2	109	
6:45:00 AM	4	28	0	0	32	0	0	2	40	8	0	50	1	1	7	26	2	0	37	0	1	3	13	1	0	17	0	0	136	
Hourly Total	8	53	0	0	61	0	1	2	60	17	0	80	1	1	11	56	5	0	74	0	1	6	22	2	0	30	0	2	245	
7:00:00 AM	2	39	1	0	42	0	0	1	35	9	0	45	8	2	3	28	5	0	44	0	2	2	20	0	0	22	1	0	153	
7:15:00 AM	3	34	2	0	39	1	2	0	30	9	0	41	4	1	6	44	4	0	59	2	0	1	21	1	0	23	0	2	162	
7:30:00 AM	8	41	0	0	49	1	1	2	62	19	0	84	0	0	8	50	2	0	60	0	1	6	24	3	0	33	0	0	226	
7:45:00 AM	7	78	2	0	87	0	0	4	85	26	0	115	0	0	9	65	13	0	87	0	1	7	22	4	0	33	0	1	322	
Hourly Total	20	192	5	0	217	2	3	7	212	63	0	285	10	3	26	187	24	0	250	2	4	16	87	8	0	111	1	3	863	
8:00:00 AM	6	69	5	0	80	3	0	0	69	21	0	90	7	2	13	73	10	0	105	3	2	14	56	8	0	78	2	3	353	
8:15:00 AM	5	75	3	0	83	0	0	2	80	16	0	98	0	0	7	63	14	0	84	1	2	6	39	7	0	52	1	1	317	
Hourly Total	11	144	8	0	163	3	0	2	149	37	0	188	7	2	20	136	24	0	189	4	4	20	95	15	0	130	3	4	670	
4:00:00 PM	9	79	6	0	94	1	1	0	64	18	0	82	1	2	16	66	13	0	95	3	2	8	74	12	0	94	0	10	365	
4:15:00 PM	8	74	3	0	85	0	1	3	60	23	0	86	2	5	20	78	8	0	106	0	5	9	69	7	0	85	2	2	362	
4:30:00 PM	14	81	3	0	98	0	0	5	77	15	0	97	2	1	23	97	5	0	125	2	1	14	75	7	0	96	0	2	416	
4:45:00 PM	20	85	8	0	113	4	0	4	67	17	0	88	2	4	14	94	8	0	114	1	0	13	66	10	0	89	1	4	404	
Hourly Total	51	319	20	0	390	5	2	12	268	73	0	353	7	12	73	335	32	0	440	6	8	44	284	36	0	354	3	18	1547	
5:00:00 PM	9	69	4	0	82	1	0	3	58	16	0	77	3	1	22	75	5	0	102	1	2	12	65	11	0	88	1	1	349	
5:15:00 PM	14	67	3	0	84	3	0	4	68	12	0	84	1	0	20	57	4	0	81	1	1	4	63	3	0	70	1	4	319	
5:30:00 PM	7	77	7	0	91	0	1	6	56	23	0	85	1	2	12	71	3	1	87	2	2	11	56	6	0	73	0	3	336	
5:45:00 PM	14	59	8	0	81	0	0	2	53	28	0	83	0	0	14	59	9	1	83	1	2	10	39	8	0	57	0	2	304	
Hourly Total	44	272	22	0	338	4	4	15	235	79	0	329	5	3	68	262	21	2	353	5	7	37	223	28	0	288	2	10	1308	
Grand Total	134	980	55	0	1169	14	10	38	924	269	0	1235	30	21	198	978	105	2	1306	17	24	123	711	89	0	923	5	37	4633	
% Approach	11.5%	83.8%	4.7%	0.0%	0.0%	0.0%	0.0%	3.1%	74.8%	21.8%	0.0%	0.0%	0.0%	0.0%	15.2%	74.7%	8.1%	0.2%	0.0%	0.0%	0.0%	13.3%	77.0%	9.6%	0.0%	0.0%	0.0%	0.0%	0.0%	
% Total	2.9%	21.2%	1.2%	0.0%	25.2%	0.0%	0.0%	0.8%	19.9%	5.8%	0.0%	26.7%	0.0%	0.0%	4.3%	21.1%	2.3%	0.0%	28.2%	0.0%	0.0%	2.7%	15.3%	1.9%	0.0%	19.9%	0.0%	0.0%	0.0%	
Lights	130	930	53	0	1113	0	0	34	893	251	0	1178	0	0	195	942	98	2	1237	0	0	113	675	85	0	873	0	0	4401	
% Lights	97.0%	94.9%	98.4%	0.0%	95.2%	0.0%	0.0%	89.9%	96.6%	93.3%	0.0%	95.4%	0.0%	0.0%	85.5%	96.5%	92.5%	100.0%	94.7%	0.0%	0.0%	91.9%	94.8%	95.5%	0.0%	94.6%	0.0%	0.0%	95.0%	
Trucks	0	2	0	0	2	0	0	0	3	2	0	5	0	0	0	2	0	0	2	0	0	0	0	0	0	0	0	0	0	9
% Trucks	0.0%	0.2%	0.0%	0.0%	0.2%	0.0%	0.0%	0.0%	0.3%	0.7%	0.0%	0.4%	0.0%	0.0%	0.0%	0.2%	0.0%	0.0%	0.2%	0.0%	0.0%	0.0%	0.0%	0.0%	0.0%	0.0%	0.0%	0.0%	0.2%	
Buses	4	47	2	0	53	0	0	4	25	16	0	45	0	0	3	32	8	0	43	0	0	10	36	4	0	50	0	0	191	
% Buses	3.0%	4.8%	3.6%	0.0%	0.0%	0.0%	0.0%	0.0%	2.7%	5.9%	0.0%	0.0%	0.0%	0.0%	1.5%	3.3%	7.5%	0.0%	0.0%	0.0%	0.0%	8.1%	5.1%	4.5%	0.0%	0.0%	0.0%	0.0%	4.1%	
Pedestrians	0	0	0	0	0	14	10	0	0	0	0	0	30	21	0	0	0	0	0	16	23	0	0	0	0	0	0	9	36	0
% Pedestrians	0.0%	0.0%	0.0%	0.0%	0.0%	100.0%	100.0%	0.0%	0.0%	0.0%	0.0%	0.0%	100.0%	100.0%	0.0%	0.0%	0.0%	0.0%	0.0%	0.0%	0.0%	0.0%	0.0%	0.0%	0.0%	0.0%	0.0%	100.0%	87.3%	0.0%
Bicycles on Crosswalk	0	0	0	0	0	0	0	0	0	0	0	0	0	0	0	0	0	0	1	1	0	0	0	0	0	0	0	0	1	0
% Bicycles on Crosswalk	0.0%	0.0%	0.0%	0.0%	0.0%	0.0%	0.0%	0.0%	0.0%	0.0%	0.0%	0.0%	0.0%	0.0%	0.0%	0.0%	0.0%	0.0%	0.0%	0.0%	0.0%	0.0%	0.0%	0.0%	0.0%	0.0%	0.0%	0.0%	2.7%	0.0%

Turning Movement Data Plot

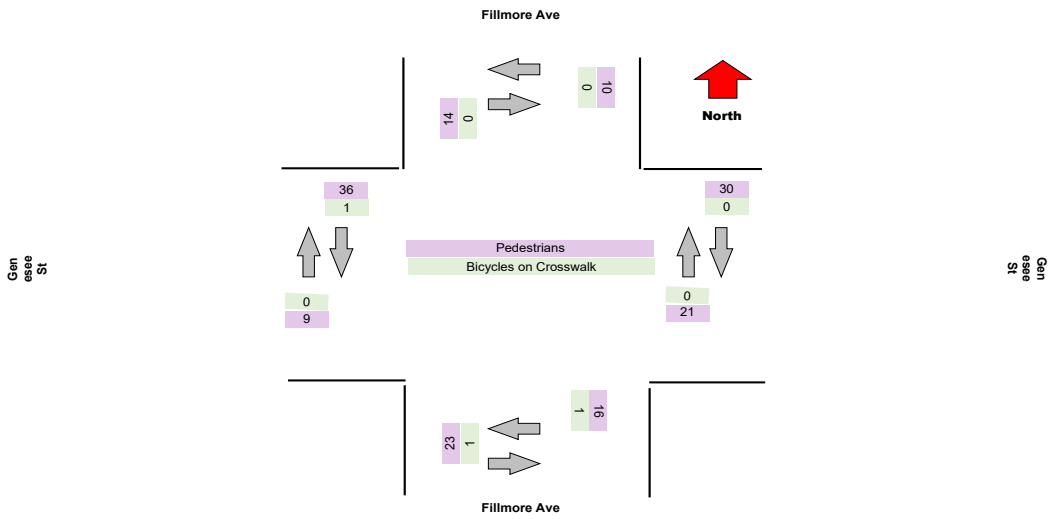
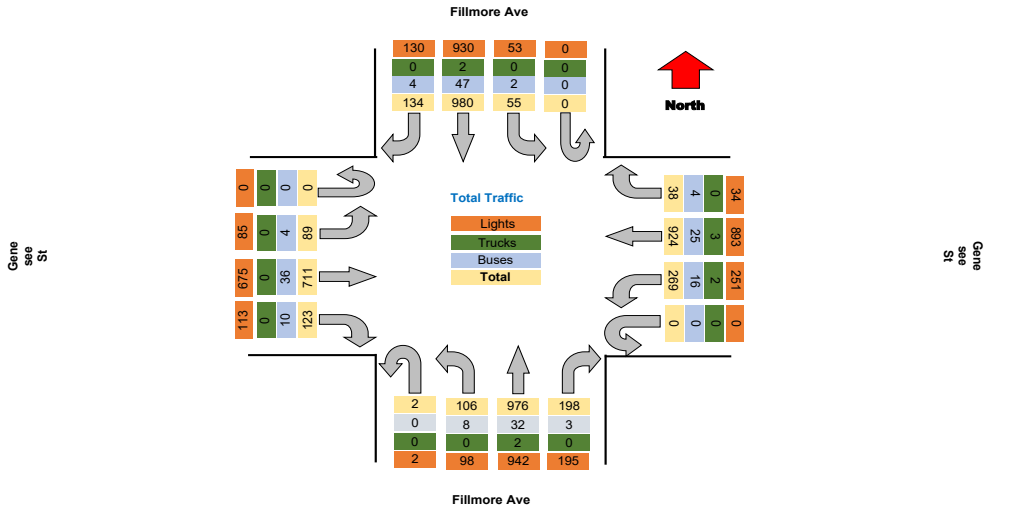

Turning Movement Peak Hour Data (AM)

7:30:00 AM

Leg Direction	Fillmore Ave						Genesee St						Fillmore Ave						Genesee St						Total				
	Southbound			Northbound			Westbound			Eastbound			Northbound			Eastbound													
Start Time	Right	Thru	Left	U-Turn	App Total	Peds CW	Peds CCW	Right	Thru	Left	U-Turn	App Total	Peds CW	Peds CCW	Right	Thru	Left	U-Turn	App Total	Peds CW	Peds CCW	Total							
7:30:00 AM	8	41	0	0	49	1	1	2	62	19	0	84	0	0	8	50	2	0	60	0	1	6	24	3	0	33	0	0	226
7:45:00 AM	7	78	2	0	87	0	0	4	85	26	0	115	0	0	9	65	13	0	87	0	1	7	22	4	0	33	0	1	322
8:00:00 AM	6	69	5	0	80	3	0	0	69	21	0	90	7	2	13	73	10	0	105	3	2	14	56	8	0	78	2	3	353
8:15:00 AM	5	75	3	0	83	0	0	2	69	16	0	88	0	0	7	63	14	0	84	1	2	6	39	7	0	52	1	1	317
Grand Total	26	263	10	0	299	4	1	8	296	82	0	387	7	2	37	251	39	0	336	4	6	33	141	22	0	196	3	5	1218
% Approach	8.7%	88.0%	3.3%	0.0%	0.0%	0.0%	0.0%	2.1%	76.5%	21.2%	0.0%	0.0%	0.0%	0.0%	11.0%	74.7%	11.6%	0.0%	0.0%	0.0%	0.0%	16.8%	71.9%	11.2%	0.0%	0.0%	0.0%	0.0%	0.0%
% Total	2.1%	21.6%	0.8%	0.0%	24.5%	0.0%	0.0%	0.7%	24.3%	6.7%	0.0%	31.8%	0.0%	0.0%	3.0%	20.6%	3.2%	0.0%	27.6%	0.0%	0.0%	2.7%	11.6%	1.8%	0.0%	16.1%	0.0%	0.0%	0.863
PHF	0.813	0.843	0.500	0.000	0.859	0.000	0.000	0.500	0.871	0.788	0.000	0.841	0.000	0.000	0.712	0.860	0.696	0.000	0.800	0.000	0.000	0.589	0.629	0.688	0.000	0.628	0.000	0.000	0.863
Lights	25	246	10	0	281	0	0	6	289	71	0	366	0	0	36	238	36	0	310	0	0	29	129	21	0	179	0	0	1136
% Lights	86.2%	93.5%	100.0%	0.0%	94.0%	0.0%	0.0%	75.0%	97.6%	86.6%	0.0%	94.6%	0.0%	0.0%	87.3%	94.8%	92.3%	0.0%	92.3%	0.0%	0.0%	87.9%	91.5%	95.5%	0.0%	91.3%	0.0%	0.0%	93.3%
Trucks	0	0	0	0	0	0	0	0	2	2	0	4	0	0	0	0	0	0	0	0	0	0	0	0	0	0	0	0	4
% Trucks	0.0%	0.0%	0.0%	0.0%	0.0%	0.0%	0.0%	0.0%	0.7%	2.4%	0.0%	1.0%	0.0%	0.0%	0.0%	0.0%	0.0%	0.0%	0.0%	0.0%	0.0%	0.0%	0.0%	0.0%	0.0%	0.0%	0.0%	0.0%	0.3%
Buses	1	16	0	0	17	0	0	2	5	9	0	16	0	0	1	13	3	0	17	0	0	4	12	1	0	17	0	0	67
% Buses	3.8%	6.1%	0.0%	0.0%	0.0%	0.0%	0.0%	25.0%	1.7%	11.0%	0.0%	0.0%	0.0%	0.0%	2.7%	5.2%	7.7%	0.0%	0.0%	0.0%	0.0%	12.1%	8.5%	4.5%	0.0%	0.0%	0.0%	5.5%	
Pedestrians	0	0	0	0	0	4	1	0	0	0	0	7	2	0	0	0	0	0	0	4	6	0	0	0	0	0	3	5	0
% Pedestrians	0.0%	0.0%	0.0%	0.0%	0.0%	100.0%	100.0%	0.0%	0.0%	0.0%	0.0%	0.0%	100.0%	100.0%	0.0%	0.0%	0.0%	0.0%	0.0%	0.0%	100.0%	100.0%	0.0%	0.0%	0.0%	0.0%	0.0%	100.0%	100.0%
Bicycles on Crosswalk	0	0	0	0	0	0	0	0	0	0	0	0	0	0	0	0	0	0	0	0	0	0	0	0	0	0	0	0	0
% Bicycles on Crosswalk	0.0%	0.0%	0.0%	0.0%	0.0%	0.0%	0.0%	0.0%	0.0%	0.0%	0.0%	0.0%	0.0%	0.0%	0.0%	0.0%	0.0%	0.0%	0.0%	0.0%	0.0%	0.0%	0.0%	0.0%	0.0%	0.0%	0.0%	0.0%	0.0%

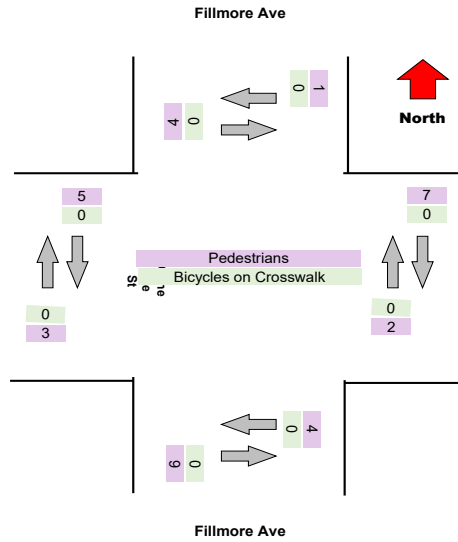
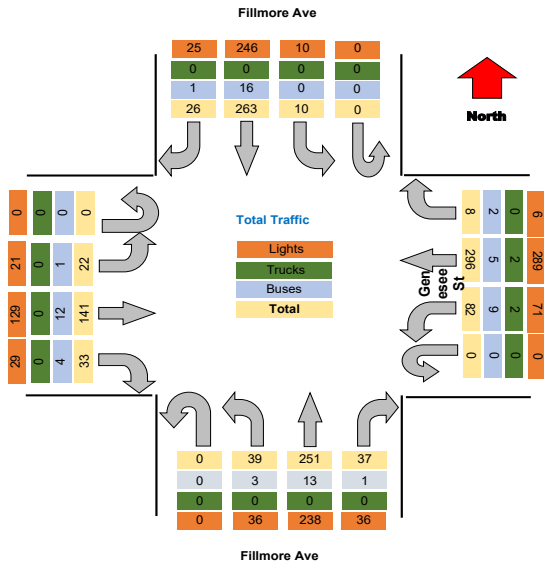

Project : VBH Malta NY
Site : Site 4
Location : 42.948550, -73.790036

TSTData.com

Survey Date : 2021-04-28, Wednesday

Turning Movement Peak Hour Data (PM)

4:15:00 PM

Leg Direction	Fillmore Ave				Genesee St				Fillmore Ave				Genesee St				Total				
	Southbound				Westbound				Northbound				Eastbound								
Start Time	Right	Thru	Left	U-Turn	App Total	Peds CW	Peds CCW	Right	Thru	Left	U-Turn	App Total	Peds CW	Peds CCW	Right	Thru	Left	U-Turn	App Total	Peds CW	Peds CCW
4:15:00 PM	8	74	3	0	85	0	1	3	60	23	0	86	2	5	20	78	8	0	106	0	5
4:30:00 PM	14	81	3	0	98	0	0	5	77	15	0	97	2	1	23	97	5	0	125	2	1
4:45:00 PM	20	85	8	0	113	4	0	4	67	17	0	88	2	4	14	94	6	0	114	1	0
5:00:00 PM	9	69	4	0	82	1	0	3	58	16	0	77	3	1	22	75	5	0	102	1	2
Grand Total	51	309	18	0	378	5	1	15	262	71	0	348	8	11	75	344	24	0	447	4	8
% Approach	13.5%	81.7%	4.8%	0.0%	0.0%	0.0%	0.0%	4.3%	75.3%	20.4%	0.0%	0.0%	0.0%	0.0%	17.7%	77.0%	5.4%	0.0%	0.0%	0.0%	0.0%
% Total	3.3%	20.2%	1.2%	0.0%	24.7%	0.0%	0.0%	1.0%	17.1%	4.6%	0.0%	22.7%	0.0%	0.0%	5.2%	22.5%	1.6%	0.0%	29.2%	0.0%	0.0%
PHF	0.638	0.909	0.563	0.000	0.836	0.000	0.000	0.750	0.851	0.772	0.000	0.897	0.000	0.000	0.859	0.887	0.750	0.000	0.894	0.000	0.000
Lights	48	296	18	0	362	0	0	13	251	68	0	332	0	0	77	339	23	0	439	0	0
% Lights	84.1%	95.8%	100.0%	0.0%	95.8%	0.0%	0.0%	86.7%	95.8%	95.8%	0.0%	95.4%	0.0%	0.0%	87.5%	98.5%	95.8%	0.0%	98.2%	0.0%	0.0%
Trucks	0	2	0	0	2	0	0	0	0	0	0	0	0	0	0	1	0	0	1	0	0
% Trucks	0.0%	0.6%	0.0%	0.0%	0.5%	0.0%	0.0%	0.0%	0.0%	0.0%	0.0%	0.0%	0.0%	0.0%	0.0%	0.3%	0.0%	0.0%	0.2%	0.0%	0.0%
Buses	3	11	0	0	14	0	0	2	8	3	0	13	0	0	2	4	1	0	7	0	0
% Buses	5.9%	3.6%	0.0%	0.0%	0.0%	0.0%	0.0%	13.3%	3.1%	4.2%	0.0%	0.0%	0.0%	0.0%	2.5%	1.2%	4.2%	0.0%	0.0%	0.0%	0.0%
Pedestrians	0	0	0	0	0	5	4	0	0	0	0	0	9	11	0	0	0	0	0	4	8
% Pedestrians	0.0%	0.0%	0.0%	0.0%	0.0%	100.0%	100.0%	0.0%	0.0%	0.0%	0.0%	0.0%	100.0%	100.0%	0.0%	0.0%	0.0%	0.0%	0.0%	0.0%	88.9%
Bicycles on Crosswalk	0	0	0	0	0	0	0	0	0	0	0	0	0	0	0	0	0	0	1	0	0
% Bicycles on Crosswalk	0.0%	0.0%	0.0%	0.0%	0.0%	0.0%	0.0%	0.0%	0.0%	0.0%	0.0%	0.0%	0.0%	0.0%	0.0%	0.0%	0.0%	0.0%	0.0%	0.0%	11.1%

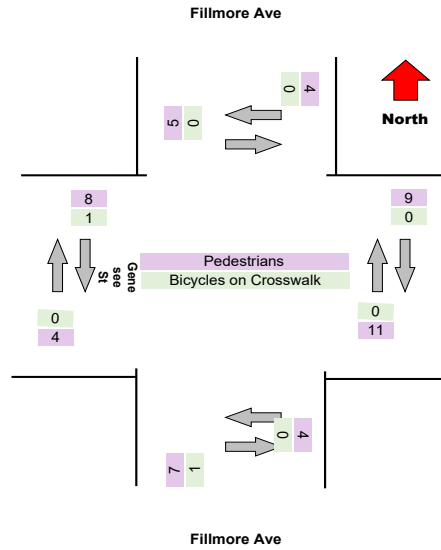
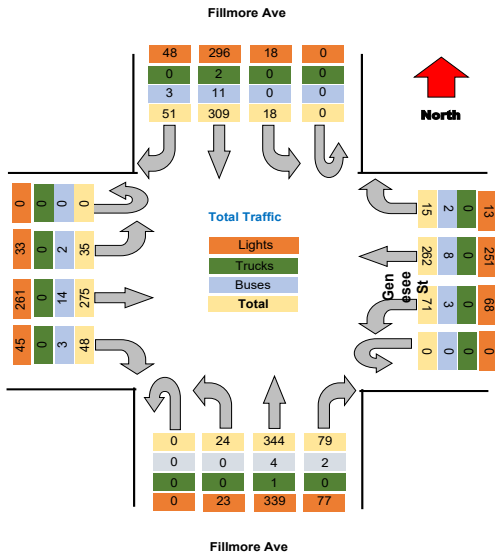

Project : VBH Malta NY
 Site : Site 4
 Location : 42.948550, -73.790036

TSTData.com

Survey Date : 2021-04-28, Wednesday

Project	LaBella
Project Code	LaBella
Site Name	15
Legs and Movements	All Processed Legs & Move
Bin Size	15 minutes
Survey Date	2021-11-04, Thursday
Location	15
Latitude and Longitude	42.902329, -78.839303

	Start	End	PHF
Forced Peak AM	2021/11/04 07:30:00	2021/11/04 08:30:00	0.87
Forced Peak PM	2021/11/04 16:30:00	2021/11/04 17:30:00	0.95
AM Peak	2021/11/04 07:30:00	2021/11/04 08:30:00	0.87
PM Peak	2021/11/04 16:15:00	2021/11/04 17:15:00	0.95

Turning Movement Data

Leg Direction	Fillmore Ave										Genesee St										Total									
	Southbound					Westbound					Northbound					Eastbound														
	Right	Thru	Left	U-Turn	App Total	Peds CV	Peds CCV	Right	Thru	Left	U-Turn	App Total	Peds CV	Peds CCV	Right	Thru	Left	U-Turn	App Total	Peds CV		Peds CCV								
Start Time																														
6:30:00 AM	1	24	0	0	25	0	1	0	26	6	0	33	0	0	6	19	3	0	28	0	2	5	7	3	0	15	1	2	101	
6:45:00 AM	2	40	2	0	44	0	0	0	44	4	0	48	0	1	2	17	5	0	25	0	0	3	16	1	0	20	0	0	137	
Hourly Total	3	64	2	0	69	0	1	0	70	10	0	81	0	1	8	36	8	0	53	0	2	5	23	4	0	35	1	2	238	
7:00:00 AM	2	32	1	0	35	0	0	0	37	10	0	37	8	0	6	35	2	0	49	0	2	2	20	0	0	22	0	0	143	
7:15:00 AM	0	32	1	0	33	0	2	0	43	4	0	49	6	2	4	35	5	0	52	1	0	2	20	1	0	23	0	3	167	
7:30:00 AM	10	44	1	0	55	1	0	1	70	19	0	90	0	0	4	46	1	0	51	0	1	8	29	2	0	39	1	0	235	
7:45:00 AM	5	71	1	0	77	0	0	3	82	23	0	118	0	1	12	55	8	0	76	0	0	6	31	7	0	44	0	0	315	
Hourly Total	17	179	4	0	200	1	2	4	232	56	0	294	12	3	26	171	16	0	228	1	3	18	100	10	0	128	1	3	850	
8:00:00 AM	13	84	3	0	100	3	1	0	59	19	0	79	2	3	19	59	10	0	93	1	5	5	50	9	0	64	2	2	336	
8:15:00 AM	6	72	3	0	81	0	1	0	55	14	0	70	0	0	9	55	9	0	73	2	0	8	37	8	0	53	0	1	277	
Hourly Total	19	156	6	0	181	3	2	0	114	33	0	149	2	3	28	114	19	0	166	3	5	13	87	17	0	117	2	3	613	
4:00:00 PM	6	92	2	0	100	2	4	3	58	18	0	79	3	4	19	76	13	0	108	1	1	19	81	15	0	115	0	6	402	
4:15:00 PM	10	78	6	0	94	1	2	6	84	11	0	101	0	2	15	79	17	0	111	2	2	18	74	5	0	97	0	3	403	
4:30:00 PM	14	77	1	0	92	2	1	4	86	17	0	97	1	0	14	93	6	0	113	0	2	11	62	7	0	100	1	2	392	
4:45:00 PM	12	86	3	0	101	0	1	5	60	13	0	78	0	0	20	70	7	0	97	3	3	14	74	7	0	95	3	3	371	
Hourly Total	42	333	12	0	387	5	8	18	268	59	0	345	4	6	68	318	43	0	429	6	8	62	311	34	0	497	4	16	1568	
5:00:00 PM	10	87	5	0	102	0	1	10	69	24	0	103	2	1	20	84	6	0	110	1	0	6	61	9	0	78	1	4	363	
5:15:00 PM	11	62	6	0	79	1	0	7	74	18	0	99	2	0	16	72	6	0	94	2	0	9	71	5	0	85	0	0	357	
5:30:00 PM	7	77	6	0	90	0	1	4	51	19	0	74	3	2	22	60	6	0	88	1	2	8	64	5	0	77	1	1	329	
5:45:00 PM	17	64	6	0	87	1	2	5	69	12	0	86	1	0	16	70	10	0	86	2	2	14	47	8	0	69	0	2	338	
Hourly Total	45	260	23	0	328	2	4	26	263	73	0	362	8	3	74	286	28	0	388	6	4	39	243	27	0	309	2	7	1387	
Grand Total	126	992	47	0	1165	11	17	48	947	231	0	1231	26	16	204	925	114	0	1284	16	25	140	764	92	0	996	10	31	4656	
% Approach	10.8%	85.2%	4.0%	0.0%	0.0%	0.0%	0.0%	3.9%	76.9%	18.8%	0.0%	0.0%	0.0%	0.0%	16.1%	73.2%	9.0%	0.0%	0.0%	0.0%	0.0%	14.1%	76.7%	9.2%	0.0%	0.0%	0.0%	0.0%	0.0%	
% Total	2.7%	21.3%	1.0%	0.0%	25.0%	0.0%	0.0%	1.0%	20.3%	5.0%	0.0%	26.4%	0.0%	0.0%	4.4%	19.9%	2.4%	0.0%	27.1%	0.0%	0.0%	3.0%	16.4%	2.0%	0.0%	21.4%	0.0%	0.0%	0.0%	
Lights	123	944	45	0	1112	0	0	46	919	215	0	1160	0	0	196	878	105	0	1179	0	0	130	724	87	0	941	0	0	4412	
% Lights	97.6%	95.2%	95.7%	0.0%	95.5%	0.0%	0.0%	95.9%	97.0%	93.1%	0.0%	95.9%	0.0%	0.0%	96.1%	94.9%	92.1%	0.0%	93.3%	0.0%	0.0%	92.9%	94.8%	94.6%	0.0%	94.5%	0.0%	0.0%	94.8%	
Trucks	0	5	0	0	5	0	0	0	1	0	0	1	0	0	1	7	0	0	8	0	0	0	4	0	0	4	0	0	15	
% Trucks	0.0%	0.5%	0.0%	0.0%	0.4%	0.0%	0.0%	0.0%	0.1%	0.0%	0.0%	0.1%	0.0%	0.0%	0.5%	0.8%	0.0%	0.0%	0.6%	0.0%	0.0%	0.0%	0.5%	0.0%	0.0%	0.4%	0.0%	0.0%	0.4%	
Buses	3	43	2	0	48	0	0	2	27	16	0	45	0	0	7	40	9	0	56	0	0	9	36	5	0	50	0	0	199	
% Buses	2.4%	4.3%	4.3%	0.0%	0.0%	0.0%	0.0%	0.0%	2.9%	6.9%	0.0%	0.0%	0.0%	0.0%	3.4%	4.3%	7.9%	0.0%	0.0%	0.0%	0.0%	6.4%	4.7%	5.4%	0.0%	0.0%	0.0%	0.0%	4.3%	
Pedestrians	0	0	0	0	0	10	16	0	0	0	0	0	26	16	0	0	0	0	0	16	22	0	0	0	0	0	0	9	30	0
% Pedestrians	0.0%	0.0%	0.0%	0.0%	0.0%	89.8%	84.1%	0.0%	0.0%	0.0%	0.0%	0.0%	100.0%	100.0%	0.0%	0.0%	0.0%	0.0%	0.0%	100.0%	100.0%	0.0%	0.0%	0.0%	0.0%	0.0%	0.0%	80.0%	86.8%	0.0%
Bicycles on Crosswalk	0	0	0	0	0	1	1	0	0	0	0	0	0	0	0	0	0	0	0	0	0	0	0	0	0	0	1	1	0	
% Bicycles on Crosswalk	0.0%	0.0%	0.0%	0.0%	0.0%	9.1%	5.9%	0.0%	0.0%	0.0%	0.0%	0.0%	0.0%	0.0%	0.0%	0.0%	0.0%	0.0%	0.0%	0.0%	0.0%	0.0%	0.0%	0.0%	0.0%	0.0%	0.0%	10.0%	5.2%	0.0%

Turning Movement Data Plot

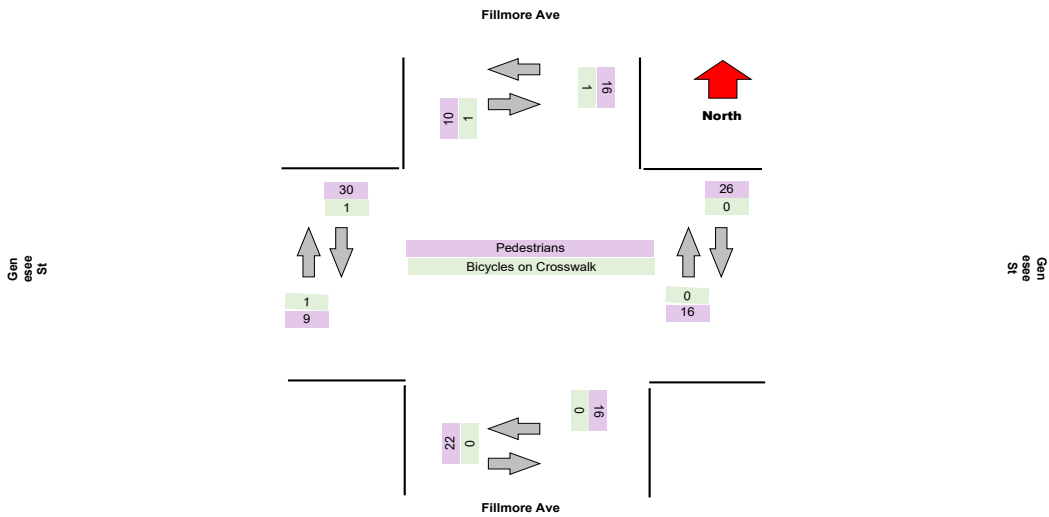
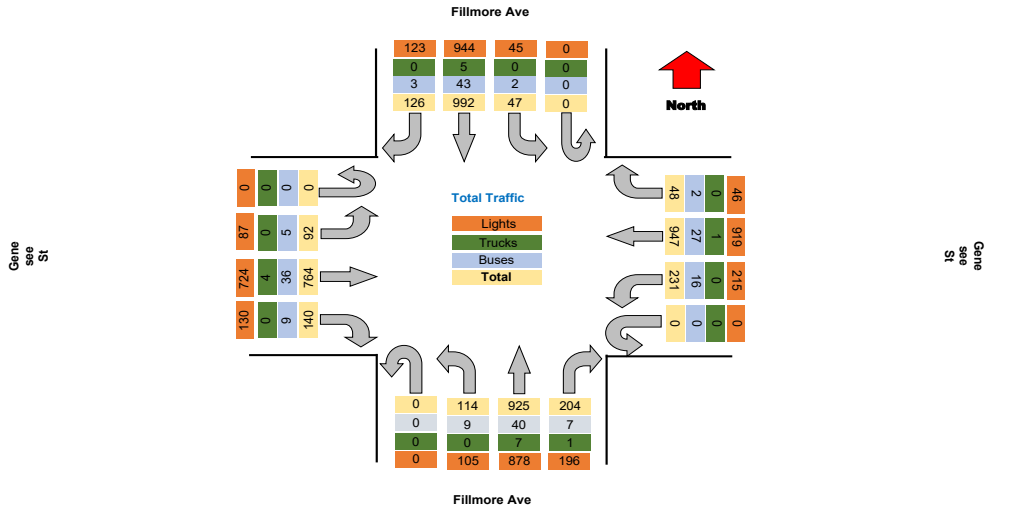

Project : VBH Malta NY
Site : Site 4
Location : 42.948550, -73.790036
Survey Date : 2021-04-28, Wednesday

TSTData.com

Turning Movement Peak Hour Data (AM)

7:30:00 AM

Leg Direction	Fillmore Ave						Genesee St						Fillmore Ave						Genesee St						Total				
	Southbound			Northbound			Westbound			Eastbound			Northbound			Eastbound													
Start Time	Right	Thru	Left	U-Turn	App Total	Peds CW	Peds CCW	Right	Thru	Left	U-Turn	App Total	Peds CW	Peds CCW	Right	Thru	Left	U-Turn	App Total	Peds CW	Peds CCW	Right	Thru	Left	U-Turn	App Total	Peds CW	Peds CCW	
7:30:00 AM	10	44	1	0	55	1	0	1	70	19	0	90	0	0	4	46	1	0	51	0	1	8	29	2	0	39	1	0	235
7:45:00 AM	5	71	1	0	77	0	0	3	92	23	0	118	0	1	12	55	8	0	76	0	0	6	31	7	0	44	0	0	316
8:00:00 AM	13	84	3	0	100	3	1	0	59	19	0	79	2	3	19	59	10	0	93	1	5	5	50	9	0	64	2	2	336
8:15:00 AM	6	72	3	0	81	0	0	0	55	14	0	70	0	0	9	55	9	0	73	2	0	8	37	8	0	53	0	1	277
Grand Total	34	271	8	0	313	4	1	4	276	75	0	357	2	4	44	215	28	0	293	3	6	27	147	29	0	299	3	3	1163
% Approach	10.9%	86.6%	2.6%	0.0%	0.0%	0.0%	0.0%	1.1%	77.3%	21.0%	0.0%	0.0%	0.0%	0.0%	15.0%	73.4%	9.6%	0.0%	0.0%	0.0%	0.0%	13.5%	73.5%	13.0%	0.0%	0.0%	0.0%	0.0%	0.0%
% Total	2.9%	23.3%	0.7%	0.0%	26.9%	0.0%	0.0%	0.3%	23.7%	6.4%	0.0%	30.7%	0.0%	0.0%	3.8%	18.5%	2.4%	0.0%	25.2%	0.0%	0.0%	2.3%	12.6%	2.2%	0.0%	17.2%	0.0%	0.0%	0.0%
PHF	0.654	0.807	0.667	0.000	0.783	0.000	0.000	0.333	0.750	0.815	0.000	0.756	0.000	0.000	0.579	0.911	0.700	0.000	0.788	0.000	0.000	0.844	0.735	0.722	0.000	0.781	0.000	0.000	0.865
Lights	33	255	7	0	295	0	0	3	270	67	0	340	0	0	39	198	25	0	262	0	0	23	135	24	0	182	0	0	1079
% Lights	87.1%	94.1%	87.5%	0.0%	94.2%	0.0%	0.0%	75.0%	97.8%	89.3%	0.0%	95.2%	0.0%	0.0%	88.6%	92.1%	89.3%	0.0%	89.4%	0.0%	0.0%	85.2%	91.8%	92.3%	0.0%	91.0%	0.0%	0.0%	92.8%
Trucks	0	1	0	0	1	0	0	0	0	0	0	0	0	0	1	1	0	0	2	0	0	0	3	0	0	3	0	0	6
% Trucks	0.0%	0.4%	0.0%	0.0%	0.3%	0.0%	0.0%	0.0%	0.0%	0.0%	0.0%	0.0%	0.0%	0.0%	2.3%	0.5%	0.0%	0.0%	0.7%	0.0%	0.0%	0.0%	2.0%	0.0%	0.0%	1.5%	0.0%	0.0%	0.5%
Buses	1	15	1	0	17	0	0	1	6	8	0	15	0	0	4	16	3	0	23	0	0	4	9	2	0	15	0	0	70
% Buses	2.9%	5.5%	12.5%	0.0%	0.0%	0.0%	0.0%	25.0%	2.2%	10.7%	0.0%	0.0%	0.0%	0.0%	9.1%	7.4%	10.7%	0.0%	0.0%	0.0%	0.0%	14.8%	6.1%	7.7%	0.0%	0.0%	0.0%	0.0%	6.0%
Pedestrians	0	0	0	0	0	4	2	0	0	0	0	2	4	0	0	0	0	0	0	3	6	0	0	0	0	0	3	3	0
% Pedestrians	0.0%	0.0%	0.0%	0.0%	0.0%	100.0%	100.0%	0.0%	0.0%	0.0%	0.0%	0.0%	100.0%	100.0%	0.0%	0.0%	0.0%	0.0%	0.0%	0.0%	100.0%	100.0%	0.0%	0.0%	0.0%	0.0%	0.0%	100.0%	0.0%
Bicycles on Crosswalk	0	0	0	0	0	0	0	0	0	0	0	0	0	0	0	0	0	0	0	0	0	0	0	0	0	0	0	0	0
% Bicycles on Crosswalk	0.0%	0.0%	0.0%	0.0%	0.0%	0.0%	0.0%	0.0%	0.0%	0.0%	0.0%	0.0%	0.0%	0.0%	0.0%	0.0%	0.0%	0.0%	0.0%	0.0%	0.0%	0.0%	0.0%	0.0%	0.0%	0.0%	0.0%	0.0%	0.0%

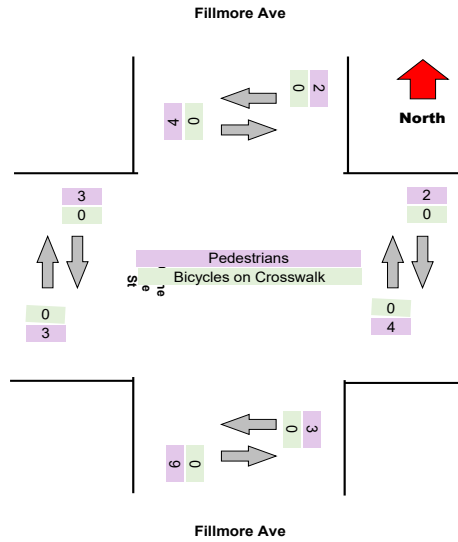
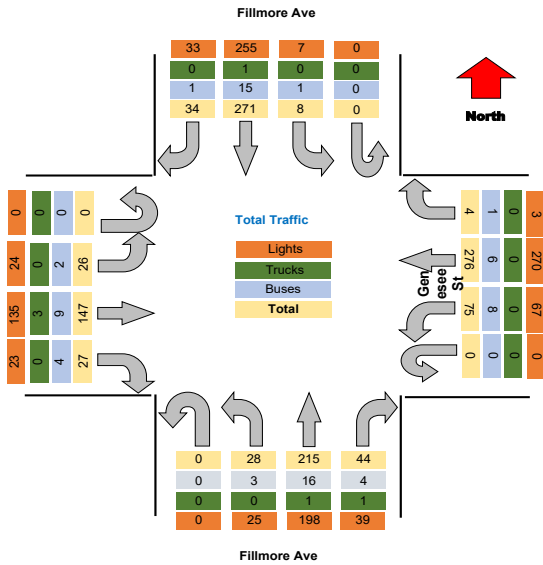

Turning Movement Peak Hour Data (PM)

4:15:00 PM

Leg Direction	Fillmore Ave										Genesee St										Total									
	Southbound					Westbound					Northbound					Eastbound														
	Right	Thru	Left	U-Turn	App Total	Peds CW	Peds CCW	Right	Thru	Left	U-Turn	App Total	Peds CW	Peds CCW	Right	Thru	Left	U-Turn	App Total	Peds CW		Peds CCW								
4:15:00 PM	10	78	6	0	94	1	2	6	84	11	0	101	0	2	15	79	17	0	111	2	2	18	74	5	0	97	0	3	403	
4:30:00 PM	14	77	1	0	92	2	1	4	66	17	0	87	1	0	14	93	6	0	113	0	2	11	82	7	0	100	1	2	392	
4:45:00 PM	12	86	3	0	101	0	1	5	60	13	0	78	0	0	20	70	7	0	97	3	3	14	74	7	0	95	3	3	371	
5:00:00 PM	10	57	5	0	72	0	1	10	69	24	0	103	2	1	20	84	6	0	110	1	0	8	61	9	0	78	1	4	363	
Grand Total	46	288	15	0	349	3	6	25	279	85	0	359	3	3	69	336	36	0	431	6	7	51	251	29	0	370	3	12	1529	
% Approach	12.8%	83.0%	4.2%	0.0%	0.0%	0.0%	0.0%	6.8%	75.6%	17.6%	0.0%	0.0%	0.0%	0.0%	16.0%	75.6%	8.4%	0.0%	0.0%	0.0%	0.0%	13.8%	75.6%	7.6%	0.0%	0.0%	0.0%	0.0%	0.0%	
% Total	3.0%	19.5%	1.0%	0.0%	23.5%	0.0%	0.0%	1.6%	18.2%	4.3%	0.0%	24.1%	0.0%	0.0%	4.5%	21.3%	2.4%	0.0%	28.2%	0.0%	0.0%	3.3%	19.0%	1.8%	0.0%	24.2%	0.0%	0.0%	0.0%	
PHF	0.821	0.866	0.625	0.000	0.889	0.000	0.000	0.625	0.830	0.677	0.000	0.896	0.000	0.000	0.863	0.876	0.529	0.000	0.854	0.000	0.000	0.708	0.887	0.778	0.000	0.925	0.000	0.000	0.949	
Lights	44	285	15	0	344	0	0	24	273	60	0	357	0	0	66	314	35	0	415	0	0	48	278	27	0	353	0	0	1469	
% Lights	85.7%	85.6%	100.0%	0.0%	95.8%	0.0%	0.0%	86.0%	97.8%	92.3%	0.0%	96.7%	0.0%	0.0%	85.7%	96.3%	97.2%	0.0%	96.3%	0.0%	0.0%	94.1%	95.5%	96.4%	0.0%	95.4%	0.0%	0.0%	96.1%	
Trucks	0	3	0	0	3	0	0	0	0	0	0	0	0	0	0	3	0	0	3	0	0	0	0	0	0	0	0	0	6	
% Trucks	0.0%	1.0%	0.0%	0.0%	0.8%	0.0%	0.0%	0.0%	0.0%	0.0%	0.0%	0.0%	0.0%	0.0%	0.0%	0.9%	0.0%	0.0%	0.7%	0.0%	0.0%	0.0%	0.0%	0.0%	0.0%	0.0%	0.0%	0.4%	0.4%	
Buses	2	10	0	0	12	0	0	1	6	5	0	12	0	0	3	9	1	0	13	0	0	2	13	1	0	16	0	0	53	
% Buses	4.3%	3.4%	0.0%	0.0%	0.0%	0.0%	0.0%	4.0%	2.2%	7.7%	0.0%	0.0%	0.0%	0.0%	4.3%	2.8%	2.8%	0.0%	0.0%	0.0%	3.9%	4.5%	3.6%	0.0%	0.0%	0.0%	0.0%	3.5%		
Pedestrians	0	0	0	0	0	3	5	0	0	0	0	3	3	0	0	0	0	6	6	7	0	0	0	0	0	0	4	11	0	
% Pedestrians	0.0%	0.0%	0.0%	0.0%	0.0%	100.0%	100.0%	0.0%	0.0%	0.0%	0.0%	0.0%	100.0%	100.0%	0.0%	0.0%	0.0%	0.0%	0.0%	0.0%	0.0%	0.0%	0.0%	0.0%	0.0%	0.0%	0.0%	80.0%	91.7%	0.0%
Bicycles on Crosswalk	0	0	0	0	0	0	0	0	0	0	0	0	0	0	0	0	0	0	0	0	0	0	0	0	0	0	1	1	0	
% Bicycles on Crosswalk	0.0%	0.0%	0.0%	0.0%	0.0%	0.0%	0.0%	0.0%	0.0%	0.0%	0.0%	0.0%	0.0%	0.0%	0.0%	0.0%	0.0%	0.0%	0.0%	0.0%	0.0%	0.0%	0.0%	0.0%	0.0%	0.0%	20.0%	8.3%	0.0%	

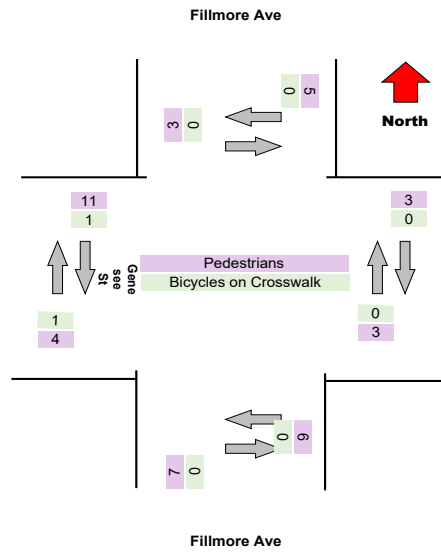
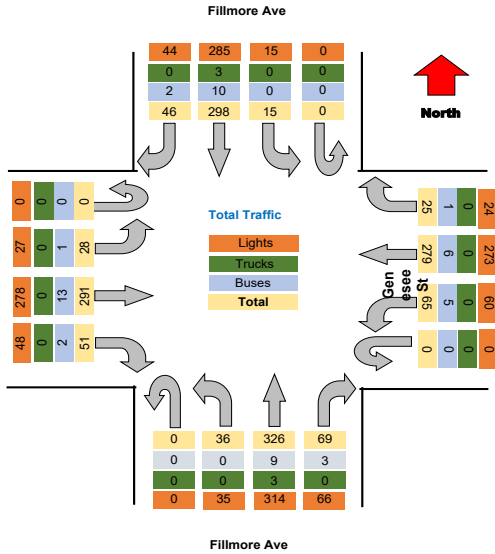

Project : VBH Malta NY
 Site : Site 4
 Location : 42.948550, -73.790036
 Survey Date : 2021-04-28, Wednesday

Turning Movement Data Plot

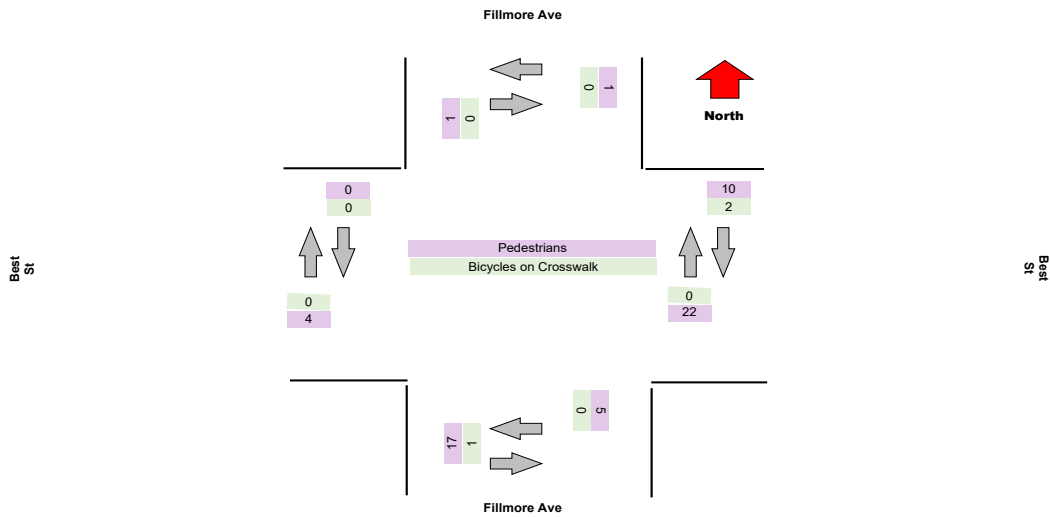
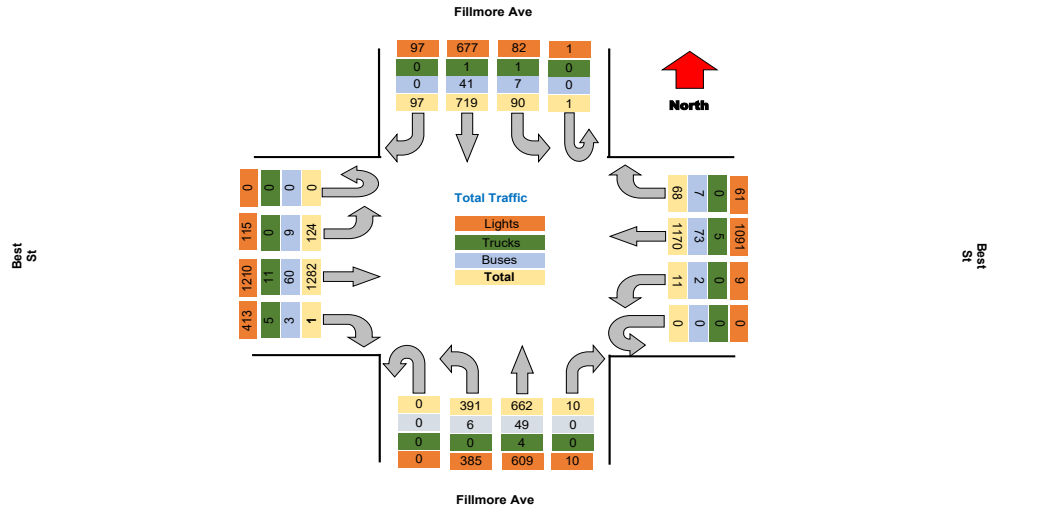

Project : VBH Malta NY
Site : Site 4
Location : 42.948550, -73.790036

TSTData.com

Survey Date : 2021-04-28, Wednesday

Turning Movement Peak Hour Data (AM)

7:30:00 AM

Leg Direction	Fillmore Ave						Best St						Fillmore Ave						Best St						Total				
	Southbound			Westbound			Northbound			Eastbound			Northbound			Eastbound													
Start Time	Right	Thru	Left	U-Turn	App Total	Peds CW	Peds CCW	Right	Thru	Left	U-Turn	App Total	Peds CW	Peds CCW	Right	Thru	Left	U-Turn	App Total	Peds CW	Peds CCW	Right	Thru	Left	U-Turn	App Total	Peds CW	Peds CCW	
7:30:00 AM	7	28	8	0	43	0	0	4	66	1	0	71	0	0	1	39	15	0	59	0	2	24	45	4	0	73	0	0	246
7:45:00 AM	7	55	3	0	65	0	0	6	107	0	0	113	4	2	1	39	30	0	76	0	1	34	69	6	0	109	1	0	363
8:00:00 AM	6	56	8	0	70	1	0	3	78	0	0	81	0	2	0	44	30	0	76	1	1	46	79	8	0	133	0	0	360
8:15:00 AM	4	54	10	0	68	0	0	3	69	1	0	74	3	1	0	37	29	0	70	2	1	28	65	9	0	102	0	0	334
Grand Total	24	193	29	0	246	1	0	16	341	2	0	359	7	5	2	159	104	0	261	3	5	132	258	27	0	417	1	0	1383
% Approach	9.8%	78.5%	11.8%	0.0%	0.0%	0.0%	0.0%	14.2%	85.8%	0.0%	0.0%	0.0%	0.0%	0.0%	45.1%	41.7%	13.2%	0.0%	0.0%	0.0%	0.0%	0.0%	66.2%	33.8%	0.0%	0.0%	0.0%	0.0%	0.0%
% Total	1.8%	14.8%	2.2%	0.0%	18.8%	0.0%	0.0%	1.2%	26.2%	0.2%	0.0%	27.6%	0.0%	0.0%	0.2%	12.2%	8.0%	0.0%	21.6%	0.0%	0.0%	10.1%	19.8%	2.1%	0.0%	32.0%	0.0%	0.0%	
PHF	0.857	0.862	0.725	0.000	0.879	0.000	0.000	0.667	0.787	0.500	0.000	0.794	0.000	0.000	0.500	0.903	0.867	0.000	0.824	0.000	0.000	0.717	0.816	0.750	0.000	0.784	0.000	0.000	
Lights	24	192	23	0	229	0	0	13	322	1	0	336	0	0	2	142	100	0	244	0	0	131	241	27	0	399	0	0	
% Lights	100.0%	94.3%	79.3%	0.0%	93.1%	0.0%	0.0%	81.3%	94.4%	50.0%	0.0%	93.6%	0.0%	0.0%	100.0%	89.3%	96.2%	0.0%	86.8%	0.0%	0.0%	99.2%	93.4%	100.0%	0.0%	95.7%	0.0%	0.0%	
Trucks	0	0	0	0	0	0	0	0	3	0	0	3	0	0	0	2	0	0	2	0	0	1	6	0	0	7	0	0	
% Trucks	0.0%	0.0%	0.0%	0.0%	0.0%	0.0%	0.0%	0.0%	0.9%	0.0%	0.0%	0.8%	0.0%	0.0%	0.0%	1.3%	0.0%	0.0%	0.7%	0.0%	0.0%	0.8%	2.3%	0.0%	0.0%	1.7%	0.0%	0.0%	
Buses	0	11	6	0	17	0	0	3	15	1	0	19	0	0	0	15	4	0	19	0	0	0	11	0	0	11	0	0	
% Buses	0.0%	5.7%	20.7%	0.0%	0.0%	0.0%	0.0%	18.8%	4.4%	50.0%	0.0%	0.0%	0.0%	0.0%	0.0%	9.4%	3.8%	0.0%	0.0%	0.0%	0.0%	0.0%	4.3%	0.0%	0.0%	0.0%	0.0%	0.0%	
Pedestrians	0	0	0	0	0	1	0	0	0	0	0	7	9	0	0	0	0	0	3	5	0	0	0	0	0	0	1	0	
% Pedestrians	0.0%	0.0%	0.0%	0.0%	0.0%	100.0%	0.0%	0.0%	0.0%	0.0%	0.0%	0.0%	100.0%	100.0%	0.0%	0.0%	0.0%	0.0%	0.0%	100.0%	100.0%	0.0%	0.0%	0.0%	0.0%	0.0%	100.0%	0.0%	
Bicycles on Crosswalk	0	0	0	0	0	0	0	0	0	0	0	0	0	0	0	0	0	0	0	0	0	0	0	0	0	0	0	0	
% Bicycles on Crosswalk	0.0%	0.0%	0.0%	0.0%	0.0%	0.0%	0.0%	0.0%	0.0%	0.0%	0.0%	0.0%	0.0%	0.0%	0.0%	0.0%	0.0%	0.0%	0.0%	0.0%	0.0%	0.0%	0.0%	0.0%	0.0%	0.0%	0.0%	0.0%	

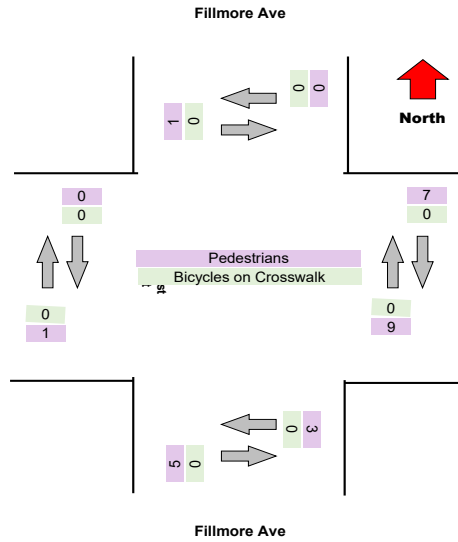
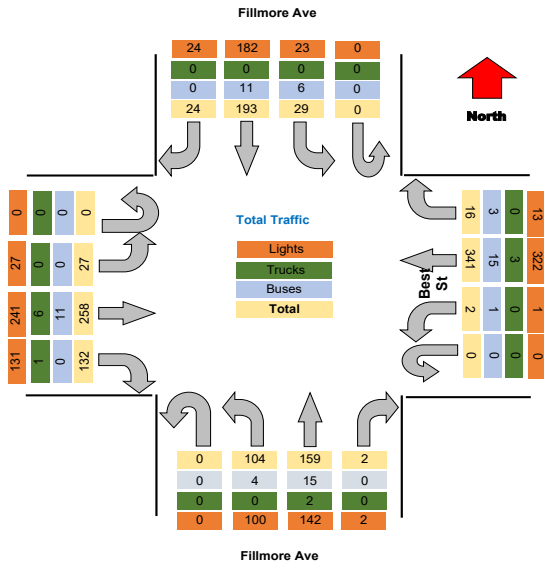

Turning Movement Peak Hour Data (PM)

4:30:00 PM

Leg Direction	Fillmore Ave						Best St						Fillmore Ave						Best St						Total					
	Southbound			Northbound			Westbound			Eastbound			Northbound			Eastbound														
Start Time	Right	Thru	Left	U-Turn	App Total	Peds CW	Peds CCW	Right	Thru	Left	U-Turn	App Total	Peds CW	Peds CCW	Right	Thru	Left	U-Turn	App Total	Peds CW	Peds CCW	Right	Thru	Left	U-Turn	App Total	Peds CW	Peds CCW		
4:30:00 PM	8	60	7	0	75	0	0	11	82	1	0	94	0	1	4	64	27	0	95	0	1	25	149	8	0	182	1	0	446	
4:45:00 PM	7	66	9	0	82	0	0	3	79	1	0	83	0	2	1	73	33	0	107	0	0	35	112	4	0	151	0	0	423	
5:00:00 PM	7	50	11	0	68	0	0	7	79	2	0	88	1	0	0	48	30	0	78	0	0	29	118	8	0	155	1	0	389	
5:15:00 PM	2	48	3	0	53	0	0	7	62	0	0	69	0	2	1	50	36	0	87	0	1	26	91	8	0	125	0	0	354	
Grand Total	24	224	30	0	278	0	0	28	322	4	0	354	1	6	6	235	126	0	367	0	2	115	470	28	0	613	2	0	1612	
% Approach	8.6%	89.6%	10.8%	0.0%	0.0%	0.0%	0.0%	14.2%	85.8%	0.0%	0.0%	0.0%	0.0%	0.0%	45.1%	41.7%	13.2%	0.0%	0.0%	0.0%	0.0%	0.0%	66.2%	33.8%	0.0%	0.0%	0.0%	0.0%	0.0%	
% Total	1.5%	13.9%	1.9%	0.0%	17.2%	0.0%	0.0%	1.7%	20.0%	0.2%	0.0%	22.0%	0.0%	0.0%	0.4%	14.6%	7.8%	0.0%	22.8%	0.0%	0.0%	7.1%	29.2%	1.7%	0.0%	38.0%	0.0%	0.0%	0.0%	
PHF	0.750	0.848	0.682	0.000	0.848	0.000	0.000	0.636	0.982	0.500	0.000	0.941	0.000	0.000	0.375	0.805	0.875	0.000	0.857	0.000	0.000	0.821	0.789	0.875	0.000	0.842	0.000	0.000	0.904	
Lights	24	214	29	0	267	0	0	27	316	3	0	346	0	0	6	222	125	0	353	0	0	113	451	26	0	590	0	0	1566	
% Lights	100.0%	95.5%	96.7%	0.0%	96.0%	0.0%	0.0%	96.4%	98.1%	75.0%	0.0%	97.7%	0.0%	0.0%	100.0%	94.5%	99.2%	0.0%	96.2%	0.0%	0.0%	98.3%	96.0%	92.9%	0.0%	96.2%	0.0%	0.0%	96.5%	
Trucks	0	1	0	0	1	0	0	0	1	0	0	1	0	0	0	1	0	0	1	0	0	1	0	0	0	1	0	0	4	
% Trucks	0.0%	0.4%	0.0%	0.0%	0.4%	0.0%	0.0%	0.0%	0.3%	0.0%	0.0%	0.3%	0.0%	0.0%	0.0%	0.4%	0.0%	0.0%	0.3%	0.0%	0.0%	0.9%	0.0%	0.0%	0.0%	0.2%	0.0%	0.0%	0.2%	
Buses	0	9	1	0	10	0	0	1	5	1	0	7	0	0	0	12	1	0	13	0	0	1	19	2	0	22	0	0	52	
% Buses	0.0%	4.0%	3.3%	0.0%	3.6%	0.0%	0.0%	3.6%	1.6%	25.0%	0.0%	2.0%	0.0%	0.0%	0.0%	5.1%	0.8%	0.0%	3.6%	0.0%	0.0%	0.9%	4.0%	7.1%	0.0%	3.6%	0.0%	0.0%	3.2%	
Pedestrians	0	0	0	0	0	0	0	0	0	0	0	0	5	0	0	0	0	0	0	2	0	0	0	0	0	0	2	0	0	
% Pedestrians	0.0%	0.0%	0.0%	0.0%	0.0%	100.0%	0.0%	0.0%	0.0%	0.0%	0.0%	0.0%	100.0%	0.0%	0.0%	0.0%	0.0%	0.0%	0.0%	0.6%	0.0%	100.0%	0.0%	0.0%	0.0%	0.0%	0.0%	100.0%	0.0%	0.0%
Bicycles on Crosswalk	0	0	0	0	0	0	0	0	0	0	0	1	0	0	0	0	0	0	0	0	0	0	0	0	0	0	0	0	0	
% Bicycles on Crosswalk	0.0%	0.0%	0.0%	0.0%	0.0%	0.0%	0.0%	0.0%	0.0%	0.0%	0.0%	0.0%	100.0%	0.0%	0.0%	0.0%	0.0%	0.0%	0.0%	0.0%	0.0%	0.0%	0.0%	0.0%	0.0%	0.0%	0.0%	0.0%	0.0%	

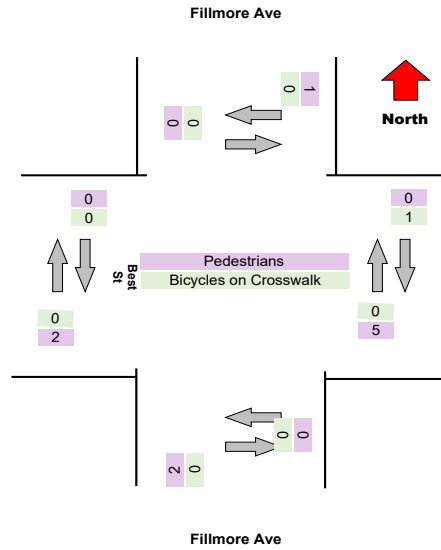
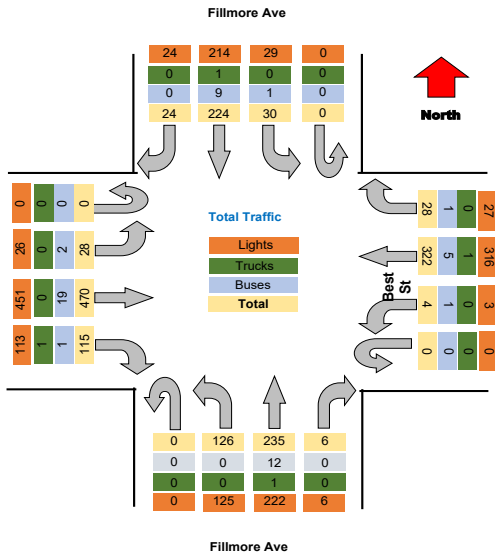



Project : VBH Malta NY
 Site : Site 4
 Location : 42.948550, -73.790036

TSTData.com

Survey Date : 2021-04-28, Wednesday

Project	Labella
Project Code	Labella
Site Name	16
Legs and Movements	All Processed Legs & Move
Bin Size	15 minutes
Survey Date	2021-10-27, Wednesday
Location	16
Latitude and Longitude	42.903669, -78.839296

	Start	End	PHF
Forced Peak AM	2021/10/27 07:30:00	2021/10/27 08:30:00	0.93
Forced Peak PM	2021/10/27 16:30:00	2021/10/27 17:30:00	0.93
AM Peak	2021/10/27 07:30:00	2021/10/27 08:30:00	0.93
PM Peak	2021/10/27 16:30:00	2021/10/27 17:30:00	0.93

Turning Movement Data

Leg Direction	Fillmore Ave												Best St				Fillmore Ave												Best St				Total
	Southbound						Westbound						Northbound						Eastbound														
	Right	Thru	Left	U-Turn	App Total	Peds CV	Right	Thru	Left	U-Turn	App Total	Peds CV	Right	Thru	Left	U-Turn	App Total	Peds CV	Right	Thru	Left	U-Turn	App Total	Peds CV									
Start Time																																	
6:30:00 AM	3	19	0	0	22	0	0	1	46	1	0	48	0	0	0	12	4	0	16	0	0	15	32	3	0	50	0	0	136				
6:45:00 AM	1	28	0	0	29	0	0	1	88	1	0	90	0	0	0	23	11	0	34	0	0	14	20	4	0	38	0	0	171				
Hourly Total	4	47	0	0	51	0	0	2	114	2	0	118	0	0	0	35	15	0	50	0	0	29	52	7	0	58	0	0	307				
7:00:00 AM	3	33	1	0	37	0	0	2	36	2	0	40	1	0	1	23	12	0	42	0	4	16	25	4	0	45	0	0	164				
7:15:00 AM	2	23	1	0	26	2	0	5	61	2	0	68	4	2	3	24	15	0	48	0	0	19	37	6	0	62	0	0	204				
7:30:00 AM	8	31	2	0	41	1	1	1	82	0	0	84	3	6	2	39	20	0	70	2	4	31	52	7	0	90	0	0	285				
7:45:00 AM	3	53	3	0	59	1	1	5	98	0	0	104	3	3	2	49	27	0	84	1	1	31	77	4	0	112	0	0	359				
Hourly Total	16	140	7	0	163	4	2	13	277	4	0	296	11	16	8	135	74	0	244	3	9	97	191	21	0	309	0	0	1012				
8:00:00 AM	6	57	6	0	69	0	0	3	83	1	0	87	0	0	0	38	26	0	64	4	1	33	80	6	0	119	2	0	339				
8:15:00 AM	5	51	12	0	68	0	0	6	97	0	0	103	1	0	0	39	39	0	79	0	1	33	72	5	0	110	2	0	360				
Hourly Total	11	108	18	0	137	0	0	9	180	1	0	190	1	0	0	77	65	0	143	4	2	66	152	11	0	229	4	0	699				
4:00:00 PM	19	86	3	0	108	0	0	4	91	1	0	96	4	1	3	50	36	0	89	3	0	28	114	14	0	156	0	3	449				
4:15:00 PM	10	63	7	0	80	0	0	8	98	0	0	106	2	1	0	67	29	0	96	1	1	37	107	7	0	151	3	0	433				
4:30:00 PM	11	48	3	0	62	0	1	8	94	1	0	103	4	0	2	66	37	0	105	0	0	42	116	13	0	171	0	4	441				
4:45:00 PM	10	64	4	0	78	0	0	6	83	0	0	89	0	1	0	50	41	0	91	1	0	39	88	8	0	145	0	0	403				
Hourly Total	50	261	17	0	328	0	1	26	368	2	0	394	10	3	5	233	143	0	381	5	1	146	435	42	0	623	3	7	1726				
5:00:00 PM	14	64	9	0	87	0	0	8	95	0	0	103	0	1	2	51	34	0	87	0	0	32	85	8	0	125	0	0	402				
5:15:00 PM	9	44	9	0	62	0	0	7	101	0	0	108	0	0	1	47	30	0	78	2	0	37	95	7	0	139	0	1	387				
5:30:00 PM	12	64	4	0	80	0	1	7	86	0	0	93	3	0	0	44	43	0	87	0	0	29	100	5	0	134	1	0	394				
5:45:00 PM	9	40	6	0	55	0	0	4	81	1	0	86	0	0	1	38	36	0	75	0	0	23	79	6	0	108	0	0	324				
Hourly Total	44	212	28	0	284	0	1	26	363	1	0	390	3	1	4	180	143	0	327	2	0	121	359	26	0	506	1	1	1507				
Grand Total	125	788	70	0	963	4	4	76	1300	10	0	1388	25	20	17	660	440	0	1145	14	12	459	1189	107	0	1755	8	8	5281				
% Approach	13.0%	79.8%	7.3%	0.0%	0.0%	0.0%	0.0%	5.5%	93.7%	0.7%	0.0%	0.0%	0.0%	0.0%	1.5%	57.6%	38.4%	0.0%	0.0%	0.0%	0.0%	26.2%	67.7%	6.1%	0.0%	0.0%	0.0%	0.0%	0.0%				
% Total	2.4%	14.6%	1.3%	0.0%	18.3%	0.0%	0.0%	1.4%	24.8%	0.2%	0.0%	26.4%	0.0%	0.0%	0.3%	12.6%	8.4%	0.0%	21.8%	0.0%	0.0%	8.7%	22.6%	2.0%	0.0%	33.4%	0.0%	0.0%	0.0%				
Lights	123	717	84	0	904	0	0	86	1210	8	0	1284	0	0	17	607	434	0	1088	0	0	451	1117	97	0	1665	0	0	4911				
% Lights	98.4%	93.4%	91.4%	0.0%	93.8%	0.0%	0.0%	95.8%	93.1%	80.0%	0.0%	92.5%	0.0%	0.0%	100.0%	92.0%	98.8%	0.0%	92.4%	0.0%	0.0%	98.3%	93.8%	90.7%	0.0%	94.9%	0.0%	0.0%	93.5%				
Trucks	0	1	0	0	1	0	0	0	7	0	0	7	0	0	0	3	1	0	4	0	0	1	8	0	0	9	0	0	21				
% Trucks	0.0%	0.1%	0.0%	0.0%	0.1%	0.0%	0.0%	0.0%	0.5%	0.0%	0.0%	0.5%	0.0%	0.0%	0.0%	0.5%	0.2%	0.0%	0.3%	0.0%	0.0%	0.2%	0.7%	0.0%	0.0%	0.5%	0.0%	0.0%	0.4%				
Buses	2	47	6	0	55	0	0	10	83	2	0	95	0	0	0	48	5	0	53	0	0	5	83	10	0	78	0	0	281				
% Buses	1.6%	6.1%	8.6%	0.0%	0.0%	0.0%	0.0%	0.0%	6.4%	20.0%	0.0%	0.0%	0.0%	0.0%	0.0%	7.3%	1.1%	0.0%	0.0%	0.0%	0.0%	1.1%	5.3%	9.3%	0.0%	0.0%	0.0%	0.0%	5.4%				
Pedestrians	0	0	0	0	0	4	4	0	0	0	0	0	25	17	0	0	0	0	0	14	12	0	0	0	0	0	7	7	0				
% Pedestrians	0.0%	0.0%	0.0%	0.0%	0.0%	100.0%	100.0%	0.0%	0.0%	0.0%	0.0%	0.0%	100.0%	85.0%	0.0%	0.0%	0.0%	0.0%	0.0%	100.0%	100.0%	0.0%	0.0%	0.0%	0.0%	0.0%	87.5%	87.5%	0.0%				
Bicycles on Crosswalk	0	0	0	0	0	0	0	0	0	0	0	0	0	3	0	0	0	0	0	0	0	0	0	0	0	0	1	1	0				
% Bicycles on Crosswalk	0.0%	0.0%	0.0%	0.0%	0.0%	0.0%	0.0%	0.0%	0.0%	0.0%	0.0%	0.0%	0.0%	15.0%	0.0%	0.0%	0.0%	0.0%	0.0%	0.0%	0.0%	0.0%	0.0%	0.0%	0.0%	0.0%	12.5%	12.5%	0.0%				

Turning Movement Data Plot

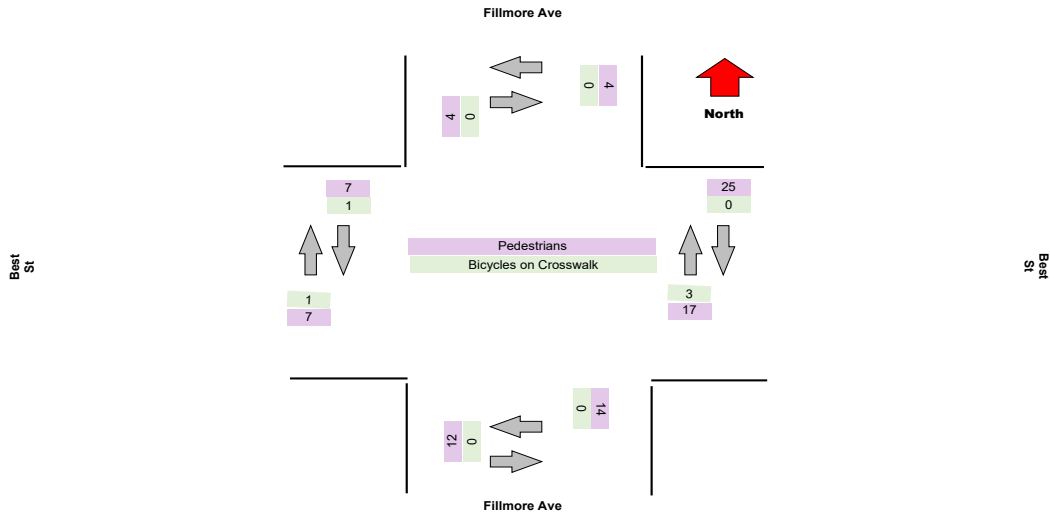
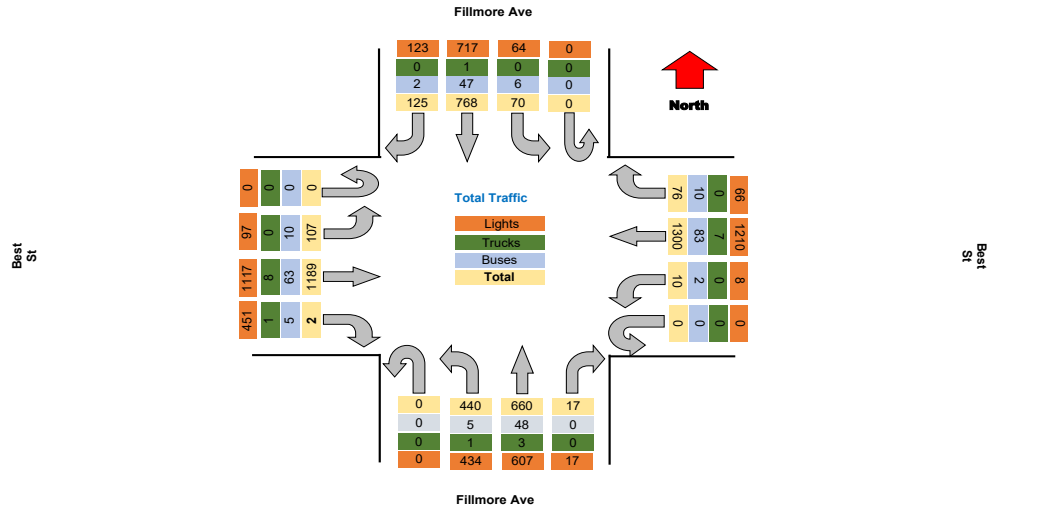

Project : VBH Malta NY
Site : Site 4
Location : 42.948550, -73.790036

TSTData.com

Survey Date : 2021-04-28, Wednesday

Turning Movement Peak Hour Data (AM)

7:30:00 AM

Leg Direction	Fillmore Ave								Best St								Fillmore Ave								Best St								Total
	Southbound				Westbound				Northbound				Eastbound				Northbound				Eastbound												
Start Time	Right	Thru	Left	U-Turn	App Total	Peds CW	Peds CCW	Right	Thru	Left	U-Turn	App Total	Peds CW	Peds CCW	Right	Thru	Left	U-Turn	App Total	Peds CW	Peds CCW	Right	Thru	Left	U-Turn	App Total	Peds CW	Peds CCW					
7:30:00 AM	8	31	2	0	41	1	1	1	82	0	0	84	3	6	2	39	20	0	70	2	4	31	52	7	0	90	0	0	285				
7:45:00 AM	3	53	3	0	59	1	1	5	98	0	0	104	3	3	2	49	27	0	84	1	1	31	77	4	0	112	0	0	359				
8:00:00 AM	6	57	6	0	69	0	0	3	83	1	0	87	0	0	0	38	26	0	64	4	1	33	90	6	0	119	2	0	339				
8:15:00 AM	5	51	12	0	68	0	0	6	87	0	0	103	1	0	0	39	39	0	79	0	1	33	72	5	0	110	2	0	360				
Grand Total	22	192	23	0	237	2	2	15	360	1	0	378	7	9	4	155	112	0	297	7	7	128	281	22	0	431	4	0	1343				
% Approach	9.3%	81.0%	9.7%	0.0%	0.0%	0.0%	0.0%	14.2%	85.8%	0.0%	0.0%	0.0%	0.0%	0.0%	45.1%	41.7%	13.2%	0.0%	0.0%	0.0%	0.0%	0.0%	66.2%	33.8%	0.0%	0.0%	0.0%	0.0%	0.0%				
% Total	1.6%	14.3%	1.7%	0.0%	17.6%	0.0%	0.0%	1.1%	26.8%	0.1%	0.0%	28.1%	0.0%	0.0%	0.3%	12.3%	8.3%	0.0%	22.1%	0.0%	0.0%	9.5%	20.9%	1.6%	0.0%	32.1%	0.0%	0.0%	0.0%				
PHF	0.688	0.842	0.479	0.000	0.859	0.000	0.000	0.625	0.918	0.250	0.000	0.909	0.000	0.000	0.500	0.842	0.718	0.000	0.884	0.000	0.000	0.970	0.878	0.786	0.000	0.905	0.000	0.000	0.933				
Lights	21	177	17	0	215	0	0	11	338	1	0	350	0	0	4	147	109	0	260	0	0	127	265	22	0	414	0	0	1239				
% Trucks	0.0%	0.0%	0.0%	0.0%	0.0%	0.0%	0.0%	0.0%	1.7%	0.0%	0.0%	1.6%	0.0%	0.0%	0.0%	0.6%	0.0%	0.0%	0.3%	0.0%	0.0%	0.0%	1.8%	0.0%	0.0%	1.2%	0.0%	0.0%	0.9%				
Buses	1	14	6	0	21	0	0	4	16	0	0	20	0	0	0	17	3	0	20	0	0	1	11	0	0	12	0	0	73				
% Buses	4.5%	7.3%	26.1%	0.0%	0.0%	0.0%	0.0%	28.7%	4.4%	0.0%	0.0%	0.0%	0.0%	0.0%	0.0%	10.3%	2.7%	0.0%	0.0%	0.0%	0.0%	0.8%	3.9%	0.0%	0.0%	0.0%	0.0%	0.0%	5.4%				
Pedestrians	0	0	0	0	0	2	2	0	0	0	0	7	8	0	0	0	0	0	7	7	0	0	0	0	0	0	4	0	0				
% Pedestrians	0.0%	0.0%	0.0%	0.0%	0.0%	100.0%	100.0%	0.0%	0.0%	0.0%	0.0%	0.0%	100.0%	88.9%	0.0%	0.0%	0.0%	0.0%	0.0%	0.0%	0.0%	0.0%	0.0%	0.0%	0.0%	0.0%	0.0%	100.0%	0.0%				
Bicycles on Crosswalk	0	0	0	0	0	0	0	0	0	0	0	0	1	0	0	0	0	0	0	0	0	0	0	0	0	0	0	0	0				
% Bicycles on Crosswalk	0.0%	0.0%	0.0%	0.0%	0.0%	0.0%	0.0%	0.0%	0.0%	0.0%	0.0%	0.0%	0.0%	11.1%	0.0%	0.0%	0.0%	0.0%	0.0%	0.0%	0.0%	0.0%	0.0%	0.0%	0.0%	0.0%	0.0%	0.0%	0.0%				

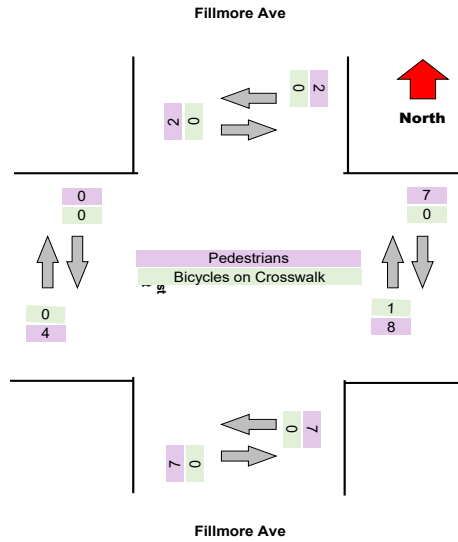
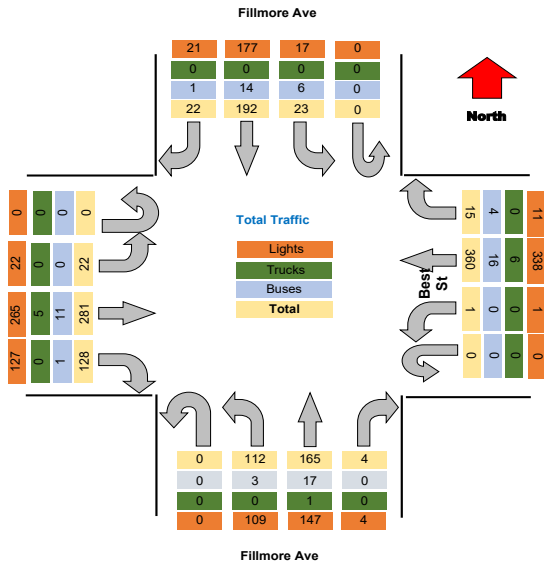

Project : VBH Malta NY
Site : Site 4
Location : 42.948550, -73.790036

TSTData.com

Survey Date : 2021-04-28, Wednesday

Turning Movement Peak Hour Data (PM)

4:30:00 PM

Leg Direction	Fillmore Ave										Best St										Fillmore Ave										Best St										Total
	Southbound					Westbound					Northbound					Eastbound																									
	Right	Thru	Left	U-Turn	App Total	Right	Thru	Left	U-Turn	App Total	Right	Thru	Left	U-Turn	App Total	Right	Thru	Left	U-Turn	App Total																					
4:30:00 PM	11	48	3	0	62	0	1	8	94	1	0	103	4	0	2	66	37	0	105	0	0	42	116	13	0	171	0	4	441												
4:45:00 PM	10	64	4	0	78	0	0	6	83	0	0	89	0	1	1	50	41	0	91	1	0	39	98	8	0	145	0	0	403												
5:00:00 PM	14	64	9	0	87	0	0	8	95	0	0	103	0	1	2	51	34	0	87	0	0	32	85	8	0	125	0	0	402												
5:15:00 PM	9	44	9	0	62	0	0	7	101	0	0	108	0	0	1	47	30	0	78	2	0	37	85	7	0	139	0	1	387												
Grand Total	44	220	25	0	289	0	1	29	373	1	0	423	4	1	5	214	142	0	361	3	0	150	364	36	0	590	3	5	1633												
% Approach	15.2%	76.1%	8.7%	0.0%	0.0%	0.0%	0.0%	14.2%	85.8%	0.0%	0.0%	0.0%	45.1%	41.7%	13.2%	0.0%	0.0%	0.0%	0.0%	0.0%	66.2%	33.8%	0.0%	0.0%	0.0%	0.0%	0.0%	0.0%	0.0%												
% Total	2.7%	13.5%	1.5%	0.0%	17.7%	0.0%	0.0%	1.8%	22.8%	0.1%	0.0%	24.7%	0.3%	13.1%	8.7%	0.0%	22.1%	0.0%	0.0%	9.2%	24.1%	2.2%	0.0%	35.5%	0.0%	0.0%	0.0%														
PHF	0.786	0.859	0.694	0.000	0.830	0.000	0.000	0.906	0.923	0.250	0.000	0.933	0.000	0.000	0.625	0.811	0.866	0.000	0.860	0.000	0.000	0.893	0.849	0.692	0.000	0.848	0.000	0.000	0.926												
Lights	44	206	25	0	275	0	0	28	365	1	0	394	0	0	5	204	141	0	350	0	0	147	374	32	0	553	0	0	1572												
% Lights	100.0%	93.6%	100.0%	0.0%	95.2%	0.0%	0.0%	96.6%	97.9%	100.0%	0.0%	97.8%	0.0%	0.0%	100.0%	95.3%	99.3%	0.0%	97.0%	0.0%	0.0%	98.0%	94.9%	88.9%	0.0%	95.3%	0.0%	0.0%	96.3%												
Trucks	0	1	0	0	1	0	0	0	1	0	0	1	0	0	0	1	0	0	1	0	0	1	0	0	0	1	0	0	4												
% Trucks	0.0%	0.5%	0.0%	0.0%	0.3%	0.0%	0.0%	0.0%	0.3%	0.0%	0.0%	0.2%	0.0%	0.0%	0.0%	0.5%	0.0%	0.0%	0.3%	0.0%	0.0%	0.7%	0.0%	0.0%	0.0%	0.2%	0.0%	0.0%	0.2%												
Buses	0	12	0	0	12	1	0	7	0	0	0	8	0	0	0	9	1	0	10	0	0	1	20	4	0	25	0	0	56												
% Buses	0.0%	5.5%	0.0%	0.0%	0.0%	3.4%	1.9%	0.0%	0.0%	0.0%	0.0%	0.0%	0.0%	0.0%	0.0%	4.2%	0.7%	0.0%	0.0%	0.0%	0.0%	0.7%	5.1%	11.1%	0.0%	0.0%	0.0%	0.0%	3.4%												
Pedestrians	0	0	0	0	0	1	0	0	0	0	0	1	0	0	0	0	0	0	3	0	0	0	0	0	0	0	0	0	5												
% Pedestrians	0.0%	0.0%	0.0%	0.0%	0.0%	0.0%	0.0%	0.0%	0.0%	0.0%	0.0%	0.0%	0.0%	0.0%	0.0%	0.0%	0.0%	0.0%	0.0%	0.0%	0.0%	0.0%	0.0%	0.0%	0.0%	0.0%	0.0%	0.0%	0.0%												
Bicycles on Crosswalk	0	0	0	0	0	0	0	0	0	0	0	1	0	0	0	0	0	0	0	0	0	0	0	0	0	0	0	0	0												
% Bicycles on Crosswalk	0.0%	0.0%	0.0%	0.0%	0.0%	0.0%	0.0%	0.0%	0.0%	0.0%	0.0%	0.0%	0.0%	0.0%	0.0%	0.0%	0.0%	0.0%	0.0%	0.0%	0.0%	0.0%	0.0%	0.0%	0.0%	0.0%	0.0%	0.0%	0.0%												

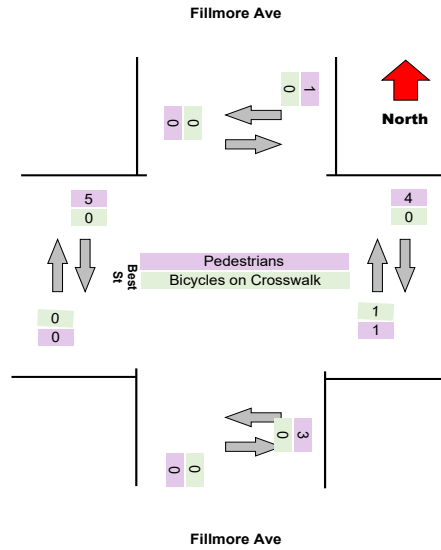
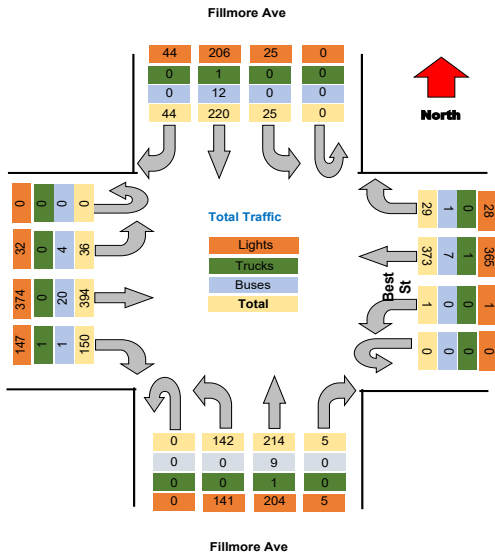

Project : VBH Malta NY
Site : Site 4
Location : 42.948550, -73.790036

TSTData.com

Survey Date : 2021-04-28, Wednesday

Project	Labella
Project Code	Labella
Site Name	16
Legs and Movements	All Processed Legs & Move
Bin Size	15 minutes
Survey Date	2021-10-28, Thursday
Location	16
Latitude and Longitude	42.903669, -78.839296

	Start	End	PHF
Forced Peak AM	2021/10/28 07:30:00	2021/10/28 08:30:00	0.85
Forced Peak PM	2021/10/28 16:30:00	2021/10/28 17:30:00	0.96
AM Peak	2021/10/28 07:30:00	2021/10/28 08:30:00	0.85
PM Peak	2021/10/28 16:30:00	2021/10/28 17:30:00	0.96

Turning Movement Data

Leg Direction	Fillmore Ave										Best St										Fillmore Ave										Best St										Total
	Southbound					Westbound					Northbound					Eastbound					Southbound					Westbound					Northbound					Eastbound					
	Right	Thru	Left	U-Turn	App Total	Right	Thru	Left	U-Turn	App Total	Right	Thru	Left	U-Turn	App Total	Right	Thru	Left	U-Turn	App Total	Right	Thru	Left	U-Turn	App Total	Right	Thru	Left	U-Turn	App Total	Right	Thru	Left	U-Turn	App Total	Right	Thru	Left	U-Turn	App Total	
6:30:00 AM	2	12	1	0	15	0	0	0	1	45	0	0	0	46	0	0	0	0	46	0	10	8	0	18	0	0	6	31	2	2	0	39	0	0	118						
6:45:00 AM	0	23	0	0	23	0	0	0	3	67	0	0	0	64	4	0	0	0	20	10	0	34	0	0	18	43	8	0	69	0	0	190									
Hourly Total	2	35	1	0	38	0	0	0	4	106	0	0	0	110	4	0	0	0	30	18	0	52	0	0	24	74	10	0	108	0	0	308									
7:00:00 AM	9	19	0	0	28	0	0	0	2	51	0	0	0	53	1	1	0	0	13	6	0	21	0	3	13	30	4	0	47	0	1	149									
7:15:00 AM	5	24	2	0	31	0	0	0	3	52	0	0	0	55	4	2	1	0	22	13	0	42	0	1	16	50	9	0	75	0	0	203									
7:30:00 AM	7	32	1	0	40	0	1	0	3	73	1	0	0	78	1	3	2	0	61	19	0	86	0	3	22	48	2	0	72	0	1	276									
7:45:00 AM	9	51	0	0	60	2	0	0	3	95	0	0	0	98	3	5	1	0	46	25	0	80	0	1	40	67	10	0	117	0	0	355									
Hourly Total	30	126	3	0	159	2	1	0	11	271	1	0	0	284	9	11	4	0	142	63	0	229	0	8	91	195	25	0	311	0	2	893									
8:00:00 AM	13	64	6	0	83	2	1	0	4	87	0	0	0	92	0	3	1	0	45	36	0	86	1	4	31	100	16	0	147	0	0	407									
8:15:00 AM	8	54	9	0	71	2	1	0	3	80	1	0	0	85	1	0	0	0	37	27	0	68	2	0	40	70	6	0	116	0	0	340									
Hourly Total	21	118	15	0	154	4	2	0	7	167	1	0	0	177	1	3	4	0	82	63	0	153	3	4	71	170	22	0	263	0	0	747									
4:00:00 PM	12	68	6	0	86	1	4	0	12	91	0	0	0	103	0	0	0	2	45	44	0	91	0	1	34	97	10	1	142	0	1	422									
4:15:00 PM	7	56	13	0	76	1	0	0	12	91	1	0	0	104	0	2	0	0	50	51	0	103	0	1	44	124	13	0	181	0	1	464									
4:30:00 PM	13	61	7	0	81	0	2	0	6	102	0	0	0	108	0	0	0	0	55	45	0	100	0	2	32	108	10	0	150	0	0	439									
4:45:00 PM	9	59	15	0	82	1	0	0	4	94	0	0	0	99	3	0	0	0	68	43	0	114	2	3	37	100	7	0	144	1	0	438									
Hourly Total	41	243	41	0	325	3	6	0	34	378	1	0	0	413	3	2	7	0	218	183	0	408	2	7	147	429	40	1	617	1	2	1763									
5:00:00 PM	7	46	14	0	67	3	0	0	12	80	0	0	0	92	0	3	1	0	50	26	0	77	2	0	26	110	6	0	142	0	0	378									
5:15:00 PM	16	65	8	0	89	0	0	0	6	96	1	0	0	103	1	0	0	1	56	33	0	90	1	0	33	100	11	0	144	0	0	426									
5:30:00 PM	16	61	9	0	86	1	0	0	9	101	1	0	0	111	1	0	0	3	51	33	0	87	0	1	41	101	8	0	150	0	0	434									
5:45:00 PM	12	48	4	0	64	4	0	0	6	90	0	0	0	96	0	1	0	0	40	34	0	74	0	0	37	82	5	0	124	0	2	358									
Hourly Total	51	220	35	0	306	8	0	0	33	367	2	0	0	402	2	4	4	5	197	126	0	328	3	1	137	393	30	0	560	0	2	1596									
Grand Total	145	742	95	0	882	17	9	0	89	1289	5	0	0	1386	15	20	20	20	669	453	0	1170	8	20	470	1281	127	1	1899	1	6	5397									
% Approach	14.8%	75.6%	8.7%	0.0%	0.0%	0.0%	0.0%	6.4%	93.0%	0.4%	0.0%	0.0%	1.7%	57.2%	38.7%	0.0%	0.0%	1.7%	57.2%	38.7%	0.0%	0.0%	0.0%	0.0%	25.3%	67.8%	6.8%	0.1%	0.0%	0.0%	0.0%	0.0%									
% Total	2.7%	13.7%	1.8%	0.0%	18.2%	0.0%	0.0%	1.6%	23.9%	0.1%	0.0%	0.0%	0.4%	12.4%	8.4%	0.0%	0.0%	0.4%	12.4%	8.4%	0.0%	21.7%	0.0%	0.0%	8.7%	23.4%	2.4%	0.0%	34.4%	0.0%	0.0%	0.0%									
Lights	141	694	91	0	926	0	0	82	1206	4	0	0	19	614	445	0	0	460	1192	116	1	1078	0	0	26	110	6	0	142	0	0	5065									
% Lights	97.2%	93.5%	95.9%	0.0%	94.3%	0.0%	0.0%	52.1%	93.6%	80.0%	0.0%	93.2%	95.0%	91.8%	98.2%	0.0%	92.1%	97.9%	94.5%	91.3%	98.2%	0.0%	0.0%	99.9%	94.5%	91.3%	98.2%	95.2%	0.0%	0.0%	93.9%										
Trucks	2	2	0	0	4	0	0	1	3	0	0	0	0	1	3	0	0	0	1	3	0	4	0	0	2	5	2	0	9	0	0	21									
% Trucks	1.4%	0.3%	0.0%	0.0%	0.4%	0.0%	0.0%	1.1%	0.2%	0.0%	0.0%	0.3%	0.0%	0.0%	0.1%	0.7%	0.0%	0.3%	0.0%	0.1%	0.7%	0.0%	0.3%	0.0%	0.4%	0.4%	1.6%	0.0%	0.5%	0.0%	0.0%	0.4%									
Buses	1	46	4	0	51	0	0	6	79	1	0	0	1	47	4	0	0	6	47	4	0	52	0	0	6	82	9	0	77	0	0	266									
% Buses	0.7%	6.2%	4.2%	0.0%	0.0%	0.0%	0.0%	0.0%	6.1%	20.0%	0.0%	0.0%	5.0%	7.0%	0.9%	0.0%	0.0%	1.3%	4.9%	7.1%	0.0%	0.0%	0.0%	0.0%	1.3%	4.9%	7.1%	0.0%	0.0%	0.0%	0.0%	4.9%									
Pedestrians	0	0	0	0	0	17	9	0	0	0	0	0	0	18	15	0	0	0	0	0	0	0	8	12	0	0	0	0	0	1	4	0									
% Pedestrians	0.0%	0.0%	0.0%	0.0%	0.0%	100.0%	100.0%	0.0%	0.0%	0.0%	0.0%	0.0%	0.0%	94.7%	75.0%	0.0%	100.0%	100.0%	0.0%	0.0%	0.0%	0.0%	100.0%	60.0%	0.0%	0.0%	0.0%	0.0%	0.0%	0.0%	66.7%	0.0%									
Bicycles on Crosswalk	0	0	0	0	0	0	0	0	0	0	0	0	1	5	0	0	0	0	0	0	0	0	8	0	0	0	0	0	0	0	2	0									
% Bicycles on Crosswalk	0.0%	0.0%	0.0%	0.0%	0.0%	0.0%	0.0%	0.0%	0.0%	0.0%	0.0%	0.0%	5.3%	25.0%	0.0%	0.0%	0.0%	0.0%	0.0%	0.0%	0.0%	0.0%	40.0%	0.0%	0.0%	0.0%	0.0%	0.0%	0.0%	0.0%	33.3%	0.0%									

Project : VBH Malta NY
 Site : Site 4
 Location : 42.948550, -73.790036
 Survey Date : 2021-04-28, Wednesday

Turning Movement Data Plot

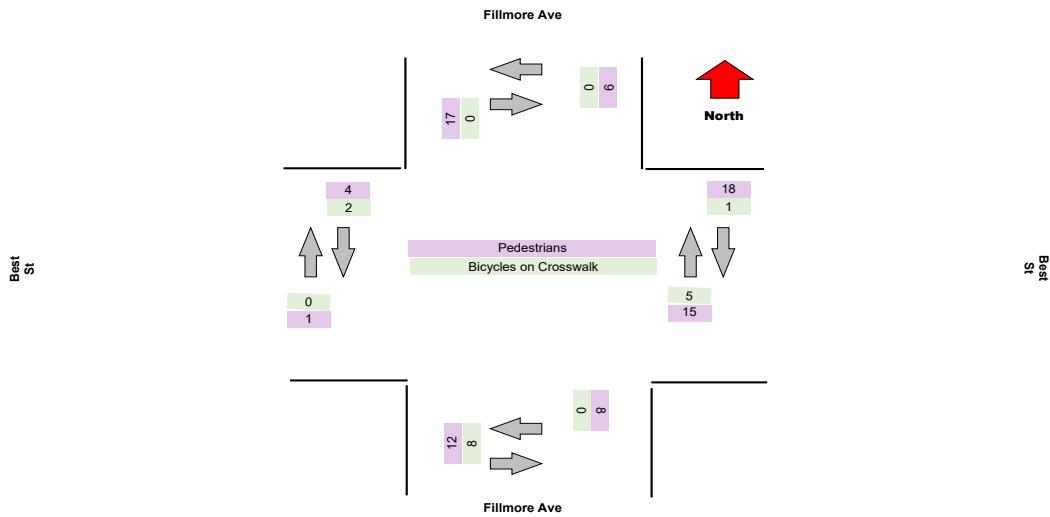
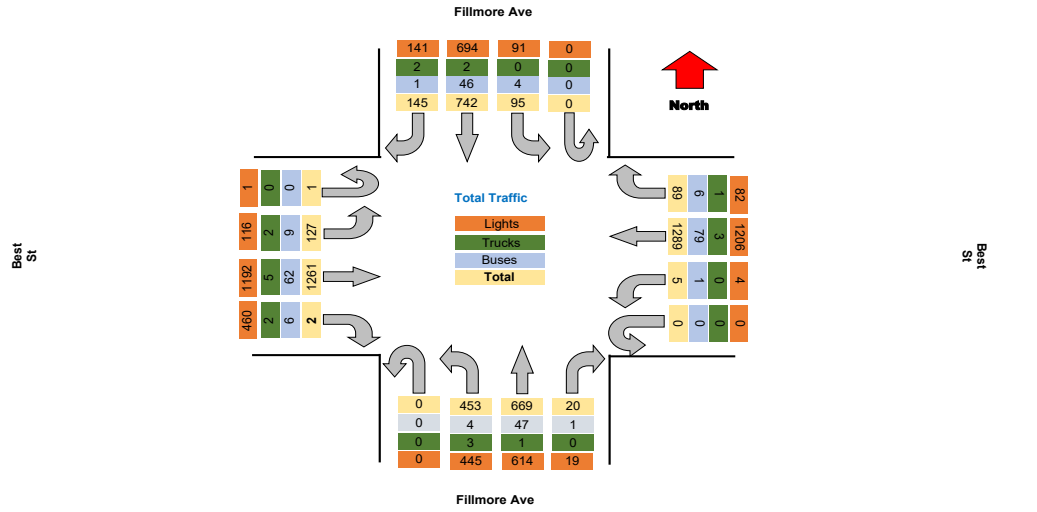

Project : VBH Malta NY
Site : Site 4
Location : 42.948550, -73.790036
Survey Date : 2021-04-28, Wednesday

TSTData.com

Turning Movement Peak Hour Data (AM)

7:30:00 AM

Leg Direction	Fillmore Ave						Best St						Fillmore Ave						Best St						Total					
	Southbound			Westbound			Northbound			Eastbound			Northbound			Eastbound														
Start Time	Right	Thru	Left	U-Turn	App Total	Peds CW	Peds CCW	Right	Thru	Left	U-Turn	App Total	Peds CW	Peds CCW	Right	Thru	Left	U-Turn	App Total	Peds CW	Peds CCW	Right	Thru	Left	U-Turn	App Total	Peds CW	Peds CCW		
7:30:00 AM	7	32	1	0	40	0	1	3	73	1	0	78	1	3	2	61	19	0	86	0	3	22	48	2	0	72	0	1	276	
7:45:00 AM	9	51	0	0	60	2	0	3	95	0	0	98	3	5	1	46	25	0	80	0	1	40	67	10	0	117	0	0	355	
8:00:00 AM	13	64	6	0	83	2	1	4	87	0	0	92	0	3	1	45	36	0	85	1	4	31	100	16	0	147	0	0	407	
8:15:00 AM	8	54	9	0	71	2	1	3	80	1	0	85	1	0	3	37	27	0	68	2	0	40	70	5	0	116	0	0	340	
Grand Total	37	201	16	0	254	6	3	13	335	2	0	353	6	11	7	189	107	0	319	3	8	133	285	34	0	452	3	1	1378	
% Approach	14.6%	79.1%	6.3%	0.0%	0.0%	0.0%	0.0%	14.2%	85.8%	0.0%	0.0%	0.0%	0.0%	0.0%	45.1%	41.7%	13.2%	0.0%	0.0%	0.0%	0.0%	0.0%	66.2%	33.8%	0.0%	0.0%	0.0%	0.0%	0.0%	
% Total	2.7%	14.6%	1.2%	0.0%	18.4%	0.0%	0.0%	0.9%	24.3%	0.1%	0.0%	25.6%	0.0%	0.0%	0.5%	13.7%	7.8%	0.0%	23.1%	0.0%	0.0%	9.7%	20.7%	2.5%	0.0%	32.8%	0.0%	0.0%	0.0%	
PHF	0.712	0.785	0.444	0.000	0.765	0.000	0.000	0.813	0.882	0.500	0.000	0.901	0.000	0.000	0.583	0.775	0.743	0.000	0.827	0.000	0.000	0.831	0.713	0.531	0.000	0.769	0.000	0.000	0.846	
Lights	36	189	12	0	237	0	0	10	317	1	0	328	0	0	7	169	103	0	279	0	0	133	274	34	0	441	0	0	1285	
% Lights	87.3%	94.0%	75.0%	0.0%	93.3%	0.0%	0.0%	76.9%	94.6%	50.0%	0.0%	92.9%	0.0%	0.0%	100.0%	89.4%	96.3%	0.0%	87.5%	0.0%	0.0%	100.0%	96.1%	100.0%	0.0%	97.6%	0.0%	0.0%	93.3%	
Trucks	0	0	0	0	0	0	0	1	1	0	0	2	0	0	0	1	1	0	2	0	0	0	4	0	0	4	0	0	8	
% Trucks	0.0%	0.0%	0.0%	0.0%	0.0%	0.0%	0.0%	7.7%	0.3%	0.0%	0.0%	0.6%	0.0%	0.0%	0.0%	0.5%	0.9%	0.0%	0.6%	0.0%	0.0%	0.0%	1.4%	0.0%	0.0%	0.9%	0.0%	0.0%	0.6%	
Buses	1	12	4	0	17	0	0	2	17	1	0	20	0	0	0	19	3	0	22	0	0	0	7	0	0	7	0	0	66	
% Buses	2.7%	6.0%	25.0%	0.0%	6.0%	0.0%	0.0%	15.4%	5.1%	50.0%	0.0%	5.0%	0.0%	0.0%	0.0%	10.1%	2.8%	0.0%	6.0%	0.0%	0.0%	0.0%	2.5%	0.0%	0.0%	0.0%	0.0%	0.0%	4.8%	
Pedestrians	0	0	0	0	0	6	3	0	0	0	0	0	5	11	0	0	0	0	0	3	8	0	0	0	0	0	0	1	0	
% Pedestrians	0.0%	0.0%	0.0%	0.0%	0.0%	100.0%	100.0%	0.0%	0.0%	0.0%	0.0%	0.0%	100.0%	100.0%	0.0%	0.0%	0.0%	0.0%	0.0%	0.9%	100.0%	100.0%	0.0%	0.0%	0.0%	0.0%	0.0%	0.0%	100.0%	0.0%
Bicycles on Crosswalk	0	0	0	0	0	0	0	0	0	0	0	0	0	0	0	0	0	0	0	0	0	0	0	0	0	0	0	0	0	
% Bicycles on Crosswalk	0.0%	0.0%	0.0%	0.0%	0.0%	0.0%	0.0%	0.0%	0.0%	0.0%	0.0%	0.0%	0.0%	0.0%	0.0%	0.0%	0.0%	0.0%	0.0%	0.0%	0.0%	0.0%	0.0%	0.0%	0.0%	0.0%	0.0%	0.0%	0.0%	

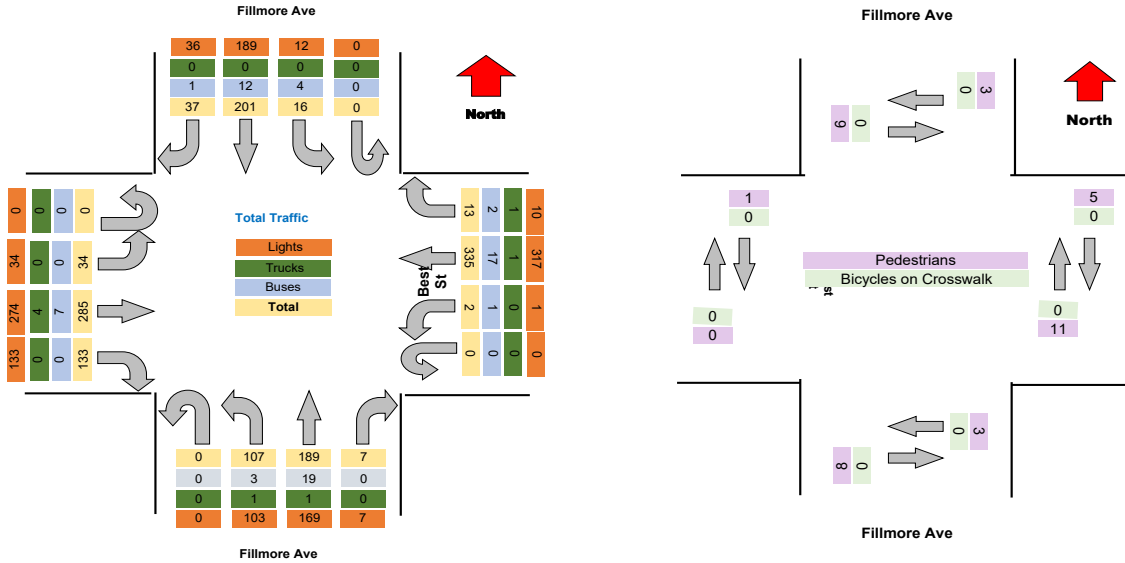

Turning Movement Peak Hour Data (PM)

4:30:00 PM

Leg Direction	Fillmore Ave										Best St				Fillmore Ave										Best St				Total
	Southbound					Westbound					Northbound					Eastbound													
	Right	Thru	Left	U-Turn	App Total	Right	Thru	Left	U-Turn	App Total	Right	Thru	Left	U-Turn	App Total	Right	Thru	Left	U-Turn	App Total									
4:30:00 PM	13	61	7	0	81	6	102	0	0	108	0	55	45	0	100	32	108	10	0	150									
4:45:00 PM	9	58	15	0	82	4	94	0	0	98	3	68	43	0	114	2	2	3	0	144									
5:00:00 PM	7	46	14	0	67	12	80	0	0	92	1	50	26	0	77	26	110	6	0	142									
5:15:00 PM	46	65	8	0	119	6	86	1	0	93	1	56	33	0	90	33	100	11	0	144									
Grand Total	45	239	44	0	319	28	372	1	0	401	5	229	147	0	381	129	419	34	0	580									
% Approach	14.1%	72.1%	13.8%	0.0%	0.0%	14.2%	85.6%	0.0%	0.0%	0.0%	45.1%	41.7%	13.2%	0.0%	0.0%	0.0%	66.2%	33.8%	0.0%	0.0%									
% Total	2.7%	13.7%	2.6%	0.0%	19.0%	1.7%	22.1%	0.1%	0.0%	23.9%	0.3%	13.6%	8.7%	0.0%	22.7%	7.6%	24.9%	2.0%	0.0%	34.5%									
PHF	0.703	0.885	0.733	0.000	0.896	0.583	0.912	0.250	0.000	0.928	0.417	0.842	0.817	0.000	0.836	0.865	0.950	0.773	0.000	0.967									
Lights	45	217	44	0	306	28	366	1	0	395	5	213	144	0	362	123	393	32	0	548									
% Lights	100.0%	94.3%	100.0%	0.0%	95.9%	100.0%	98.4%	100.0%	0.0%	98.5%	100.0%	93.0%	98.0%	0.0%	95.0%	96.1%	94.0%	94.1%	0.0%	94.5%									
Trucks	0	1	0	0	1	0	1	0	0	1	0	0	1	0	1	2	1	0	0	3									
% Trucks	0.0%	0.4%	0.0%	0.0%	0.3%	0.0%	0.3%	0.0%	0.0%	0.2%	0.0%	0.0%	0.7%	0.0%	0.3%	1.6%	0.2%	0.0%	0.0%	0.5%									
Buses	0	12	0	0	12	0	4	0	0	4	0	9	1	0	10	2	22	2	0	26									
% Buses	0.0%	5.2%	0.0%	0.0%	0.0%	0.0%	1.1%	0.0%	0.0%	0.0%	0.0%	3.9%	0.7%	0.0%	0.0%	1.6%	5.3%	5.9%	0.0%	0.0%									
Pedestrians	0	0	0	0	0	4	2	0	0	6	0	0	0	0	0	0	0	0	0	0									
% Pedestrians	0.0%	0.0%	0.0%	0.0%	0.0%	100.0%	100.0%	0.0%	0.0%	0.0%	0.0%	0.0%	0.0%	0.0%	0.0%	0.0%	0.0%	0.0%	0.0%	0.0%									
Bicycles on Crosswalk	0	0	0	0	0	0	0	0	0	0	1	3	0	0	4	0	0	0	0	0									
% Bicycles on Crosswalk	0.0%	0.0%	0.0%	0.0%	0.0%	0.0%	0.0%	0.0%	0.0%	0.0%	0.0%	0.0%	0.0%	0.0%	0.0%	0.0%	0.0%	0.0%	0.0%	0.0%									

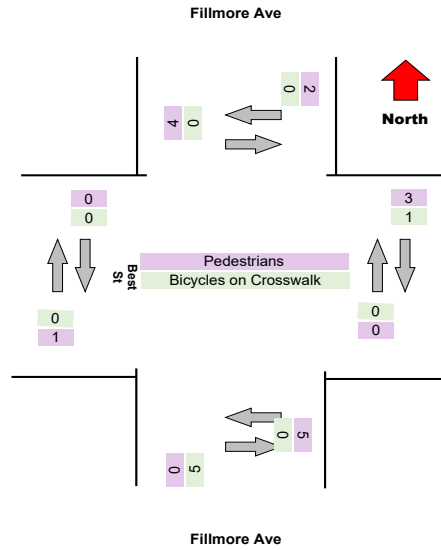
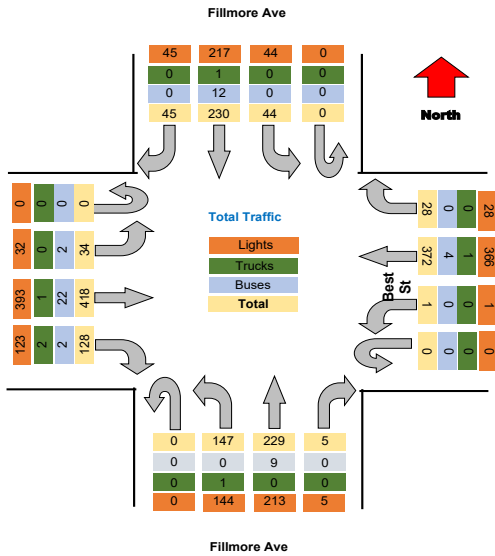

Project	Labella
Project Code	Labella
Site Name	17
Legs and Movements	All Processed Legs & Movements
Bin Size	15 minutes
Survey Date	2021-10-26, Tuesday
Location	17
Latitude and Longitude	42.903886, -78.839296

	Start	End	PHF
Forced Peak AM	2021/10/26 07:30:00	2021/10/26 08:30:00	0.898
Forced Peak PM	2021/10/26 16:30:00	2021/10/26 17:30:00	0.875
AM Peak	2021/10/26 07:30:00	2021/10/26 08:30:00	0.898
PM Peak	2021/10/26 16:30:00	2021/10/26 17:30:00	0.875

Turning Movement Data

Leg Direction	Fillmore Ave Southbound						Fillmore Ave NorthBound						Humboldt Pkwy S Eastbound					
	Right	Thru	U-Turn	App Total	Peds CW	Peds CCW	Thru	Left	U-Turn	App Total	Peds CW	Peds CCW	Right	Left	U-Turn	App Total	Peds CW	
6:30:00 AM	0	28	0	28	0	1	15	0	0	16	0	0	0	0	0	0	0	
6:45:00 AM	0	17	0	17	0	0	21	0	0	21	0	0	0	0	0	0	0	
Hourly Total	0	45	0	45	0	1	36	0	0	37	0	0	0	0	0	0	0	
7:00:00 AM	0	23	0	23	0	0	35	0	0	35	0	0	1	0	0	1	1	
7:15:00 AM	0	41	1	42	0	0	46	0	0	46	2	0	0	1	0	3	1	
7:30:00 AM	0	42	0	42	0	0	51	0	0	51	2	0	0	1	0	3	0	
7:45:00 AM	0	64	0	64	0	0	47	0	0	47	1	0	1	1	0	3	0	
Hourly Total	0	170	1	171	0	0	179	0	0	179	5	0	2	3	0	10	2	
8:00:00 AM	0	68	0	68	1	0	57	0	0	57	0	0	1	2	0	3	0	
8:15:00 AM	0	65	0	65	0	0	50	0	0	50	0	0	3	3	1	7	0	
Hourly Total	0	133	0	133	1	0	107	0	0	107	0	0	4	5	1	10	0	
4:00:00 PM	0	80	0	80	0	0	73	0	0	73	2	0	0	2	0	2	2	
4:15:00 PM	1	70	0	71	0	0	63	0	0	63	0	0	0	1	0	1	0	
4:30:00 PM	0	71	0	71	0	0	80	0	0	80	0	0	2	3	0	5	1	
4:45:00 PM	0	83	0	83	0	0	80	0	0	80	0	0	0	1	0	1	1	
Hourly Total	1	304	0	305	0	0	296	0	0	296	2	0	2	7	0	9	4	
5:00:00 PM	0	68	0	68	0	0	63	1	0	64	0	0	1	2	2	5	1	
5:15:00 PM	0	50	0	50	1	0	63	0	0	63	0	0	1	3	0	4	0	
5:30:00 PM	0	65	0	65	0	0	56	0	0	56	0	0	0	1	0	1	0	
5:45:00 PM	0	61	0	61	0	0	51	0	0	51	0	0	3	2	0	5	0	
Hourly Total	0	244	0	244	1	0	233	1	0	234	0	0	5	8	2	15	1	
Grand Total	1	896	1	898	2	1	851	1	0	853	7	0	13	23	3	44	7	
% Approach	0.1%	99.8%	0.1%	0.0%	0.0%	0.0%	99.8%	0.1%	0.0%	0.0%	0.0%	0.0%	29.5%	52.3%	6.8%	0.0%	0.0%	
% Total	0.1%	49.9%	0.1%	50.0%	0.0%	0.0%	47.4%	0.1%	0.0%	47.5%	0.0%	0.0%	0.7%	1.3%	0.2%	2.5%	0.0%	
Lights	1	847	1	849	0	0	782	1	0	783	0	0	12	23	3	38	0	
% Lights	100.0%	94.5%	100.0%	94.5%	0.0%	0.0%	91.9%	100.0%	0.0%	91.8%	0.0%	0.0%	92.3%	100.0%	100.0%	86.4%	0.0%	
Trucks	0	2	0	2	0	0	4	0	0	4	0	0	0	0	0	0	0	
% Trucks	0.0%	0.2%	0.0%	0.2%	0.0%	0.0%	0.5%	0.0%	0.0%	0.5%	0.0%	0.0%	0.0%	0.0%	0.0%	0.0%	0.0%	
Buses	0	47	0	47	0	0	65	0	0	65	0	0	1	0	0	1	0	
% Buses	0.0%	5.2%	0.0%	0.0%	0.0%	0.0%	0.0%	0.0%	0.0%	0.0%	0.0%	0.0%	7.7%	0.0%	0.0%	0.0%	0.0%	
Pedestrians	0	0	0	0	2	1	0	0	0	0	7	0	0	0	0	0	7	
% Pedestrians	0.0%	0.0%	0.0%	0.0%	100.0%	100.0%	0.0%	0.0%	0.0%	0.0%	100.0%	0.0%	0.0%	0.0%	0.0%	0.0%	100.0%	
% Bicycles on Crosswalk	0.0%	0.0%	0.0%	0.0%	0.0%	0.0%	0.0%	0.0%	0.0%	0.0%	0.0%	0.0%	0.0%	0.0%	0.0%	0.0%	0.0%	

Turning Movement Peak Hour Data (AM)

7:30:00 AM

Leg Direction	Fillmore Ave Southbound						Fillmore Ave NorthBound						Humboldt Pkwy S Eastbound					
	Right	Thru	U-Turn	App Total	Peds CW	Peds CCW	Thru	Left	U-Turn	App Total	Peds CW	Peds CCW	Right	Left	U-Turn	App Total	Peds CW	
7:30:00 AM	0	42	0	42	0	0	51	0	0	51	2	0	0	1	1	0	3	0
7:45:00 AM	0	64	0	64	0	0	47	0	0	47	1	0	1	1	0	3	0	0
8:00:00 AM	0	68	0	68	1	0	57	0	0	57	0	0	1	2	0	3	0	0
8:15:00 AM	0	65	0	65	0	0	50	0	0	50	0	0	3	3	1	7	0	0
Grand Total	0	239	0	239	1	0	205	0	0	205	3	0	5	7	1	16	0	0
% Approach	0.0%	100.0%	0.0%	0.0%	0.0%	0.0%	14.2%	0.0%	0.0%	0.0%	0.0%	0.0%	45.1%	41.7%	0.0%	0.0%	0.0%	0.0%
% Total	0.0%	52.0%	0.0%	52.0%	0.0%	0.0%	44.6%	0.0%	0.0%	44.6%	0.0%	0.0%	1.1%	1.5%	0.2%	3.5%	0.0%	0.0%
PHF	0.000	0.879	0.000	0.879	0.000	0.000	0.899	0.000	0.000	0.899	0.000	0.000	0.417	0.583	0.250	0.571	0.000	0.000
Lights	0	224	0	224	0	0	185	0	0	185	0	0	4	7	1	12	0	0
% Lights	0.0%	93.7%	0.0%	93.7%	0.0%	0.0%	90.2%	0.0%	0.0%	90.2%	0.0%	0.0%	80.0%	100.0%	100.0%	75.0%	0.0%	0.0%
Trucks	0	0	0	0	0	0	2	0	0	2	0	0	0	0	0	0	0	0
% Trucks	0.0%	0.0%	0.0%	0.0%	0.0%	0.0%	1.0%	0.0%	0.0%	1.0%	0.0%	0.0%	0.0%	0.0%	0.0%	0.0%	0.0%	0.0%
Buses	0	15	0	15	0	0	18	0	0	18	0	0	1	0	0	1	0	0
% Buses	0.0%	6.3%	0.0%	6.3%	0.0%	0.0%	8.8%	0.0%	0.0%	8.8%	0.0%	0.0%	20.0%	0.0%	0.0%	6.3%	0.0%	0.0%
Pedestrians	0	0	0	0	1	0	0	0	0	0	3	0	0	0	0	0	0	0
% Pedestrians	0.0%	0.0%	0.0%	0.0%	100.0%	0.0%	0.0%	0.0%	0.0%	100.0%	0.0%	0.0%	0.0%	0.0%	0.0%	0.0%	0.0%	0.0%
Bicycles on Crosswalk	0	0	0	0	0	0	0	0	0	0	0	0	0	0	0	0	0	0
% Bicycles on Crosswalk	0.0%	0.0%	0.0%	0.0%	0.0%	0.0%	0.0%	0.0%	0.0%	0.0%	0.0%	0.0%	0.0%	0.0%	0.0%	0.0%	0.0%	0.0%

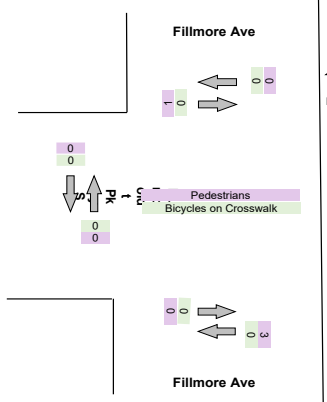
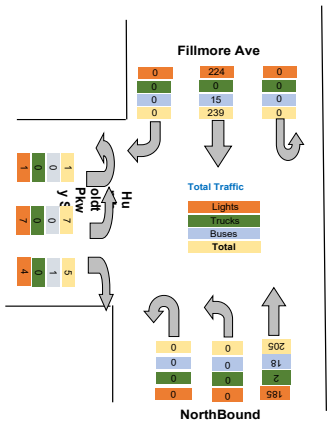

Turning Movement Peak Hour Data (PM)

4:30:00 PM

Leg Direction	Fillmore Ave Southbound						Fillmore Ave Northbound						Humboldt Pkwy S Eastbound					
	Right	Thru	U-Turn	App Total	Peds CW	Peds CCW	Thru	Left	U-Turn	App Total	Peds CW	Peds CCW	Right	Left	U-Turn	App Total	Peds CW	
4:30:00 PM	0	71	0	71	0	0	80	0	0	80	0	0	2	3	0	5	1	
4:45:00 PM	0	83	0	83	0	0	80	0	0	80	0	0	0	1	0	1	1	
5:00:00 PM	0	68	0	68	0	0	63	1	0	64	0	0	1	2	2	5	1	
5:15:00 PM	0	50	0	50	1	0	63	0	0	63	0	0	1	3	0	4	0	
Grand Total	0	272	0	272	1	0	286	1	0	287	0	0	4	9	2	15	3	
% Approach	0.0%	100.0%	0.0%	0.0%	0.0%	0.0%	14.2%	0.0%	0.0%	0.0%	0.0%	0.0%	45.1%	41.7%	0.0%	0.0%	0.0%	
% Total	0.0%	47.4%	0.0%	47.4%	0.0%	0.0%	49.8%	0.2%	0.0%	50.0%	0.0%	0.0%	0.7%	1.6%	0.3%	2.6%	0.0%	
PHF	0.000	0.819	0.000	0.819	0.000	0.000	0.894	0.250	0.000	0.897	0.000	0.000	0.500	0.750	0.250	0.750	0.000	
Lights	0	261	0	261	0	0	270	1	0	271	0	0	4	9	2	15	0	
% Lights	0.0%	96.0%	0.0%	96.0%	0.0%	0.0%	94.4%	100.0%	0.0%	94.4%	0.0%	0.0%	100.0%	100.0%	100.0%	100.0%	0.0%	
Trucks	0	1	0	1	0	0	1	0	0	1	0	0	0	0	0	0	0	
% Trucks	0.0%	0.4%	0.0%	0.4%	0.0%	0.0%	0.3%	0.0%	0.0%	0.3%	0.0%	0.0%	0.0%	0.0%	0.0%	0.0%	0.0%	
Buses	0	10	0	10	0	0	15	0	0	15	0	0	0	0	0	0	0	
% Buses	0.0%	3.7%	0.0%	3.7%	0.0%	0.0%	5.2%	0.0%	0.0%	5.2%	0.0%	0.0%	0.0%	0.0%	0.0%	0.0%	0.0%	
Pedestrians	0	0	0	0	1	0	0	0	0	0	0	0	0	0	0	0	3	
% Pedestrians	0.0%	0.0%	0.0%	0.0%	100.0%	0.0%	0.0%	0.0%	0.0%	0.0%	0.0%	0.0%	0.0%	0.0%	0.0%	0.0%	100.0%	
Bicycles on Crosswalk	0	0	0	0	0	0	0	0	0	0	0	0	0	0	0	0	0	
% Bicycles on Crosswalk	0.0%	0.0%	0.0%	0.0%	0.0%	0.0%	0.0%	0.0%	0.0%	0.0%	0.0%	0.0%	0.0%	0.0%	0.0%	0.0%	0.0%	

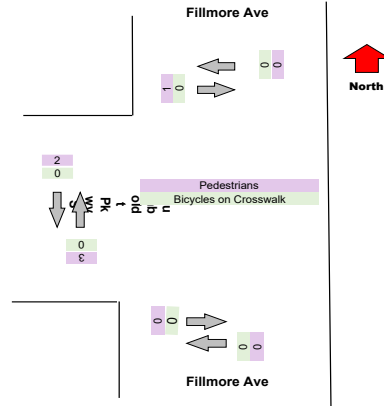
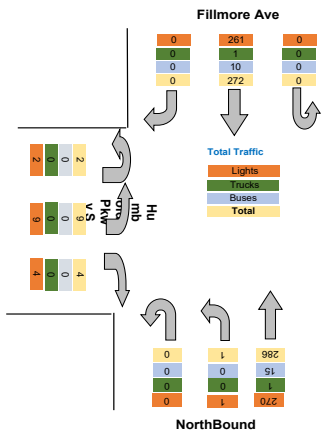

Intersection: Elm St Pine St
 Location: Kennett Square, PA
 Site: 01
 Survey Date: Wednesday, 04-28-2021
 GPS: 42.948550, -72.790034



Peds CCW	Total
1	44
0	38
1	82
0	59
0	91
0	96
0	114
0	360
0	128
0	122
0	250
0	155
0	135
1	156
1	164
2	610
0	137
0	117
0	122
0	117
0	493
3	1795
0.0%	0.0%
0.0%	0.0%
0	1670
0.0%	93.0%
0	6
0.0%	0.3%
0	113
0.0%	6.3%
3	0
100.0%	0.0%
0.0%	0.0%

Intersection: Elm St Pine St
 Location: Kennett Square, PA
 Site: 01
 Survey Date: Wednesday, 04-28-2021
 GPS: 42.948550, -72.790034



Peds CCW	Total
0	96
0	114
0	128
0	122
0	460
0.0%	
0.0%	
0.000	0.898
0	421
0.0%	91.5%
0	2
0.0%	0.4%
0	34
0.0%	7.4%
0	0
0.0%	0.0%
0	0
0.0%	0.0%

Intersection: Elm St Pine St
 Location: Kennett Square, PA
 Site: 01
 Survey Date: Wednesday, 04-28-2021
 GPS: 42.948550, -72.790034



Peds CCW	Total
1	156
1	164
0	137
0	117
2	574
0.0%	
0.0%	
0.000	0.875
0	547
0.0%	95.3%
0	2
0.0%	0.3%
0	25
0.0%	4.4%
2	0
100.0%	0.0%
0	0
0.0%	0.0%

Intersection: Elm St Pine St
 Location: Kennett Square, PA
 Site: 01
 Survey Date: Wednesday, 04-28-2021
 GPS: 42.948550, -72.790034



TSTData.com

Project	Labella
Project Code	Labella
Site Name	17
Legs and Movements	All Processed Legs & Movements
Bin Size	15 minutes
Survey Date	2021-10-27, Wednesday
Location	17
Latitude and Longitude	42.903886, -78.839296

	Start	End	PHF
Forced Peak AM	2021/10/27 07:30:00	2021/10/27 08:30:00	0.883
Forced Peak PM	2021/10/27 16:30:00	2021/10/27 17:30:00	0.902
AM Peak	2021/10/27 07:30:00	2021/10/27 08:30:00	0.883
PM Peak	2021/10/27 16:30:00	2021/10/27 17:30:00	0.902

Turning Movement Data

Leg Direction	Fillmore Ave Southbound						Fillmore Ave NorthBound						Humboldt Pkwy S Eastbound					
	Right	Thru	U-Turn	App Total	Peds CW	Peds CCW	Thru	Left	U-Turn	App Total	Peds CW	Peds CCW	Right	Left	U-Turn	App Total	Peds CW	Peds CCW
Start Time	0	22	0	22	0	0	14	0	0	14	0	0	0	0	0	0	0	0
6:30:00 AM	0	22	0	22	0	0	14	0	0	14	0	0	0	0	0	0	0	0
6:45:00 AM	0	30	0	30	0	1	30	0	0	31	0	0	0	0	0	0	0	0
Hourly Total	0	52	0	52	0	1	44	0	0	45	0	0	0	0	0	0	0	0
7:00:00 AM	0	36	0	36	0	0	27	0	0	27	0	0	0	0	0	0	0	0
7:15:00 AM	2	25	1	28	1	2	37	0	0	39	0	2	0	1	0	3	1	1
7:30:00 AM	1	40	0	41	0	1	47	0	0	48	0	1	1	1	0	3	0	0
7:45:00 AM	1	59	0	60	0	0	56	0	0	56	1	0	0	0	0	1	2	1
Hourly Total	4	160	1	165	1	3	167	0	0	170	1	3	1	2	0	7	3	2
8:00:00 AM	0	71	0	71	1	4	49	0	0	53	0	0	2	0	0	2	1	1
8:15:00 AM	0	61	0	61	0	0	48	0	0	48	0	0	1	0	0	1	0	0
Hourly Total	0	132	0	132	1	4	97	0	0	101	0	0	3	0	0	3	1	1
4:00:00 PM	0	107	0	107	1	2	72	0	0	72	2	0	2	5	0	7	0	3
4:15:00 PM	0	79	0	79	0	1	80	0	0	80	0	0	1	4	0	5	5	0
4:30:00 PM	0	64	0	64	1	0	85	0	0	85	4	0	2	1	0	3	5	3
4:45:00 PM	0	70	0	70	0	0	66	0	0	66	0	0	2	1	0	3	0	4
Hourly Total	0	320	0	320	2	3	303	0	0	303	6	0	7	11	0	18	10	10
5:00:00 PM	1	84	0	85	0	0	66	0	0	66	0	0	4	3	0	7	0	3
5:15:00 PM	0	60	0	60	0	0	61	0	0	61	0	0	0	0	0	0	2	3
5:30:00 PM	2	80	0	82	0	2	57	0	0	57	0	0	7	3	0	10	3	0
5:45:00 PM	0	47	0	47	0	0	48	0	0	48	1	1	0	3	0	3	0	1
Hourly Total	3	271	0	274	0	2	232	0	0	232	1	1	11	9	0	20	5	7
Grand Total	7	935	1	943	4	13	843	0	0	851	8	4	22	22	0	48	19	20
% Approach	0.7%	99.2%	0.1%	0.0%	0.0%	0.0%	99.1%	0.0%	0.0%	0.0%	0.0%	0.0%	45.8%	45.8%	0.0%	0.0%	0.0%	0.0%
% Total	0.4%	50.8%	0.1%	51.2%	0.0%	0.0%	45.8%	0.0%	0.0%	46.2%	0.0%	0.0%	1.2%	1.2%	0.0%	2.6%	0.0%	0.0%
Lights	7	876	1	884	0	0	770	0	0	770	0	0	22	22	0	44	0	0
% Lights	100.0%	93.7%	100.0%	93.7%	0.0%	0.0%	91.3%	0.0%	0.0%	90.5%	0.0%	0.0%	100.0%	100.0%	0.0%	91.7%	0.0%	0.0%
Trucks	0	1	0	1	0	0	3	0	0	3	0	0	0	0	0	0	0	0
% Trucks	0.0%	0.1%	0.0%	0.1%	0.0%	0.0%	0.4%	0.0%	0.0%	0.4%	0.0%	0.0%	0.0%	0.0%	0.0%	0.0%	0.0%	0.0%
Buses	0	55	0	55	0	0	68	0	0	68	0	0	0	0	0	0	0	0
% Buses	0.0%	5.9%	0.0%	0.0%	0.0%	0.0%	0.0%	0.0%	0.0%	0.0%	0.0%	0.0%	0.0%	0.0%	0.0%	0.0%	0.0%	0.0%
Pedestrians	0	0	0	0	4	13	0	0	0	0	8	4	0	0	0	0	17	15
% Pedestrians	0.0%	0.0%	0.0%	0.0%	100.0%	100.0%	0.0%	0.0%	0.0%	0.0%	100.0%	100.0%	0.0%	0.0%	0.0%	0.0%	89.5%	75.0%
% Bicycles on Crosswalk	0.0%	0.0%	0.0%	0.0%	0.0%	0.0%	0.0%	0.0%	0.0%	0.0%	0.0%	0.0%	0.0%	0.0%	0.0%	0.0%	10.5%	25.0%

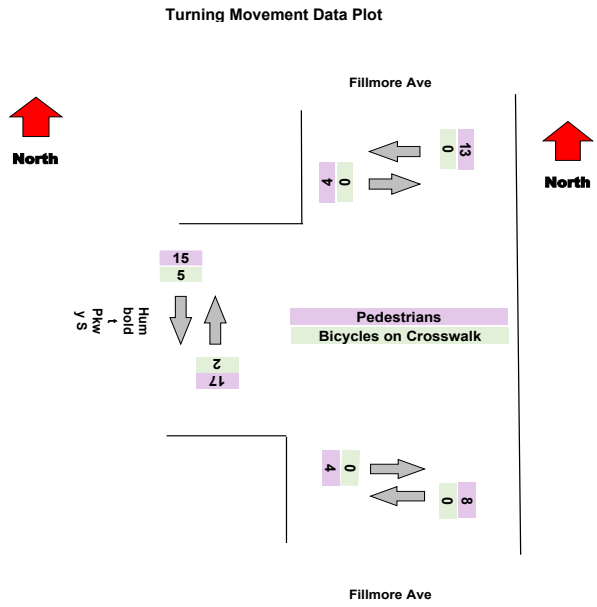
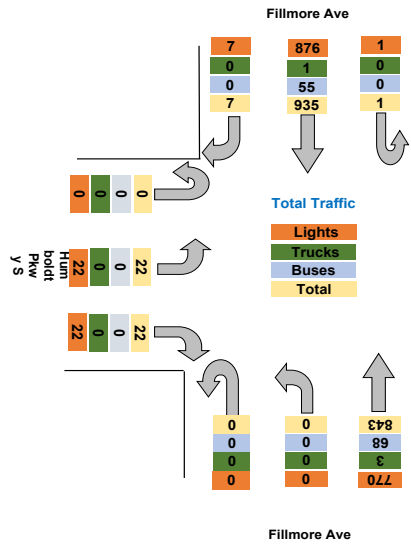

Turning Movement Peak Hour Data (AM)

7:30:00 AM

Leg Direction	Fillmore Ave Southbound						Fillmore Ave NorthBound						Humboldt Pkwy S Eastbound					
	Right	Thru	U-Turn	App Total	Peds CW	Peds CCW	Thru	Left	U-Turn	App Total	Peds CW	Peds CCW	Right	Left	U-Turn	App Total	Peds CW	Peds CCW
7:30:00 AM	1	40	0	41	0	1	47	0	0	48	0	1	1	1	0	3	0	0
7:45:00 AM	1	59	0	60	0	0	56	0	0	56	1	0	0	0	0	1	2	1
8:00:00 AM	0	71	0	71	1	4	49	0	0	53	0	0	2	0	0	2	1	1
8:15:00 AM	0	61	0	61	0	0	48	0	0	48	0	0	1	0	0	1	0	0
Grand Total	2	231	0	233	1	5	200	0	0	205	1	1	4	1	0	7	3	2
% Approach	0.9%	99.1%	0.0%	0.0%	0.0%	0.0%	14.2%	0.0%	0.0%	0.0%	0.0%	0.0%	45.1%	41.7%	0.0%	0.0%	0.0%	0.0%
% Total	0.4%	51.9%	0.0%	52.4%	0.0%	0.0%	44.9%	0.0%	0.0%	46.1%	0.0%	0.0%	0.9%	0.2%	0.0%	1.6%	0.0%	0.0%
PHF	0.500	0.813	0.000	0.820	0.000	0.000	0.893	0.000	0.000	0.915	0.000	0.000	0.500	0.250	0.000	0.583	0.000	0.000
Lights	2	209	0	211	0	0	178	0	0	178	0	0	4	1	0	5	0	0
% Lights	100.0%	90.5%	0.0%	90.6%	0.0%	0.0%	89.0%	0.0%	0.0%	86.8%	0.0%	0.0%	100.0%	100.0%	0.0%	71.4%	0.0%	0.0%
Trucks	0	0	0	0	0	0	1	0	0	1	0	0	0	0	0	0	0	0
% Trucks	0.0%	0.0%	0.0%	0.0%	0.0%	0.0%	0.5%	0.0%	0.0%	0.5%	0.0%	0.0%	0.0%	0.0%	0.0%	0.0%	0.0%	0.0%
Buses	0	21	0	21	0	0	21	0	0	21	0	0	0	0	0	0	0	0
% Buses	0.0%	9.1%	0.0%	0.0%	0.0%	0.0%	10.5%	0.0%	0.0%	0.0%	0.0%	0.0%	0.0%	0.0%	0.0%	0.0%	0.0%	0.0%
Pedestrians	0	0	0	0	1	5	0	0	0	0	1	1	0	0	0	0	2	1
% Pedestrians	0.0%	0.0%	0.0%	0.0%	100.0%	100.0%	0.0%	0.0%	0.0%	0.0%	100.0%	100.0%	0.0%	0.0%	0.0%	0.0%	66.7%	50.0%
Bicycles on Crosswalk	0	0	0	0	0	0	0	0	0	0	0	0	0	0	0	0	1	1
% Bicycles on Crosswalk	0.0%	0.0%	0.0%	0.0%	0.0%	0.0%	0.0%	0.0%	0.0%	0.0%	0.0%	0.0%	0.0%	0.0%	0.0%	0.0%	33.3%	50.0%

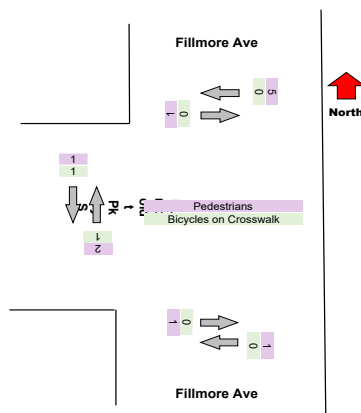
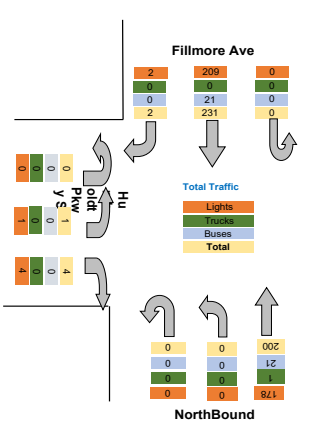

Turning Movement Peak Hour Data (PM)

4:30:00 PM

Leg Direction	Fillmore Ave Southbound						Fillmore Ave Northbound						Humboldt Pkwy S Eastbound					
	Right	Thru	U-Turn	App Total	Peds CW	Peds CCW	Thru	Left	U-Turn	App Total	Peds CW	Peds CCW	Right	Left	U-Turn	App Total	Peds CW	Peds CCW
4:30:00 PM	0	64	0	64	1	0	85	0	0	85	4	0	2	1	0	3	5	3
4:45:00 PM	0	70	0	70	0	0	66	0	0	66	0	0	2	1	0	3	0	4
5:00:00 PM	1	84	0	85	0	0	66	0	0	66	0	0	4	3	0	7	0	3
5:15:00 PM	0	60	0	60	0	0	61	0	0	61	0	0	0	0	0	0	2	3
Grand Total	1	278	0	279	1	0	278	0	0	278	4	0	8	5	0	13	7	13
% Approach	0.4%	99.6%	0.0%	0.0%	0.0%	0.0%	14.2%	0.0%	0.0%	0.0%	0.0%	0.0%	45.1%	41.7%	0.0%	0.0%	0.0%	0.0%
% Total	0.2%	48.8%	0.0%	48.9%	0.0%	0.0%	48.8%	0.0%	0.0%	48.8%	0.0%	0.0%	1.4%	0.9%	0.0%	2.3%	0.0%	0.0%
PHF	0.250	0.827	0.000	0.821	0.000	0.000	0.818	0.000	0.000	0.818	0.000	0.000	0.500	0.417	0.000	0.464	0.000	0.000
Lights	1	265	0	266	0	0	263	0	0	263	0	0	8	5	0	13	0	0
% Lights	100.0%	95.3%	0.0%	95.3%	0.0%	0.0%	94.6%	0.0%	0.0%	94.6%	0.0%	0.0%	100.0%	100.0%	0.0%	100.0%	0.0%	0.0%
Trucks	0	1	0	1	0	0	1	0	0	1	0	0	0	0	0	0	0	0
% Trucks	0.0%	0.4%	0.0%	0.4%	0.0%	0.0%	0.4%	0.0%	0.0%	0.4%	0.0%	0.0%	0.0%	0.0%	0.0%	0.0%	0.0%	0.0%
Buses	0	11	0	11	0	0	14	0	0	14	0	0	0	0	0	0	0	0
% Buses	0.0%	4.0%	0.0%	0.0%	0.0%	0.0%	5.0%	0.0%	0.0%	0.0%	0.0%	0.0%	0.0%	0.0%	0.0%	0.0%	0.0%	0.0%
Pedestrians	0	0	0	0	1	0	0	0	0	0	4	0	0	0	0	0	7	11
% Pedestrians	0.0%	0.0%	0.0%	0.0%	100.0%	0.0%	0.0%	0.0%	0.0%	0.0%	100.0%	0.0%	0.0%	0.0%	0.0%	0.0%	100.0%	84.6%
Bicycles on Crosswalk	0	0	0	0	0	0	0	0	0	0	0	0	0	0	0	0	0	2
% Bicycles on Crosswalk	0.0%	0.0%	0.0%	0.0%	0.0%	0.0%	0.0%	0.0%	0.0%	0.0%	0.0%	0.0%	0.0%	0.0%	0.0%	0.0%	0.0%	15.4%

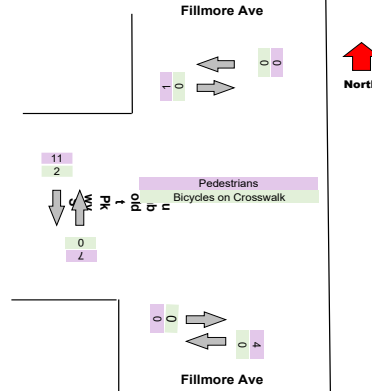
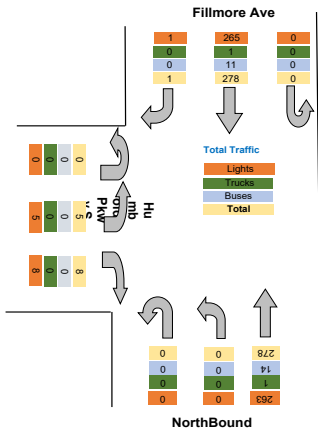

Intersection: Elm St Pine St
 Location: Kennett Square, PA
 Site: 01
 Survey Date: Wednesday, 04-28-2021
 GPS: 42.948550, -72.790034



Total
36
61
97
63
70
92
117
342
126
110
236
186
164
152
139
641
158
121
149
98
526
1842
0.0%
0.0%
1698
92.2%
4
0.2%
123
6.7%
0
0.0%
0.0%

Intersection: Elm St Pine St
Location: Kennett Square, PA
Site: 01
Survey Date: Wednesday, 04-28-2021
GPS: 42.948550, -72.790034



Total
92
117
126
110
445
0.883
394
88.5%
1
0.2%
42
9.4%
0
0.0%
0
0.0%

Intersection: Elm St Pine St
Location: Kennett Square, PA
Site: 01
Survey Date: Wednesday, 04-28-2021
GPS: 42.948550, -72.790034



Total
152
139
158
121
570
0.902
542
95.1%
2
0.4%
25
4.4%
0
0.0%
0
0.0%

Project	Labella
Project Code	Labella
Site Name	17
Legs and Movements	All Processed Legs & Movements
Bin Size	15 minutes
Survey Date	2021-10-28, Thursday
Location	17
Latitude and Longitude	42.903886, -78.839296

	Start	End	PHF
Forced Peak AM	2021/10/28 07:30:00	2021/10/28 08:30:00	0.828
Forced Peak PM	2021/10/28 16:30:00	2021/10/28 17:30:00	0.924
AM Peak	2021/10/28 07:30:00	2021/10/28 08:30:00	0.828
PM Peak	2021/10/28 16:30:00	2021/10/28 17:30:00	0.924

Turning Movement Data

Leg Direction	Fillmore Ave Southbound						Fillmore Ave NorthBound						Humboldt Pkwy S Eastbound					
	Right	Thru	U-Turn	App Total	Peds CW	Peds CCW	Thru	Left	U-Turn	App Total	Peds CW	Peds CCW	Right	Left	U-Turn	App Total	Peds CW	Peds CCW
Start Time																		
6:30:00 AM	0	15	0	15	0	0	13	0	0	13	0	0	0	0	0	0	0	0
6:45:00 AM	0	26	0	26	0	0	30	0	0	30	0	0	0	1	0	1	0	0
Hourly Total	0	41	0	41	0	0	43	0	0	43	0	0	0	1	0	1	0	0
7:00:00 AM	0	25	0	25	0	0	20	0	0	20	1	0	0	0	0	1	1	0
7:15:00 AM	0	33	0	33	0	0	33	0	0	33	0	0	0	0	0	0	1	1
7:30:00 AM	0	41	0	41	0	1	67	0	0	68	0	1	0	0	0	1	1	2
7:45:00 AM	0	60	0	60	2	0	58	0	0	58	1	1	1	2	0	5	0	0
Hourly Total	0	159	0	159	2	1	178	0	0	179	2	2	1	2	0	7	3	3
8:00:00 AM	2	80	0	82	1	0	66	0	0	66	0	3	1	2	0	6	2	1
8:15:00 AM	0	72	0	72	1	1	46	0	0	47	1	1	1	1	0	4	0	0
Hourly Total	2	152	0	154	2	1	112	0	0	113	1	4	2	3	0	10	2	1
4:00:00 PM	0	82	0	82	0	3	67	0	0	67	0	0	1	1	0	2	0	0
4:15:00 PM	0	80	0	80	0	0	75	0	0	75	1	0	1	3	0	4	0	1
4:30:00 PM	0	73	0	73	0	2	71	0	0	71	0	1	3	1	0	4	1	1
4:45:00 PM	0	80	0	80	2	0	79	0	0	79	0	0	1	1	0	2	4	5
Hourly Total	0	315	0	315	2	5	292	0	0	292	1	1	6	6	0	12	5	7
5:00:00 PM	0	68	0	68	0	0	68	0	0	68	0	0	0	5	0	5	0	0
5:15:00 PM	0	88	0	88	0	0	73	0	0	73	0	0	4	2	0	6	2	2
5:30:00 PM	0	80	0	80	0	0	68	0	0	68	0	0	3	1	0	4	0	2
5:45:00 PM	0	65	0	65	0	0	51	0	0	51	0	0	2	2	0	4	0	1
Hourly Total	0	301	0	301	0	0	260	0	0	260	0	0	9	10	0	19	2	5
Grand Total	2	968	0	970	6	7	885	0	0	887	4	7	18	22	0	49	12	16
% Approach	0.2%	99.8%	0.0%	0.0%	0.0%	0.0%	99.8%	0.0%	0.0%	0.0%	0.0%	0.0%	36.7%	44.9%	0.0%	0.0%	0.0%	0.0%
% Total	0.1%	50.8%	0.0%	50.9%	0.0%	0.0%	46.4%	0.0%	0.0%	46.5%	0.0%	0.0%	0.9%	1.2%	0.0%	2.6%	0.0%	0.0%
Lights	2	912	0	914	0	0	812	0	0	812	0	0	18	22	0	40	0	0
% Lights	100.0%	94.2%	0.0%	94.2%	0.0%	0.0%	91.8%	0.0%	0.0%	91.5%	0.0%	0.0%	100.0%	100.0%	0.0%	81.6%	0.0%	0.0%
Trucks	0	4	0	4	0	0	4	0	0	4	0	0	0	0	0	0	0	0
% Trucks	0.0%	0.4%	0.0%	0.4%	0.0%	0.0%	0.5%	0.0%	0.0%	0.5%	0.0%	0.0%	0.0%	0.0%	0.0%	0.0%	0.0%	0.0%
Buses	0	51	0	51	0	0	62	0	0	62	0	0	0	0	0	0	0	0
% Buses	0.0%	5.3%	0.0%	0.0%	0.0%	0.0%	0.0%	0.0%	0.0%	0.0%	0.0%	0.0%	0.0%	0.0%	0.0%	0.0%	0.0%	0.0%
Pedestrians	0	0	0	0	6	7	0	0	0	0	4	7	0	0	0	0	12	16
% Pedestrians	0.0%	0.0%	0.0%	0.0%	100.0%	100.0%	0.0%	0.0%	0.0%	0.0%	100.0%	100.0%	0.0%	0.0%	0.0%	0.0%	100.0%	100.0%
% Bicycles on Crosswalk	0.0%	0.0%	0.0%	0.0%	0.0%	0.0%	0.0%	0.0%	0.0%	0.0%	0.0%	0.0%	0.0%	0.0%	0.0%	0.0%	0.0%	0.0%

Turning Movement Data Plot

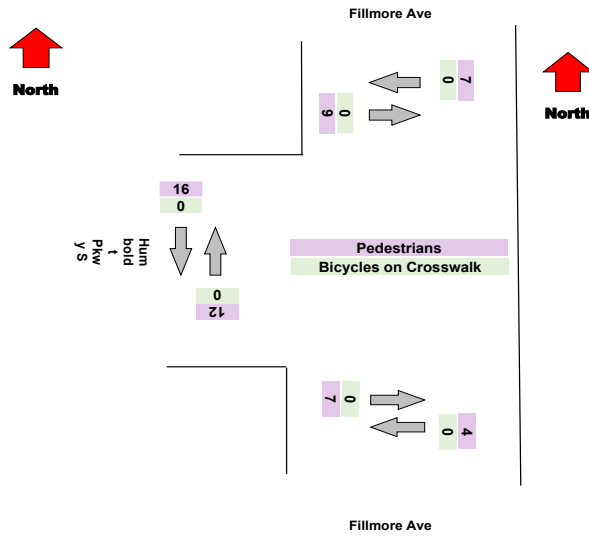
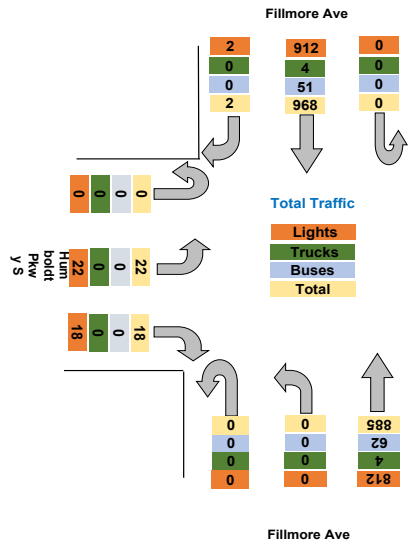

Turning Movement Peak Hour Data (AM)

7:30:00 AM

Leg Direction	Fillmore Ave Southbound						Fillmore Ave NorthBound						Humboldt Pkwy S Eastbound						
	Right	Thru	U-Turn	App Total	Peds CW	Peds CCW	Thru	Left	U-Turn	App Total	Peds CW	Peds CCW	Right	Left	U-Turn	App Total	Peds CW	Peds CCW	
7:30:00 AM	0	41	0	41	0	1	67	0	0	68	0	1	0	0	0	1	1	1	2
7:45:00 AM	0	60	0	60	2	0	58	0	0	58	1	1	1	2	0	5	0	0	0
8:00:00 AM	2	80	0	82	1	0	66	0	0	66	0	3	1	2	0	6	2	1	1
8:15:00 AM	0	72	0	72	1	1	46	0	0	47	1	1	1	1	0	4	0	0	0
Grand Total	2	253	0	255	4	2	237	0	0	239	2	6	3	5	0	16	3	3	3
% Approach	0.8%	99.2%	0.0%	0.0%	0.0%	0.0%	14.2%	0.0%	0.0%	0.0%	0.0%	0.0%	45.1%	41.7%	0.0%	0.0%	0.0%	0.0%	0.0%
% Total	0.4%	49.6%	0.0%	50.0%	0.0%	0.0%	46.5%	0.0%	0.0%	46.9%	0.0%	0.0%	0.6%	1.0%	0.0%	3.1%	0.0%	0.0%	0.0%
PHF	0.250	0.791	0.000	0.777	0.000	0.000	0.884	0.000	0.000	0.879	0.000	0.000	0.750	0.625	0.000	0.667	0.000	0.000	0.000
Lights	2	236	0	238	0	0	214	0	0	214	0	0	3	5	0	8	0	0	0
% Lights	100.0%	93.3%	0.0%	93.3%	0.0%	0.0%	90.3%	0.0%	0.0%	89.5%	0.0%	0.0%	100.0%	100.0%	0.0%	50.0%	0.0%	0.0%	0.0%
Trucks	0	0	0	0	0	0	2	0	0	2	0	0	0	0	0	0	0	0	0
% Trucks	0.0%	0.0%	0.0%	0.0%	0.0%	0.0%	0.8%	0.0%	0.0%	0.8%	0.0%	0.0%	0.0%	0.0%	0.0%	0.0%	0.0%	0.0%	0.0%
Buses	0	17	0	17	0	0	21	0	0	21	0	0	0	0	0	0	0	0	0
% Buses	0.0%	6.7%	0.0%	0.0%	0.0%	0.0%	8.9%	0.0%	0.0%	0.0%	0.0%	0.0%	0.0%	0.0%	0.0%	0.0%	0.0%	0.0%	0.0%
Pedestrians	0	0	0	0	4	2	0	0	0	2	6	0	0	0	0	3	3	3	3
% Pedestrians	0.0%	0.0%	0.0%	0.0%	100.0%	100.0%	0.0%	0.0%	0.0%	0.0%	100.0%	100.0%	0.0%	0.0%	0.0%	0.0%	100.0%	100.0%	100.0%
Bicycles on Crosswalk	0	0	0	0	0	0	0	0	0	0	0	0	0	0	0	0	0	0	0
% Bicycles on Crosswalk	0.0%	0.0%	0.0%	0.0%	0.0%	0.0%	0.0%	0.0%	0.0%	0.0%	0.0%	0.0%	0.0%	0.0%	0.0%	0.0%	0.0%	0.0%	0.0%

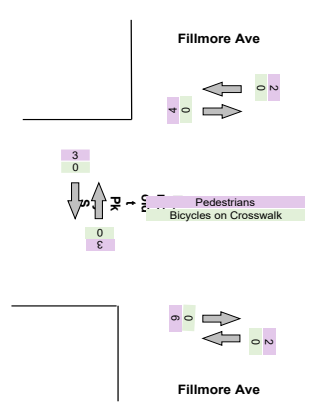
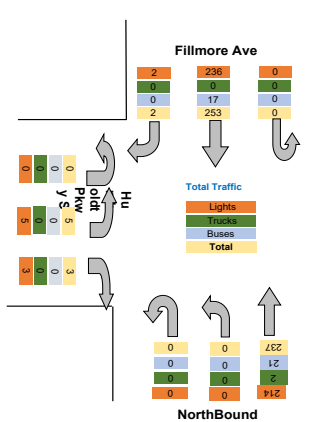

Turning Movement Peak Hour Data (PM)

4:30:00 PM

Leg Direction	Fillmore Ave Southbound						Fillmore Ave NorthBound						Humboldt Pkwy S Eastbound					
	Right	Thru	U-Turn	App Total	Peds CW	Peds CCW	Thru	Left	U-Turn	App Total	Peds CW	Peds CCW	Right	Left	U-Turn	App Total	Peds CW	Peds CCW
4:30:00 PM	0	73	0	73	0	2	71	0	0	71	0	1	3	1	0	4	1	1
4:45:00 PM	0	80	0	80	2	0	79	0	0	79	0	0	1	1	0	2	4	5
5:00:00 PM	0	68	0	68	0	0	68	0	0	68	0	0	0	5	0	5	0	0
5:15:00 PM	0	88	0	88	0	0	73	0	0	73	0	0	4	2	0	6	2	2
Grand Total	0	309	0	309	2	2	291	0	0	291	0	1	8	9	0	17	7	8
% Approach	0.0%	100.0%	0.0%	0.0%	0.0%	0.0%	14.2%	0.0%	0.0%	0.0%	0.0%	0.0%	45.1%	41.7%	0.0%	0.0%	0.0%	0.0%
% Total	0.0%	50.1%	0.0%	50.1%	0.0%	0.0%	47.2%	0.0%	0.0%	47.2%	0.0%	0.0%	1.3%	1.5%	0.0%	2.8%	0.0%	0.0%
PHF	0.000	0.878	0.000	0.878	0.000	0.000	0.921	0.000	0.000	0.921	0.000	0.000	0.500	0.450	0.000	0.708	0.000	0.000
Lights	0	295	0	295	0	0	273	0	0	273	0	0	8	9	0	17	0	0
% Lights	0.0%	95.5%	0.0%	95.5%	0.0%	0.0%	93.8%	0.0%	0.0%	93.8%	0.0%	0.0%	100.0%	100.0%	0.0%	100.0%	0.0%	0.0%
Trucks	0	1	0	1	0	0	0	0	0	0	0	0	0	0	0	0	0	0
% Trucks	0.0%	0.3%	0.0%	0.3%	0.0%	0.0%	0.0%	0.0%	0.0%	0.0%	0.0%	0.0%	0.0%	0.0%	0.0%	0.0%	0.0%	0.0%
Buses	0	13	0	13	0	0	11	0	0	11	0	0	0	0	0	0	0	0
% Buses	0.0%	4.2%	0.0%	4.2%	0.0%	0.0%	3.8%	0.0%	0.0%	3.8%	0.0%	0.0%	0.0%	0.0%	0.0%	0.0%	0.0%	0.0%
Pedestrians	0	0	0	0	2	2	0	0	0	0	0	1	0	0	0	0	7	8
% Pedestrians	0.0%	0.0%	0.0%	0.0%	100.0%	100.0%	0.0%	0.0%	0.0%	0.0%	0.0%	100.0%	0.0%	0.0%	0.0%	0.0%	100.0%	100.0%
Bicycles on Crosswalk	0	0	0	0	0	0	0	0	0	0	0	0	0	0	0	0	0	0
% Bicycles on Crosswalk	0.0%	0.0%	0.0%	0.0%	0.0%	0.0%	0.0%	0.0%	0.0%	0.0%	0.0%	0.0%	0.0%	0.0%	0.0%	0.0%	0.0%	0.0%

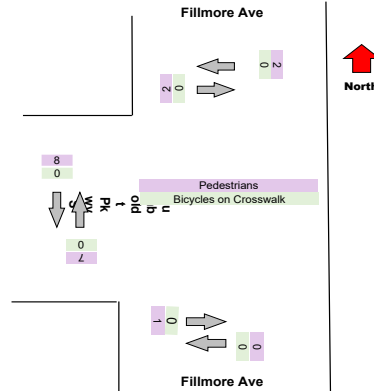
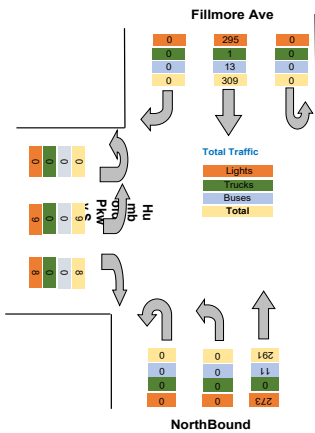

Intersection: Elm St Pine St
 Location: Kennett Square, PA
 Site: 01
 Survey Date: Wednesday, 04-28-2021
 GPS: 42.948550, -72.790034



Total
28
57
85
46
66
110
123
345
154
123
277
151
159
148
161
619
141
167
152
120
580
1906
0.0%
0.0%
1766
92.7%
8
0.4%
113
5.9%
0
0.0%
0.0%

Intersection: Elm St Pine St
Location: Kennett Square, PA
Site: 01
Survey Date: Wednesday, 04-28-2021
GPS: 42.948550, -72.790034



Total
110
123
154
123
510
0.828
460
90.2%
2
0.4%
38
7.5%
0
0.0%
0
0.0%

Intersection: Elm St Pine St
Location: Kennett Square, PA
Site: 01
Survey Date: Wednesday, 04-28-2021
GPS: 42.948550, -72.790034



Total
148
161
141
167
617
0.924
586
94.8%
1
0.2%
24
3.9%
0
0.0%
0
0.0%

Project	LaBella
Project Code	LaBella
Site Name	18
Legs and Movements	All Processed Legs & Movements
Bin Size	15 minutes
Survey Date	2021-11-02, Tuesday
Location	18
Latitude and Longitude	42.905776, -78.839064

	Start	End	PHF
Forced Peak AM	2021/11/02 07:30:00	2021/11/02 08:30:00	0.92
Forced Peak PM	2021/11/02 16:30:00	2021/11/02 17:30:00	0.938
AM Peak	2021/11/02 07:30:00	2021/11/02 08:30:00	0.92
PM Peak	2021/11/02 16:15:00	2021/11/02 17:15:00	0.966

Turning Movement Data

Leg Direction	Fillmore Ave Southbound						Fillmore Ave NorthBound						Martin Luther King Park Eastbound									
	Right	Thru	U-Turn	App	Total	Peds CW	Peds CCW	Thru	Left	U-Turn	App	Total	Peds CW	Peds CCW	Right	Left	U-Turn	App	Total	Peds CW		
Start Time																						
6:30:00 AM	1	14	1	16	0	0	0	17	1	0	18	0	0	0	0	0	0	0	0	0	0	1
6:45:00 AM	0	25	0	25	0	0	0	24	2	0	26	1	0	0	2	0	0	0	3	1	0	0
Hourly Total	1	39	1	41	0	0	0	41	3	0	44	1	0	0	2	0	0	0	3	2	0	0
7:00:00 AM	0	25	0	25	1	0	0	27	2	0	29	0	3	0	4	0	0	0	7	0	0	0
7:15:00 AM	0	23	0	23	0	0	0	30	1	0	31	2	0	0	2	0	0	0	4	0	0	0
7:30:00 AM	0	31	0	31	0	0	0	30	0	0	30	0	0	0	0	0	0	0	0	1	0	0
7:45:00 AM	0	31	0	31	0	0	0	35	0	0	35	0	0	0	0	0	0	0	0	0	0	0
Hourly Total	0	110	0	110	1	0	0	122	3	0	125	2	3	0	6	0	0	0	11	1	0	0
8:00:00 AM	0	37	0	37	0	0	0	25	0	0	25	1	0	0	3	0	0	0	4	0	0	0
8:15:00 AM	0	42	0	42	0	0	0	27	0	0	27	0	1	0	2	0	0	0	3	0	0	0
Hourly Total	0	79	0	79	0	0	0	52	0	0	52	1	1	0	5	0	0	0	7	0	0	0
4:00:00 PM	0	67	0	67	0	0	0	57	0	0	57	1	0	0	5	1	0	0	6	0	0	0
4:15:00 PM	0	63	0	63	0	0	0	67	0	0	67	0	1	0	0	1	0	0	1	0	0	0
4:30:00 PM	0	57	0	57	0	0	0	67	0	0	67	0	0	0	1	2	0	0	3	1	0	0
4:45:00 PM	0	53	0	53	0	0	0	65	0	0	65	0	0	0	1	1	0	0	2	0	0	0
Hourly Total	0	240	0	240	0	0	0	256	0	0	256	1	1	0	7	5	0	0	12	1	0	0
5:00:00 PM	0	63	0	63	0	0	0	66	0	0	66	0	0	0	2	1	0	0	3	0	0	0
5:15:00 PM	0	45	0	45	0	0	0	66	0	0	66	0	0	0	4	1	0	0	5	1	0	0
5:30:00 PM	0	60	0	60	0	0	0	42	0	0	42	0	0	0	6	2	0	0	8	0	0	0
5:45:00 PM	1	48	0	49	0	0	0	48	0	0	48	0	0	0	8	2	0	0	10	1	0	0
Hourly Total	1	216	0	217	0	0	0	222	0	0	222	0	0	0	20	6	0	0	26	2	0	0
Grand Total	2	684	1	687	1	0	0	693	6	0	699	5	5	0	40	11	0	0	59	5	0	0
% Approach	0.3%	99.6%	0.1%	0.0%	0.0%	0.0%	0.0%	99.1%	0.9%	0.0%	0.0%	0.0%	0.0%	0.0%	67.8%	18.6%	0.0%	0.0%	0.0%	0.0%	0.0%	0.0%
% Total	0.1%	47.3%	0.1%	47.5%	0.0%	0.0%	0.0%	48.0%	0.4%	0.0%	48.4%	0.0%	0.0%	0.0%	2.8%	0.8%	0.0%	0.0%	4.1%	0.0%	0.0%	0.0%
Lights	2	660	1	663	0	0	0	671	6	0	677	0	0	0	40	11	0	0	51	0	0	0
% Lights	100.0%	96.5%	100.0%	96.5%	0.0%	0.0%	0.0%	96.8%	100.0%	0.0%	96.9%	0.0%	0.0%	0.0%	100.0%	100.0%	0.0%	0.0%	86.4%	0.0%	0.0%	0.0%
Trucks	0	2	0	2	0	0	0	3	0	0	3	0	0	0	0	0	0	0	0	0	0	0
% Trucks	0.0%	0.3%	0.0%	0.3%	0.0%	0.0%	0.0%	0.4%	0.0%	0.0%	0.4%	0.0%	0.0%	0.0%	0.0%	0.0%	0.0%	0.0%	0.0%	0.0%	0.0%	0.0%
Buses	0	22	0	22	0	0	0	19	0	0	19	0	0	0	0	0	0	0	0	0	0	0
% Buses	0.0%	3.2%	0.0%	0.0%	0.0%	0.0%	0.0%	0.0%	0.0%	0.0%	0.0%	0.0%	0.0%	0.0%	0.0%	0.0%	0.0%	0.0%	0.0%	0.0%	0.0%	0.0%
Pedestrians	0	0	0	0	1	0	0	0	0	0	0	5	5	0	0	0	0	0	0	5	0	0
% Pedestrians	0.0%	0.0%	0.0%	0.0%	100.0%	0.0%	0.0%	0.0%	0.0%	0.0%	0.0%	100.0%	100.0%	0.0%	0.0%	0.0%	0.0%	0.0%	0.0%	83.3%	0.0%	0.0%
Bicycles on Crosswalk	0	0	0	0	0	0	0	0	0	0	0	0	0	0	0	0	0	0	0	1	0	0
% Bicycles on Crosswalk	0.0%	0.0%	0.0%	0.0%	0.0%	0.0%	0.0%	0.0%	0.0%	0.0%	0.0%	0.0%	0.0%	0.0%	0.0%	0.0%	0.0%	0.0%	0.0%	16.7%	0.0%	0.0%

Turning Movement Data Plot

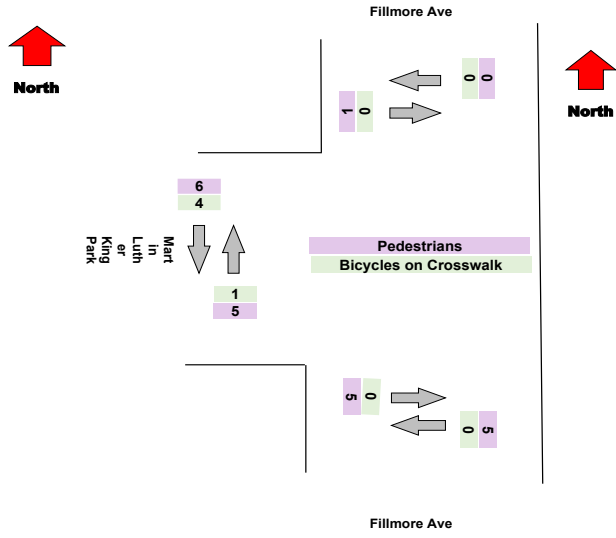
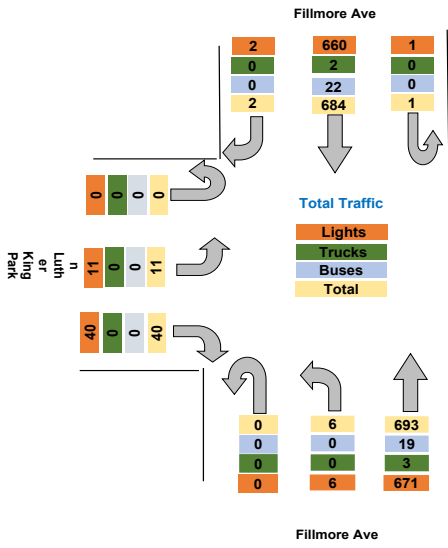

Turning Movement Peak Hour Data (AM)

7:30:00 AM

Leg Direction	Fillmore Ave Southbound						Fillmore Ave NorthBound						Martin Luther King Park Eastbound				
	Right	Thru	U-Turn	App Total	Peds CW	Peds CCW	Thru	Left	U-Turn	App Total	Peds CW	Peds CCW	Right	Left	U-Turn	App Total	Peds CW
Start Time																	
7:30:00 AM	0	31	0	31	0	0	30	0	0	30	0	0	0	0	0	0	1
7:45:00 AM	0	31	0	31	0	0	35	0	0	35	0	0	0	0	0	0	0
8:00:00 AM	0	37	0	37	0	0	25	0	0	25	1	0	3	0	0	4	0
8:15:00 AM	0	42	0	42	0	0	27	0	0	27	0	1	2	0	0	3	0
Grand Total	0	141	0	141	0	0	117	0	0	117	1	1	5	0	0	7	1
% Approach	0.0%	100.0%	0.0%	0.0%	0.0%	0.0%	100.0%	0.0%	0.0%	0.0%	0.0%	0.0%	71.4%	0.0%	0.0%	0.0%	0.0%
% Total	0.0%	53.2%	0.0%	53.2%	0.0%	0.0%	44.2%	0.0%	0.0%	44.2%	0.0%	0.0%	1.9%	0.0%	0.0%	2.6%	0.0%
PHF	0.000	0.839	0.000	0.839	0.000	0.000	0.836	0.000	0.000	0.836	0.000	0.000	0.417	0.000	0.000	0.438	0.000
Lights	0	132	0	132	0	0	109	0	0	109	0	0	5	0	0	5	0
% Lights	0.0%	93.6%	0.0%	93.6%	0.0%	0.0%	93.2%	0.0%	0.0%	93.2%	0.0%	0.0%	100.0%	0.0%	0.0%	71.4%	0.0%
Trucks	0	0	0	0	0	0	1	0	0	1	0	0	0	0	0	0	0
% Trucks	0.0%	0.0%	0.0%	0.0%	0.0%	0.0%	0.9%	0.0%	0.0%	0.9%	0.0%	0.0%	0.0%	0.0%	0.0%	0.0%	0.0%
Buses	0	9	0	9	0	0	7	0	0	7	0	0	0	0	0	0	0
% Buses	0.0%	6.4%	0.0%	6.4%	0.0%	0.0%	6.0%	0.0%	0.0%	6.0%	0.0%	0.0%	0.0%	0.0%	0.0%	0.0%	0.0%
Pedestrians	0	0	0	0	0	0	0	0	0	0	1	1	0	0	0	0	1
% Pedestrians	0.0%	0.0%	0.0%	0.0%	0.0%	0.0%	0.0%	0.0%	0.0%	0.0%	100.0%	100.0%	0.0%	0.0%	0.0%	0.0%	100.0%
Bicycles on Crosswalk	0	0	0	0	0	0	0	0	0	0	0	0	0	0	0	0	0
% Bicycles on Crosswalk	0.0%	0.0%	0.0%	0.0%	0.0%	0.0%	0.0%	0.0%	0.0%	0.0%	0.0%	0.0%	0.0%	0.0%	0.0%	0.0%	0.0%

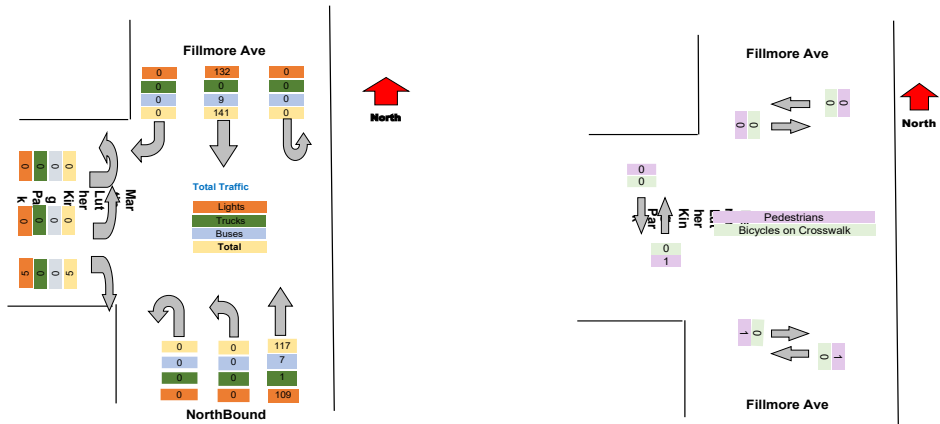

Turning Movement Peak Hour Data (PM)

4:15:00 PM

Leg Direction	Fillmore Ave Southbound						Fillmore Ave NorthBound						Martin Luther King Park Eastbound					
	Right	Thru	U-Turn	App Total	Peds CW	Peds CCW	Thru	Left	U-Turn	App Total	Peds CW	Peds CCW	Right	Left	U-Turn	App Total	Peds CW	
4:15:00 PM	0	63	0	63	0	0	67	0	0	67	0	1	0	1	0	1	0	
4:30:00 PM	0	57	0	57	0	0	67	0	0	67	0	0	1	2	0	3	1	
4:45:00 PM	0	53	0	53	0	0	65	0	0	65	0	0	1	1	0	2	0	
5:00:00 PM	0	63	0	63	0	0	66	0	0	66	0	0	2	1	0	3	0	
Grand Total	0	236	0	236	0	0	265	0	0	265	0	1	4	5	0	9	1	
% Approach	0.0%	100.0%	0.0%	0.0%	0.0%	0.0%	100.0%	0.0%	0.0%	0.0%	0.0%	0.0%	44.4%	55.6%	0.0%	0.0%	0.0%	
% Total	0.0%	46.3%	0.0%	46.3%	0.0%	0.0%	52.0%	0.0%	0.0%	52.0%	0.0%	0.0%	0.8%	1.0%	0.0%	1.8%	0.0%	
PHF	0.000	0.937	0.000	0.937	0.000	0.000	0.989	0.000	0.000	0.989	0.000	0.000	0.500	0.625	0.000	0.750	0.000	
Lights	0	228	0	228	0	0	262	0	0	262	0	0	4	5	0	9	0	
% Lights	0.0%	96.6%	0.0%	96.6%	0.0%	0.0%	98.9%	0.0%	0.0%	98.9%	0.0%	0.0%	100.0%	100.0%	0.0%	100.0%	0.0%	
Trucks	0	2	0	2	0	0	1	0	0	1	0	0	0	0	0	0	0	
% Trucks	0.0%	0.8%	0.0%	0.8%	0.0%	0.0%	0.4%	0.0%	0.0%	0.4%	0.0%	0.0%	0.0%	0.0%	0.0%	0.0%	0.0%	
Buses	0	6	0	6	0	0	2	0	0	2	0	0	0	0	0	0	0	
% Buses	0.0%	2.5%	0.0%	2.5%	0.0%	0.0%	0.8%	0.0%	0.0%	0.8%	0.0%	0.0%	0.0%	0.0%	0.0%	0.0%	0.0%	
Pedestrians	0	0	0	0	0	0	0	0	0	0	0	1	0	0	0	0	1	
% Pedestrians	0.0%	0.0%	0.0%	0.0%	0.0%	0.0%	0.0%	0.0%	0.0%	0.0%	0.0%	100.0%	0.0%	0.0%	0.0%	0.0%	100.0%	
Bicycles on Crosswalk	0	0	0	0	0	0	0	0	0	0	0	0	0	0	0	0	0	
% Bicycles on Crosswalk	0.0%	0.0%	0.0%	0.0%	0.0%	0.0%	0.0%	0.0%	0.0%	0.0%	0.0%	0.0%	0.0%	0.0%	0.0%	0.0%	0.0%	

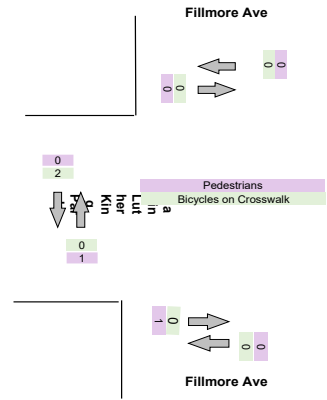
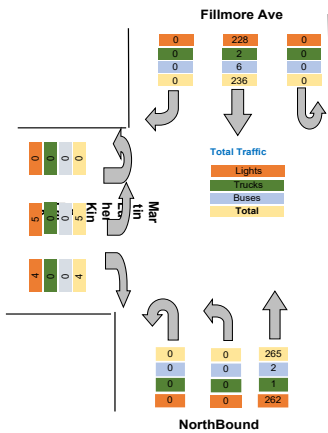

Intersection: Elm St Pine St
 Location: Kennett Square, PA
 Site: 01
 Survey Date: Wednesday, 04-28-2021
 GPS: 42.948550, -72.790034



Peds CCW	Total
1	34
0	54
1	88
4	61
0	58
0	61
0	66
4	246
0	66
0	72
0	138
1	130
1	131
1	127
0	120
3	508
0	132
1	116
0	110
1	107
2	465
10	1445
0.0%	0.0%
0.0%	0.0%
0	1391
0.0%	96.3%
0	5
0.0%	0.3%
0	41
0.0%	2.8%
6	0
60.0%	0.0%
4	0
40.0%	0.0%

Intersection: Elm St Pine St
 Location: Kennett Square, PA
 Site: 01
 Survey Date: Wednesday, 04-28-2021
 GPS: 42.948550, -72.790034



Peds CCW	Total
0	61
0	66
0	66
0	72
0	265
0.0%	
0.0%	
0.000	0.920
0	246
0.0%	92.8%
0	1
0.0%	0.4%
0	16
0.0%	6.0%
0	0
0.0%	0.0%
0	0
0.0%	0.0%

Intersection: Elm St Pine St
 Location: Kennett Square, PA
 Site: 01
 Survey Date: Wednesday, 04-28-2021
 GPS: 42.948550, -72.790034



Peds CCW	Total
1	131
1	127
0	120
0	132
2	510
0.0%	
0.0%	
0.000	0.966
0	499
0.0%	97.8%
0	3
0.0%	0.6%
0	8
0.0%	1.6%
0	0
0.0%	0.0%
2	0
100.0%	0.0%

Project	LaBella
Project Code	LaBella
Site Name	18
Legs and Movements	All Processed Legs & Movements
Bin Size	15 minutes
Survey Date	2021-11-03, Wednesday
Location	18
Latitude and Longitude	42.905776, -78.839064

	Start	End	PHF
Forced Peak AM	2021/11/03 07:30:00	2021/11/03 08:30:00	0.87890625
Forced Peak PM	2021/11/03 16:30:00	2021/11/03 17:30:00	0.866766467
AM Peak	2021/11/03 07:30:00	2021/11/03 08:30:00	0.87890625
PM Peak	2021/11/03 16:15:00	2021/11/03 17:15:00	0.905688623

Turning Movement Data

Leg Direction	Fillmore Ave Southbound						Fillmore Ave NorthBound						Martin Luther King f Eastbound			
	Right	Thru	U-Turn	App Total	Peds CW	Peds CCW	Thru	Left	U-Turn	App Total	Peds CW	Peds CCW	Right	Left	U-Turn	App Total
Start Time																
6:30:00 AM	0	19	0	19	0	0	23	0	0	23	0	0	1	1	0	2
6:45:00 AM	0	18	0	18	0	0	21	0	0	21	0	0	1	0	0	1
Hourly Total	0	37	0	37	0	0	44	0	0	44	0	0	2	1	0	3
7:00:00 AM	0	28	0	28	0	0	25	0	0	25	0	0	0	0	0	0
7:15:00 AM	0	30	0	30	1	0	36	0	0	36	0	0	4	1	0	5
7:30:00 AM	0	39	0	39	0	0	48	0	0	48	0	1	1	0	0	2
7:45:00 AM	0	54	0	54	0	0	60	0	0	60	0	0	4	7	0	11
Hourly Total	0	151	0	151	1	0	169	0	0	169	0	1	9	8	0	18
8:00:00 AM	0	54	0	54	0	0	46	0	0	46	0	0	5	3	0	8
8:15:00 AM	0	58	0	58	0	0	65	0	0	65	1	1	3	0	0	5
Hourly Total	0	112	0	112	0	0	111	0	0	111	1	1	8	3	0	13
4:00:00 PM	0	65	0	65	0	0	75	0	0	75	0	0	1	1	0	2
4:15:00 PM	0	68	0	68	0	0	77	0	0	77	0	0	9	1	0	10
4:30:00 PM	0	78	0	78	0	0	70	0	0	70	0	1	3	2	0	5
4:45:00 PM	0	79	0	79	0	0	83	0	0	83	0	5	2	3	0	5
Hourly Total	0	290	0	290	0	0	305	0	0	305	0	6	15	7	0	22
5:00:00 PM	0	62	0	62	0	0	63	0	1	64	0	0	4	0	0	4
5:15:00 PM	0	76	0	76	0	0	48	0	0	48	4	1	4	1	0	5
5:30:00 PM	0	67	0	67	0	0	68	0	0	68	0	0	1	0	0	1
5:45:00 PM	0	52	0	52	0	0	58	0	0	58	0	0	7	0	0	7
Hourly Total	0	257	0	257	0	0	237	0	1	238	4	1	16	1	0	17
Grand Total	0	847	0	847	1	0	866	0	1	867	5	9	50	20	0	73
% Approach	0.0%	100.0%	0.0%	0.0%	0.0%	0.0%	99.9%	0.0%	0.1%	0.0%	0.0%	0.0%	68.5%	27.4%	0.0%	0.0%
% Total	0.0%	47.4%	0.0%	47.4%	0.0%	0.0%	48.5%	0.0%	0.1%	48.5%	0.0%	0.0%	2.8%	1.1%	0.0%	4.1%
Lights	0	801	0	801	0	0	795	0	1	796	0	0	44	12	0	56
% Lights	0.0%	94.6%	0.0%	94.6%	0.0%	0.0%	91.8%	0.0%	100.0%	91.8%	0.0%	0.0%	88.0%	60.0%	0.0%	76.7%
Trucks	0	2	0	2	0	0	2	0	0	2	0	0	0	0	0	0
% Trucks	0.0%	0.2%	0.0%	0.2%	0.0%	0.0%	0.2%	0.0%	0.0%	0.2%	0.0%	0.0%	0.0%	0.0%	0.0%	0.0%
Buses	0	44	0	44	0	0	69	0	0	69	0	0	6	8	0	14
% Buses	0.0%	5.2%	0.0%	0.0%	0.0%	0.0%	0.0%	0.0%	0.0%	0.0%	0.0%	0.0%	12.0%	40.0%	0.0%	0.0%
Pedestrians	0	0	0	0	1	0	0	0	0	0	5	9	0	0	0	0
% Pedestrians	0.0%	0.0%	0.0%	0.0%	100.0%	0.0%	0.0%	0.0%	0.0%	0.0%	100.0%	100.0%	0.0%	0.0%	0.0%	0.0%
Bicycles on Crosswalk	0	0	0	0	0	0	0	0	0	0	0	0	0	0	0	0
% Bicycles on Crosswalk	0.0%	0.0%	0.0%	0.0%	0.0%	0.0%	0.0%	0.0%	0.0%	0.0%	0.0%	0.0%	0.0%	0.0%	0.0%	0.0%

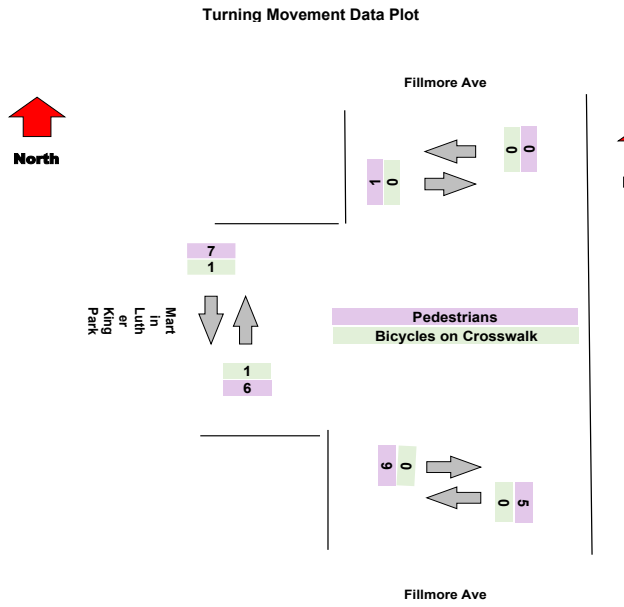
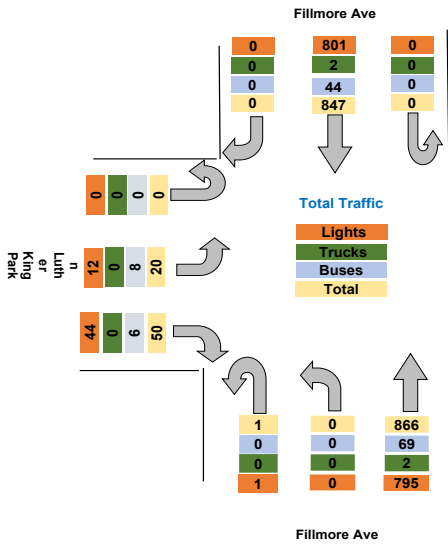

Turning Movement Peak Hour Data (AM)

7:30:00 AM

Leg Direction	Fillmore Ave Southbound						Fillmore Ave NorthBound						Martin Luther King F Eastbound			
	Right	Thru	U-Turn	App Total	Peds CW	Peds CCW	Thru	Left	U-Turn	App Total	Peds CW	Peds CCW	Right	Left	U-Turn	App Total
7:30:00 AM	0	39	0	39	0	0	48	0	0	48	0	1	1	0	0	2
7:45:00 AM	0	54	0	54	0	0	60	0	0	60	0	0	4	7	0	11
8:00:00 AM	0	54	0	54	0	0	46	0	0	46	0	0	5	3	0	8
8:15:00 AM	0	58	0	58	0	0	65	0	0	65	1	1	3	0	0	5
Grand Total	0	205	0	205	0	0	219	0	0	219	1	2	13	10	0	26
% Approach	0.0%	100.0%	0.0%	0.0%	0.0%	0.0%	100.0%	0.0%	0.0%	0.0%	0.0%	0.0%	50.0%	38.5%	0.0%	0.0%
% Total	0.0%	45.6%	0.0%	45.6%	0.0%	0.0%	48.7%	0.0%	0.0%	48.7%	0.0%	0.0%	2.9%	2.2%	0.0%	5.8%
PHF	0.000	0.884	0.000	0.884	0.000	0.000	0.842	0.000	0.000	0.842	0.000	0.000	0.650	0.357	0.000	0.591
Lights	0	192	0	192	0	0	192	0	0	192	0	0	7	2	0	9
% Lights	0.0%	93.7%	0.0%	93.7%	0.0%	0.0%	87.7%	0.0%	0.0%	87.7%	0.0%	0.0%	53.8%	20.0%	0.0%	34.6%
Trucks	0	0	0	0	0	0	0	0	0	0	0	0	0	0	0	0
% Trucks	0.0%	0.0%	0.0%	0.0%	0.0%	0.0%	0.0%	0.0%	0.0%	0.0%	0.0%	0.0%	0.0%	0.0%	0.0%	0.0%
Buses	0	13	0	13	0	0	27	0	0	27	0	0	6	8	0	14
% Buses	0.0%	6.3%	0.0%	6.3%	0.0%	0.0%	12.3%	0.0%	0.0%	12.3%	0.0%	0.0%	46.2%	80.0%	0.0%	53.8%
Pedestrians	0	0	0	0	0	0	0	0	0	0	1	2	0	0	0	0
% Pedestrians	0.0%	0.0%	0.0%	0.0%	0.0%	0.0%	0.0%	0.0%	0.0%	0.0%	100.0%	100.0%	0.0%	0.0%	0.0%	0.0%
Bicycles on Crosswalk	0	0	0	0	0	0	0	0	0	0	0	0	0	0	0	0
% Bicycles on Crosswalk	0.0%	0.0%	0.0%	0.0%	0.0%	0.0%	0.0%	0.0%	0.0%	0.0%	0.0%	0.0%	0.0%	0.0%	0.0%	0.0%

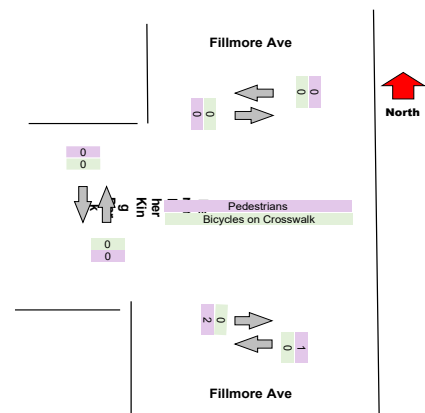
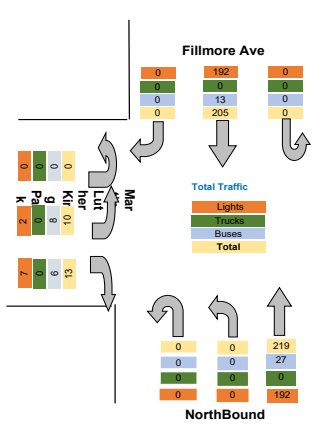

Turning Movement Peak Hour Data (PM)

4:15:00 PM

Leg Direction	Fillmore Ave Southbound						Fillmore Ave NorthBound						Martin Luther King f Eastbound			
	Right	Thru	U-Turn	App Total	Peds CW	Peds CCW	Thru	Left	U-Turn	App Total	Peds CW	Peds CCW	Right	Left	U-Turn	App Total
4:15:00 PM	0	68	0	68	0	0	77	0	0	77	0	0	9	1	0	10
4:30:00 PM	0	78	0	78	0	0	70	0	0	70	0	1	3	2	0	5
4:45:00 PM	0	79	0	79	0	0	83	0	0	83	0	5	2	3	0	5
5:00:00 PM	0	62	0	62	0	0	63	0	1	64	0	0	4	0	0	4
Grand Total	0	287	0	287	0	0	293	0	1	294	0	6	18	6	0	24
% Approach	0.0%	100.0%	0.0%	0.0%	0.0%	0.0%	99.7%	0.0%	0.3%	0.0%	0.0%	0.0%	75.0%	25.0%	0.0%	0.0%
% Total	0.0%	47.4%	0.0%	47.4%	0.0%	0.0%	48.4%	0.0%	0.2%	48.6%	0.0%	0.0%	3.0%	1.0%	0.0%	4.0%
PHF	0.000	0.908	0.000	0.908	0.000	0.000	0.883	0.000	0.250	0.886	0.000	0.000	0.500	0.500	0.000	0.600
Lights	0	272	0	272	0	0	278	0	1	279	0	0	18	6	0	24
% Lights	0.0%	94.8%	0.0%	94.8%	0.0%	0.0%	94.9%	0.0%	100.0%	94.9%	0.0%	0.0%	100.0%	100.0%	0.0%	100.0%
Trucks	0	1	0	1	0	0	1	0	0	1	0	0	0	0	0	0
% Trucks	0.0%	0.3%	0.0%	0.3%	0.0%	0.0%	0.3%	0.0%	0.0%	0.3%	0.0%	0.0%	0.0%	0.0%	0.0%	0.0%
Buses	0	14	0	14	0	0	14	0	0	14	0	0	0	0	0	0
% Buses	0.0%	4.9%	0.0%	4.9%	0.0%	0.0%	4.8%	0.0%	0.0%	4.8%	0.0%	0.0%	0.0%	0.0%	0.0%	0.0%
Pedestrians	0	0	0	0	0	0	0	0	0	0	6	0	0	0	0	0
% Pedestrians	0.0%	0.0%	0.0%	0.0%	0.0%	0.0%	0.0%	0.0%	0.0%	0.0%	100.0%	0.0%	0.0%	0.0%	0.0%	0.0%
Bicycles on Crosswalk	0	0	0	0	0	0	0	0	0	0	0	0	0	0	0	0
% Bicycles on Crosswalk	0.0%	0.0%	0.0%	0.0%	0.0%	0.0%	0.0%	0.0%	0.0%	0.0%	0.0%	0.0%	0.0%	0.0%	0.0%	0.0%

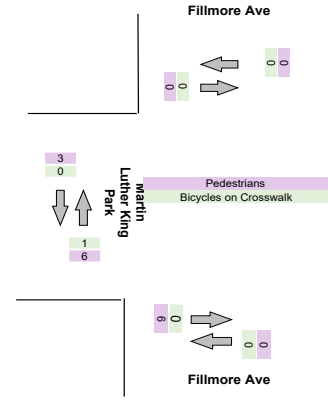
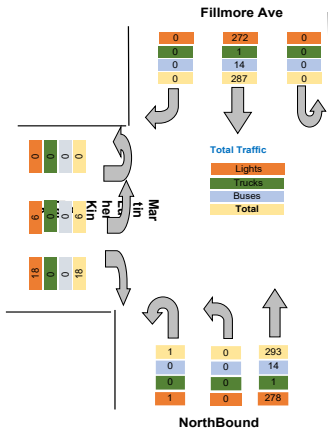

Intersection: Elm St Pine St
 Location: Kennett Square, PA
 Site: 01
 Survey Date: Wednesday, 04-28-2021
 GPS: 42.948550, -72.790034

Park		
Peds CW	Peds CCW	Total
0	0	44
0	0	40
0	0	84
0	0	53
0	2	71
0	0	89
0	0	125
0	2	338
0	0	108
0	0	128
0	0	236
0	1	142
0	1	155
1	0	153
4	2	167
5	4	617
2	0	130
0	2	129
0	0	136
0	0	117
2	2	512
7	8	1787
0.0%	0.0%	0.0%
0.0%	0.0%	0.0%
0	0	1653
0.0%	0.0%	92.5%
0	0	4
0.0%	0.0%	0.2%
0	0	127
0.0%	0.0%	7.1%
6	7	0
65.7%	67.5%	0.0%
1	1	0
14.3%	12.5%	0.0%

Intersection: Elm St Pine St
Location: Kennett Square, PA
Site: 01
Survey Date: Wednesday, 04-28-2021
GPS: 42.948550, -72.790034



North

Intersection: Elm St Pine St
 Location: Kennett Square, PA
 Site: 01
 Survey Date: Wednesday, 04-28-2021
 GPS: 42.948550, -72.790034

Park		
Peds CW	Peds CCW	Total
0	0	89
0	0	125
0	0	108
0	0	128
0	0	450
0.0%	0.0%	
0.0%	0.0%	
0.000	0.000	0.879
0	0	393
0.0%	0.0%	87.3%
0	0	0
0.0%	0.0%	0.0%
0	0	54
0.0%	0.0%	12.0%
0	0	0
0.0%	0.0%	0.0%
0	0	0
0.0%	0.0%	0.0%

Intersection: Elm St Pine St
 Location: Kennett Square, PA
 Site: 01
 Survey Date: Wednesday, 04-28-2021
 GPS: 42.948550, -72.790034



Park		
Peds CW	Peds CCW	Total
0	1	155
1	0	153
4	2	167
2	0	130
7	3	605
0.0%	0.0%	
0.0%	0.0%	
0.000	0.000	0.906
0	0	575
0.0%	0.0%	95.0%
0	0	2
0.0%	0.0%	0.3%
0	0	28
0.0%	0.0%	4.6%
6	3	0
85.7%	100.0%	0.0%
1	0	0
14.3%	0.0%	0.0%

Project	LaBella
Project Code	LaBella
Site Name	18
Legs and Movements	All Processed Legs & Movements
Bin Size	15 minutes
Survey Date	2021-11-04, Thursday
Location	18
Latitude and Longitude	42.905776, -78.839064

	Start	End	PHF
Forced Peak AM	2021/11/04 07:30:00	2021/11/04 08:30:00	0.838
Forced Peak PM	2021/11/04 16:30:00	2021/11/04 17:30:00	0.944
AM Peak	2021/11/04 07:30:00	2021/11/04 08:30:00	0.838
PM Peak	2021/11/04 16:15:00	2021/11/04 17:15:00	0.952

Turning Movement Data

Leg Direction	Fillmore Ave Southbound					Fillmore Ave Northbound					Martin Luther King Park Eastbound				
	Right	Thru	U-Turn	App Total	Peds CW Peds CCW	Thru	Left	U-Turn	App Total	Peds CW Peds CCW	Right	Left	U-Turn	App Total	Peds CW
Start Time															
6:30:00 AM	0	21	0	21	0 0	16	0	0	16	0 0	1	0	0	1	0
6:45:00 AM	0	23	0	23	0 0	19	0	0	19	0 1	1	0	0	2	0
Hourly Total	0	44	0	44	0 0	35	0	0	35	0 1	2	0	0	3	0
7:00:00 AM	0	25	0	25	0 0	25	0	0	25	0 0	0	0	0	0	1
7:15:00 AM	0	23	0	23	0 0	30	0	0	30	1 0	1	0	0	2	0
7:30:00 AM	0	48	0	48	0 0	40	0	0	40	0 0	1	1	0	2	0
7:45:00 AM	0	53	0	53	0 0	52	0	0	52	0 0	3	5	0	8	0
Hourly Total	0	149	0	149	0 0	147	0	0	147	1 0	5	6	0	12	1
8:00:00 AM	0	70	0	70	0 0	51	0	0	51	0 2	9	4	0	15	0
8:15:00 AM	0	61	0	61	0 0	46	0	0	46	4 0	6	0	0	10	1
Hourly Total	0	131	0	131	0 0	97	0	0	97	4 2	15	4	0	25	1
4:00:00 PM	0	69	0	69	0 0	68	0	0	68	0 0	5	3	0	8	1
4:15:00 PM	0	75	0	75	0 0	75	0	0	75	0 0	3	1	0	4	1
4:30:00 PM	0	62	0	62	0 0	81	0	0	81	0 0	3	0	0	3	0
4:45:00 PM	0	85	0	85	0 0	69	0	0	69	0 1	4	3	0	7	0
Hourly Total	0	291	0	291	0 0	293	0	0	293	0 1	15	7	0	22	2
5:00:00 PM	0	69	0	69	0 0	81	0	0	81	1 0	2	0	0	2	2
5:15:00 PM	0	73	0	73	0 0	75	0	0	75	0 1	1	0	0	1	0
5:30:00 PM	0	66	0	66	0 0	51	0	0	51	0 0	3	0	0	3	0
5:45:00 PM	0	67	0	67	0 0	55	0	0	55	0 0	1	0	0	1	0
Hourly Total	0	275	0	275	0 0	262	0	0	262	1 1	7	0	0	7	2
Grand Total	0	890	0	890	0 0	834	0	0	834	6 5	44	17	0	69	6
% Approach	0.0%	100.0%	0.0%	0.0%	0.0%	100.0%	0.0%	0.0%	0.0%	0.0%	63.8%	24.6%	0.0%	0.0%	0.0%
% Total	0.0%	49.6%	0.0%	49.6%	0.0%	46.5%	0.0%	0.0%	46.5%	0.0%	2.5%	0.9%	0.0%	3.8%	0.0%
Lights	0	842	0	842	0 0	767	0	0	767	0 0	37	10	0	47	0
% Lights	0.0%	94.6%	0.0%	94.6%	0.0%	92.0%	0.0%	0.0%	92.0%	0.0%	84.1%	58.8%	0.0%	68.1%	0.0%
Trucks	0	2	0	2	0 0	1	0	0	1	0 0	0	0	0	0	0
% Trucks	0.0%	0.2%	0.0%	0.2%	0.0%	0.1%	0.0%	0.0%	0.1%	0.0%	0.0%	0.0%	0.0%	0.0%	0.0%
Buses	0	46	0	46	0 0	66	0	0	66	0 0	7	7	0	14	0
% Buses	0.0%	5.2%	0.0%	0.0%	0.0%	0.0%	0.0%	0.0%	0.0%	0.0%	15.9%	41.2%	0.0%	0.0%	0.0%
Pedestrians	0	0	0	0	0 0	0	0	0	0	6 5	0	0	0	0	6
% Pedestrians	0.0%	0.0%	0.0%	0.0%	0.0%	0.0%	0.0%	0.0%	0.0%	100.0%	0.0%	0.0%	0.0%	0.0%	100.0%
Bicycles on Crosswalk	0	0	0	0	0 0	0	0	0	0	0 0	0	0	0	0	0
% Bicycles on Crosswalk	0.0%	0.0%	0.0%	0.0%	0.0%	0.0%	0.0%	0.0%	0.0%	0.0%	0.0%	0.0%	0.0%	0.0%	0.0%

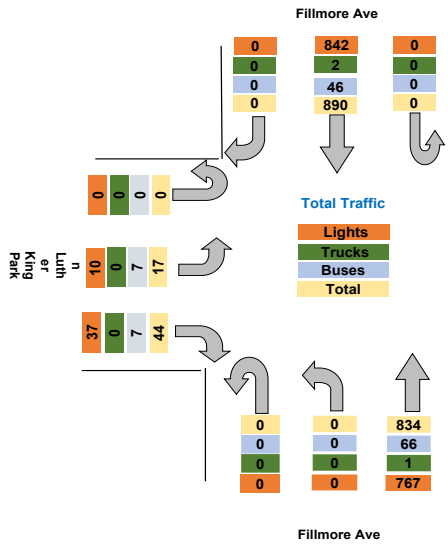

Turning Movement Data Plot

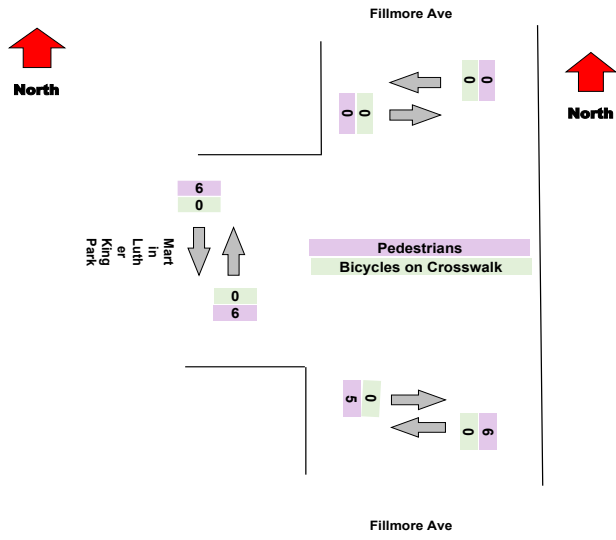

Turning Movement Peak Hour Data (AM)

7:30:00 AM

Leg Direction	Fillmore Ave Southbound						Fillmore Ave NorthBound						Martin Luther King Park Eastbound				
	Right	Thru	U-Turn	App Total	Peds CW	Peds CCW	Thru	Left	U-Turn	App Total	Peds CW	Peds CCW	Right	Left	U-Turn	App Total	Peds CW
7:30:00 AM	0	48	0	48	0	0	40	0	0	40	0	0	1	1	0	2	0
7:45:00 AM	0	53	0	53	0	0	52	0	0	52	0	0	3	5	0	8	0
8:00:00 AM	0	70	0	70	0	0	51	0	0	51	0	2	9	4	0	15	0
8:15:00 AM	0	61	0	61	0	0	46	0	0	46	4	0	6	0	0	10	1
Grand Total	0	232	0	232	0	0	189	0	0	189	4	2	19	10	0	35	1
% Approach	0.0%	100.0%	0.0%	0.0%	0.0%	0.0%	100.0%	0.0%	0.0%	0.0%	0.0%	0.0%	54.3%	28.6%	0.0%	0.0%	0.0%
% Total	0.0%	50.9%	0.0%	50.9%	0.0%	0.0%	41.4%	0.0%	0.0%	41.4%	0.0%	0.0%	4.2%	2.2%	0.0%	7.7%	0.0%
PHF	0.000	0.829	0.000	0.829	0.000	0.000	0.909	0.000	0.000	0.909	0.000	0.000	0.528	0.500	0.000	0.583	0.000
Lights	0	218	0	218	0	0	165	0	0	165	0	0	12	3	0	15	0
% Lights	0.0%	94.0%	0.0%	94.0%	0.0%	0.0%	87.3%	0.0%	0.0%	87.3%	0.0%	0.0%	63.2%	30.0%	0.0%	42.9%	0.0%
Trucks	0	0	0	0	0	0	0	0	0	0	0	0	0	0	0	0	0
% Trucks	0.0%	0.0%	0.0%	0.0%	0.0%	0.0%	0.0%	0.0%	0.0%	0.0%	0.0%	0.0%	0.0%	0.0%	0.0%	0.0%	0.0%
Buses	0	14	0	14	0	0	24	0	0	24	0	0	7	7	0	14	0
% Buses	0.0%	6.0%	0.0%	6.0%	0.0%	0.0%	12.7%	0.0%	0.0%	12.7%	0.0%	0.0%	36.8%	70.0%	0.0%	40.0%	0.0%
Pedestrians	0	0	0	0	0	0	0	0	0	0	4	2	0	0	0	0	1
% Pedestrians	0.0%	0.0%	0.0%	0.0%	0.0%	0.0%	0.0%	0.0%	0.0%	100.0%	100.0%	0.0%	0.0%	0.0%	0.0%	0.0%	100.0%
Bicycles on Crosswalk	0	0	0	0	0	0	0	0	0	0	0	0	0	0	0	0	0
% Bicycles on Crosswalk	0.0%	0.0%	0.0%	0.0%	0.0%	0.0%	0.0%	0.0%	0.0%	0.0%	0.0%	0.0%	0.0%	0.0%	0.0%	0.0%	0.0%

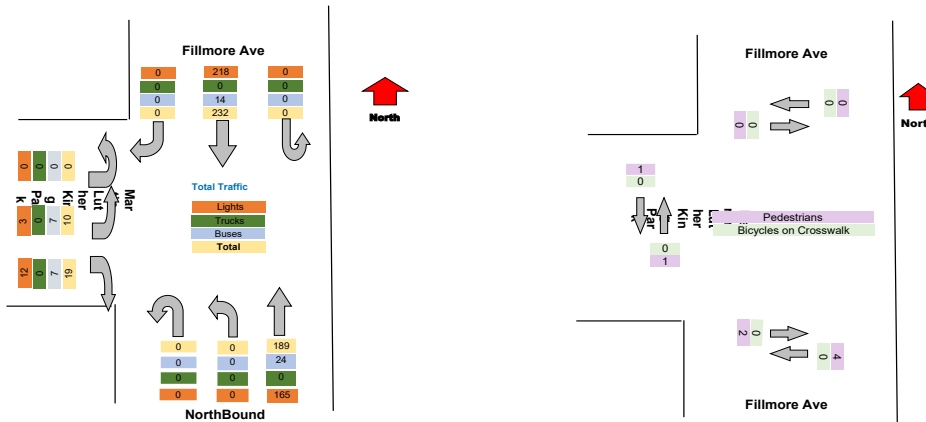

Turning Movement Peak Hour Data (PM)

4:15:00 PM

Leg Direction	Fillmore Ave Southbound						Fillmore Ave NorthBound						Martin Luther King Park Eastbound					
	Right	Thru	U-Turn	App Total	Peds CW	Peds CCW	Thru	Left	U-Turn	App Total	Peds CW	Peds CCW	Right	Left	U-Turn	App Total	Peds CW	
4:15:00 PM	0	75	0	75	0	0	75	0	0	75	0	0	3	1	0	4	1	
4:30:00 PM	0	62	0	62	0	0	81	0	0	81	0	0	3	0	0	3	0	
4:45:00 PM	0	85	0	85	0	0	69	0	0	69	0	1	4	3	0	7	0	
5:00:00 PM	0	69	0	69	0	0	81	0	0	81	1	0	2	0	0	2	2	
Grand Total	0	291	0	291	0	0	306	0	0	306	1	1	12	4	0	16	3	
% Approach	0.0%	100.0%	0.0%	0.0%	0.0%	0.0%	100.0%	0.0%	0.0%	0.0%	0.0%	0.0%	75.0%	25.0%	0.0%	0.0%	0.0%	
% Total	0.0%	47.5%	0.0%	47.5%	0.0%	0.0%	49.9%	0.0%	0.0%	49.9%	0.0%	0.0%	2.0%	0.7%	0.0%	2.6%	0.0%	
PHF	0.000	0.856	0.000	0.856	0.000	0.000	0.944	0.000	0.000	0.944	0.000	0.000	0.750	0.333	0.000	0.571	0.000	
Lights	0	275	0	275	0	0	291	0	0	291	0	0	12	4	0	16	0	
% Lights	0.0%	94.5%	0.0%	94.5%	0.0%	0.0%	95.1%	0.0%	0.0%	95.1%	0.0%	0.0%	100.0%	100.0%	0.0%	100.0%	0.0%	
Trucks	0	1	0	1	0	0	0	0	0	0	0	0	0	0	0	0	0	
% Trucks	0.0%	0.3%	0.0%	0.3%	0.0%	0.0%	0.0%	0.0%	0.0%	0.0%	0.0%	0.0%	0.0%	0.0%	0.0%	0.0%	0.0%	
Buses	0	15	0	15	0	0	15	0	0	15	0	0	0	0	0	0	0	
% Buses	0.0%	5.2%	0.0%	5.2%	0.0%	0.0%	4.9%	0.0%	0.0%	4.9%	0.0%	0.0%	0.0%	0.0%	0.0%	0.0%	0.0%	
Pedestrians	0	0	0	0	0	0	0	0	0	0	1	1	0	0	0	0	3	
% Pedestrians	0.0%	0.0%	0.0%	0.0%	0.0%	0.0%	0.0%	0.0%	0.0%	0.0%	100.0%	100.0%	0.0%	0.0%	0.0%	0.0%	100.0%	
Bicycles on Crosswalk	0	0	0	0	0	0	0	0	0	0	0	0	0	0	0	0	0	
% Bicycles on Crosswalk	0.0%	0.0%	0.0%	0.0%	0.0%	0.0%	0.0%	0.0%	0.0%	0.0%	0.0%	0.0%	0.0%	0.0%	0.0%	0.0%	0.0%	

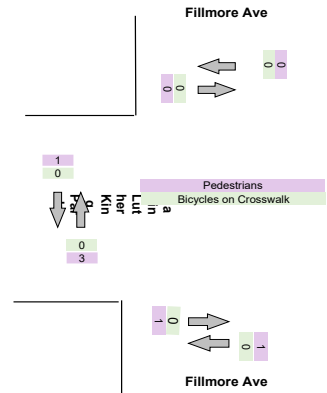
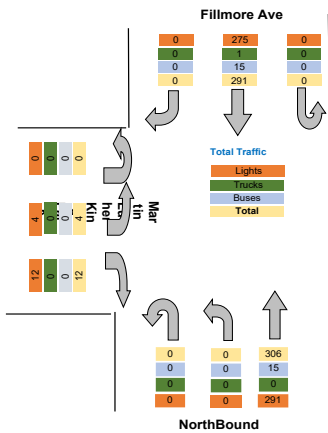

Intersection: Elm St Pine St
 Location: Kennett Square, PA
 Site: 01
 Survey Date: Wednesday, 04-28-2021
 GPS: 42.948550, -72.790034

Peds CCW	Total
0	38
1	44
1	82
0	50
1	55
1	90
0	113
2	308
0	136
0	117
0	253
0	145
0	154
1	146
0	161
1	606
0	152
0	149
2	120
0	123
2	544
6	1793
0.0%	0.0%
0.0%	0.0%
0	1656
0.0%	92.4%
0	3
0.0%	0.2%
0	126
0.0%	7.0%
6	0
100.0%	0.0%
0	0
0.0%	0.0%

Intersection: Elm St Pine St
 Location: Kennett Square, PA
 Site: 01
 Survey Date: Wednesday, 04-28-2021
 GPS: 42.948550, -72.790034



Peds CCW	Total
1	90
0	113
0	136
0	117
1	456
0.0%	
0.0%	
0.000	0.838
0	398
0.0%	87.3%
0	0
0.0%	0.0%
0	52
0.0%	11.4%
1	0
100.0%	0.0%
0	0
0.0%	0.0%

Intersection: Elm St Pine St
 Location: Kennett Square, PA
 Site: 01
 Survey Date: Wednesday, 04-28-2021
 GPS: 42.948550, -72.790034



Peds CCW	Total
0	154
1	146
0	161
0	152
1	613
0.0%	
0.0%	
0.000	0.952
0	582
0.0%	94.9%
0	1
0.0%	0.2%
0	30
0.0%	4.9%
1	0
100.0%	0.0%
0	0
0.0%	0.0%

Project : VBH Malta NY
Site : Site 4
Location : 42.948550, -73.790036

TSTData.com

Survey Date : 2021-04-28, Wednesday

Project	LaBella
Project Code	LaBella
Site Name	19
Legs and Movements	All Processed Legs & Move
Bin Size	15 minutes
Survey Date	2021-11-02, Tuesday
Location	19
Latitude and Longitude	42.907282, -78.839084

	Start	End	PHF
Forced Peak AM	2021/11/02 07:30:00	2021/11/02 08:30:00	0.88
Forced Peak PM	2021/11/02 16:30:00	2021/11/02 17:30:00	0.91
AM Peak	2021/11/02 07:30:00	2021/11/02 08:30:00	0.88
PM Peak	2021/11/02 16:15:00	2021/11/02 17:15:00	0.92

Turning Movement Data

Leg Direction	Fillmore Ave										Northampton St										Total								
	Southbound					Westbound					Northbound					Eastbound													
	Right	Thru	Left	U-Turn	App Total	Peds CV	Peds CCV	Right	Thru	Left	U-Turn	App Total	Peds CV	Peds CCV	Right	Thru	Left	U-Turn	App Total	Peds CV		Peds CCV							
6:30:00 AM	1	15	3	0	19	0	0	1	0	0	0	1	0	0	1	16	1	0	18	0	1	1	3	2	0	6	0	1	44
6:45:00 AM	0	26	1	0	27	0	0	0	2	1	0	3	0	0	3	18	0	0	21	0	1	1	2	0	0	3	1	1	54
Hourly Total	1	41	4	0	46	0	0	1	2	1	0	4	0	0	4	34	1	0	39	0	2	2	5	2	0	9	1	2	98
7:00:00 AM	4	18	0	0	22	0	0	0	9	1	0	6	0	0	1	22	2	0	25	0	0	2	2	0	0	4	0	0	57
7:15:00 AM	2	25	0	0	27	0	0	1	2	1	0	4	0	1	0	29	3	0	33	1	1	0	5	1	0	6	0	0	70
7:30:00 AM	2	28	0	0	30	0	0	0	6	0	0	6	0	0	0	27	1	0	28	0	0	1	8	1	0	10	1	0	74
7:45:00 AM	5	37	1	0	43	0	0	0	4	3	0	7	0	0	2	36	1	0	39	0	0	2	7	0	0	9	0	0	98
Hourly Total	13	108	1	0	122	0	0	1	17	5	0	23	0	1	3	114	7	0	125	1	1	5	22	2	0	29	1	0	299
8:00:00 AM	5	36	0	0	41	0	0	1	6	0	0	7	0	0	0	21	3	0	24	0	0	1	4	3	0	8	0	0	80
8:15:00 AM	3	42	1	0	46	0	0	3	9	0	0	12	0	0	0	23	2	0	25	0	0	0	9	2	0	11	0	1	94
Hourly Total	8	78	1	0	87	0	0	4	15	0	0	19	0	0	0	44	5	0	49	0	0	1	13	5	0	19	0	1	174
4:00:00 PM	8	71	3	0	82	0	1	3	8	0	0	11	1	2	0	50	2	0	52	0	1	7	12	6	0	25	0	1	170
4:15:00 PM	4	62	1	0	67	0	0	0	8	3	0	11	0	0	1	65	7	0	73	0	0	2	15	3	0	20	1	1	171
4:30:00 PM	8	49	1	0	58	0	0	1	7	2	0	10	0	0	2	64	4	0	70	0	0	4	9	5	0	18	1	1	156
4:45:00 PM	9	60	2	0	71	0	0	5	6	2	0	13	0	0	4	63	1	0	68	0	0	2	14	7	0	23	3	1	175
Hourly Total	29	242	7	0	278	0	1	9	29	7	0	45	1	2	7	242	14	0	263	0	1	15	50	21	0	86	4	4	672
5:00:00 PM	15	64	5	0	74	0	0	4	10	3	0	17	0	0	2	67	2	0	71	0	1	9	11	4	0	24	0	1	186
5:15:00 PM	5	49	2	0	56	0	0	4	10	1	0	15	1	0	5	62	7	0	74	0	1	3	11	2	0	16	1	1	161
5:30:00 PM	6	65	1	0	72	0	0	3	6	0	0	9	0	1	0	57	0	0	57	0	0	2	14	6	0	22	0	0	160
5:45:00 PM	6	47	3	0	56	0	0	2	8	1	0	11	2	0	0	48	2	0	50	0	0	2	12	3	0	17	0	1	134
Hourly Total	32	215	11	0	258	0	0	13	34	5	0	52	3	1	7	234	11	0	252	0	2	16	48	15	0	79	1	5	641
Grand Total	83	684	24	0	791	0	1	28	97	18	0	143	4	4	21	668	38	0	728	1	6	39	138	45	0	222	7	12	1884
% Approach	10.5%	86.5%	3.0%	0.0%	0.0%	0.0%	0.0%	19.6%	67.8%	12.6%	0.0%	0.0%	0.0%	0.0%	2.9%	91.8%	5.2%	0.0%	0.0%	0.0%	0.0%	17.6%	62.2%	20.3%	0.0%	0.0%	0.0%	0.0%	0.0%
% Total	4.4%	36.3%	1.3%	0.0%	42.0%	0.0%	0.0%	1.5%	5.1%	1.0%	0.0%	7.6%	0.0%	0.0%	1.1%	35.5%	2.0%	0.0%	38.6%	0.0%	0.0%	2.1%	7.3%	2.4%	0.0%	11.8%	0.0%	0.0%	0.0%
Lights	82	660	24	0	766	0	0	28	95	18	0	141	0	0	21	645	38	0	704	0	0	39	136	44	0	219	0	0	1830
% Lights	98.8%	96.5%	100.0%	0.0%	96.8%	0.0%	0.0%	100.0%	97.9%	100.0%	0.0%	98.6%	0.0%	0.0%	100.0%	96.6%	100.0%	0.0%	96.7%	0.0%	0.0%	100.0%	98.6%	97.8%	0.0%	98.6%	0.0%	0.0%	97.1%
Trucks	0	2	0	0	2	0	0	0	0	0	0	0	0	0	0	2	0	0	2	0	0	0	0	0	0	0	0	0	4
% Trucks	0.0%	0.3%	0.0%	0.0%	0.3%	0.0%	0.0%	0.0%	0.0%	0.0%	0.0%	0.0%	0.0%	0.0%	0.0%	0.3%	0.0%	0.0%	0.3%	0.0%	0.0%	0.0%	0.0%	0.0%	0.0%	0.0%	0.0%	0.0%	0.2%
Buses	1	22	0	0	23	0	0	0	2	0	0	2	0	0	0	20	0	0	20	0	0	0	2	1	0	3	0	0	48
% Buses	1.2%	3.2%	0.0%	0.0%	0.0%	0.0%	0.0%	0.0%	2.1%	0.0%	0.0%	0.0%	0.0%	0.0%	0.0%	3.0%	0.0%	0.0%	0.0%	0.0%	0.0%	0.0%	1.4%	2.2%	0.0%	0.0%	0.0%	0.0%	2.5%
Pedestrians	0	0	0	0	0	0	0	0	0	0	0	0	3	3	0	0	0	0	0	1	6	0	0	0	0	0	6	9	0
% Pedestrians	0.0%	0.0%	0.0%	0.0%	0.0%	0.0%	100.0%	0.0%	0.0%	0.0%	0.0%	0.0%	75.0%	75.0%	0.0%	0.0%	0.0%	0.0%	0.0%	100.0%	100.0%	0.0%	0.0%	0.0%	0.0%	0.0%	85.7%	75.0%	0.0%
Bicycles on Crosswalk	0	0	0	0	0	0	0	0	0	0	0	0	1	1	0	0	0	0	0	0	0	0	0	0	0	0	1	3	0
% Bicycles on Crosswalk	0.0%	0.0%	0.0%	0.0%	0.0%	0.0%	0.0%	0.0%	0.0%	0.0%	0.0%	0.0%	25.0%	25.0%	0.0%	0.0%	0.0%	0.0%	0.0%	0.0%	0.0%	0.0%	0.0%	0.0%	0.0%	0.0%	14.3%	25.0%	0.0%

Project : VBH Malta NY
 Site : Site 4
 Location : 42.948550, -73.790036
 Survey Date : 2021-04-28, Wednesday

Turning Movement Data Plot

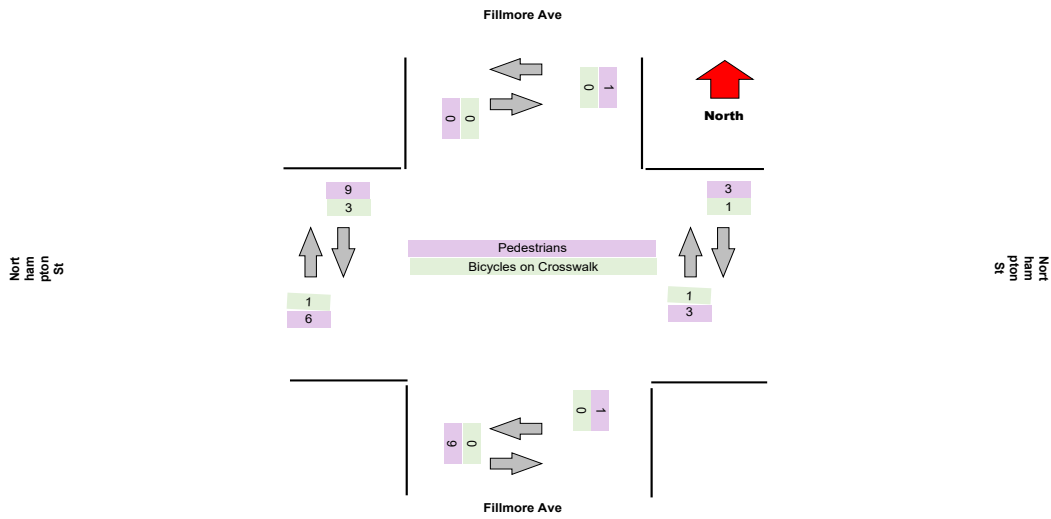
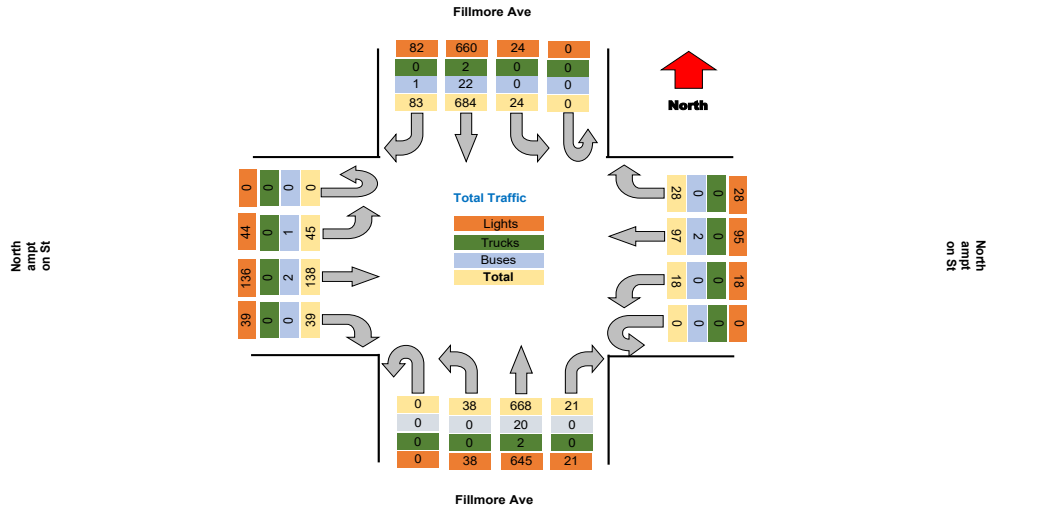

Project : VBH Malta NY
Site : Site 4
Location : 42.948550, -73.790036
Survey Date : 2021-04-28, Wednesday

TSTData.com

Turning Movement Peak Hour Data (AM)

7:30:00 AM

Leg Direction	Fillmore Ave				Northampton St				Fillmore Ave				Northampton St				Total					
	Southbound		Northbound		Westbound		Eastbound		Northbound		Southbound		Westbound		Eastbound							
Start Time	Right	Thru	Left	U-Turn	App Total	Peds CW	Peds CCW	Right	Thru	Left	U-Turn	App Total	Peds CW	Peds CCW	Right	Thru	Left	U-Turn	App Total	Peds CW	Peds CCW	
7:30:00 AM	2	28	0	0	30	0	0	0	6	0	0	6	0	0	0	27	1	0	28	0	0	74
7:45:00 AM	5	37	1	0	43	0	0	0	4	3	0	7	0	0	2	36	1	0	39	0	0	98
8:00:00 AM	5	36	0	0	41	0	0	1	6	0	0	7	0	0	0	21	3	0	24	0	0	80
8:15:00 AM	3	42	1	0	46	0	0	3	9	0	0	12	0	0	0	23	2	0	25	0	0	94
Grand Total	15	143	2	0	160	0	0	4	25	3	0	32	0	0	2	107	7	0	116	0	0	346
% Approach	9.4%	89.4%	1.3%	0.0%	0.0%	0.0%	0.0%	12.5%	78.1%	9.4%	0.0%	0.0%	0.0%	0.0%	1.7%	92.2%	6.0%	0.0%	0.0%	0.0%	0.0%	0.0%
% Total	4.3%	41.3%	0.6%	0.0%	46.2%	0.0%	0.0%	1.2%	7.2%	0.9%	0.0%	8.2%	0.0%	0.0%	0.6%	30.9%	2.0%	0.0%	33.5%	0.0%	0.0%	0.0%
PHF	0.750	0.851	0.500	0.000	0.870	0.000	0.000	0.333	0.694	0.250	0.000	0.667	0.000	0.000	0.250	0.743	0.583	0.000	0.744	0.000	0.000	0.883
Lights	15	136	2	0	153	0	0	4	25	3	0	32	0	0	2	98	7	0	107	0	0	330
% Lights	100.0%	95.1%	100.0%	0.0%	95.6%	0.0%	0.0%	100.0%	100.0%	100.0%	0.0%	100.0%	0.0%	0.0%	100.0%	91.6%	100.0%	0.0%	92.2%	0.0%	0.0%	95.4%
Trucks	0	0	0	0	0	0	0	0	0	0	0	0	0	0	0	0	0	0	0	0	0	0
% Trucks	0.0%	0.0%	0.0%	0.0%	0.0%	0.0%	0.0%	0.0%	0.0%	0.0%	0.0%	0.0%	0.0%	0.0%	0.0%	0.0%	0.0%	0.0%	0.0%	0.0%	0.0%	0.0%
Buses	0	7	0	0	7	0	0	0	0	0	0	0	0	0	0	9	0	0	9	0	0	16
% Buses	0.0%	4.9%	0.0%	0.0%	0.0%	0.0%	0.0%	0.0%	0.0%	0.0%	0.0%	0.0%	0.0%	0.0%	0.0%	8.4%	0.0%	0.0%	0.0%	0.0%	0.0%	4.6%
Pedestrians	0	0	0	0	0	0	0	0	0	0	0	0	0	0	0	0	0	0	0	0	1	1
% Pedestrians	0.0%	0.0%	0.0%	0.0%	0.0%	0.0%	0.0%	0.0%	0.0%	0.0%	0.0%	0.0%	0.0%	0.0%	0.0%	0.0%	0.0%	0.0%	0.0%	0.0%	100.0%	100.0%
Bicycles on Crosswalk	0	0	0	0	0	0	0	0	0	0	0	0	0	0	0	0	0	0	0	0	0	0
% Bicycles on Crosswalk	0.0%	0.0%	0.0%	0.0%	0.0%	0.0%	0.0%	0.0%	0.0%	0.0%	0.0%	0.0%	0.0%	0.0%	0.0%	0.0%	0.0%	0.0%	0.0%	0.0%	0.0%	0.0%

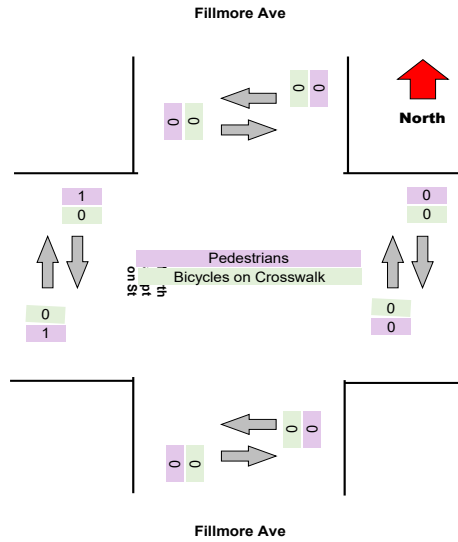
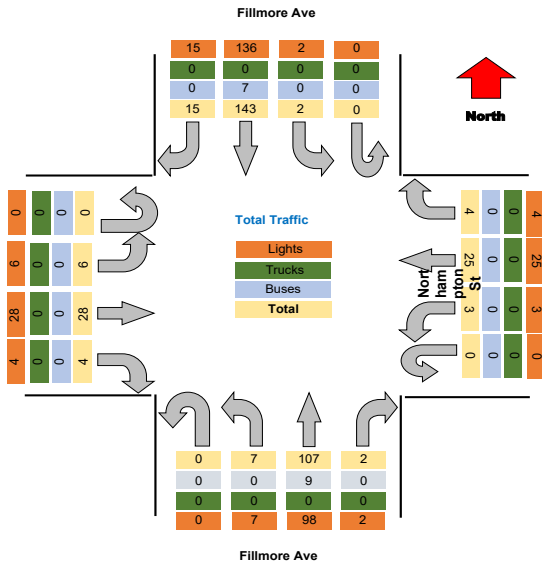

Turning Movement Peak Hour Data (PM)

4:15:00 PM

Leg Direction	Fillmore Ave												Northampton St												Total				
	Southbound						Westbound						Northbound						Eastbound										
	Right	Thru	Left	U-Turn	App Total	Peds CW	Peds CCW	Right	Thru	Left	U-Turn	App Total	Peds CW	Peds CCW	Right	Thru	Left	U-Turn	App Total	Peds CW	Peds CCW	Right	Thru	Left		U-Turn	App Total	Peds CW	Peds CCW
4:15:00 PM	4	62	1	0	67	0	0	0	8	3	0	11	0	0	1	65	7	0	73	0	0	2	15	3	0	20	1	1	171
4:30:00 PM	8	49	1	0	58	0	0	1	7	2	0	10	0	0	2	64	4	0	70	0	0	4	9	5	0	18	1	1	166
4:45:00 PM	9	60	2	0	71	0	0	5	6	2	0	13	0	0	4	63	1	0	68	0	0	2	14	7	0	23	2	1	175
5:00:00 PM	15	54	5	0	74	0	0	4	10	3	0	17	0	0	2	57	2	0	61	0	0	9	11	4	0	24	0	3	168
Grand Total	36	225	9	0	270	0	0	10	31	10	0	51	0	0	9	259	14	0	282	0	0	17	49	19	0	85	4	6	688
% Approach	13.3%	83.3%	3.3%	0.0%	0.0%	0.0%	0.0%	19.6%	60.8%	19.6%	0.0%	0.0%	0.0%	0.0%	3.2%	91.6%	5.0%	0.0%	0.0%	0.0%	0.0%	20.0%	57.6%	22.4%	0.0%	0.0%	0.0%	0.0%	
% Total	5.2%	32.7%	1.3%	0.0%	38.2%	0.0%	0.0%	1.5%	4.5%	1.5%	0.0%	7.4%	0.0%	0.0%	1.3%	37.6%	2.0%	0.0%	41.0%	0.0%	0.0%	2.5%	7.1%	2.8%	0.0%	12.4%	0.0%	0.0%	
PHF	0.600	0.907	0.450	0.000	0.912	0.000	0.000	0.500	0.775	0.833	0.000	0.750	0.000	0.000	0.563	0.966	0.500	0.000	0.866	0.000	0.000	0.472	0.817	0.679	0.000	0.885	0.000	0.000	0.925
Lights	35	217	9	0	261	0	0	10	31	10	0	51	0	0	9	255	14	0	278	0	0	17	48	19	0	84	0	0	674
% Lights	97.2%	96.4%	100.0%	0.0%	96.7%	0.0%	0.0%	100.0%	100.0%	100.0%	0.0%	100.0%	0.0%	0.0%	100.0%	98.5%	100.0%	0.0%	98.6%	0.0%	0.0%	100.0%	98.0%	100.0%	0.0%	98.8%	0.0%	0.0%	98.0%
Trucks	0	1	0	0	1	0	0	0	0	0	0	0	0	0	0	1	0	0	1	0	0	0	0	0	0	0	0	0	2
% Trucks	0.0%	0.4%	0.0%	0.0%	0.4%	0.0%	0.0%	0.0%	0.0%	0.0%	0.0%	0.0%	0.0%	0.0%	0.0%	0.4%	0.0%	0.0%	0.4%	0.0%	0.0%	0.0%	0.0%	0.0%	0.0%	0.0%	0.0%	0.0%	0.3%
Buses	1	7	0	0	8	0	0	0	0	0	0	0	0	0	0	2	0	0	2	0	0	0	1	0	0	1	0	0	11
% Buses	2.8%	3.1%	0.0%	0.0%	0.0%	0.0%	0.0%	0.0%	0.0%	0.0%	0.0%	0.0%	0.0%	0.0%	0.0%	0.8%	0.0%	0.0%	0.0%	0.0%	0.0%	0.0%	2.0%	0.0%	0.0%	0.0%	0.0%	0.0%	1.6%
Pedestrians	0	0	0	0	0	0	0	0	0	0	0	0	0	0	0	0	0	1	0	0	0	0	0	0	0	4	4	0	
% Pedestrians	0.0%	0.0%	0.0%	0.0%	0.0%	0.0%	0.0%	0.0%	0.0%	0.0%	0.0%	0.0%	0.0%	0.0%	0.0%	0.0%	0.0%	0.0%	0.0%	0.0%	0.0%	0.0%	0.0%	0.0%	0.0%	0.0%	0.0%	0.0%	100.0%
Bicycles on Crosswalk	0	0	0	0	0	0	0	0	0	0	0	0	0	0	0	0	0	0	0	0	0	0	0	0	0	0	2	0	
% Bicycles on Crosswalk	0.0%	0.0%	0.0%	0.0%	0.0%	0.0%	0.0%	0.0%	0.0%	0.0%	0.0%	0.0%	0.0%	0.0%	0.0%	0.0%	0.0%	0.0%	0.0%	0.0%	0.0%	0.0%	0.0%	0.0%	0.0%	0.0%	0.0%	0.0%	33.3%

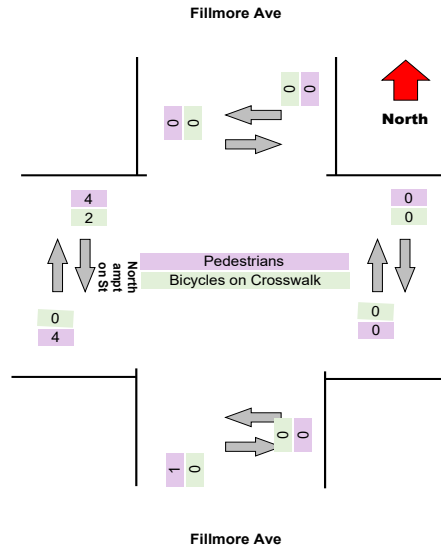
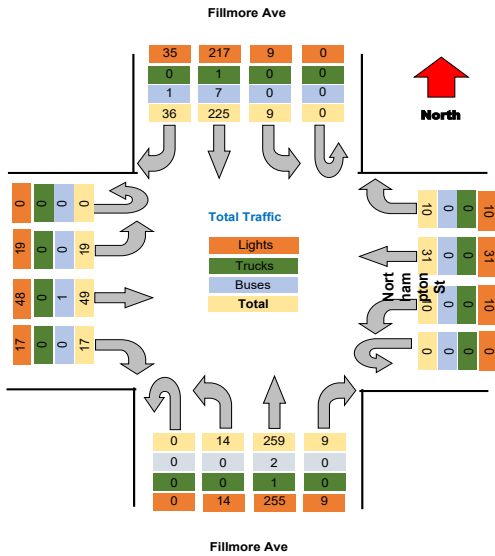

Project : VBH Malta NY
 Site : Site 4
 Location : 42.948550, -73.790036

TSTData.com

Survey Date : 2021-04-28, Wednesday

Project	LaBella
Project Code	LaBella
Site Name	19
Legs and Movements	All Processed Legs & Move
Bin Size	15 minutes
Survey Date	2021-11-03, Wednesday
Location	19
Latitude and Longitude	42.907282, -78.839084

	Start	End	PHF
Forced Peak AM	2021/11/03 07:30:00	2021/11/03 08:30:00	0.85
Forced Peak PM	2021/11/03 16:30:00	2021/11/03 17:30:00	0.89
AM Peak	2021/11/03 07:30:00	2021/11/03 08:30:00	0.85
PM Peak	2021/11/03 16:15:00	2021/11/03 17:15:00	0.9

Turning Movement Data

Leg Direction	Fillmore Ave Southbound						Northampton St Westbound						Fillmore Ave Northbound						Northampton St Eastbound						Total				
	Right	Thru	Left	U-Turn	App Total	Peds CCV	Right	Thru	Left	U-Turn	App Total	Peds CCV	Right	Thru	Left	U-Turn	App Total	Peds CCV	Right	Thru	Left	U-Turn	App Total	Peds CCV					
Start Time																													
6:30:00 AM	1	19	2	0	22	0	0	0	2	0	0	2	1	1	2	18	1	0	23	0	1	1	2	1	0	4	0	0	51
6:45:00 AM	7	16	1	0	24	0	0	1	6	1	0	8	0	0	0	20	0	0	20	0	0	1	3	1	0	5	0	1	57
Hourly Total	8	35	3	0	46	0	0	1	8	1	0	10	1	1	2	38	1	0	43	0	1	2	5	2	0	9	0	1	108
7:00:00 AM	5	31	1	0	37	1	0	0	9	0	0	9	1	0	3	23	0	0	27	1	0	1	6	1	0	8	0	0	77
7:15:00 AM	6	27	3	0	36	0	2	1	5	2	0	10	3	8	4	27	1	0	43	0	0	1	8	1	0	10	0	2	99
7:30:00 AM	6	38	2	0	46	3	0	4	5	2	0	11	1	4	7	36	2	0	50	0	1	2	9	1	0	12	0	1	119
7:45:00 AM	11	56	4	0	71	7	1	6	7	4	0	18	0	6	6	51	2	0	65	0	0	0	15	3	0	18	0	1	172
Hourly Total	28	152	10	0	190	11	3	11	22	8	0	44	5	18	20	137	5	0	185	1	1	4	38	6	0	48	0	4	467
8:00:00 AM	9	50	7	0	66	0	0	3	3	1	0	7	0	1	4	42	4	0	51	0	0	2	15	2	0	19	1	0	143
8:15:00 AM	12	54	3	0	69	1	0	1	7	1	0	9	2	2	1	49	5	0	59	0	1	0	9	5	0	14	0	0	151
Hourly Total	21	104	10	0	135	1	0	4	10	2	0	16	2	3	5	91	9	0	110	0	1	2	24	7	0	33	1	0	294
4:00:00 PM	3	67	2	0	72	0	0	4	8	1	0	13	0	0	2	72	5	0	79	0	0	5	15	2	0	22	0	1	186
4:15:00 PM	5	66	3	0	74	1	0	1	11	3	0	15	0	0	4	70	6	0	80	0	0	2	13	8	0	23	0	1	192
4:30:00 PM	9	72	4	0	85	0	0	2	12	0	0	14	0	0	4	61	8	0	73	2	2	7	16	5	0	28	1	5	200
4:45:00 PM	5	79	2	0	86	1	0	4	12	3	0	19	1	2	2	83	3	0	88	0	0	5	17	5	0	27	3	0	220
Hourly Total	22	284	11	0	317	2	0	11	43	7	0	61	1	2	12	236	22	0	320	2	2	19	61	20	0	100	3	7	798
5:00:00 PM	10	61	4	0	75	0	0	2	9	4	0	15	0	0	1	66	1	0	68	0	0	5	17	3	0	25	1	1	183
5:15:00 PM	8	69	1	0	78	0	0	2	10	2	0	14	1	1	0	52	4	0	56	0	0	3	19	10	0	32	1	2	180
5:30:00 PM	6	65	4	0	75	0	0	3	8	3	0	14	0	0	0	57	5	0	62	0	0	4	13	8	0	25	0	0	176
5:45:00 PM	6	59	2	0	67	0	0	3	8	0	0	11	1	2	1	51	7	0	59	0	0	4	10	5	0	19	0	3	156
Hourly Total	30	254	11	0	295	0	0	10	35	9	0	54	2	3	2	226	17	0	245	0	0	16	59	26	0	101	2	6	695
Grand Total	109	829	45	0	983	15	3	37	118	27	0	185	11	27	41	778	54	0	903	3	5	43	187	61	0	291	6	18	2382
% Approach	11.1%	84.3%	4.6%	0.0%	0.0%	0.0%	0.0%	20.0%	63.8%	14.6%	0.0%	0.0%	0.0%	0.0%	4.5%	86.2%	6.0%	0.0%	0.0%	0.0%	0.0%	14.8%	64.3%	21.0%	0.0%	0.0%	0.0%	0.0%	0.0%
% Total	4.6%	35.1%	1.9%	0.0%	41.6%	0.0%	0.0%	1.6%	5.0%	1.1%	0.0%	7.8%	0.0%	0.0%	1.7%	32.9%	2.3%	0.0%	38.2%	0.0%	0.0%	1.8%	7.9%	2.6%	0.0%	12.3%	0.0%	0.0%	0.0%
Lights	103	777	38	0	918	0	0	36	112	25	0	173	0	0	37	719	43	0	799	0	0	43	181	59	0	283	0	0	2173
% Lights	94.5%	93.7%	84.4%	0.0%	93.4%	0.0%	0.0%	97.3%	94.9%	92.6%	0.0%	93.5%	0.0%	0.0%	99.2%	92.4%	79.6%	0.0%	88.5%	0.0%	0.0%	100.0%	96.8%	96.7%	0.0%	97.3%	0.0%	0.0%	92.0%
Trucks	0	2	0	0	2	0	0	0	0	0	0	0	0	0	0	2	0	0	2	0	0	0	0	0	0	0	0	0	4
% Trucks	0.0%	0.2%	0.0%	0.0%	0.2%	0.0%	0.0%	0.0%	0.0%	0.0%	0.0%	0.0%	0.0%	0.0%	0.0%	0.3%	0.0%	0.0%	0.2%	0.0%	0.0%	0.0%	0.0%	0.0%	0.0%	0.0%	0.0%	0.0%	0.2%
Buses	6	50	7	0	63	0	0	1	6	2	0	9	0	0	4	56	11	0	71	0	0	0	6	2	0	8	0	0	151
% Buses	5.5%	6.0%	15.6%	0.0%	0.0%	0.0%	0.0%	0.0%	5.1%	7.4%	0.0%	0.0%	0.0%	0.0%	9.8%	7.2%	20.4%	0.0%	0.0%	0.0%	0.0%	0.0%	3.2%	3.3%	0.0%	0.0%	0.0%	0.0%	6.4%
Pedestrians	0	0	0	0	0	14	3	0	0	0	0	0	10	34	0	0	0	0	0	3	5	0	0	0	0	0	6	16	0
% Pedestrians	0.0%	0.0%	0.0%	0.0%	0.0%	83.3%	100.0%	0.0%	0.0%	0.0%	0.0%	0.0%	80.9%	88.9%	0.0%	0.0%	0.0%	0.0%	0.0%	100.0%	100.0%	0.0%	0.0%	0.0%	0.0%	0.0%	100.0%	100.0%	0.0%
Bicycles on Crosswalk	0	0	0	0	0	1	0	0	0	0	0	0	1	3	0	0	0	0	0	0	0	0	0	0	0	0	0	0	0
% Bicycles on Crosswalk	0.0%	0.0%	0.0%	0.0%	0.0%	6.7%	0.0%	0.0%	0.0%	0.0%	0.0%	0.0%	8.1%	11.1%	0.0%	0.0%	0.0%	0.0%	0.0%	0.0%	0.0%	0.0%	0.0%	0.0%	0.0%	0.0%	0.0%	0.0%	0.0%

Turning Movement Data Plot

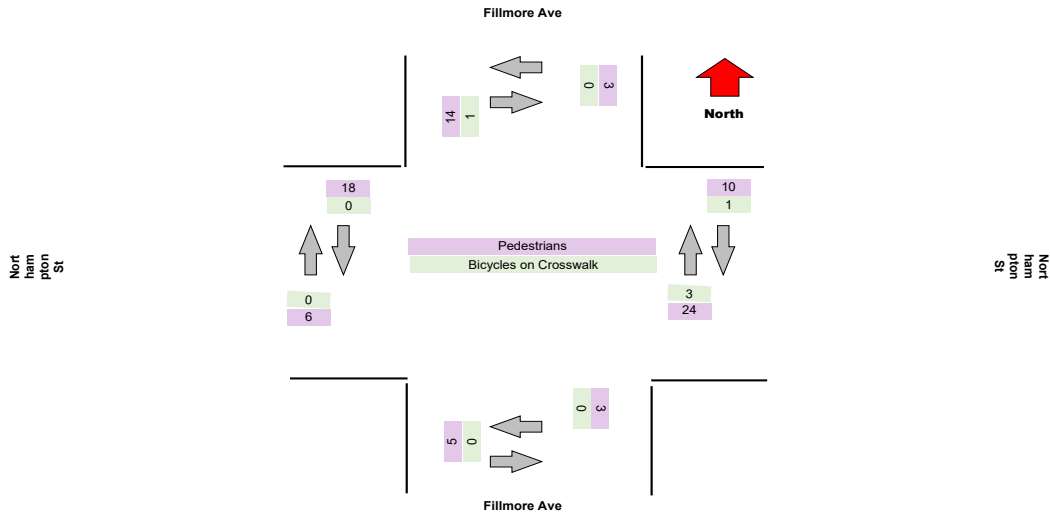
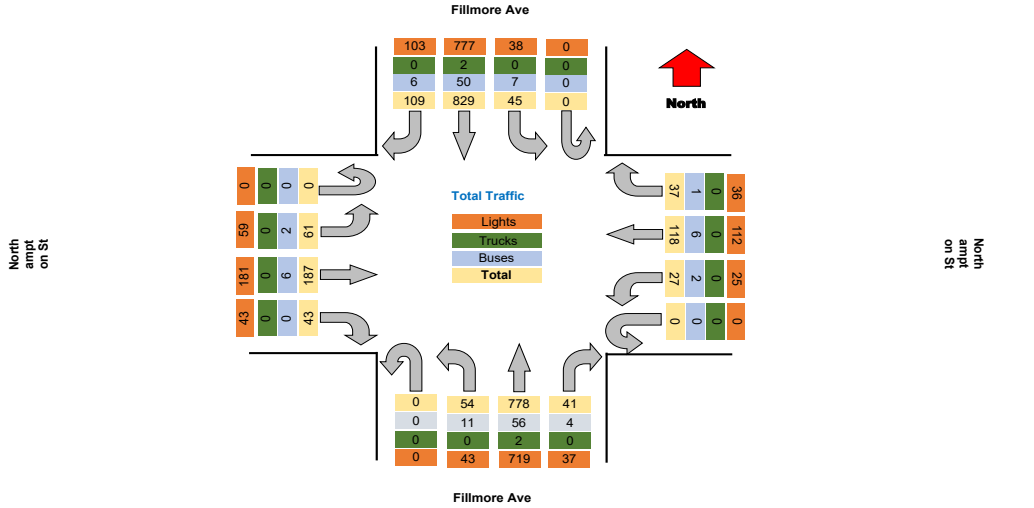

Turning Movement Peak Hour Data (AM)

7:30:00 AM

Leg Direction	Fillmore Ave						Northampton St						Fillmore Ave						Northampton St						Total					
	Southbound			Westbound			Northbound			Eastbound			Southbound			Westbound			Northbound			Eastbound								
Start Time	Right	Thru	Left	U-Turn	App Total	Peds CW	Peds CCW	Right	Thru	Left	U-Turn	App Total	Peds CW	Peds CCW	Right	Thru	Left	U-Turn	App Total	Peds CW	Peds CCW	Right	Thru	Left	U-Turn	App Total	Peds CW	Peds CCW		
7:30:00 AM	6	38	2	0	46	3	0	4	5	2	0	11	1	4	7	36	2	0	50	0	1	2	9	1	0	12	0	1	119	
7:45:00 AM	11	56	4	0	71	7	1	6	7	4	0	18	0	6	6	51	2	0	65	0	0	0	15	3	0	18	0	1	172	
8:00:00 AM	9	50	7	0	66	0	0	3	3	1	0	7	0	1	4	42	4	0	51	0	0	2	15	2	0	19	1	0	143	
8:15:00 AM	12	54	3	0	69	4	0	1	7	1	0	9	2	2	1	49	5	0	59	0	1	0	9	5	0	14	0	0	151	
Grand Total	38	198	16	0	252	11	1	14	22	8	0	45	3	13	18	178	13	0	235	0	2	4	46	11	0	63	1	2	585	
% Approach	15.1%	78.6%	6.3%	0.0%	0.0%	0.0%	0.0%	31.1%	48.9%	17.8%	0.0%	0.0%	0.0%	0.0%	8.0%	79.1%	5.8%	0.0%	0.0%	0.0%	0.0%	6.3%	76.2%	17.5%	0.0%	0.0%	0.0%	0.0%	0.0%	
% Total	6.5%	33.8%	2.7%	0.0%	43.1%	0.0%	0.0%	2.4%	3.8%	1.4%	0.0%	7.7%	0.0%	0.0%	3.1%	30.4%	2.2%	0.0%	38.5%	0.0%	0.0%	0.7%	8.2%	1.9%	0.0%	10.8%	0.0%	0.0%	0.0%	
PHF	0.792	0.884	0.571	0.000	0.887	0.000	0.000	0.583	0.786	0.500	0.000	0.625	0.000	0.000	0.643	0.873	0.650	0.000	0.865	0.000	0.000	0.500	0.800	0.550	0.000	0.829	0.000	0.000	0.850	
Lights	37	182	12	0	231	0	0	14	20	8	0	42	0	0	17	156	8	0	181	0	0	4	46	11	0	61	0	0	515	
% Lights	87.4%	91.9%	75.0%	0.0%	91.7%	0.0%	0.0%	100.0%	90.9%	100.0%	0.0%	93.3%	0.0%	0.0%	94.4%	87.6%	61.5%	0.0%	80.4%	0.0%	0.0%	100.0%	95.8%	100.0%	0.0%	96.8%	0.0%	0.0%	88.0%	
Trucks	0	0	0	0	0	0	0	0	0	0	0	0	0	0	0	0	0	0	0	0	0	0	0	0	0	0	0	0	0	
% Trucks	0.0%	0.0%	0.0%	0.0%	0.0%	0.0%	0.0%	0.0%	0.0%	0.0%	0.0%	0.0%	0.0%	0.0%	0.0%	0.0%	0.0%	0.0%	0.0%	0.0%	0.0%	0.0%	0.0%	0.0%	0.0%	0.0%	0.0%	0.0%	0.0%	
Buses	1	16	4	0	21	0	0	0	2	0	0	2	0	0	1	22	5	0	28	0	0	0	2	0	0	2	0	0	53	
% Buses	2.6%	8.1%	25.0%	0.0%	0.0%	0.0%	0.0%	0.0%	9.1%	0.0%	0.0%	0.0%	0.0%	0.0%	5.6%	12.4%	38.5%	0.0%	0.0%	0.0%	0.0%	4.2%	0.0%	0.0%	0.0%	0.0%	0.0%	0.0%	9.1%	
Pedestrians	0	0	0	0	0	11	1	0	0	0	0	0	3	13	0	0	0	0	0	0	2	0	0	0	0	0	0	1	2	0
% Pedestrians	0.0%	0.0%	0.0%	0.0%	0.0%	100.0%	100.0%	0.0%	0.0%	0.0%	0.0%	0.0%	100.0%	100.0%	0.0%	0.0%	0.0%	0.0%	0.0%	0.0%	100.0%	0.0%	0.0%	0.0%	0.0%	0.0%	0.0%	100.0%	100.0%	0.0%
Bicycles on Crosswalk	0	0	0	0	0	0	0	0	0	0	0	0	0	0	0	0	0	0	0	0	0	0	0	0	0	0	0	0	0	
% Bicycles on Crosswalk	0.0%	0.0%	0.0%	0.0%	0.0%	0.0%	0.0%	0.0%	0.0%	0.0%	0.0%	0.0%	0.0%	0.0%	0.0%	0.0%	0.0%	0.0%	0.0%	0.0%	0.0%	0.0%	0.0%	0.0%	0.0%	0.0%	0.0%	0.0%	0.0%	

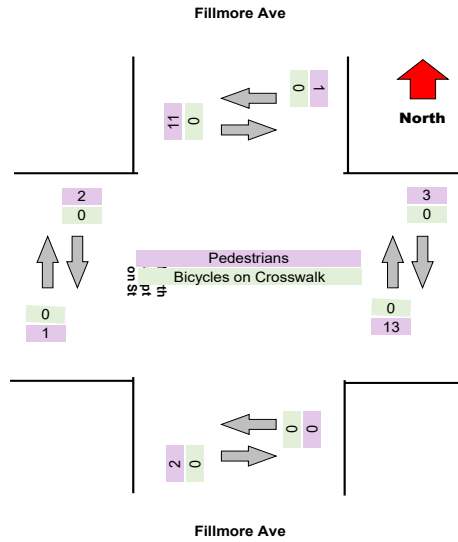
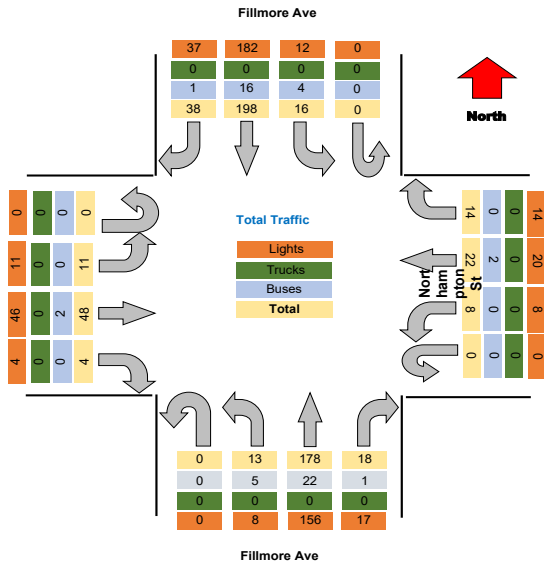

Turning Movement Peak Hour Data (PM)

4:15:00 PM

Leg Direction	Fillmore Ave								Northampton St								Fillmore Ave								Northampton St								Total
	Southbound				Northbound				Westbound				Eastbound				Northbound				Eastbound												
	Right	Thru	Left	U-Turn	App Total	Peds CW	Peds CCW		Right	Thru	Left	U-Turn	App Total	Peds CW	Peds CCW		Right	Thru	Left	U-Turn	App Total	Peds CW	Peds CCW		Right	Thru	Left	U-Turn	App Total	Peds CW	Peds CCW		
4:15:00 PM	5	66	3	0	74	1	0	0	1	11	3	0	15	0	0	0	4	70	6	0	80	0	0	0	2	13	8	0	23	0	1	0	192
4:30:00 PM	9	72	4	0	85	0	0	0	2	12	0	0	14	0	0	0	4	61	8	0	73	2	2	0	7	16	5	0	28	1	5	0	200
4:45:00 PM	5	79	2	0	86	1	0	0	4	12	3	0	19	1	2	0	2	83	3	0	88	0	0	0	5	17	5	0	27	2	0	0	220
5:00:00 PM	10	61	4	0	75	0	0	0	2	9	4	0	15	0	0	0	1	66	1	0	68	0	0	0	5	17	3	0	25	1	1	0	183
Grand Total	29	278	13	0	320	2	0	0	9	44	10	0	53	1	2	0	11	290	16	0	329	2	2	0	19	63	21	0	103	4	7	0	795
% Approach	9.1%	86.9%	4.1%	0.0%	0.0%	0.0%	0.0%	0.0%	14.3%	69.8%	15.9%	0.0%	0.0%	0.0%	0.0%	0.0%	3.6%	90.6%	5.8%	0.0%	0.0%	0.0%	0.0%	0.0%	18.4%	61.2%	20.4%	0.0%	0.0%	0.0%	0.0%	0.0%	
% Total	3.6%	35.0%	1.6%	0.0%	40.3%	0.0%	0.0%	0.0%	1.1%	5.5%	1.3%	0.0%	7.9%	0.0%	0.0%	0.0%	1.4%	35.2%	2.3%	0.0%	38.9%	0.0%	0.0%	0.0%	2.4%	7.9%	2.6%	0.0%	13.0%	0.0%	0.0%	0.0%	
PHF	0.725	0.880	0.613	0.000	0.930	0.000	0.000	0.000	0.563	0.917	0.625	0.000	0.829	0.000	0.000	0.000	0.688	0.843	0.563	0.000	0.878	0.000	0.000	0.000	0.679	0.926	0.656	0.000	0.920	0.000	0.000	0.000	0.903
Lights	27	261	10	0	298	0	0	0	9	42	10	0	61	0	0	0	10	271	15	0	296	0	0	0	19	62	21	0	102	0	0	0	757
% Lights	93.1%	93.9%	76.9%	0.0%	93.1%	0.0%	0.0%	0.0%	100.0%	95.5%	100.0%	0.0%	96.8%	0.0%	0.0%	0.0%	90.9%	96.8%	83.3%	0.0%	95.8%	0.0%	0.0%	0.0%	100.0%	98.4%	100.0%	0.0%	99.0%	0.0%	0.0%	0.0%	
Trucks	0	1	0	0	1	0	0	0	0	0	0	0	0	0	0	0	0	0	0	0	0	0	0	0	0	0	0	0	0	0	0	0	1
% Trucks	0.0%	0.4%	0.0%	0.0%	0.3%	0.0%	0.0%	0.0%	0.0%	0.0%	0.0%	0.0%	0.0%	0.0%	0.0%	0.0%	0.0%	0.0%	0.0%	0.0%	0.0%	0.0%	0.0%	0.0%	0.0%	0.0%	0.0%	0.0%	0.0%	0.0%	0.0%	0.0%	
Buses	2	16	3	0	21	0	0	0	0	2	0	0	2	0	0	0	1	9	3	0	13	0	0	0	0	1	0	0	1	0	0	0	37
% Buses	6.9%	5.8%	23.1%	0.0%	0.0%	0.0%	0.0%	0.0%	0.0%	4.5%	0.0%	0.0%	0.0%	0.0%	0.0%	0.0%	9.1%	3.2%	16.7%	0.0%	0.0%	0.0%	0.0%	0.0%	0.0%	1.6%	0.0%	0.0%	0.0%	0.0%	0.0%	0.0%	4.7%
Pedestrians	0	0	0	0	0	1	0	0	0	0	0	0	1	1	0	0	0	0	0	0	2	2	0	0	0	0	0	0	0	4	7	0	7
% Pedestrians	0.0%	0.0%	0.0%	0.0%	0.0%	50.0%	0.0%	0.0%	0.0%	0.0%	0.0%	0.0%	0.0%	100.0%	50.0%	0.0%	0.0%	0.0%	0.0%	0.0%	0.0%	100.0%	100.0%	0.0%	0.0%	100.0%	100.0%	0.0%	0.0%				
Bicycles on Crosswalk	0	0	0	0	0	1	0	0	0	0	0	0	0	1	0	0	0	0	0	0	0	0	0	0	0	0	0	0	0	0	0	0	0
% Bicycles on Crosswalk	0.0%	0.0%	0.0%	0.0%	0.0%	50.0%	0.0%	0.0%	0.0%	0.0%	0.0%	0.0%	0.0%	0.0%	50.0%	0.0%	0.0%	0.0%	0.0%	0.0%	0.0%	0.0%	0.0%	0.0%	0.0%	0.0%	0.0%	0.0%	0.0%	0.0%	0.0%	0.0%	

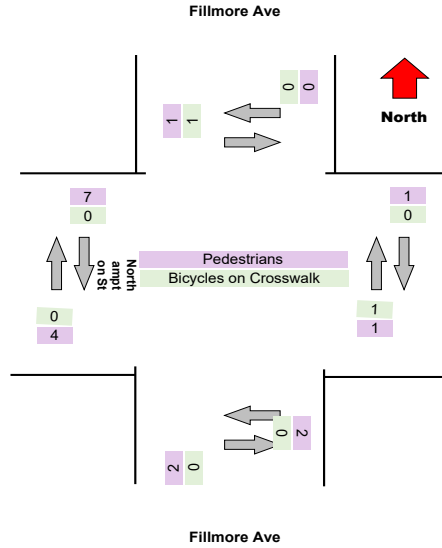
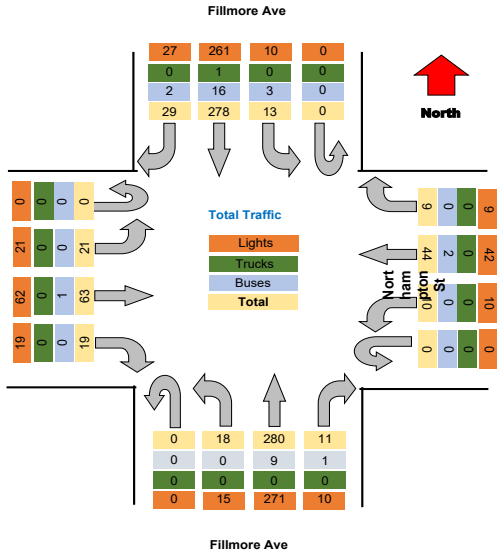

Project : VBH Malta NY
 Site : Site 4
 Location : 42.948550, -73.790036

TSTData.com

Survey Date : 2021-04-28, Wednesday

Project	LaBella
Project Code	LaBella
Site Name	19
Legs and Movements	All Processed Legs & Move
Bin Size	15 minutes
Survey Date	2021-11-04, Thursday
Location	19
Latitude and Longitude	42.907282, -78.839084

	Start	End	PHF
Forced Peak AM	2021/11/04 07:30:00	2021/11/04 08:30:00	0.92
Forced Peak PM	2021/11/04 16:30:00	2021/11/04 17:30:00	0.92
AM Peak	2021/11/04 07:30:00	2021/11/04 08:30:00	0.92
PM Peak	2021/11/04 16:15:00	2021/11/04 17:15:00	0.93

Turning Movement Data

Leg Direction	Fillmore Ave							Genesee St							Fillmore Ave							Genesee St							Total
	Southbound							Westbound							Northbound							Eastbound							
	Right	Thru	Left	U-Turn	App Total	Peds CV	Peds CCV	Right	Thru	Left	U-Turn	App Total	Peds CV	Peds CCV	Right	Thru	Left	U-Turn	App Total	Peds CV	Peds CCV	Right	Thru	Left	U-Turn	App Total	Peds CV	Peds CCV	
6:30:00 AM	2	19	1	0	22	0	0	0	1	0	0	2	0	1	2	10	0	0	13	0	1	0	1	0	0	1	0	0	38
6:45:00 AM	3	23	1	0	27	0	0	0	4	0	0	4	0	0	0	16	0	0	16	0	0	2	3	0	0	5	0	0	52
Hourly Total	5	42	2	0	49	0	0	0	5	1	0	6	0	1	2	26	0	0	29	0	1	2	4	0	0	6	0	0	99
7:00:00 AM	5	25	2	0	32	2	1	0	6	0	0	7	3	1	3	21	1	0	29	0	0	0	2	0	0	2	0	0	70
7:15:00 AM	5	22	1	0	28	0	1	1	5	0	0	7	4	4	5	23	1	0	37	0	0	3	10	2	0	15	1	1	87
7:30:00 AM	11	46	5	0	62	3	0	1	7	4	0	12	0	7	7	30	1	0	45	0	0	1	9	1	0	11	0	0	130
7:45:00 AM	9	47	3	0	59	3	2	3	10	3	0	18	0	7	6	39	1	0	53	0	0	1	19	5	0	25	0	2	155
Hourly Total	30	140	11	0	181	8	4	5	28	7	0	44	7	19	21	113	4	0	164	0	0	5	40	8	0	53	1	3	442
8:00:00 AM	12	67	6	0	85	1	0	3	4	2	0	9	2	4	2	44	3	0	55	0	0	4	14	2	0	20	0	0	169
8:15:00 AM	7	61	8	0	76	0	0	1	9	2	0	12	1	2	3	46	3	0	55	0	0	3	12	8	0	23	0	0	166
Hourly Total	19	128	14	0	161	1	0	4	13	4	0	21	3	6	5	90	6	0	110	0	0	7	26	10	0	43	0	0	335
4:00:00 PM	6	68	1	0	75	0	0	3	8	4	0	15	0	2	2	72	3	0	77	1	0	4	16	7	0	27	0	0	194
4:15:00 PM	9	84	2	0	95	0	0	1	9	2	0	12	0	1	2	71	6	0	79	0	1	3	25	2	0	30	2	1	216
4:30:00 PM	12	55	4	0	71	1	0	5	9	4	0	18	1	2	3	78	4	0	85	1	0	6	15	5	0	26	0	1	200
4:45:00 PM	13	62	0	0	75	0	0	4	9	4	0	17	0	3	1	74	5	0	80	0	0	5	17	8	0	30	1	0	222
Hourly Total	40	289	7	0	336	1	0	13	35	14	0	62	1	8	8	295	18	0	321	2	1	18	73	22	0	113	3	2	832
5:00:00 PM	8	65	0	0	73	0	0	4	5	3	0	12	2	2	2	75	3	0	80	0	0	6	23	3	0	32	0	1	187
5:15:00 PM	7	75	3	0	85	0	0	2	9	4	0	15	0	0	2	74	4	0	80	0	0	7	22	2	0	31	2	0	211
5:30:00 PM	9	67	1	0	77	0	0	3	8	1	0	12	0	0	2	55	3	0	60	0	0	7	15	1	0	23	0	2	172
5:45:00 PM	14	60	2	0	76	0	0	5	7	0	0	12	2	0	1	52	3	0	56	0	0	5	16	3	0	24	0	0	168
Hourly Total	38	257	6	0	301	0	1	14	29	8	0	51	4	2	7	256	13	0	276	0	0	25	76	9	0	110	2	3	738
Grand Total	132	856	40	0	1028	10	5	36	110	34	0	184	15	38	43	780	41	0	900	2	2	57	219	49	0	325	6	10	2437
% Approach	12.8%	83.3%	3.9%	0.0%	0.0%	0.0%	0.0%	19.6%	59.8%	18.5%	0.0%	0.0%	0.0%	0.0%	4.8%	86.7%	4.6%	0.0%	0.0%	0.0%	0.0%	17.5%	67.4%	15.1%	0.0%	0.0%	0.0%	0.0%	0.0%
% Total	5.4%	35.1%	1.6%	0.0%	42.2%	0.0%	0.0%	1.5%	4.5%	1.4%	0.0%	7.6%	0.0%	0.0%	1.8%	32.0%	1.7%	0.0%	36.9%	0.0%	0.0%	2.3%	9.0%	2.0%	0.0%	13.3%	0.0%	0.0%	0.0%
Lights	127	806	32	0	965	0	0	35	106	34	0	175	0	0	40	727	33	0	800	0	0	55	215	47	0	317	0	0	2287
% Lights	96.2%	94.2%	80.0%	0.0%	93.9%	0.0%	0.0%	97.2%	96.4%	100.0%	0.0%	95.1%	0.0%	0.0%	93.0%	93.2%	80.5%	0.0%	88.9%	0.0%	0.0%	96.5%	98.2%	95.9%	0.0%	97.8%	0.0%	0.0%	92.6%
Trucks	0	2	0	0	2	0	0	0	0	0	0	0	0	0	0	1	0	0	1	0	0	0	0	0	0	0	0	0	3
% Trucks	0.0%	0.2%	0.0%	0.0%	0.2%	0.0%	0.0%	0.0%	0.0%	0.0%	0.0%	0.0%	0.0%	0.0%	0.0%	0.1%	0.0%	0.0%	0.1%	0.0%	0.0%	0.0%	0.0%	0.0%	0.0%	0.0%	0.0%	0.0%	0.1%
Buses	5	48	8	0	61	0	0	1	4	0	0	5	0	0	3	52	8	0	63	0	0	2	4	2	0	8	0	0	137
% Buses	3.8%	5.6%	20.0%	0.0%	0.0%	0.0%	0.0%	0.0%	3.6%	0.0%	0.0%	0.0%	0.0%	0.0%	7.0%	6.7%	19.5%	0.0%	0.0%	0.0%	0.0%	3.5%	1.8%	4.1%	0.0%	0.0%	0.0%	0.0%	5.6%
Pedestrians	0	0	0	0	0	10	5	0	0	0	0	0	13	38	0	0	0	0	0	2	2	0	0	0	0	0	6	9	0
% Pedestrians	0.0%	0.0%	0.0%	0.0%	0.0%	100.0%	100.0%	0.0%	0.0%	0.0%	0.0%	0.0%	86.7%	100.0%	0.0%	0.0%	0.0%	0.0%	0.0%	100.0%	100.0%	0.0%	0.0%	0.0%	0.0%	0.0%	100.0%	80.0%	0.0%
Bicycles on Crosswalk	0	0	0	0	0	0	0	0	0	0	0	0	2	0	0	0	0	0	0	0	0	0	0	0	0	0	0	1	0
% Bicycles on Crosswalk	0.0%	0.0%	0.0%	0.0%	0.0%	0.0%	0.0%	0.0%	0.0%	0.0%	0.0%	0.0%	13.3%	0.0%	0.0%	0.0%	0.0%	0.0%	0.0%	0.0%	0.0%	0.0%	0.0%	0.0%	0.0%	0.0%	0.0%	10.0%	0.0%

Project : VBH Malta NY
 Site : Site 4
 Location : 42.948550, -73.790036
 Survey Date : 2021-04-28, Wednesday

Turning Movement Data Plot

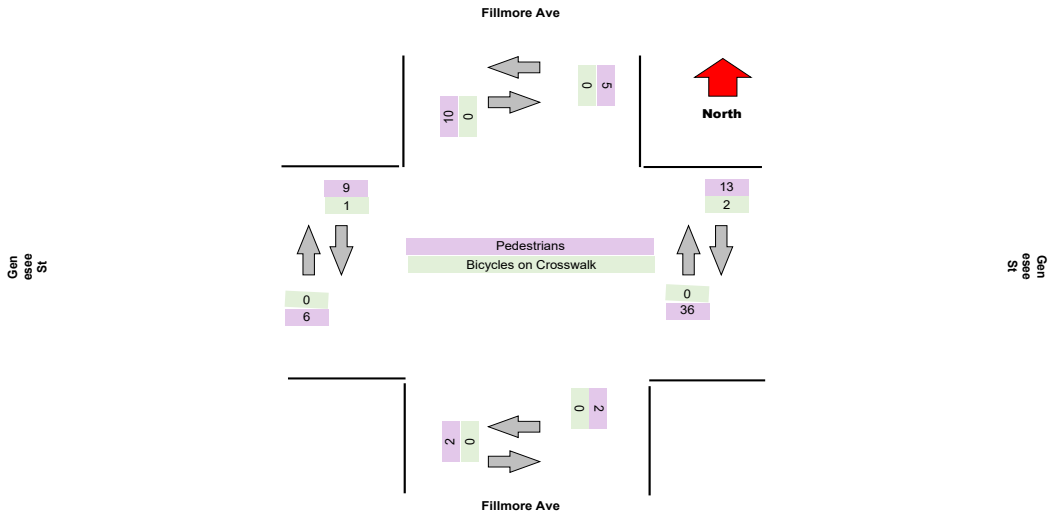
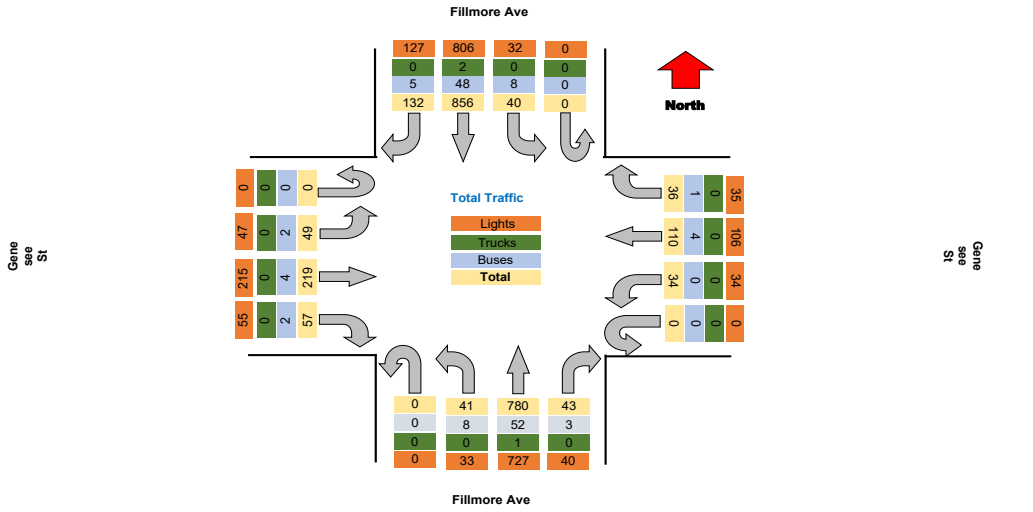

Project : VBH Malta NY
Site : Site 4
Location : 42.948550, -73.790036

TSTData.com

Survey Date : 2021-04-28, Wednesday

Turning Movement Peak Hour Data (AM)

7:30:00 AM

Leg Direction	Fillmore Ave						Genesee St						Fillmore Ave						Genesee St						Total				
	Southbound			Northbound			Westbound			Eastbound			Northbound			Eastbound													
Start Time	Right	Thru	Left	U-Turn	App Total	Peds CW	Peds CCW	Right	Thru	Left	U-Turn	App Total	Peds CW	Peds CCW	Right	Thru	Left	U-Turn	App Total	Peds CW	Peds CCW	Right	Thru	Left	U-Turn	App Total	Peds CW	Peds CCW	
7:30:00 AM	11	46	5	0	62	3	0	1	7	4	0	12	0	7	7	30	1	0	45	0	0	1	9	1	0	11	0	0	130
7:45:00 AM	9	47	3	0	59	3	2	3	10	3	0	16	0	7	6	39	1	0	53	0	0	1	19	5	0	25	0	2	165
8:00:00 AM	12	67	6	0	85	1	0	3	4	2	0	9	2	4	2	44	3	0	55	0	0	4	14	2	0	20	0	0	169
8:15:00 AM	7	61	8	0	76	0	0	1	9	2	0	12	1	2	3	46	3	0	55	0	0	3	12	8	0	23	0	0	166
Grand Total	39	221	22	0	282	7	2	8	30	11	0	31	3	20	18	159	8	0	238	0	0	9	54	16	0	79	3	2	620
% Approach	13.8%	78.4%	7.8%	0.0%	0.0%	0.0%	0.0%	15.7%	58.8%	21.6%	0.0%	0.0%	0.0%	0.0%	8.7%	76.4%	3.8%	0.0%	0.0%	0.0%	0.0%	11.4%	66.4%	20.3%	0.0%	0.0%	0.0%	0.0%	0.0%
% Total	6.3%	35.6%	3.5%	0.0%	45.5%	0.0%	0.0%	1.3%	4.8%	1.8%	0.0%	8.2%	0.0%	0.0%	2.9%	25.6%	1.3%	0.0%	33.5%	0.0%	0.0%	1.5%	8.7%	2.6%	0.0%	12.7%	0.0%	0.0%	0.0%
PHF	0.813	0.825	0.688	0.000	0.829	0.000	0.000	0.667	0.750	0.688	0.000	0.708	0.000	0.000	0.643	0.864	0.667	0.000	0.845	0.000	0.000	0.563	0.711	0.500	0.000	0.790	0.000	0.000	0.917
Lights	38	207	17	0	262	0	0	8	28	11	0	47	0	0	18	140	4	0	162	0	0	9	52	16	0	77	0	0	548
% Lights	97.4%	93.7%	77.3%	0.0%	92.9%	0.0%	0.0%	100.0%	93.3%	100.0%	0.0%	92.2%	0.0%	0.0%	100.0%	88.1%	50.0%	0.0%	77.9%	0.0%	0.0%	100.0%	96.3%	100.0%	0.0%	97.5%	0.0%	0.0%	88.4%
Trucks	0	0	0	0	0	0	0	0	0	0	0	0	0	0	0	0	0	0	0	0	0	0	0	0	0	0	0	0	0
% Trucks	0.0%	0.0%	0.0%	0.0%	0.0%	0.0%	0.0%	0.0%	0.0%	0.0%	0.0%	0.0%	0.0%	0.0%	0.0%	0.0%	0.0%	0.0%	0.0%	0.0%	0.0%	0.0%	0.0%	0.0%	0.0%	0.0%	0.0%	0.0%	0.0%
Buses	1	14	5	0	20	0	0	0	2	0	0	2	0	0	0	19	4	0	23	0	0	0	2	0	0	2	0	0	47
% Buses	2.6%	6.3%	22.7%	0.0%	0.0%	0.0%	0.0%	0.0%	6.7%	0.0%	0.0%	0.0%	0.0%	0.0%	0.0%	11.9%	50.0%	0.0%	0.0%	0.0%	0.0%	0.0%	3.7%	0.0%	0.0%	0.0%	0.0%	0.0%	7.6%
Pedestrians	0	0	0	0	0	7	2	0	0	0	0	3	20	0	0	0	0	0	0	0	0	0	0	0	0	0	0	1	0
% Pedestrians	0.0%	0.0%	0.0%	0.0%	0.0%	100.0%	100.0%	0.0%	0.0%	0.0%	0.0%	0.0%	100.0%	100.0%	0.0%	0.0%	0.0%	0.0%	0.0%	0.0%	0.0%	0.0%	0.0%	0.0%	0.0%	0.0%	0.0%	50.0%	0.0%
Bicycles on Crosswalk	0	0	0	0	0	0	0	0	0	0	0	0	0	0	0	0	0	0	0	0	0	0	0	0	0	0	0	1	0
% Bicycles on Crosswalk	0.0%	0.0%	0.0%	0.0%	0.0%	0.0%	0.0%	0.0%	0.0%	0.0%	0.0%	0.0%	0.0%	0.0%	0.0%	0.0%	0.0%	0.0%	0.0%	0.0%	0.0%	0.0%	0.0%	0.0%	0.0%	0.0%	50.0%	0.0%	

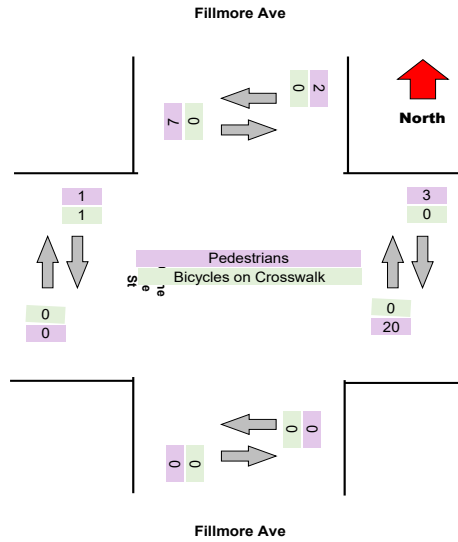
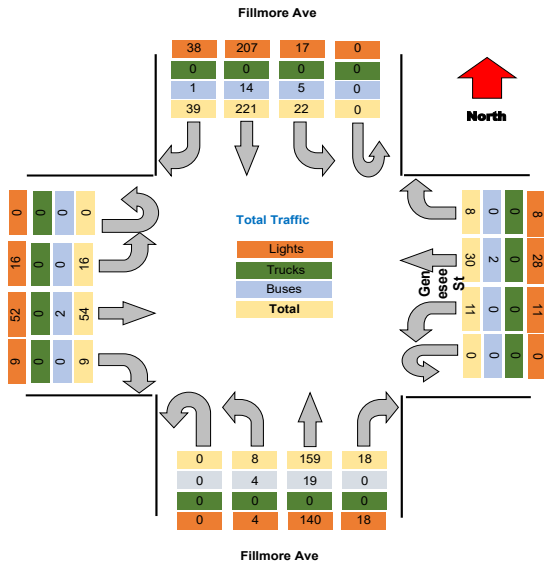

Turning Movement Peak Hour Data (PM)

4:15:00 PM

Leg Direction	Fillmore Ave										Genesee St										Total									
	Southbound					Westbound					Northbound					Eastbound														
	Right	Thru	Left	U-Turn	App Total	Peds CW	Peds CCW	Right	Thru	Left	U-Turn	App Total	Peds CW	Peds CCW	Right	Thru	Left	U-Turn	App Total	Peds CW		Peds CCW								
4:15:00 PM	9	84	2	0	95	0	0	1	9	2	0	12	0	1	2	71	6	0	79	0	1	3	25	2	0	30	2	1	216	
4:30:00 PM	12	55	4	0	71	1	0	5	9	4	0	18	1	2	3	78	4	0	85	1	0	6	15	5	0	26	0	1	200	
4:45:00 PM	13	82	0	0	95	0	0	4	9	4	0	17	0	3	1	74	5	0	80	0	0	5	17	8	0	30	1	0	222	
5:00:00 PM	8	55	0	0	63	0	0	4	5	3	0	12	2	2	2	75	3	0	80	0	0	6	23	3	0	32	0	1	187	
Grand Total	42	276	6	0	324	1	0	14	32	13	0	59	3	6	8	298	18	0	324	1	1	20	80	18	0	118	3	3	825	
% Approach	13.0%	85.2%	1.9%	0.0%	0.0%	0.0%	0.0%	23.7%	54.2%	22.0%	0.0%	0.0%	0.0%	0.0%	2.5%	92.0%	5.6%	0.0%	0.0%	0.0%	0.0%	16.9%	67.8%	15.3%	0.0%	0.0%	0.0%	0.0%	0.0%	
% Total	5.1%	33.5%	0.7%	0.0%	38.3%	0.0%	0.0%	1.7%	3.9%	1.6%	0.0%	7.2%	0.0%	0.0%	1.0%	36.1%	2.2%	0.0%	39.3%	0.0%	0.0%	2.4%	9.7%	2.2%	0.0%	14.3%	0.0%	0.0%	0.0%	
PHF	0.808	0.821	0.375	0.000	0.853	0.000	0.000	0.700	0.889	0.813	0.000	0.819	0.000	0.000	0.667	0.955	0.750	0.000	0.853	0.000	0.000	0.833	0.800	0.563	0.000	0.922	0.000	0.000	0.929	
Lights	42	260	4	0	306	0	0	14	32	13	0	59	0	0	7	286	14	0	307	0	0	20	79	18	0	117	0	0	789	
% Lights	100.0%	94.2%	66.7%	0.0%	94.4%	0.0%	0.0%	100.0%	100.0%	100.0%	0.0%	100.0%	0.0%	0.0%	87.5%	96.0%	77.8%	0.0%	94.8%	0.0%	0.0%	100.0%	98.8%	100.0%	0.0%	99.2%	0.0%	0.0%	95.6%	
Trucks	0	1	0	0	1	0	0	0	0	0	0	0	0	0	0	0	0	0	0	0	0	0	0	0	0	0	0	0	1	
% Trucks	0.0%	0.4%	0.0%	0.0%	0.3%	0.0%	0.0%	0.0%	0.0%	0.0%	0.0%	0.0%	0.0%	0.0%	0.0%	0.0%	0.0%	0.0%	0.0%	0.0%	0.0%	0.0%	0.0%	0.0%	0.0%	0.0%	0.0%	0.0%	0.1%	
Buses	0	15	2	0	17	0	0	0	0	0	0	0	0	0	1	12	4	0	17	0	0	0	1	0	0	1	0	0	35	
% Buses	0.0%	5.4%	33.3%	0.0%	0.0%	0.0%	0.0%	0.0%	0.0%	0.0%	0.0%	0.0%	0.0%	0.0%	12.5%	4.0%	22.2%	0.0%	0.0%	0.0%	0.0%	0.0%	1.3%	0.0%	0.0%	0.0%	0.0%	0.0%	4.2%	
Pedestrians	0	0	0	0	0	1	1	0	0	0	0	2	6	0	0	0	0	0	0	1	1	0	0	0	0	0	3	3	0	
% Pedestrians	0.0%	0.0%	0.0%	0.0%	0.0%	100.0%	100.0%	0.0%	0.0%	0.0%	0.0%	66.7%	100.0%	0.0%	0.0%	0.0%	0.0%	0.0%	0.0%	0.0%	100.0%	100.0%	0.0%	0.0%	0.0%	0.0%	0.0%	100.0%	100.0%	0.0%
Bicycles on Crosswalk	0	0	0	0	0	0	0	0	0	0	0	1	0	0	0	0	0	0	0	0	0	0	0	0	0	0	0	0	0	
% Bicycles on Crosswalk	0.0%	0.0%	0.0%	0.0%	0.0%	0.0%	0.0%	0.0%	0.0%	0.0%	0.0%	33.3%	0.0%	0.0%	0.0%	0.0%	0.0%	0.0%	0.0%	0.0%	0.0%	0.0%	0.0%	0.0%	0.0%	0.0%	0.0%	0.0%	0.0%	

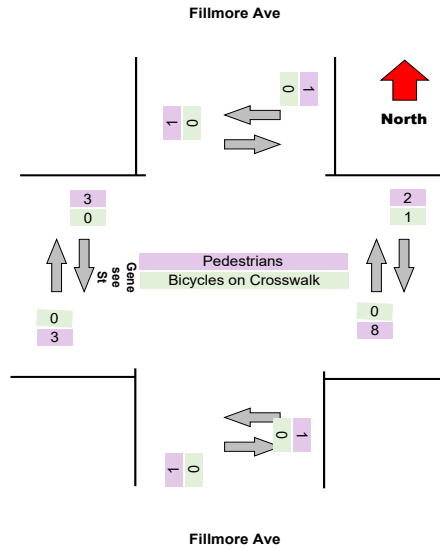
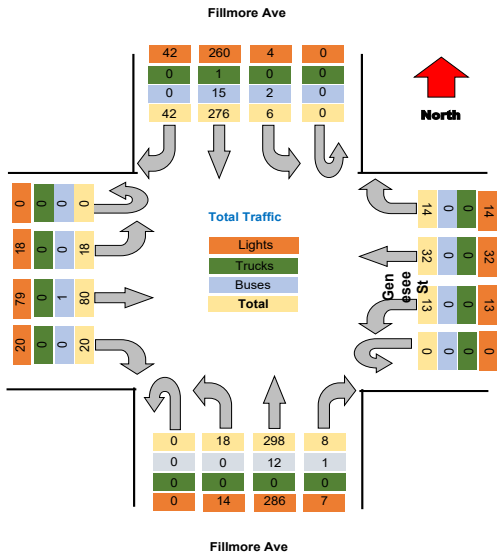

Turning Movement Data Plot

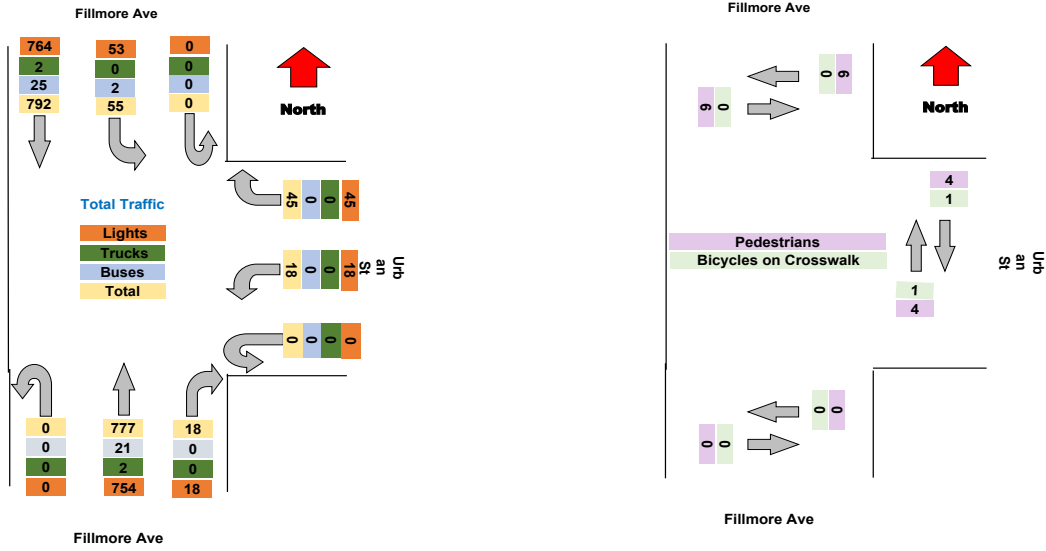

Turning Movement Peak Hour Data (AM)
 7:30:00 AM

Leg Direction	Fillmore Ave Southbound						Urban St Westbound						Fillmore Ave Northbound						Total
	Thru	Left	U-Turn	App Total	Peds CW	Peds CCW	Right	Left	U-Turn	App Total	Peds CW	Peds CCW	Right	Thru	U-Turn	App Total	Peds CW	Peds CCW	
7:30:00 AM	26	2	0	28	0	0	3	0	0	3	0	1	3	26	0	30	0	0	61
7:45:00 AM	42	5	0	47	0	0	1	0	0	1	0	0	1	37	0	38	0	0	86
8:00:00 AM	48	4	0	52	0	0	2	0	0	2	1	0	0	29	0	30	0	0	84
8:15:00 AM	45	2	0	47	0	0	5	1	0	6	0	0	1	28	0	29	0	0	82
Grand Total	161	13	0	174	0	0	11	1	0	12	1	1	5	120	0	127	0	0	313
% Approach	92.5%	7.5%	0.0%	0.0%	0.0%	0.0%	91.7%	8.3%	0.0%	0.0%	0.0%	0.0%	3.9%	94.5%	0.0%	0.0%	0.0%	0.0%	
% Total	51.4%	4.2%	0.0%	55.6%	0.0%	0.0%	3.5%	0.3%	0.0%	3.8%	0.0%	0.0%	1.6%	38.3%	0.0%	40.6%	0.0%	0.0%	
PHF	0.839	0.650	0.000	0.837	0.000	0.000	0.550	0.250	0.000	0.500	0.000	0.000	0.417	0.811	0.000	0.836	0.000	0.000	0.910
Lights	154	13	0	167	0	0	11	1	0	12	0	0	5	111	0	116	0	0	295
% Lights	95.7%	100.0%	0.0%	96.0%	0.0%	0.0%	100.0%	100.0%	0.0%	100.0%	0.0%	0.0%	100.0%	92.5%	0.0%	91.3%	0.0%	0.0%	94.2%
Trucks	0	0	0	0	0	0	0	0	0	0	0	0	0	0	0	0	0	0	0
% Trucks	0.0%	0.0%	0.0%	0.0%	0.0%	0.0%	0.0%	0.0%	0.0%	0.0%	0.0%	0.0%	0.0%	0.0%	0.0%	0.0%	0.0%	0.0%	0.0%
Buses	7	0	0	7	0	0	0	0	0	0	0	0	0	9	0	9	0	0	16
% Buses	4.3%	0.0%	0.0%	0.0%	0.0%	0.0%	0.0%	0.0%	0.0%	0.0%	0.0%	0.0%	0.0%	7.5%	0.0%	0.0%	0.0%	0.0%	5.1%
Pedestrians	0	0	0	0	0	0	0	0	0	0	0	1	0	0	0	0	0	0	0
% Pedestrians	0.0%	0.0%	0.0%	0.0%	0.0%	0.0%	0.0%	0.0%	0.0%	0.0%	0.0%	100.0%	0.0%	0.0%	0.0%	0.0%	0.0%	0.0%	0.0%
Bicycles on Crosswalk	0	0	0	0	0	0	0	0	0	0	1	0	0	0	0	0	0	0	0
% Bicycles on Crosswalk	0.0%	0.0%	0.0%	0.0%	0.0%	0.0%	0.0%	0.0%	0.0%	0.0%	100.0%	0.0%	0.0%	0.0%	0.0%	0.0%	0.0%	0.0%	0.0%

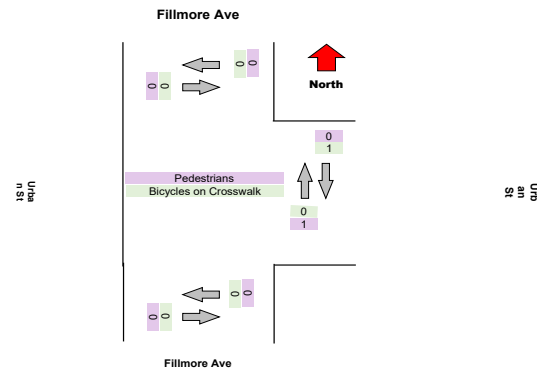
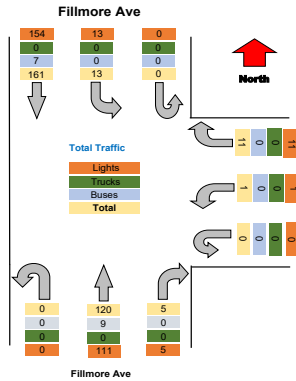

Turning Movement Peak Hour Data (PM)
 4:45:00 PM

Leg Direction	Fillmore Ave Southbound						Urban St Westbound						Fillmore Ave Northbound						Total
	Thru	Left	U-Turn	App Total	Peds CW	Peds CCW	Right	Left	U-Turn	App Total	Peds CW	Peds CCW	Right	Thru	U-Turn	App Total	Peds CW	Peds CCW	
4:45:00 PM	67	4	0	71	0	0	1	1	0	2	0	0	4	79	0	83	0	0	156
5:00:00 PM	70	10	0	80	2	2	2	2	0	4	0	0	0	79	0	79	0	0	163
5:15:00 PM	58	4	0	62	0	0	7	1	0	8	1	0	1	74	0	75	0	0	145
5:30:00 PM	63	3	0	66	0	0	4	3	0	7	1	0	3	65	0	68	0	0	141
Grand Total	258	21	0	279	2	2	14	7	0	21	2	0	8	297	0	305	0	0	605
% Approach	92.5%	7.5%	0.0%	0.0%	0.0%	0.0%	66.7%	33.3%	0.0%	0.0%	0.0%	0.0%	2.6%	97.4%	0.0%	0.0%	0.0%	0.0%	0.0%
% Total	42.6%	3.5%	0.0%	46.1%	0.0%	0.0%	2.3%	1.2%	0.0%	3.5%	0.0%	0.0%	1.3%	49.1%	0.0%	50.4%	0.0%	0.0%	0.0%
PHF	0.921	0.525	0.000	0.872	0.000	0.000	0.500	0.583	0.000	0.656	0.000	0.000	0.500	0.940	0.000	0.919	0.000	0.000	0.928
Lights	251	20	0	271	0	0	14	7	0	21	0	0	8	292	0	300	0	0	592
% Lights	97.3%	95.2%	0.0%	97.1%	0.0%	0.0%	100.0%	100.0%	0.0%	100.0%	0.0%	0.0%	100.0%	98.3%	0.0%	98.4%	0.0%	0.0%	97.9%
Trucks	1	0	0	1	0	0	0	0	0	0	0	0	0	2	0	2	0	0	3
% Trucks	0.4%	0.0%	0.0%	0.4%	0.0%	0.0%	0.0%	0.0%	0.0%	0.0%	0.0%	0.0%	0.0%	0.7%	0.0%	0.7%	0.0%	0.0%	0.5%
Buses	6	1	0	7	0	0	0	0	0	0	0	0	0	3	0	3	0	0	10
% Buses	2.3%	4.8%	0.0%	0.0%	0.0%	0.0%	0.0%	0.0%	0.0%	0.0%	0.0%	0.0%	0.0%	1.0%	0.0%	0.0%	0.0%	0.0%	1.7%
Pedestrians	0	0	0	0	2	2	0	0	0	2	0	0	0	0	0	0	0	0	0
% Pedestrians	0.0%	0.0%	0.0%	0.0%	100.0%	100.0%	0.0%	0.0%	0.0%	0.0%	100.0%	0.0%	0.0%	0.0%	0.0%	0.0%	0.0%	0.0%	0.0%
Bicycles on Crosswalk	0	0	0	0	0	0	0	0	0	0	0	0	0	0	0	0	0	0	0
% Bicycles on Crosswalk	0.0%	0.0%	0.0%	0.0%	0.0%	0.0%	0.0%	0.0%	0.0%	0.0%	0.0%	0.0%	0.0%	0.0%	0.0%	0.0%	0.0%	0.0%	0.0%

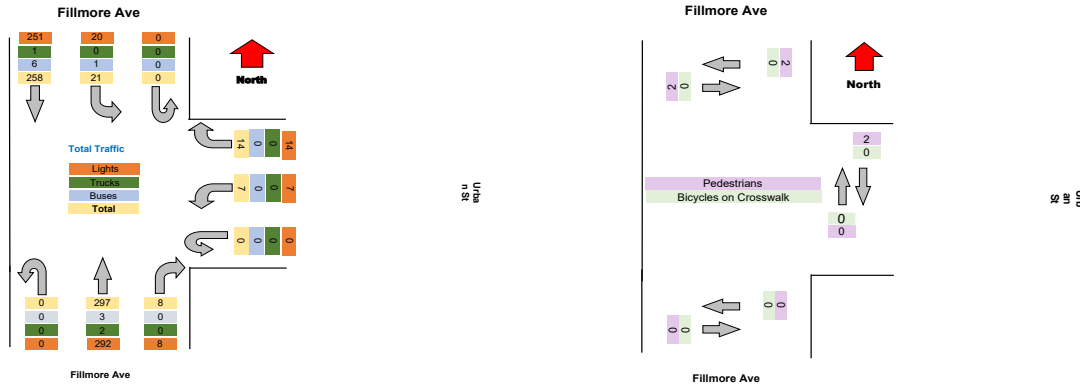

Intersection: Elm St Pine St
 Location: Kennett Square, PA
 Site: 01
 Survey Date: Wednesday, 04-28-2021
 GPS: 42.948550, -72.790034



Project	LaBella
Project Code	LaBella
Site Name	20
Legs and Movements	All Processed Legs & Movements
Bin Size	15 minutes
Survey Date	2021-11-03, Wednesday
Location	20
Latitude and Longitude	42.909422, -78.839056

	Start	End	PHF
Forced Peak AM	2021/11/03 07:30:00	2021/11/03 08:30:00	0.845
Forced Peak PM	2021/11/03 16:30:00	2021/11/03 17:30:00	0.873
AM Peak	2021/11/03 07:30:00	2021/11/03 08:30:00	0.845
PM Peak	2021/11/03 16:45:00	2021/11/03 17:45:00	0.838

Turning Movement Data

Leg Direction	Fillmore Ave Southbound					Urban St Westbound					Fillmore Ave Northbound					Total
	Thru	Left	U-Turn	App Total	Peds CW Peds CCW	Right	Left	U-Turn	App Total	Peds CW Peds CCW	Right	Thru	U-Turn	App Total	Peds CW Peds CCW	
6:30:00 AM	22	1	0	23	0	3	0	0	3	0	0	18	0	18	0	44
6:45:00 AM	30	1	0	31	0	3	2	0	5	0	0	32	0	33	0	69
Hourly Total	52	2	0	54	0	6	2	0	8	0	0	50	0	51	0	113
7:00:00 AM	34	3	0	37	0	1	0	0	1	4	0	0	26	30	1	68
7:15:00 AM	40	6	0	46	1	2	2	0	4	2	1	0	30	33	0	83
7:30:00 AM	52	9	0	61	0	1	2	0	3	7	3	4	37	51	0	115
7:45:00 AM	80	3	0	83	0	1	1	0	2	10	2	1	62	75	0	160
Hourly Total	206	21	0	227	1	5	5	0	10	23	6	5	155	189	1	426
8:00:00 AM	68	4	0	72	0	8	1	0	9	7	0	1	46	54	0	135
8:15:00 AM	63	5	0	68	0	2	1	0	3	7	0	0	53	60	0	131
Hourly Total	131	9	0	140	0	10	2	0	12	14	0	1	99	114	0	266
4:00:00 PM	66	6	0	72	0	4	2	0	6	4	1	3	80	83	0	161
4:15:00 PM	74	6	0	80	0	5	3	0	8	2	5	5	85	90	0	178
4:30:00 PM	91	8	0	99	0	7	1	0	8	1	2	1	66	67	0	174
4:45:00 PM	84	5	0	89	0	3	3	1	4	2	3	1	101	102	0	195
Hourly Total	315	25	0	340	0	19	7	0	26	9	11	10	332	342	0	708
5:00:00 PM	72	4	0	76	0	4	1	0	5	0	4	2	77	79	0	160
5:15:00 PM	70	4	0	74	0	5	3	0	8	1	1	5	65	70	0	152
5:30:00 PM	74	1	0	75	0	4	3	0	7	0	0	1	64	65	0	147
5:45:00 PM	64	4	0	68	1	6	2	0	8	4	1	1	73	74	1	150
Hourly Total	280	13	0	293	1	19	9	0	28	5	6	9	279	288	1	609
Grand Total	984	70	0	1054	2	59	25	0	84	51	23	26	915	984	2	2122
% Approach	93.4%	6.6%	0.0%	0.0%	0.0%	70.2%	29.8%	0.0%	0.0%	0.0%	0.0%	2.6%	93.0%	0.0%	0.0%	0.0%
% Total	46.4%	3.3%	0.0%	49.7%	0.0%	2.8%	1.2%	0.0%	4.0%	0.0%	0.0%	1.2%	43.1%	0.0%	46.4%	0.0%
Lights	916	66	0	982	0	55	22	0	77	0	0	26	854	0	880	0
% Lights	93.1%	94.3%	0.0%	93.2%	0.0%	93.2%	88.0%	0.0%	91.7%	0.0%	0.0%	100.0%	93.3%	0.0%	89.4%	0.0%
Trucks	2	0	0	2	0	0	0	0	0	0	0	0	2	0	2	0
% Trucks	0.2%	0.0%	0.0%	0.2%	0.0%	0.0%	0.0%	0.0%	0.0%	0.0%	0.0%	0.0%	0.2%	0.0%	0.2%	0.0%
Buses	66	4	0	70	0	4	3	0	7	0	0	0	59	0	59	0
% Buses	6.7%	5.7%	0.0%	0.0%	0.0%	0.0%	12.0%	0.0%	0.0%	0.0%	0.0%	0.0%	6.4%	0.0%	0.0%	0.0%
Pedestrians	0	0	0	0	2	8	0	0	0	48	20	0	0	0	2	2
% Pedestrians	0.0%	0.0%	0.0%	0.0%	100.0%	88.9%	0.0%	0.0%	0.0%	94.1%	87.0%	0.0%	0.0%	0.0%	0.0%	100.0%
Bicycles on Crosswalk	0	0	0	0	0	1	0	0	0	3	3	0	0	0	0	0
% Bicycles on Crosswalk	0.0%	0.0%	0.0%	0.0%	0.0%	11.1%	0.0%	0.0%	0.0%	5.9%	13.0%	0.0%	0.0%	0.0%	0.0%	0.0%

Turning Movement Data Plot

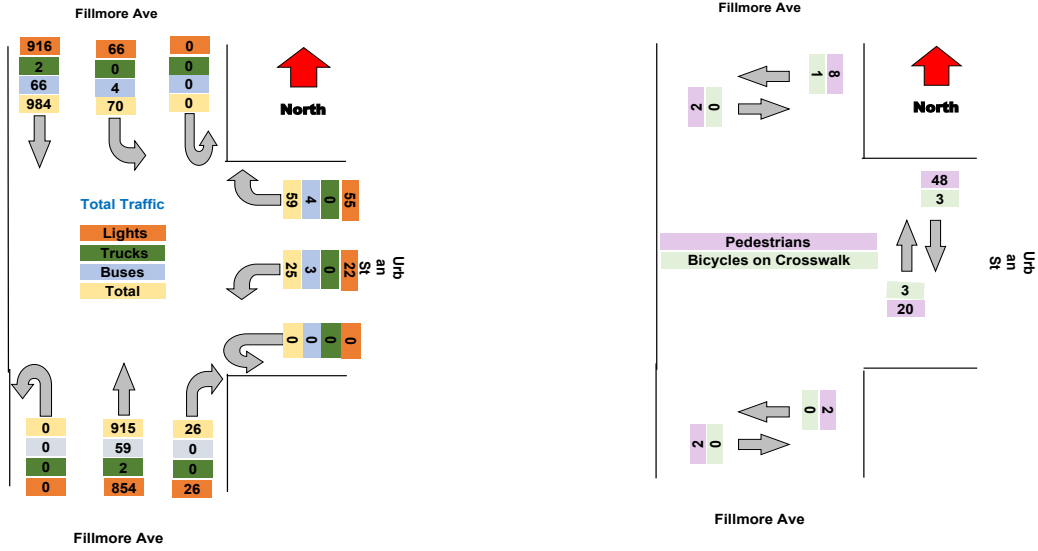

Turning Movement Peak Hour Data (AM)
 7:30:00 AM

Leg Direction	Fillmore Ave Southbound						Urban St Westbound						Fillmore Ave Northbound						Total
	Thru	Left	U-Turn	App Total	Peds CW	Peds CCW	Right	Left	U-Turn	App Total	Peds CW	Peds CCW	Right	Thru	U-Turn	App Total	Peds CW	Peds CCW	
7:30:00 AM	52	9	0	61	0	0	1	2	0	3	7	3	4	37	0	51	0	0	115
7:45:00 AM	80	3	0	83	0	0	1	1	0	3	10	2	1	62	0	75	0	0	160
8:00:00 AM	68	4	0	72	0	0	8	1	0	9	7	0	1	46	0	54	0	1	135
8:15:00 AM	63	5	0	68	0	0	2	1	0	3	7	0	0	53	0	60	0	0	131
Grand Total	263	21	0	284	0	0	12	5	0	17	31	5	6	198	0	240	0	1	541
% Approach	92.6%	7.4%	0.0%	0.0%	0.0%	0.0%	70.6%	29.4%	0.0%	0.0%	0.0%	0.0%	2.5%	82.5%	0.0%	0.0%	0.0%	0.0%	
% Total	48.6%	3.9%	0.0%	52.5%	0.0%	0.0%	2.2%	0.9%	0.0%	3.1%	0.0%	0.0%	1.1%	36.6%	0.0%	44.4%	0.0%	0.0%	
PHF	0.822	0.583	0.000	0.855	0.000	0.000	0.375	0.625	0.000	0.472	0.000	0.000	0.375	0.798	0.000	0.800	0.000	0.000	0.845
Lights	241	21	0	262	0	0	11	4	0	15	0	0	6	174	0	180	0	0	457
% Lights	91.6%	100.0%	0.0%	92.3%	0.0%	0.0%	91.7%	80.0%	0.0%	88.2%	0.0%	0.0%	100.0%	87.9%	0.0%	75.0%	0.0%	0.0%	84.5%
Trucks	0	0	0	0	0	0	0	0	0	0	0	0	0	0	0	0	0	0	0
% Trucks	0.0%	0.0%	0.0%	0.0%	0.0%	0.0%	0.0%	0.0%	0.0%	0.0%	0.0%	0.0%	0.0%	0.0%	0.0%	0.0%	0.0%	0.0%	0.0%
Buses	22	0	0	22	0	0	1	1	0	2	0	0	0	24	0	24	0	0	48
% Buses	8.4%	0.0%	0.0%	0.0%	0.0%	0.0%	8.3%	20.0%	0.0%	0.0%	0.0%	0.0%	0.0%	12.1%	0.0%	0.0%	0.0%	0.0%	8.9%
Pedestrians	0	0	0	0	0	0	0	0	0	0	30	5	0	0	0	0	0	1	0
% Pedestrians	0.0%	0.0%	0.0%	0.0%	0.0%	0.0%	0.0%	0.0%	0.0%	0.0%	96.8%	100.0%	0.0%	0.0%	0.0%	0.0%	0.0%	100.0%	0.0%
Bicycles on Crosswalk	0	0	0	0	0	0	0	0	0	0	1	0	0	0	0	0	0	0	0
% Bicycles on Crosswalk	0.0%	0.0%	0.0%	0.0%	0.0%	0.0%	0.0%	0.0%	0.0%	0.0%	3.2%	0.0%	0.0%	0.0%	0.0%	0.0%	0.0%	0.0%	0.0%

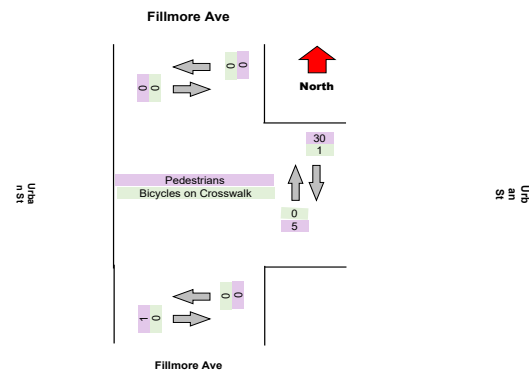
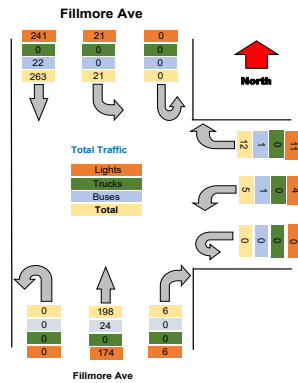

Turning Movement Peak Hour Data (PM)

4:45:00 PM

Leg Direction	Fillmore Ave Southbound						Urban St Westbound						Fillmore Ave Northbound						Total
	Thru	Left	U-Turn	App Total	Peds CW	Peds CCW	Right	Left	U-Turn	App Total	Peds CW	Peds CCW	Right	Thru	U-Turn	App Total	Peds CW	Peds CCW	
4:45:00 PM	84	5	0	89	0	3	3	1	0	4	2	3	1	101	0	102	0	0	195
5:00:00 PM	72	4	0	76	0	1	4	1	0	5	0	4	2	77	0	79	0	0	160
5:15:00 PM	70	4	0	74	0	0	5	3	0	8	1	1	5	65	0	70	0	0	152
5:30:00 PM	74	1	0	75	0	1	4	3	0	7	0	0	1	64	0	65	0	1	147
Grand Total	300	14	0	314	0	5	16	8	0	24	3	8	9	307	0	316	0	1	654
% Approach	95.5%	4.5%	0.0%	0.0%	0.0%	0.0%	66.7%	33.3%	0.0%	0.0%	0.0%	0.0%	2.8%	97.2%	0.0%	0.0%	0.0%	0.0%	
% Total	45.9%	2.1%	0.0%	48.0%	0.0%	0.0%	2.4%	1.2%	0.0%	3.7%	0.0%	0.0%	1.4%	46.9%	0.0%	48.3%	0.0%	0.0%	
PHF	0.893	0.700	0.000	0.882	0.000	0.000	0.800	0.667	0.000	0.750	0.000	0.000	0.450	0.760	0.000	0.775	0.000	0.000	0.838
Lights	292	14	0	306	0	0	15	8	0	23	0	0	9	297	0	306	0	0	635
% Lights	97.3%	100.0%	0.0%	97.5%	0.0%	0.0%	93.8%	###	0.0%	95.8%	0.0%	0.0%	100.0%	96.7%	0.0%	96.8%	0.0%	0.0%	97.1%
Trucks	0	0	0	0	0	0	0	0	0	0	0	0	0	1	0	1	0	0	1
% Trucks	0.0%	0.0%	0.0%	0.0%	0.0%	0.0%	0.0%	0.0%	0.0%	0.0%	0.0%	0.0%	0.0%	0.3%	0.0%	0.3%	0.0%	0.0%	0.2%
Buses	8	0	0	8	0	0	1	0	0	1	0	0	0	0	0	9	0	0	18
% Buses	2.7%	0.0%	0.0%	0.0%	0.0%	0.0%	6.3%	0.0%	0.0%	0.0%	0.0%	0.0%	0.0%	2.9%	0.0%	0.0%	0.0%	0.0%	2.8%
Pedestrians	0	0	0	0	0	4	0	0	0	3	6	0	0	0	0	0	0	1	0
% Pedestrians	0.0%	0.0%	0.0%	0.0%	0.0%	80.0%	0.0%	0.0%	0.0%	0.0%	100.0%	75.0%	0.0%	0.0%	0.0%	0.0%	0.0%	100.0%	0.0%
Bicycles on Crosswalk	0	0	0	0	0	1	0	0	0	0	2	0	0	0	0	0	0	0	0
% Bicycles on Crosswalk	0.0%	0.0%	0.0%	0.0%	0.0%	20.0%	0.0%	0.0%	0.0%	0.0%	25.0%	0.0%	0.0%	0.0%	0.0%	0.0%	0.0%	0.0%	0.0%



Urban St

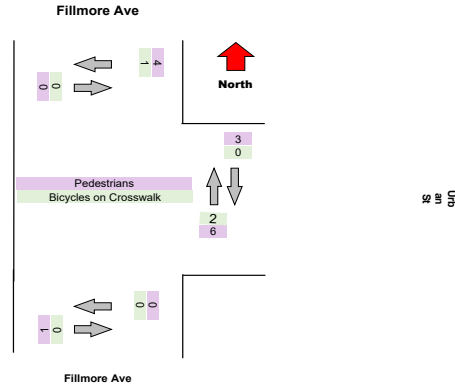

Turning Movement Data Plot

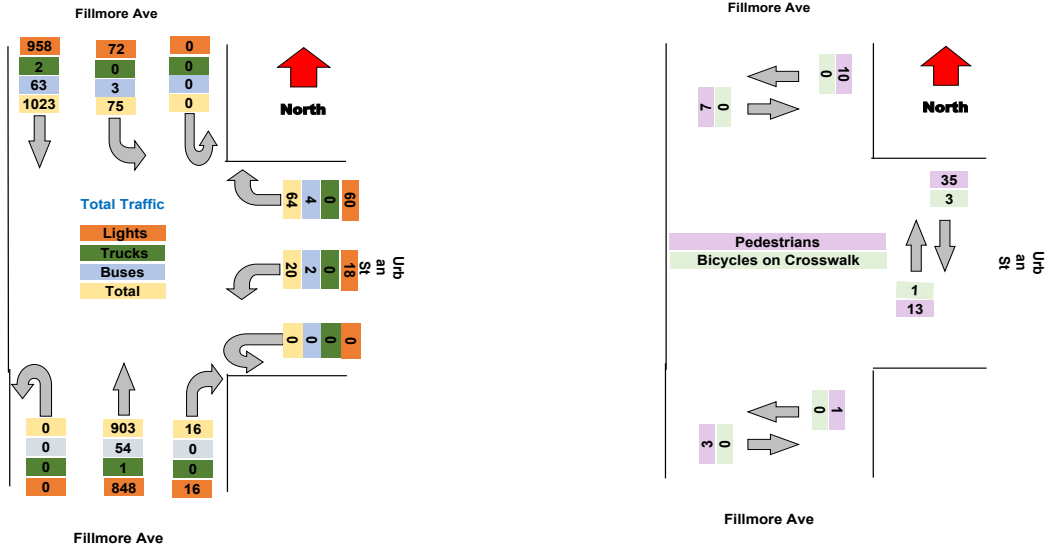

Turning Movement Peak Hour Data (AM)
 7:30:00 AM

Leg Direction	Fillmore Ave Southbound						Urban St Westbound						Fillmore Ave Northbound						Total
	Thru	Left	U-Turn	App Total	Peds CW	Peds CCW	Right	Left	U-Turn	App Total	Peds CW	Peds CCW	Right	Thru	U-Turn	App Total	Peds CW	Peds CCW	
7:30:00 AM	60	8	0	68	0	0	3	1	0	4	5	2	0	34	0	41	1	0	113
7:45:00 AM	71	4	0	75	1	0	2	0	0	2	12	2	0	46	0	60	0	0	137
8:00:00 AM	82	4	0	86	0	0	2	1	0	3	7	0	0	53	0	60	0	1	149
8:15:00 AM	73	4	0	77	0	0	2	0	0	2	2	0	3	51	0	56	0	2	135
Grand Total	286	20	0	306	1	0	9	2	0	11	26	4	3	184	0	217	1	3	534
% Approach	93.5%	6.5%	0.0%	0.0%	0.0%	0.0%	81.8%	18.2%	0.0%	0.0%	0.0%	0.0%	1.4%	84.8%	0.0%	0.0%	0.0%	0.0%	
% Total	53.6%	3.7%	0.0%	57.3%	0.0%	0.0%	1.7%	0.4%	0.0%	2.1%	0.0%	0.0%	0.6%	34.5%	0.0%	40.6%	0.0%	0.0%	
PHF	0.872	0.625	0.000	0.890	0.000	0.000	0.750	0.500	0.000	0.688	0.000	0.000	0.250	0.868	0.000	0.904	0.000	0.000	0.896
Lights	266	20	0	286	0	0	8	2	0	10	0	0	3	166	0	169	0	0	465
% Lights	93.0%	100.0%	0.0%	93.5%	0.0%	0.0%	88.9%	100.0%	0.0%	90.9%	0.0%	0.0%	100.0%	90.2%	0.0%	77.9%	0.0%	0.0%	87.1%
Trucks	0	0	0	0	0	0	0	0	0	0	0	0	0	0	0	0	0	0	0
% Trucks	0.0%	0.0%	0.0%	0.0%	0.0%	0.0%	0.0%	0.0%	0.0%	0.0%	0.0%	0.0%	0.0%	0.0%	0.0%	0.0%	0.0%	0.0%	0.0%
Buses	20	0	0	20	0	0	1	0	0	1	0	0	0	18	0	18	0	0	39
% Buses	7.0%	0.0%	0.0%	0.0%	0.0%	0.0%	11.1%	0.0%	0.0%	0.0%	0.0%	0.0%	0.0%	9.8%	0.0%	0.0%	0.0%	0.0%	7.3%
Pedestrians	0	0	0	0	1	0	0	0	0	0	25	4	0	0	0	0	1	3	0
% Pedestrians	0.0%	0.0%	0.0%	0.0%	100.0%	0.0%	0.0%	0.0%	0.0%	0.0%	96.2%	100.0%	0.0%	0.0%	0.0%	0.0%	100.0%	100.0%	0.0%
Bicycles on Crosswalk	0	0	0	0	0	0	0	0	0	0	1	0	0	0	0	0	0	0	0
% Bicycles on Crosswalk	0.0%	0.0%	0.0%	0.0%	0.0%	0.0%	0.0%	0.0%	0.0%	0.0%	3.8%	0.0%	0.0%	0.0%	0.0%	0.0%	0.0%	0.0%	0.0%

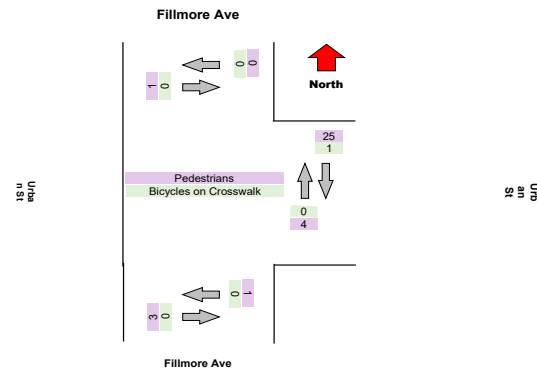
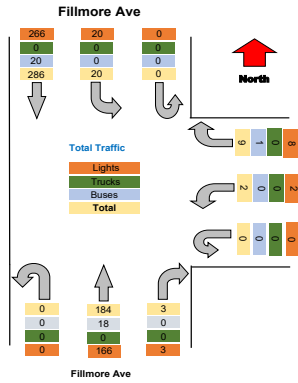

Turning Movement Peak Hour Data (PM)
 4:45:00 PM

Leg Direction	Fillmore Ave Southbound						Urban St Westbound						Fillmore Ave Northbound						Total
	Thru	Left	U-Turn	App Total	Peds CW	Peds CCW	Right	Left	U-Turn	App Total	Peds CW	Peds CCW	Right	Thru	U-Turn	App Total	Peds CW	Peds CCW	
4:45:00 PM	90	4	0	94	0	4	8	3	0	11	0	4	2	94	0	96	0	0	201
5:00:00 PM	71	4	0	75	1	1	7	3	0	10	2	0	1	91	0	92	0	0	177
5:15:00 PM	80	3	0	83	1	1	5	1	0	6	0	0	1	79	0	80	0	0	169
5:30:00 PM	73	5	0	78	0	1	4	1	0	5	2	0	0	65	0	65	0	0	148
Grand Total	314	16	0	330	2	7	24	8	0	32	4	4	4	329	0	333	0	0	695
% Approach	95.2%	4.8%	0.0%	0.0%	0.0%	0.0%	75.0%	25.0%	0.0%	0.0%	0.0%	0.0%	1.2%	98.8%	0.0%	0.0%	0.0%	0.0%	0.0%
% Total	45.2%	2.3%	0.0%	47.5%	0.0%	0.0%	3.5%	1.2%	0.0%	4.6%	0.0%	0.0%	0.6%	47.3%	0.0%	47.9%	0.0%	0.0%	0.0%
PHF	0.872	0.800	0.000	0.878	0.000	0.000	0.750	0.667	0.000	0.727	0.000	0.000	0.500	0.875	0.000	0.867	0.000	0.000	0.864
Lights	302	16	0	318	0	0	24	8	0	32	0	0	4	320	0	324	0	0	674
% Lights	96.2%	100.0%	0.0%	96.4%	0.0%	0.0%	100.0%	100.0%	0.0%	100.0%	0.0%	0.0%	100.0%	97.3%	0.0%	97.3%	0.0%	0.0%	97.0%
Trucks	2	0	0	2	0	0	0	0	0	0	0	0	0	1	0	1	0	0	3
% Trucks	0.6%	0.0%	0.0%	0.6%	0.0%	0.0%	0.0%	0.0%	0.0%	0.0%	0.0%	0.0%	0.0%	0.3%	0.0%	0.3%	0.0%	0.0%	0.4%
Buses	10	0	0	10	0	0	0	0	0	0	0	0	0	8	0	8	0	0	18
% Buses	3.2%	0.0%	0.0%	0.0%	0.0%	0.0%	0.0%	0.0%	0.0%	0.0%	0.0%	0.0%	0.0%	2.4%	0.0%	0.0%	0.0%	0.0%	2.6%
Pedestrians	0	0	0	0	2	7	0	0	0	2	4	0	0	0	0	0	0	0	0
% Pedestrians	0.0%	0.0%	0.0%	0.0%	100.0%	100.0%	0.0%	0.0%	0.0%	0.0%	50.0%	100.0%	0.0%	0.0%	0.0%	0.0%	0.0%	0.0%	0.0%
Bicycles on Crosswalk	0	0	0	0	0	0	0	0	0	2	0	0	0	0	0	0	0	0	0
% Bicycles on Crosswalk	0.0%	0.0%	0.0%	0.0%	0.0%	0.0%	0.0%	0.0%	0.0%	0.0%	50.0%	0.0%	0.0%	0.0%	0.0%	0.0%	0.0%	0.0%	0.0%

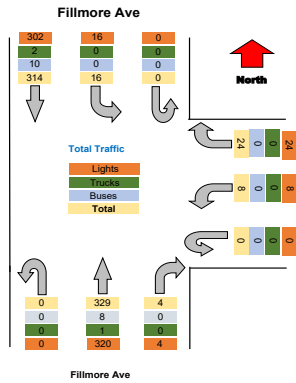

Urban St

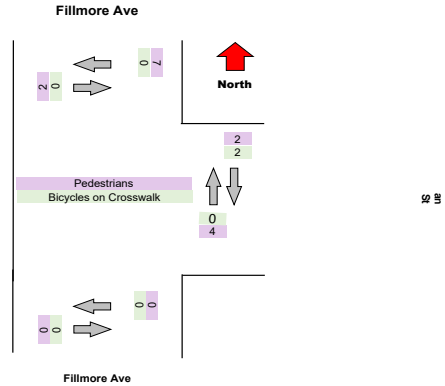

Urban St

Project	LaBella
Project Code	LaBella
Site Name	21
Legs and Movements	All Processed Legs & Movements
Bin Size	15 minutes
Survey Date	2021-11-02, Tuesday
Location	21
Latitude and Longitude	42.909289, -78.839090

	Start	End	PHF
Forced Peak AM	2021/11/02 07:30:00	2021/11/02 08:30:00	0.892
Forced Peak PM	2021/11/02 16:30:00	2021/11/02 17:30:00	0.925
AM Peak	2021/11/02 07:30:00	2021/11/02 08:30:00	0.892
PM Peak	2021/11/02 16:45:00	2021/11/02 17:45:00	0.939

Turning Movement Data

Leg Direction	Fillmore Ave Southbound						Fillmore Ave Northbound						Riley St Eastbound					
	Right	Thru	U-Turn	App Total	Peds CW	Peds CCW	Thru	Left	U-Turn	App Total	Peds CW	Peds CCW	Right	Left	U-Turn	App Total	Peds CW	
Start Time																		
6:30:00 AM	1	21	0	22	0	0	17	0	0	17	0	0	0	0	0	0	0	0
6:45:00 AM	1	26	0	27	0	0	25	0	0	25	0	0	1	0	0	1	0	0
Hourly Total	2	47	0	49	0	0	42	0	0	42	0	0	1	0	0	1	0	0
7:00:00 AM	1	22	0	23	0	0	25	1	0	26	0	0	0	1	0	1	0	0
7:15:00 AM	2	24	0	26	0	0	32	0	0	32	0	0	0	0	0	0	0	0
7:30:00 AM	0	27	0	27	0	0	27	0	0	27	0	0	0	2	0	2	1	0
7:45:00 AM	0	43	0	43	0	0	37	0	0	37	0	0	0	1	0	1	0	0
Hourly Total	3	116	0	119	0	0	121	1	0	122	0	0	0	4	0	4	1	0
8:00:00 AM	1	46	0	47	0	0	29	0	0	29	0	0	0	0	0	0	0	0
8:15:00 AM	1	45	0	46	0	0	28	1	0	29	0	0	0	1	0	1	0	0
Hourly Total	2	91	0	93	0	0	57	1	0	58	0	0	0	1	0	1	0	0
4:00:00 PM	4	84	0	88	0	0	70	1	0	71	1	0	2	0	0	2	1	0
4:15:00 PM	1	72	0	73	0	0	72	2	0	74	0	0	0	2	0	2	1	0
4:30:00 PM	0	62	0	62	0	0	68	2	0	70	0	0	0	0	0	0	0	0
4:45:00 PM	3	65	0	68	0	0	81	1	0	82	0	0	2	2	0	4	2	0
Hourly Total	8	283	0	291	0	0	291	6	0	297	1	0	4	4	0	8	6	0
5:00:00 PM	3	69	0	72	0	0	78	1	0	79	0	0	4	1	0	5	3	0
5:15:00 PM	1	56	0	57	0	0	75	1	0	76	0	0	2	0	0	2	2	0
5:30:00 PM	1	69	0	70	0	0	66	2	0	68	0	0	1	2	0	3	0	0
5:45:00 PM	5	56	0	61	0	0	53	2	0	55	0	0	1	0	0	1	1	0
Hourly Total	10	250	0	260	0	0	272	6	0	278	0	0	8	3	0	11	6	0
Grand Total	25	787	0	812	0	0	783	14	0	797	1	0	13	12	0	25	14	0
% Approach	3.1%	96.9%	0.0%	0.0%	0.0%	0.0%	98.2%	1.8%	0.0%	0.0%	0.0%	0.0%	52.0%	48.0%	0.0%	0.0%	0.0%	0.0%
% Total	1.5%	48.2%	0.0%	49.7%	0.0%	0.0%	47.9%	0.9%	0.0%	48.8%	0.0%	0.0%	0.8%	0.7%	0.0%	1.5%	0.0%	0.0%
Lights	24	760	0	784	0	0	761	14	0	775	0	0	13	11	0	24	0	0
% Lights	96.0%	96.6%	0.0%	96.6%	0.0%	0.0%	97.2%	100.0%	0.0%	97.2%	0.0%	0.0%	100.0%	91.7%	0.0%	96.0%	0.0%	0.0%
Trucks	0	2	0	2	0	0	2	0	0	2	0	0	0	0	0	0	0	0
% Trucks	0.0%	0.3%	0.0%	0.2%	0.0%	0.0%	0.3%	0.0%	0.0%	0.3%	0.0%	0.0%	0.0%	0.0%	0.0%	0.0%	0.0%	0.0%
Buses	1	24	0	25	0	0	20	0	0	20	0	0	0	1	0	1	0	0
% Buses	4.0%	3.0%	0.0%	0.0%	0.0%	0.0%	0.0%	0.0%	0.0%	0.0%	0.0%	0.0%	0.0%	8.3%	0.0%	0.0%	0.0%	0.0%
Pedestrians	0	0	0	0	0	0	0	0	0	0	1	0	0	0	0	0	13	0
% Pedestrians	0.0%	0.0%	0.0%	0.0%	0.0%	0.0%	0.0%	0.0%	0.0%	0.0%	100.0%	0.0%	0.0%	0.0%	0.0%	0.0%	92.9%	0.0%
Bicycles on Crosswalk	0	0	0	0	0	0	0	0	0	0	0	0	0	0	0	0	1	0
% Bicycles on Crosswalk	0.0%	0.0%	0.0%	0.0%	0.0%	0.0%	0.0%	0.0%	0.0%	0.0%	0.0%	0.0%	0.0%	0.0%	0.0%	0.0%	7.1%	0.0%

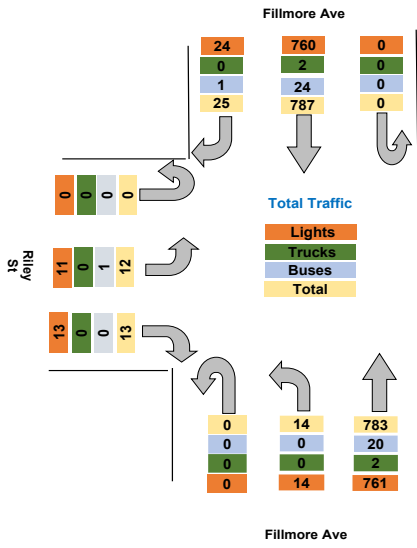

Turning Movement Data Plot

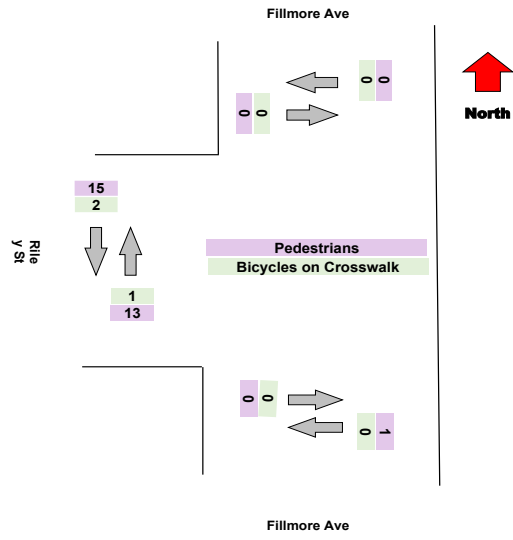

Turning Movement Peak Hour Data (AM)

7:30:00 AM

Leg Direction	Fillmore Ave Southbound						Fillmore Ave NorthBound						Riley St Eastbound				
	Right	Thru	U-Turn	App Total	Peds CW	Peds CCW	Thru	Left	U-Turn	App Total	Peds CW	Peds CCW	Right	Left	U-Turn	App Total	Peds CW
7:30:00 AM	0	27	0	27	0	0	27	0	0	27	0	0	0	2	0	2	1
7:45:00 AM	0	43	0	43	0	0	37	0	0	37	0	0	0	1	0	1	0
8:00:00 AM	1	46	0	47	0	0	29	0	0	29	0	0	0	0	0	0	0
8:15:00 AM	1	45	0	46	0	0	28	1	0	29	0	0	0	1	0	1	0
Grand Total	2	161	0	163	0	0	121	1	0	122	0	0	0	4	0	4	1
% Approach	1.2%	98.8%	0.0%	0.0%	0.0%	0.0%	99.2%	0.8%	0.0%	0.0%	0.0%	0.0%	0.0%	100.0%	0.0%	0.0%	0.0%
% Total	0.7%	55.7%	0.0%	56.4%	0.0%	0.0%	41.9%	0.3%	0.0%	42.2%	0.0%	0.0%	0.0%	1.4%	0.0%	1.4%	0.0%
PHF	0.500	0.875	0.000	0.867	0.000	0.000	0.818	0.250	0.000	0.824	0.000	0.000	0.000	0.500	0.000	0.500	0.000
Lights	2	154	0	156	0	0	112	1	0	113	0	0	0	4	0	4	0
% Lights	100.0%	95.7%	0.0%	95.7%	0.0%	0.0%	92.6%	100.0%	0.0%	92.6%	0.0%	0.0%	0.0%	100.0%	0.0%	100.0%	0.0%
Trucks	0	0	0	0	0	0	0	0	0	0	0	0	0	0	0	0	0
% Trucks	0.0%	0.0%	0.0%	0.0%	0.0%	0.0%	0.0%	0.0%	0.0%	0.0%	0.0%	0.0%	0.0%	0.0%	0.0%	0.0%	0.0%
Buses	0	7	0	7	0	0	9	0	0	9	0	0	0	0	0	0	0
% Buses	0.0%	4.3%	0.0%	0.0%	0.0%	0.0%	7.4%	0.0%	0.0%	0.0%	0.0%	0.0%	0.0%	0.0%	0.0%	0.0%	0.0%
Pedestrians	0	0	0	0	0	0	0	0	0	0	0	0	0	0	0	0	1
% Pedestrians	0.0%	0.0%	0.0%	0.0%	0.0%	0.0%	0.0%	0.0%	0.0%	0.0%	0.0%	0.0%	0.0%	0.0%	0.0%	0.0%	100.0%
Bicycles on Crosswalk	0	0	0	0	0	0	0	0	0	0	0	0	0	0	0	0	0
% Bicycles on Crosswalk	0.0%	0.0%	0.0%	0.0%	0.0%	0.0%	0.0%	0.0%	0.0%	0.0%	0.0%	0.0%	0.0%	0.0%	0.0%	0.0%	0.0%

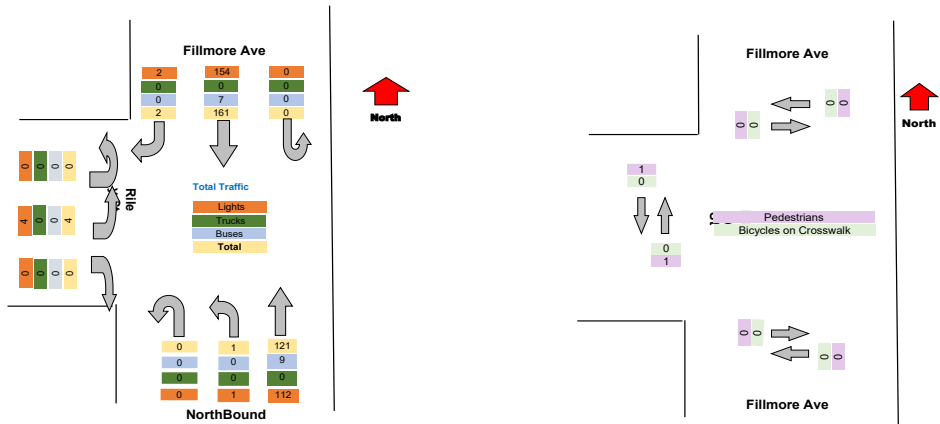

Turning Movement Peak Hour Data (PM)

4:45:00 PM

Leg Direction	Fillmore Ave Southbound						Fillmore Ave NorthBound						Riley St Eastbound				
	Right	Thru	U-Turn	App Total	Peds CW	Peds CCW	Thru	Left	U-Turn	App Total	Peds CW	Peds CCW	Right	Left	U-Turn	App Total	Peds CW
4:45:00 PM	3	65	0	68	0	0	81	1	0	82	0	0	2	2	0	4	2
5:00:00 PM	3	69	0	72	0	0	78	1	0	79	0	0	4	1	0	5	3
5:15:00 PM	1	56	0	57	0	0	75	1	0	76	0	0	2	0	0	2	2
5:30:00 PM	1	69	0	70	0	0	66	2	0	68	0	0	1	2	0	3	0
Grand Total	8	259	0	267	0	0	300	5	0	305	0	0	9	5	0	14	7
% Approach	3.0%	97.0%	0.0%	0.0%	0.0%	0.0%	98.4%	1.6%	0.0%	0.0%	0.0%	0.0%	64.3%	35.7%	0.0%	0.0%	0.0%
% Total	1.4%	44.2%	0.0%	45.6%	0.0%	0.0%	51.2%	0.9%	0.0%	52.0%	0.0%	0.0%	1.5%	0.9%	0.0%	2.4%	0.0%
PHF	0.667	0.938	0.000	0.927	0.000	0.000	0.926	0.625	0.000	0.930	0.000	0.000	0.563	0.625	0.000	0.700	0.000
Lights	8	252	0	260	0	0	295	5	0	300	0	0	9	5	0	14	0
% Lights	100.0%	97.3%	0.0%	97.4%	0.0%	0.0%	98.3%	100.0%	0.0%	98.4%	0.0%	0.0%	100.0%	100.0%	0.0%	100.0%	0.0%
Trucks	0	1	0	1	0	0	2	0	0	2	0	0	0	0	0	0	0
% Trucks	0.0%	0.4%	0.0%	0.4%	0.0%	0.0%	0.7%	0.0%	0.0%	0.7%	0.0%	0.0%	0.0%	0.0%	0.0%	0.0%	0.0%
Buses	0	6	0	6	0	0	3	0	0	3	0	0	0	0	0	0	0
% Buses	0.0%	2.3%	0.0%	0.0%	0.0%	0.0%	1.0%	0.0%	0.0%	0.0%	0.0%	0.0%	0.0%	0.0%	0.0%	0.0%	0.0%
Pedestrians	0	0	0	0	0	0	0	0	0	0	0	0	0	0	0	0	6
% Pedestrians	0.0%	0.0%	0.0%	0.0%	0.0%	0.0%	0.0%	0.0%	0.0%	0.0%	0.0%	0.0%	0.0%	0.0%	0.0%	0.0%	85.7%
Bicycles on Crosswalk	0	0	0	0	0	0	0	0	0	0	0	0	0	0	0	0	1
% Bicycles on Crosswalk	0.0%	0.0%	0.0%	0.0%	0.0%	0.0%	0.0%	0.0%	0.0%	0.0%	0.0%	0.0%	0.0%	0.0%	0.0%	0.0%	14.3%

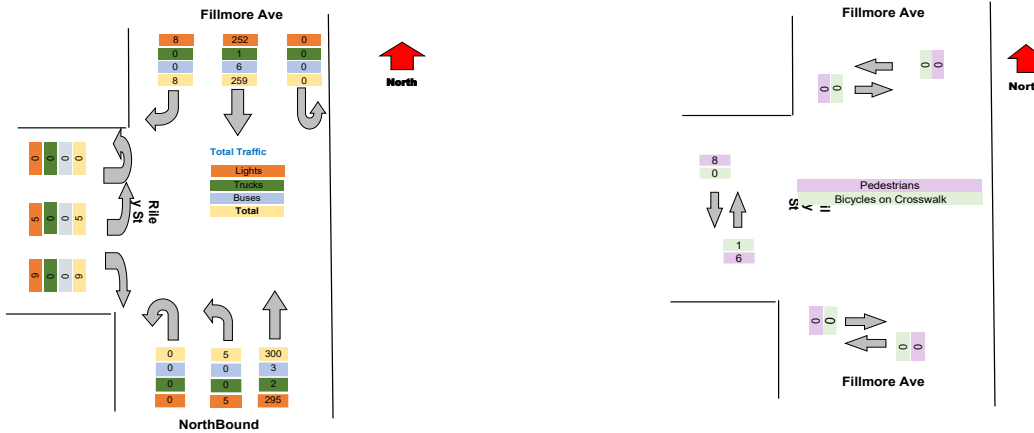

Intersection: Elm St Pine St
 Location: Kennett Square, PA
 Site: 01
 Survey Date: Wednesday, 04-28-2021
 GPS: 42.948550, -72.790034



Peds CCW	Total
1	39
1	53
2	92
0	50
0	58
0	56
0	81
0	245
1	76
0	76
1	152
0	161
2	149
1	132
4	154
7	596
0	156
4	135
0	141
3	117
7	549
17	1634
0.0%	0.0%
0.0%	0.0%
0	1583
0.0%	96.9%
0	4
0.0%	0.2%
0	46
0.0%	2.8%
15	0
88.2%	0.0%
2	0
11.8%	0.0%

Intersection: Elm St Pine St
 Location: Kennett Square, PA
 Site: 01
 Survey Date: Wednesday, 04-28-2021
 GPS: 42.948550, -72.790034



Peds CCW	Total
0	56
0	81
1	76
0	76
1	289
0.0%	
0.0%	
0.000	0.892
0	273
0.0%	94.5%
0	0
0.0%	0.0%
0	16
0.0%	5.5%
1	0
100.0%	0.0%
0	0
0.0%	0.0%

Intersection: Elm St Pine St
 Location: Kennett Square, PA
 Site: 01
 Survey Date: Wednesday, 04-28-2021
 GPS: 42.948550, -72.790034



Peds CCW	Total
4	154
0	156
4	135
0	141
8	586
0.0%	
0.0%	
0.000	0.939
0	574
0.0%	98.0%
0	3
0.0%	0.5%
0	9
0.0%	1.5%
8	0
100.0%	0.0%
0	0
0.0%	0.0%

Project	LaBella
Project Code	LaBella
Site Name	21
Legs and Movements	All Processed Legs & Movements
Bin Size	15 minutes
Survey Date	2021-11-03, Wednesday
Location	21
Latitude and Longitude	42.909289, -78.839090

	Start	End	PHF
Forced Peak AM	2021/11/03 07:30:00	2021/11/03 08:30:00	0.818
Forced Peak PM	2021/11/03 16:30:00	2021/11/03 17:30:00	0.861
AM Peak	2021/11/03 07:30:00	2021/11/03 08:30:00	0.818
PM Peak	2021/11/03 16:45:00	2021/11/03 17:45:00	0.833

Turning Movement Data

Leg Direction	Fillmore Ave Southbound					Fillmore Ave Northbound					Riley St Eastbound				
	Right	Thru	U-Turn	App Total	Peds CW Peds CCW	Thru	Left	U-Turn	App Total	Peds CW Peds CCW	Right	Left	U-Turn	App Total	Peds CW
Start Time															
6:30:00 AM	1	21	0	22	0 0	18	0	0	18	0 0	1	0	0	1	0
6:45:00 AM	3	29	0	32	0 0	33	0	0	33	0 0	0	0	0	0	0
Hourly Total	4	50	0	54	0 0	51	0	0	51	0 0	1	0	0	1	0
7:00:00 AM	0	34	0	34	0 0	26	0	0	26	0 0	0	0	0	0	0
7:15:00 AM	1	41	0	42	0 0	30	0	0	30	0 0	0	0	0	0	0
7:30:00 AM	1	52	0	53	0 0	37	2	0	39	0 0	0	4	0	4	0
7:45:00 AM	1	81	0	82	0 0	62	1	0	63	0 0	1	1	0	2	0
Hourly Total	3	208	0	211	0 0	155	3	0	158	0 0	1	5	0	6	1
8:00:00 AM	1	68	0	69	0 0	47	1	0	48	0 0	2	0	0	2	0
8:15:00 AM	0	64	0	64	0 0	53	1	0	54	0 0	1	0	0	1	1
Hourly Total	1	132	0	133	0 0	100	2	0	102	0 0	3	0	0	3	1
4:00:00 PM	1	67	0	68	0 0	81	0	0	81	1 1	1	3	0	4	3
4:15:00 PM	4	73	0	77	0 0	88	0	0	88	0 0	0	1	0	1	1
4:30:00 PM	4	87	0	91	0 0	67	3	0	70	0 0	2	0	0	2	0
4:45:00 PM	2	84	0	86	0 1	101	0	0	101	0 0	1	1	0	2	4
Hourly Total	11	311	0	322	0 1	337	3	0	340	1 1	4	5	0	9	8
5:00:00 PM	1	72	0	73	0 0	77	1	0	78	0 0	0	2	0	2	1
5:15:00 PM	3	70	0	73	0 0	68	2	0	70	0 0	1	2	0	3	5
5:30:00 PM	3	74	0	77	1 0	64	1	0	65	0 0	0	0	0	0	4
5:45:00 PM	2	64	0	66	0 1	74	3	0	77	3 0	2	1	0	3	5
Hourly Total	9	280	0	289	1 1	283	7	0	290	3 0	3	5	0	8	15
Grand Total	28	981	0	1009	1 2	926	15	0	941	4 1	12	15	0	27	25
% Approach	2.8%	97.2%	0.0%	0.0%	0.0%	98.4%	1.6%	0.0%	0.0%	0.0%	44.4%	55.6%	0.0%	0.0%	0.0%
% Total	1.4%	49.6%	0.0%	51.0%	0.0%	46.8%	0.8%	0.0%	47.6%	0.0%	0.6%	0.8%	0.0%	1.4%	0.0%
Lights	24	914	0	938	0 0	867	13	0	880	0 0	10	13	0	23	0
% Lights	85.7%	93.2%	0.0%	93.0%	0.0%	93.6%	86.7%	0.0%	93.5%	0.0%	83.3%	86.7%	0.0%	85.2%	0.0%
Trucks	0	2	0	2	0 0	2	0	0	2	0 0	0	0	0	0	0
% Trucks	0.0%	0.2%	0.0%	0.2%	0.0%	0.2%	0.0%	0.0%	0.2%	0.0%	0.0%	0.0%	0.0%	0.0%	0.0%
Buses	4	65	0	69	0 0	57	2	0	59	0 0	2	2	0	4	0
% Buses	14.3%	6.6%	0.0%	0.0%	0.0%	0.0%	13.3%	0.0%	0.0%	0.0%	16.7%	13.3%	0.0%	0.0%	0.0%
Pedestrians	0	0	0	0	1 2	0	0	0	0	3 0	0	0	0	0	23
% Pedestrians	0.0%	0.0%	0.0%	0.0%	100.0%	0.0%	0.0%	0.0%	0.0%	75.0%	0.0%	0.0%	0.0%	0.0%	92.0%
Bicycles on Crosswalk	0	0	0	0	0 0	0	0	0	0	1 1	0	0	0	0	2
% Bicycles on Crosswalk	0.0%	0.0%	0.0%	0.0%	0.0%	0.0%	0.0%	0.0%	0.0%	25.0%	100.0%	0.0%	0.0%	0.0%	8.0%

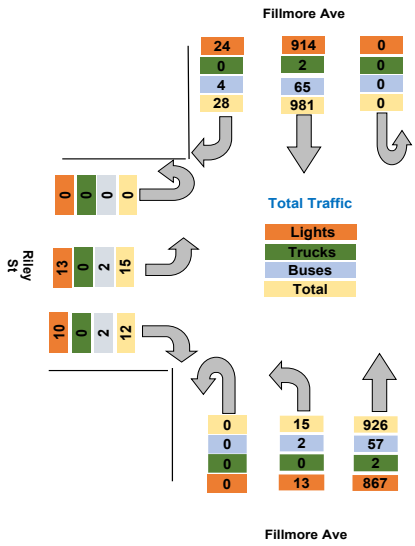

Turning Movement Data Plot

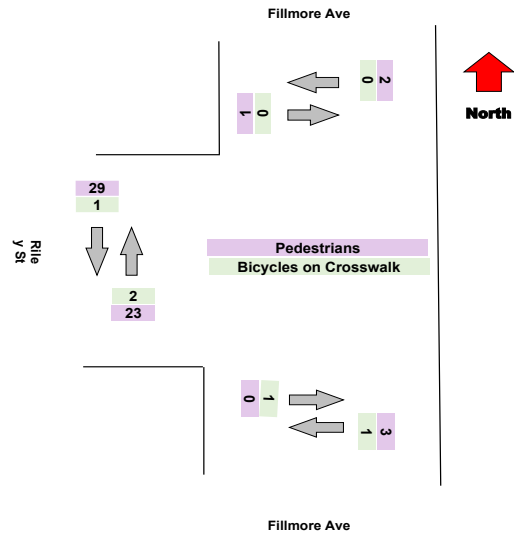

Turning Movement Peak Hour Data (AM)

7:30:00 AM

Leg Direction	Fillmore Ave Southbound						Fillmore Ave NorthBound						Riley St Eastbound				
	Right	Thru	U-Turn	App Total	Peds CW	Peds CCW	Thru	Left	U-Turn	App Total	Peds CW	Peds CCW	Right	Left	U-Turn	App Total	Peds CW
7:30:00 AM	1	52	0	53	0	0	37	2	0	39	0	0	0	4	0	4	0
7:45:00 AM	1	81	0	82	0	0	62	1	0	63	0	0	1	1	0	2	0
8:00:00 AM	1	68	0	69	0	0	47	1	0	48	0	0	2	0	0	2	0
8:15:00 AM	0	64	0	64	0	0	53	1	0	54	0	0	1	0	0	1	1
Grand Total	3	265	0	268	0	0	199	5	0	204	0	0	4	5	0	9	1
% Approach	1.1%	98.9%	0.0%	0.0%	0.0%	0.0%	97.5%	2.5%	0.0%	0.0%	0.0%	0.0%	44.4%	55.6%	0.0%	0.0%	0.0%
% Total	0.6%	55.1%	0.0%	55.7%	0.0%	0.0%	41.4%	1.0%	0.0%	42.4%	0.0%	0.0%	0.8%	1.0%	0.0%	1.9%	0.0%
PHF	0.750	0.818	0.000	0.817	0.000	0.000	0.802	0.625	0.000	0.810	0.000	0.000	0.500	0.313	0.000	0.563	0.000
Lights	3	242	0	245	0	0	176	4	0	180	0	0	3	4	0	7	0
% Lights	100.0%	91.3%	0.0%	91.4%	0.0%	0.0%	88.4%	80.0%	0.0%	88.2%	0.0%	0.0%	75.0%	80.0%	0.0%	77.8%	0.0%
Trucks	0	0	0	0	0	0	0	0	0	0	0	0	0	0	0	0	0
% Trucks	0.0%	0.0%	0.0%	0.0%	0.0%	0.0%	0.0%	0.0%	0.0%	0.0%	0.0%	0.0%	0.0%	0.0%	0.0%	0.0%	0.0%
Buses	0	23	0	23	0	0	23	1	0	24	0	0	1	1	0	2	0
% Buses	0.0%	8.7%	0.0%	0.0%	0.0%	0.0%	11.6%	20.0%	0.0%	0.0%	0.0%	0.0%	25.0%	20.0%	0.0%	0.0%	0.0%
Pedestrians	0	0	0	0	0	0	0	0	0	0	0	0	0	0	0	0	1
% Pedestrians	0.0%	0.0%	0.0%	0.0%	0.0%	0.0%	0.0%	0.0%	0.0%	0.0%	0.0%	0.0%	0.0%	0.0%	0.0%	0.0%	100.0%
Bicycles on Crosswalk	0	0	0	0	0	0	0	0	0	0	0	0	0	0	0	0	0
% Bicycles on Crosswalk	0.0%	0.0%	0.0%	0.0%	0.0%	0.0%	0.0%	0.0%	0.0%	0.0%	0.0%	0.0%	0.0%	0.0%	0.0%	0.0%	0.0%

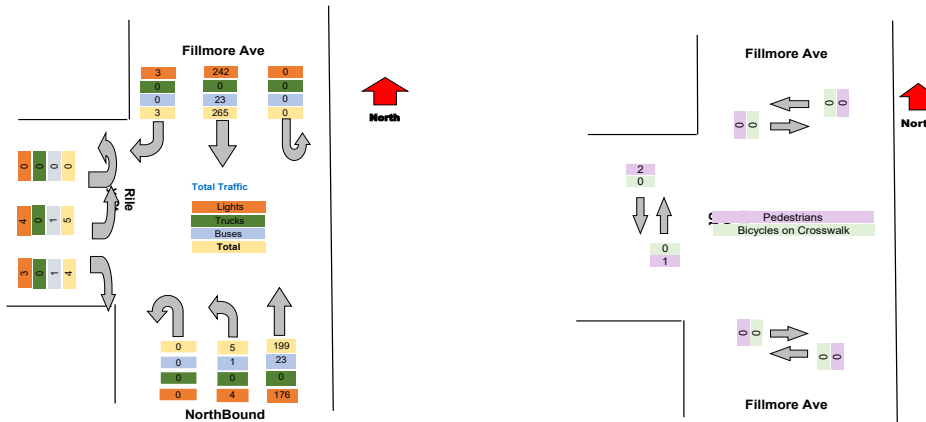

Turning Movement Peak Hour Data (PM)

4:45:00 PM

Leg Direction	Fillmore Ave Southbound						Fillmore Ave NorthBound						Riley St Eastbound				
	Right	Thru	U-Turn	App Total	Peds CW	Peds CCW	Thru	Left	U-Turn	App Total	Peds CW	Peds CCW	Right	Left	U-Turn	App Total	Peds CW
4:45:00 PM	2	84	0	86	0	1	101	0	0	101	0	0	1	1	0	2	4
5:00:00 PM	1	72	0	73	0	0	77	1	0	78	0	0	0	2	0	2	1
5:15:00 PM	3	70	0	73	0	0	68	2	0	70	0	0	1	2	0	3	5
5:30:00 PM	3	74	0	77	1	0	64	1	0	65	0	0	0	0	0	0	4
Grand Total	9	300	0	309	1	1	310	4	0	314	0	0	2	5	0	7	14
% Approach	2.9%	97.1%	0.0%	0.0%	0.0%	0.0%	98.7%	1.3%	0.0%	0.0%	0.0%	0.0%	28.6%	71.4%	0.0%	0.0%	0.0%
% Total	1.4%	47.6%	0.0%	49.0%	0.0%	0.0%	49.2%	0.6%	0.0%	49.8%	0.0%	0.0%	0.3%	0.8%	0.0%	1.1%	0.0%
PHF	0.750	0.893	0.000	0.898	0.000	0.000	0.767	0.500	0.000	0.777	0.000	0.000	0.500	0.625	0.000	0.583	0.000
Lights	8	292	0	300	0	0	301	3	0	304	0	0	2	5	0	7	0
% Lights	88.9%	97.3%	0.0%	97.1%	0.0%	0.0%	97.1%	75.0%	0.0%	96.8%	0.0%	0.0%	100.0%	100.0%	0.0%	100.0%	0.0%
Trucks	0	0	0	0	0	0	1	0	0	1	0	0	0	0	0	0	0
% Trucks	0.0%	0.0%	0.0%	0.0%	0.0%	0.0%	0.3%	0.0%	0.0%	0.3%	0.0%	0.0%	0.0%	0.0%	0.0%	0.0%	0.0%
Buses	1	8	0	9	0	0	2	1	0	3	0	0	0	0	0	0	0
% Buses	11.1%	2.7%	0.0%	0.0%	0.0%	0.0%	2.6%	25.0%	0.0%	0.0%	0.0%	0.0%	0.0%	0.0%	0.0%	0.0%	0.0%
Pedestrians	0	0	0	0	1	1	0	0	0	0	0	0	0	0	0	0	13
% Pedestrians	0.0%	0.0%	0.0%	0.0%	100.0%	100.0%	0.0%	0.0%	0.0%	0.0%	0.0%	0.0%	0.0%	0.0%	0.0%	0.0%	92.9%
Bicycles on Crosswalk	0	0	0	0	0	0	0	0	0	0	0	0	0	0	0	0	1
% Bicycles on Crosswalk	0.0%	0.0%	0.0%	0.0%	0.0%	0.0%	0.0%	0.0%	0.0%	0.0%	0.0%	0.0%	0.0%	0.0%	0.0%	0.0%	7.1%

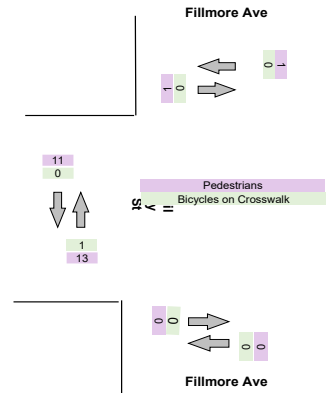
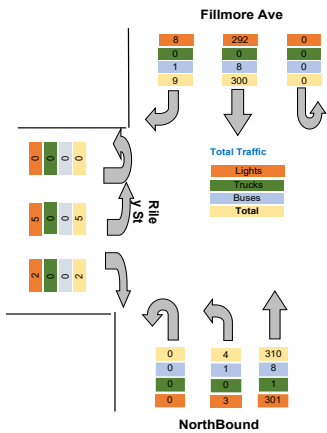

Intersection: Elm St Pine St
 Location: Kennett Square, PA
 Site: 01
 Survey Date: Wednesday, 04-28-2021
 GPS: 42.948550, -72.790034

Peds CCW	Total
1	41
0	65
1	106
0	60
2	72
1	96
1	147
4	375
0	119
0	119
0	238
1	153
2	166
6	163
2	189
11	671
6	153
0	146
3	142
5	146
14	587
30	1977
0.0%	0.0%
0.0%	0.0%
0	1841
0.0%	93.1%
0	4
0.0%	0.2%
0	132
0.0%	6.7%
29	0
96.7%	0.0%
1	0
3.3%	0.0%

Intersection: Elm St Pine St
 Location: Kennett Square, PA
 Site: 01
 Survey Date: Wednesday, 04-28-2021
 GPS: 42.948550, -72.790034



Peds CCW	Total
1	96
1	147
0	119
0	119
2	481
0.0%	
0.0%	
0.000	0.818
0	432
0.0%	89.8%
0	0
0.0%	0.0%
0	49
0.0%	10.2%
2	0
100.0%	0.0%
0	0
0.0%	0.0%

Intersection: Elm St Pine St
 Location: Kennett Square, PA
 Site: 01
 Survey Date: Wednesday, 04-28-2021
 GPS: 42.948550, -72.790034



Peds CCW	Total
2	189
6	153
0	146
3	142
11	630
0.0%	
0.0%	
0.000	0.833
0	611
0.0%	97.0%
0	1
0.0%	0.2%
0	18
0.0%	2.9%
11	0
100.0%	0.0%
0	0
0.0%	0.0%

Project	LaBella
Project Code	LaBella
Site Name	21
Legs and Movements	All Processed Legs & Movements
Bin Size	15 minutes
Survey Date	2021-11-04, Thursday
Location	21
Latitude and Longitude	42.909289, -78.839090

	Start	End	PHF
Forced Peak AM	2021/11/04 07:30:00	2021/11/04 08:30:00	0.878
Forced Peak PM	2021/11/04 16:30:00	2021/11/04 17:30:00	0.878
AM Peak	2021/11/04 07:30:00	2021/11/04 08:30:00	0.878
PM Peak	2021/11/04 16:45:00	2021/11/04 17:45:00	0.853

Turning Movement Data

Leg Direction	Fillmore Ave Southbound						Fillmore Ave Northbound						Riley St Eastbound					
	Right	Thru	U-Turn	App Total	Peds CW	Peds CCW	Thru	Left	U-Turn	App Total	Peds CW	Peds CCW	Right	Left	U-Turn	App Total	Peds CW	
Start Time																		
6:30:00 AM	0	19	0	19	0	0	13	0	0	13	0	0	1	1	0	2	0	0
6:45:00 AM	1	34	0	35	0	0	23	0	0	23	0	0	1	0	0	1	0	0
Hourly Total	1	53	0	54	0	0	36	0	0	36	0	0	2	1	0	3	0	0
7:00:00 AM	0	29	0	29	0	0	27	2	0	29	0	0	1	3	0	4	0	0
7:15:00 AM	0	34	0	34	0	0	23	0	0	23	0	0	0	0	0	0	1	0
7:30:00 AM	0	62	0	62	0	0	34	1	0	35	0	0	0	1	0	1	1	0
7:45:00 AM	0	71	0	71	1	0	45	0	0	45	0	0	0	1	0	1	0	0
Hourly Total	0	196	0	196	1	0	129	3	0	132	0	0	1	5	0	6	2	0
8:00:00 AM	0	83	0	83	0	0	53	0	0	53	0	0	1	0	0	1	0	0
8:15:00 AM	0	73	0	73	2	0	51	1	0	52	0	0	1	3	0	4	0	0
Hourly Total	0	156	0	156	2	0	104	1	0	105	0	0	2	3	0	5	0	0
4:00:00 PM	3	69	0	72	0	0	86	2	0	88	0	0	0	1	0	1	0	0
4:15:00 PM	1	86	0	87	0	0	70	1	0	71	0	0	1	3	0	4	4	0
4:30:00 PM	2	72	0	74	0	1	85	3	0	88	0	0	1	0	0	1	1	0
4:45:00 PM	3	90	0	93	0	0	95	1	0	96	0	0	4	2	0	6	4	0
Hourly Total	9	317	0	326	0	1	336	7	0	343	0	0	6	6	0	12	9	0
5:00:00 PM	3	71	0	74	0	0	90	1	0	91	0	0	0	2	0	2	1	0
5:15:00 PM	3	77	0	80	0	0	80	0	0	80	0	0	0	0	0	0	0	0
5:30:00 PM	0	75	0	75	0	0	65	1	0	66	1	0	2	0	0	2	1	0
5:45:00 PM	4	78	0	82	0	0	62	2	0	64	0	0	0	0	0	0	0	0
Hourly Total	10	301	0	311	0	0	297	4	0	301	1	0	2	2	0	4	2	0
Grand Total	20	1023	0	1043	3	1	902	15	0	917	1	0	13	17	0	30	13	0
% Approach	1.9%	98.1%	0.0%	0.0%	0.0%	0.0%	98.4%	1.6%	0.0%	0.0%	0.0%	0.0%	43.3%	56.7%	0.0%	0.0%	0.0%	0.0%
% Total	1.0%	51.4%	0.0%	52.4%	0.0%	0.0%	45.3%	0.8%	0.0%	46.1%	0.0%	0.0%	0.7%	0.9%	0.0%	1.5%	0.0%	0.0%
Lights	18	958	0	976	0	0	848	14	0	862	0	0	11	16	0	27	0	0
% Lights	90.0%	93.6%	0.0%	93.6%	0.0%	0.0%	94.0%	93.3%	0.0%	94.0%	0.0%	0.0%	84.6%	94.1%	0.0%	90.0%	0.0%	0.0%
Trucks	0	2	0	2	0	0	1	0	0	1	0	0	0	0	0	0	0	0
% Trucks	0.0%	0.2%	0.0%	0.2%	0.0%	0.0%	0.1%	0.0%	0.0%	0.1%	0.0%	0.0%	0.0%	0.0%	0.0%	0.0%	0.0%	0.0%
Buses	2	63	0	65	0	0	53	1	0	54	0	0	2	1	0	3	0	0
% Buses	10.0%	6.2%	0.0%	0.0%	0.0%	0.0%	0.0%	6.7%	0.0%	0.0%	0.0%	0.0%	15.4%	5.9%	0.0%	0.0%	0.0%	0.0%
Pedestrians	0	0	0	0	3	1	0	0	0	0	1	0	0	0	0	0	13	0
% Pedestrians	0.0%	0.0%	0.0%	0.0%	100.0%	100.0%	0.0%	0.0%	0.0%	0.0%	100.0%	0.0%	0.0%	0.0%	0.0%	0.0%	100.0%	0.0%
Bicycles on Crosswalk	0	0	0	0	0	0	0	0	0	0	0	0	0	0	0	0	0	0
% Bicycles on Crosswalk	0.0%	0.0%	0.0%	0.0%	0.0%	0.0%	0.0%	0.0%	0.0%	0.0%	0.0%	0.0%	0.0%	0.0%	0.0%	0.0%	0.0%	0.0%

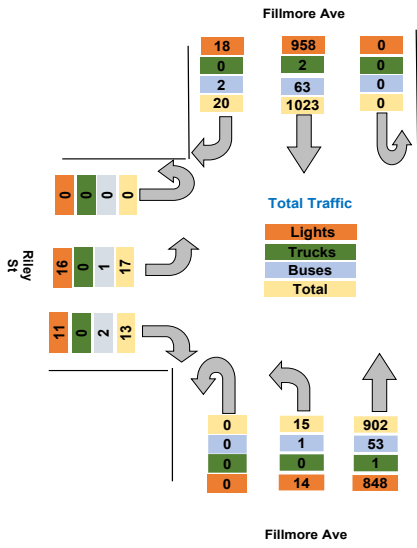

Turning Movement Data Plot

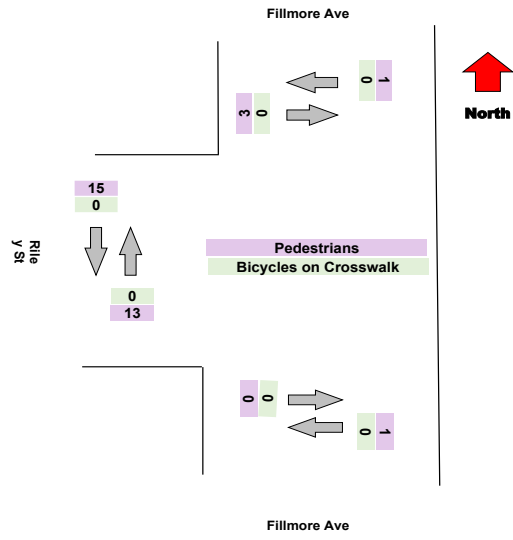

Turning Movement Peak Hour Data (AM)

7:30:00 AM

Leg Direction	Fillmore Ave Southbound						Fillmore Ave NorthBound						Riley St Eastbound					
	Right	Thru	U-Turn	App Total	Peds CW	Peds CCW	Thru	Left	U-Turn	App Total	Peds CW	Peds CCW	Right	Left	U-Turn	App Total	Peds CW	
7:30:00 AM	0	62	0	62	0	0	34	1	0	35	0	0	0	1	0	1	1	1
7:45:00 AM	0	71	0	71	1	0	45	0	0	45	0	0	0	1	0	1	0	0
8:00:00 AM	0	83	0	83	0	0	53	0	0	53	0	0	1	0	0	1	0	0
8:15:00 AM	0	73	0	73	2	0	51	1	0	52	0	0	1	3	0	4	0	0
Grand Total	0	289	0	289	3	0	183	2	0	185	0	0	2	5	0	7	1	1
% Approach	0.0%	100.0%	0.0%	0.0%	0.0%	0.0%	98.9%	1.1%	0.0%	0.0%	0.0%	0.0%	28.6%	71.4%	0.0%	0.0%	0.0%	0.0%
% Total	0.0%	60.1%	0.0%	60.1%	0.0%	0.0%	38.0%	0.4%	0.0%	38.5%	0.0%	0.0%	0.4%	1.0%	0.0%	1.5%	0.0%	0.0%
PHF	0.000	0.870	0.000	0.870	0.000	0.000	0.863	0.500	0.000	0.873	0.000	0.000	0.500	0.417	0.000	0.438	0.000	0.000
Lights	0	269	0	269	0	0	166	1	0	167	0	0	1	4	0	5	0	0
% Lights	0.0%	93.1%	0.0%	93.1%	0.0%	0.0%	90.7%	50.0%	0.0%	90.3%	0.0%	0.0%	50.0%	80.0%	0.0%	71.4%	0.0%	0.0%
Trucks	0	0	0	0	0	0	0	0	0	0	0	0	0	0	0	0	0	0
% Trucks	0.0%	0.0%	0.0%	0.0%	0.0%	0.0%	0.0%	0.0%	0.0%	0.0%	0.0%	0.0%	0.0%	0.0%	0.0%	0.0%	0.0%	0.0%
Buses	0	20	0	20	0	0	17	1	0	18	0	0	1	1	0	2	0	0
% Buses	0.0%	6.9%	0.0%	0.0%	0.0%	0.0%	9.3%	50.0%	0.0%	0.0%	0.0%	0.0%	50.0%	20.0%	0.0%	0.0%	0.0%	0.0%
Pedestrians	0	0	0	0	0	0	0	0	0	0	0	0	0	0	0	0	0	1
% Pedestrians	0.0%	0.0%	0.0%	0.0%	100.0%	0.0%	0.0%	0.0%	0.0%	0.0%	0.0%	0.0%	0.0%	0.0%	0.0%	0.0%	0.0%	100.0%
Bicycles on Crosswalk	0	0	0	0	0	0	0	0	0	0	0	0	0	0	0	0	0	0
% Bicycles on Crosswalk	0.0%	0.0%	0.0%	0.0%	0.0%	0.0%	0.0%	0.0%	0.0%	0.0%	0.0%	0.0%	0.0%	0.0%	0.0%	0.0%	0.0%	0.0%

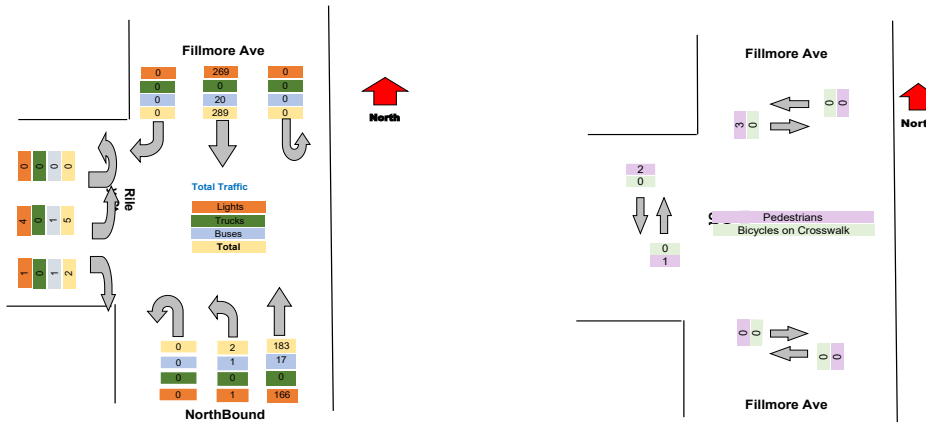

Turning Movement Peak Hour Data (PM)
 4:45:00 PM

Leg Direction	Fillmore Ave Southbound						Fillmore Ave Northbound						Riley St Eastbound				
	Right	Thru	U-Turn	App Total	Peds CW	Peds CCW	Thru	Left	U-Turn	App Total	Peds CW	Peds CCW	Right	Left	U-Turn	App Total	Peds CW
4:45:00 PM	3	90	0	93	0	0	95	1	0	96	0	0	4	2	0	6	4
5:00:00 PM	3	71	0	74	0	0	90	1	0	91	0	0	0	2	0	2	1
5:15:00 PM	3	77	0	80	0	0	80	0	0	80	0	0	0	0	0	0	0
5:30:00 PM	0	75	0	75	0	0	65	1	0	66	1	0	2	0	0	2	1
Grand Total	9	313	0	322	0	0	330	3	0	333	1	0	6	4	0	10	6
% Approach	2.8%	97.2%	0.0%	0.0%	0.0%	0.0%	99.1%	0.9%	0.0%	0.0%	0.0%	0.0%	60.0%	40.0%	0.0%	0.0%	0.0%
% Total	1.4%	47.1%	0.0%	48.4%	0.0%	0.0%	49.6%	0.5%	0.0%	50.1%	0.0%	0.0%	0.9%	0.6%	0.0%	1.5%	0.0%
PHF	0.750	0.869	0.000	0.866	0.000	0.000	0.868	0.750	0.000	0.867	0.000	0.000	0.375	0.500	0.000	0.417	0.000
Lights	9	301	0	310	0	0	321	3	0	324	0	0	6	4	0	10	0
% Lights	100.0%	96.2%	0.0%	96.3%	0.0%	0.0%	97.3%	100.0%	0.0%	97.3%	0.0%	0.0%	100.0%	100.0%	0.0%	100.0%	0.0%
Trucks	0	2	0	2	0	0	1	0	0	1	0	0	0	0	0	0	0
% Trucks	0.0%	0.6%	0.0%	0.6%	0.0%	0.0%	0.3%	0.0%	0.0%	0.3%	0.0%	0.0%	0.0%	0.0%	0.0%	0.0%	0.0%
Buses	0	10	0	10	0	0	8	0	0	8	0	0	0	0	0	0	0
% Buses	0.0%	3.2%	0.0%	0.0%	0.0%	0.0%	2.4%	0.0%	0.0%	0.0%	0.0%	0.0%	0.0%	0.0%	0.0%	0.0%	0.0%
Pedestrians	0	0	0	0	0	0	0	0	0	1	0	0	0	0	0	0	6
% Pedestrians	0.0%	0.0%	0.0%	0.0%	0.0%	0.0%	0.0%	0.0%	0.0%	0.0%	100.0%	0.0%	0.0%	0.0%	0.0%	0.0%	100.0%
Bicycles on Crosswalk	0	0	0	0	0	0	0	0	0	0	0	0	0	0	0	0	0
% Bicycles on Crosswalk	0.0%	0.0%	0.0%	0.0%	0.0%	0.0%	0.0%	0.0%	0.0%	0.0%	0.0%	0.0%	0.0%	0.0%	0.0%	0.0%	0.0%

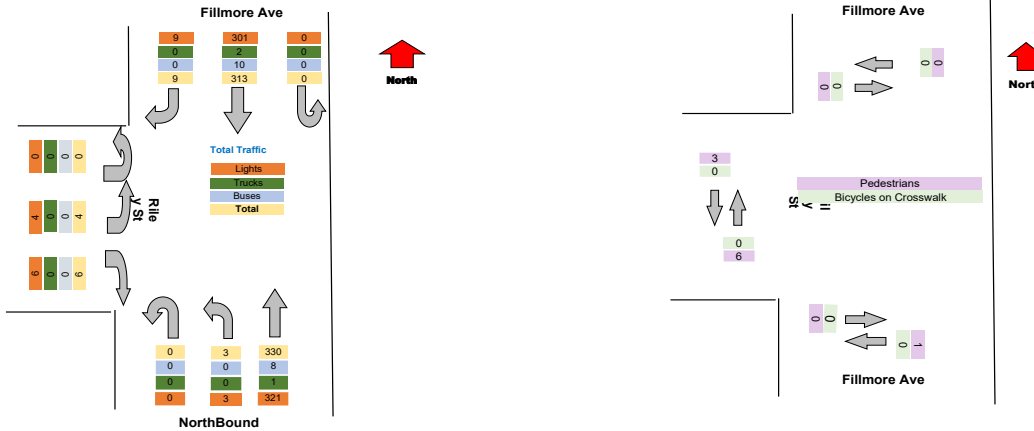

Intersection: Elm St Pine St
 Location: Kennett Square, PA
 Site: 01
 Survey Date: Wednesday, 04-28-2021
 GPS: 42.948550, -72.790034



Peds CCW	Total
0	34
2	59
2	93
1	62
1	57
2	98
0	117
4	334
0	137
0	129
0	266
3	161
0	162
2	163
0	195
5	681
1	167
0	160
2	143
1	146
4	616
15	1990
0.0%	0.0%
0.0%	0.0%
0	1865
0.0%	93.7%
0	3
0.0%	0.2%
0	122
0.0%	6.1%
15	0
100.0%	0.0%
0	0
0.0%	0.0%

Intersection: Elm St Pine St
 Location: Kennett Square, PA
 Site: 01
 Survey Date: Wednesday, 04-28-2021
 GPS: 42.948550, -72.790034



Peds CCW	Total
2	98
0	117
0	137
0	129
2	481
0.0%	
0.0%	
0.000	0.878
0	441
0.0%	91.7%
0	0
0.0%	0.0%
0	40
0.0%	8.3%
2	0
100.0%	0.0%
0	0
0.0%	0.0%

Intersection: Elm St Pine St
 Location: Kennett Square, PA
 Site: 01
 Survey Date: Wednesday, 04-28-2021
 GPS: 42.948550, -72.790034



Peds CCW	Total
0	195
1	167
0	160
2	143
3	665
0.0%	
0.0%	
0.000	0.853
0	644
0.0%	96.8%
0	3
0.0%	0.5%
0	18
0.0%	2.7%
3	0
100.0%	0.0%
0	0
0.0%	0.0%

Project : VBH Malta NY
Site : Site 4
Location : 42.948550, -73.790036

TSTData.com

Survey Date : 2021-04-28, Wednesday

Project	LaBella
Project Code	LaBella
Site Name	22
Legs and Movements	All Processed Legs & Move
Bin Size	15 minutes
Survey Date	2021-11-02, Tuesday
Location	22
Latitude and Longitude	42.910500, -78.839058

	Start	End	PHF
Forced Peak AM	2021/11/02 07:30:00	2021/11/02 08:30:00	0.89
Forced Peak PM	2021/11/02 16:30:00	2021/11/02 17:30:00	0.91
AM Peak	2021/11/02 07:30:00	2021/11/02 08:30:00	0.89
PM Peak	2021/11/02 16:45:00	2021/11/02 17:45:00	0.94

Turning Movement Data

Leg Direction	Fillmore Ave										French St										Fillmore Ave										Driveway										Total
	Southbound					Westbound					Northbound					Eastbound					Northbound					Eastbound															
	Right	Thru	Left	U-Turn	App Total	Right	Thru	Left	U-Turn	App Total	Right	Thru	Left	U-Turn	App Total	Right	Thru	Left	U-Turn	App Total	Right	Thru	Left	U-Turn	App Total	Right	Thru	Left	U-Turn	App Total	Right	Thru	Left	U-Turn	App Total						
6:30:00 AM	0	24	2	0	26	3	0	1	0	4	0	17	0	0	17	0	17	0	0	17	0	0	0	0	0	0	0	0	0	0	0	0	0	0	0						
6:45:00 AM	0	27	6	0	33	6	0	1	0	7	0	27	0	0	27	0	0	0	0	0	0	0	0	0	0	0	0	0	0	0	0	1	1	0	2						
Hourly Total	0	51	8	0	59	9	0	2	0	11	0	44	0	0	44	0	0	0	0	0	0	0	0	0	0	0	0	0	0	0	0	1	1	0	2						
7:00:00 AM	0	28	3	0	31	3	0	0	0	3	0	24	1	0	25	0	0	0	0	0	0	0	0	0	0	0	0	0	0	0	0	0	0	0	0						
7:15:00 AM	0	23	8	0	31	8	0	0	0	8	0	32	0	0	32	0	0	0	0	0	0	0	0	0	0	0	0	0	0	0	0	0	0	0	0						
7:30:00 AM	0	29	10	0	39	8	0	0	0	8	0	1	25	1	27	0	0	0	0	0	0	0	1	0	1	0	0	0	0	0	0	0	0	0	0						
7:45:00 AM	1	47	7	0	55	4	0	1	0	5	0	2	35	0	37	0	0	0	0	0	0	0	0	0	0	0	0	0	0	0	0	0	0	0	0						
Hourly Total	1	127	28	0	156	23	0	1	0	24	0	5	116	2	124	0	0	0	0	0	0	0	1	0	1	0	0	0	0	0	0	0	0	0	0						
8:00:00 AM	0	52	12	0	64	7	0	3	0	10	0	0	30	0	30	0	0	0	0	0	0	0	0	0	0	0	0	0	0	0	0	0	0	0	0						
8:15:00 AM	0	43	12	0	55	6	0	1	0	7	0	1	29	0	30	0	0	0	0	0	0	0	0	0	0	0	0	0	0	0	0	0	0	0	0						
Hourly Total	0	95	24	0	119	13	0	4	0	17	0	1	59	0	60	0	0	0	0	0	0	0	0	0	0	0	0	0	0	0	0	0	0	0	0						
4:00:00 PM	3	77	15	0	95	13	1	2	0	16	1	3	4	61	2	67	1	0	0	0	1	3	0	0	0	3	0	0	0	0	0	3	0	4	0	7					
4:15:00 PM	2	77	15	0	94	6	0	0	0	6	0	1	5	73	2	80	0	0	0	0	0	5	1	3	0	9	2	2	3	0	7										
4:30:00 PM	2	57	10	0	69	8	0	1	0	9	1	0	2	61	2	65	1	0	0	0	1	4	0	3	0	7	2	2	0	0	4										
4:45:00 PM	3	69	14	1	87	10	1	1	0	12	0	0	1	75	6	82	0	0	0	0	0	2	0	3	0	5	3	3	7	0	13										
Hourly Total	10	280	54	1	345	37	2	4	0	43	2	4	12	270	12	294	2	0	0	0	2	14	1	9	0	24	7	14	14	0	35										
5:00:00 PM	6	75	14	1	96	12	0	3	0	15	1	0	5	70	4	79	0	0	0	0	0	2	1	1	0	4	1	1	1	0	3										
5:15:00 PM	6	55	16	0	77	0	0	0	0	0	0	0	3	70	4	77	1	1	0	0	2	3	1	1	0	5	0	0	2	0	2										
5:30:00 PM	4	60	14	0	78	1	2	0	0	3	0	0	3	65	4	72	1	0	0	0	1	2	0	3	0	5	3	3	7	0	13										
5:45:00 PM	6	58	15	0	79	1	1	0	0	2	0	0	6	47	5	58	0	1	0	0	1	4	1	3	0	8	3	2	5	0	10										
Hourly Total	22	248	59	1	330	39	4	14	0	57	1	0	17	252	17	286	2	2	0	0	4	11	3	8	0	22	7	8	14	0	29										
Grand Total	33	801	173	2	1009	121	6	25	0	152	4	6	35	741	31	809	4	2	0	0	6	25	4	18	0	47	15	24	24	0	63										
% Approach	3.3%	79.4%	17.1%	0.2%	0.0%	79.6%	3.9%	16.4%	0.0%	0.0%	4.3%	91.6%	3.8%	0.0%	0.0%	53.2%	8.5%	38.3%	0.0%	0.0%	1.2%	0.2%	0.9%	0.0%	2.3%	0.0%	0.0%	0.0%	0.0%	0.0%											
% Total	1.6%	39.7%	8.6%	0.1%	50.0%	6.0%	0.3%	1.2%	0.0%	7.5%	1.7%	36.7%	1.5%	0.0%	40.1%	1.2%	0.2%	0.9%	0.0%	2.3%	0.0%	0.0%	0.0%	0.0%	0.0%	0.0%	0.0%	0.0%	0.0%	0.0%											
Lights	33	773	157	2	965	106	6	24	0	136	0	0	34	717	31	782	0	0	0	0	0	25	4	18	0	47	0	0	0	0	0										
% Lights	100.0%	96.5%	93.9%	100.0%	95.6%	87.6%	100.0%	96.0%	0.0%	89.5%	0.0%	0.0%	87.1%	96.8%	100.0%	96.7%	0.0%	0.0%	100.0%	100.0%	100.0%	100.0%	100.0%	100.0%	0.0%	100.0%	0.0%	0.0%	0.0%	0.0%	95.7%										
Trucks	0	2	0	0	2	0	0	0	0	0	0	0	0	2	0	2	0	0	0	0	0	0	0	0	0	0	0	0	0	0	0										
% Trucks	0.0%	0.2%	0.0%	0.0%	0.2%	0.0%	0.0%	0.0%	0.0%	0.0%	0.0%	0.0%	0.0%	0.2%	0.0%	0.2%	0.0%	0.0%	0.0%	0.0%	0.0%	0.0%	0.0%	0.0%	0.0%	0.0%	0.0%	0.0%	0.0%	0.0%	0.2%										
Buses	0	25	16	0	41	0	0	0	0	0	0	0	1	21	0	22	0	0	0	0	0	0	0	0	0	0	0	0	0	0	0										
% Buses	0.0%	3.1%	9.2%	0.0%	0.0%	0.0%	0.0%	4.0%	0.0%	0.0%	0.0%	0.0%	2.9%	2.8%	0.0%	0.0%	0.0%	0.0%	0.0%	0.0%	0.0%	0.0%	0.0%	0.0%	0.0%	0.0%	0.0%	0.0%	0.0%	0.0%	3.9%										
Pedestrians	0	0	0	0	0	0	0	0	0	0	4	4	0	0	0	0	4	2	0	0	0	0	0	0	0	0	0	15	23	0	38										
% Pedestrians	0.0%	0.0%	0.0%	0.0%	0.0%	0.0%	0.0%	0.0%	0.0%	0.0%	100.0%	80.0%	0.0%	0.0%	0.0%	0.0%	100.0%	100.0%	0.0%	0.0%	0.0%	0.0%	0.0%	0.0%	0.0%	0.0%	100.0%	85.8%	85.8%	0.0%	0.0%										
Bicycles on Crosswalk	0	0	0	0	0	0	0	0	0	0	1	0	0	0	0	0	0	0	0	0	0	0	0	0	0	0	0	0	0	0	0										
% Bicycles on Crosswalk	0.0%	0.0%	0.0%	0.0%	0.0%	0.0%	0.0%	0.0%	0.0%	0.0%	20.0%	0.0%	0.0%	0.0%	0.0%	0.0%	0.0%	0.0%	0.0%	0.0%	0.0%	0.0%	0.0%	0.0%	0.0%	0.0%	0.0%	0.0%	0.0%	0.0%	0.0%										

Project : VBH Malta NY
 Site : Site 4
 Location : 42.948550, -73.790036
 Survey Date : 2021-04-28, Wednesday

Turning Movement Data Plot

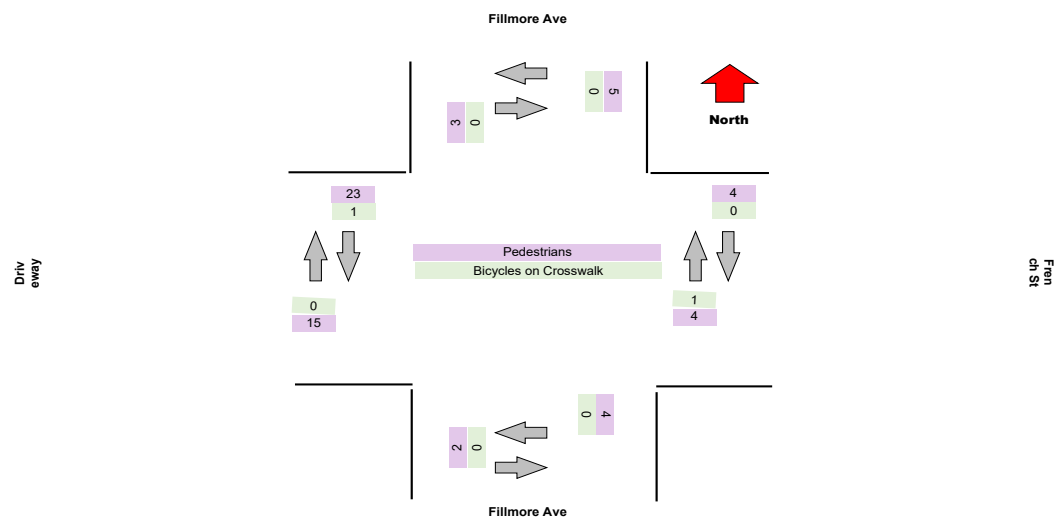
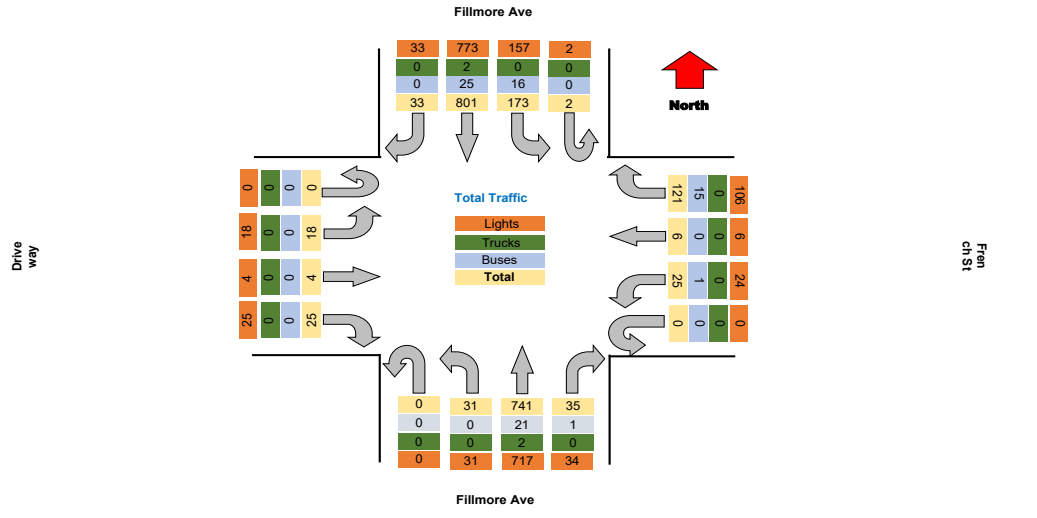

Project : VBH Malta NY
Site : Site 4
Location : 42.948550, -73.790036

TSTData.com

Survey Date : 2021-04-28, Wednesday

Turning Movement Peak Hour Data (AM)

7:30:00 AM

Leg Direction	Fillmore Ave				French St				Fillmore Ave				Driveway				Total							
	Southbound		Westbound		Northbound		Eastbound																	
Start Time	Right	Thru	Left	U-Turn	App Total	Peds CW	Peds CCW	Right	Thru	Left	U-Turn	App Total	Peds CW	Peds CCW	Right	Thru	Left	U-Turn	App Total	Peds CW	Peds CCW			
7:30:00 AM	0	29	10	0	39	0	0	8	0	0	0	8	0	0	1	25	1	0	28	0	0	0	76	
7:45:00 AM	1	47	7	0	55	0	0	4	0	1	0	5	0	0	2	35	0	0	37	0	0	0	97	
8:00:00 AM	0	52	12	0	64	0	0	7	0	3	0	10	0	0	0	30	0	0	30	0	0	0	104	
8:15:00 AM	0	43	12	0	55	0	0	6	0	1	0	7	0	0	1	29	0	0	30	0	0	0	92	
Grand Total	1	171	41	0	213	0	0	25	0	5	0	39	0	0	4	119	1	0	125	0	0	0	389	
% Approach	0.5%	89.3%	19.2%	0.0%	0.0%	0.0%	0.0%	83.3%	0.0%	16.7%	0.0%	0.0%	0.0%	0.0%	3.2%	95.2%	0.8%	0.0%	0.0%	0.0%	0.0%	0.0%	0.0%	0.0%
% Total	0.3%	46.3%	11.1%	0.0%	57.7%	0.0%	0.0%	6.8%	0.0%	1.4%	0.0%	8.1%	0.0%	0.0%	1.1%	32.2%	0.3%	0.0%	33.9%	0.0%	0.0%	0.0%	0.0%	
PHF	0.250	0.822	0.854	0.000	0.832	0.000	0.000	0.781	0.000	0.417	0.000	0.750	0.000	0.000	0.500	0.850	0.250	0.000	0.845	0.000	0.000	0.000	0.887	
Lights	1	165	37	0	203	0	0	20	0	4	0	24	0	0	4	111	1	0	116	0	0	0	344	
% Lights	100.0%	96.5%	90.2%	0.0%	95.3%	0.0%	0.0%	80.0%	0.0%	80.0%	0.0%	80.0%	0.0%	0.0%	100.0%	93.3%	100.0%	0.0%	92.8%	0.0%	0.0%	0.0%	93.2%	
Trucks	0	0	0	0	0	0	0	0	0	0	0	0	0	0	0	0	0	0	0	0	0	0	0	
% Trucks	0.0%	0.0%	0.0%	0.0%	0.0%	0.0%	0.0%	0.0%	0.0%	0.0%	0.0%	0.0%	0.0%	0.0%	0.0%	0.0%	0.0%	0.0%	0.0%	0.0%	0.0%	0.0%	0.0%	
Buses	0	6	4	0	10	0	0	5	0	1	0	6	0	0	0	8	0	0	8	0	0	0	24	
% Buses	0.0%	3.5%	9.8%	0.0%	0.0%	0.0%	0.0%	20.0%	0.0%	20.0%	0.0%	0.0%	0.0%	0.0%	0.0%	6.7%	0.0%	0.0%	0.0%	0.0%	0.0%	0.0%	6.8%	
Pedestrians	0	0	0	0	0	0	0	0	0	0	0	0	0	0	0	0	0	0	0	0	0	0	0	
% Pedestrians	0.0%	0.0%	0.0%	0.0%	0.0%	0.0%	0.0%	0.0%	0.0%	0.0%	0.0%	0.0%	0.0%	100.0%	0.0%	0.0%	0.0%	0.0%	0.0%	0.0%	0.0%	0.0%	100.0%	
Bicycles on Crosswalk	0	0	0	0	0	0	0	0	0	0	0	0	0	0	0	0	0	0	0	0	0	0	0	
% Bicycles on Crosswalk	0.0%	0.0%	0.0%	0.0%	0.0%	0.0%	0.0%	0.0%	0.0%	0.0%	0.0%	0.0%	0.0%	0.0%	0.0%	0.0%	0.0%	0.0%	0.0%	0.0%	0.0%	0.0%	0.0%	

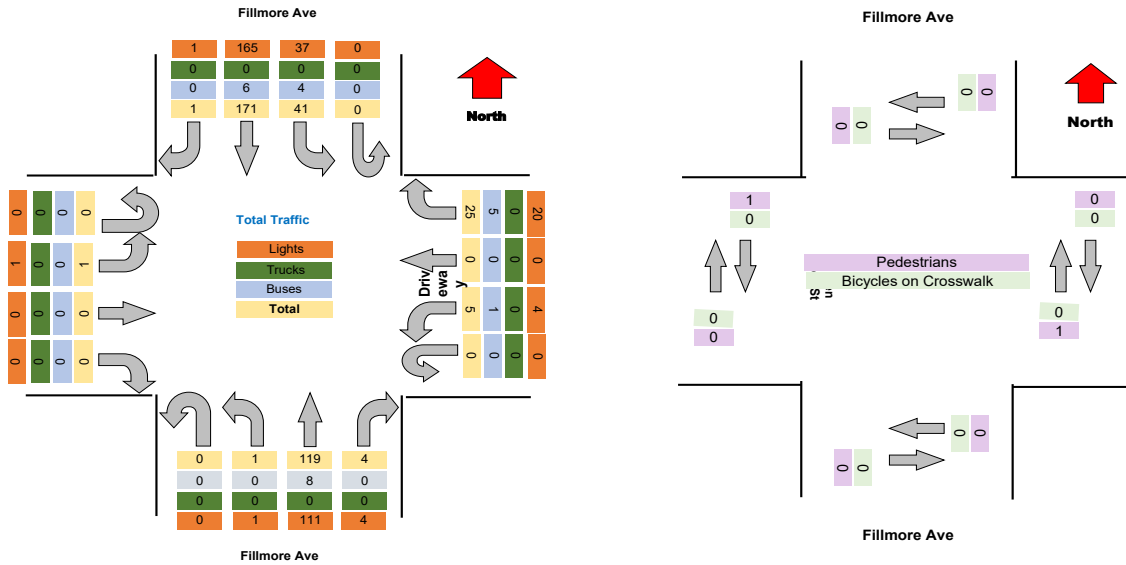

Project : VBH Malta NY
Site : Site 4
Location : 42.948550, -73.790036

TSTData.com

Survey Date : 2021-04-28, Wednesday

Turning Movement Peak Hour Data (PM)

4:45:00 PM

Leg Direction	Fillmore Ave				French St				Fillmore Ave				Driveway				Total												
	Southbound				Westbound				Northbound				Eastbound																
Start Time	Right	Thru	Left	U-Turn	App Total	Peds CW	Peds CCW	Right	Thru	Left	U-Turn	App Total	Peds CW	Peds CCW	Right	Thru	Left	U-Turn	App Total	Peds CW	Peds CCW								
4:45:00 PM	3	69	14	1	87	0	0	10	1	1	0	12	0	0	1	75	6	0	82	0	0	2	0	3	0	5	3	7	186
5:00:00 PM	6	75	14	1	96	1	0	12	0	3	0	15	1	0	5	70	4	0	79	0	0	2	1	1	0	4	1	1	194
5:15:00 PM	6	55	16	0	77	0	0	13	0	3	0	16	0	0	3	70	4	0	77	1	1	3	1	1	0	5	0	2	175
5:30:00 PM	4	60	14	0	78	0	0	9	3	4	0	16	0	0	3	65	4	0	72	1	0	2	0	3	0	5	3	3	171
Grand Total	19	259	58	2	338	0	0	44	4	11	0	59	1	0	12	290	18	0	310	2	1	9	2	8	0	19	7	13	726
% Approach	5.6%	76.6%	17.2%	0.6%	0.0%	0.0%	0.0%	74.6%	6.8%	18.6%	0.0%	0.0%	0.0%	0.0%	3.9%	90.3%	5.8%	0.0%	0.0%	0.0%	0.0%	47.4%	10.5%	42.1%	0.0%	0.0%	0.0%	0.0%	186
% Total	2.6%	35.7%	8.0%	0.3%	46.6%	0.0%	0.0%	6.1%	0.6%	1.5%	0.0%	8.1%	0.0%	0.0%	1.7%	38.6%	2.5%	0.0%	42.7%	0.0%	0.0%	1.2%	0.3%	1.1%	0.0%	2.6%	0.0%	0.0%	175
PHF	0.792	0.863	0.906	0.500	0.890	0.000	0.000	0.846	0.333	0.688	0.000	0.922	0.000	0.000	0.600	0.933	0.750	0.000	0.845	0.000	0.000	0.750	0.500	0.667	0.000	0.950	0.000	0.000	0.936
Lights	19	251	55	2	327	0	0	41	4	11	0	56	0	0	12	273	18	0	303	0	0	9	2	8	0	19	0	0	705
% Lights	100.0%	96.9%	94.8%	100.0%	96.7%	0.0%	0.0%	83.2%	100.0%	100.0%	0.0%	94.9%	0.0%	0.0%	100.0%	97.6%	100.0%	0.0%	97.7%	0.0%	0.0%	100.0%	100.0%	100.0%	0.0%	100.0%	0.0%	0.0%	97.1%
Trucks	0	1	0	0	1	0	0	0	0	0	0	0	0	0	0	2	0	0	2	0	0	0	0	0	0	0	0	0	3
% Trucks	0.0%	0.4%	0.0%	0.0%	0.3%	0.0%	0.0%	0.0%	0.0%	0.0%	0.0%	0.0%	0.0%	0.0%	0.0%	0.7%	0.0%	0.0%	0.6%	0.0%	0.0%	0.0%	0.0%	0.0%	0.0%	0.0%	0.0%	0.0%	0.4%
Buses	0	7	3	0	10	0	0	3	0	0	0	3	0	0	0	4	0	0	4	0	0	0	0	0	0	0	0	0	17
% Buses	0.0%	2.7%	5.2%	0.0%	0.0%	0.0%	0.0%	6.8%	0.0%	0.0%	0.0%	0.0%	0.0%	0.0%	0.0%	1.4%	0.0%	0.0%	0.0%	0.0%	0.0%	0.0%	0.0%	0.0%	0.0%	0.0%	0.0%	0.0%	2.3%
Pedestrians	0	0	0	0	0	2	2	0	0	0	0	0	1	0	0	0	0	0	0	2	1	0	0	0	0	0	7	13	0
% Pedestrians	0.0%	0.0%	0.0%	0.0%	0.0%	100.0%	100.0%	0.0%	0.0%	0.0%	0.0%	0.0%	100.0%	100.0%	0.0%	0.0%	0.0%	0.0%	0.0%	100.0%	100.0%	0.0%	0.0%	0.0%	0.0%	0.0%	100.0%	100.0%	0.0%
Bicycles on Crosswalk	0	0	0	0	0	0	0	0	0	0	0	0	0	0	0	0	0	0	0	0	0	0	0	0	0	0	0	0	0
% Bicycles on Crosswalk	0.0%	0.0%	0.0%	0.0%	0.0%	0.0%	0.0%	0.0%	0.0%	0.0%	0.0%	0.0%	0.0%	0.0%	0.0%	0.0%	0.0%	0.0%	0.0%	0.0%	0.0%	0.0%	0.0%	0.0%	0.0%	0.0%	0.0%	0.0%	0.0%

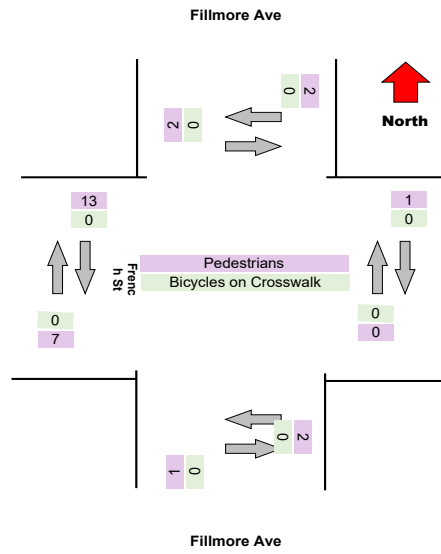
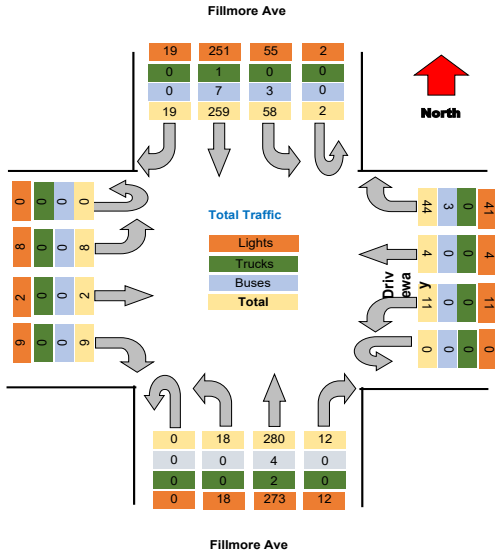

Project : VBH Malta NY
 Site : Site 4
 Location : 42.948550, -73.790036
 Survey Date : 2021-04-28, Wednesday

Turning Movement Data Plot

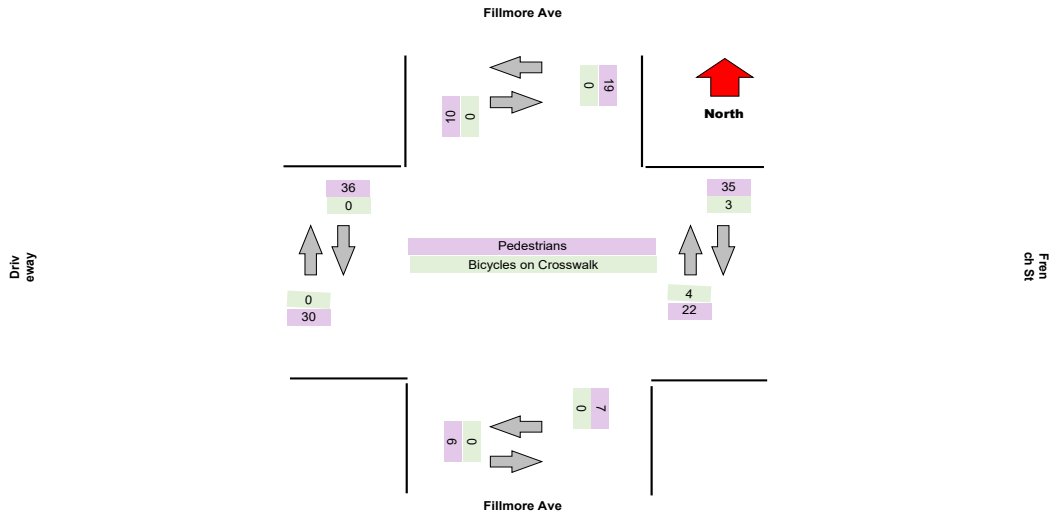
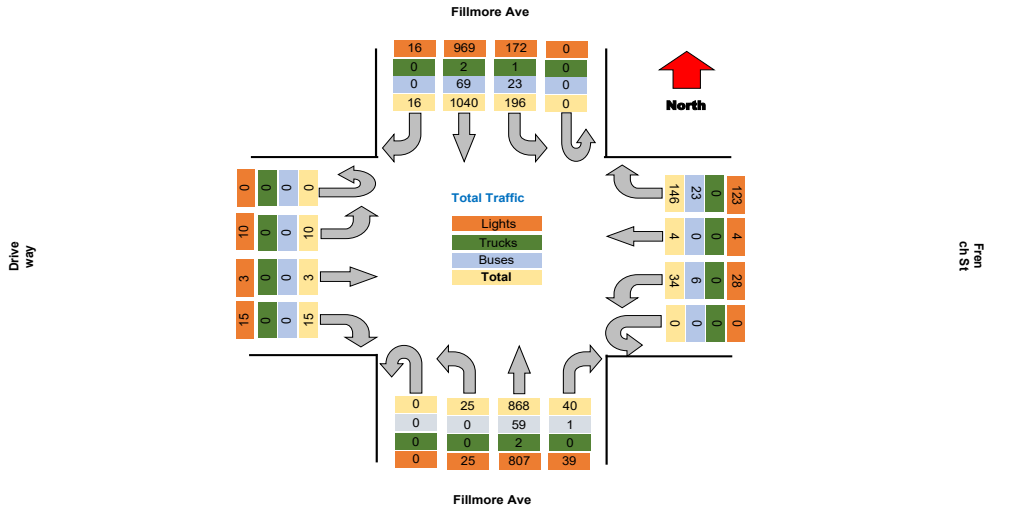

Project : VBH Malta NY
Site : Site 4
Location : 42.948550, -73.790036

TSTData.com

Survey Date : 2021-04-28, Wednesday

Turning Movement Peak Hour Data (AM)

7:30:00 AM

Leg Direction	Fillmore Ave Southbound					French St Westbound					Fillmore Ave Northbound					Driveway Eastbound					Total					
	Right	Thru	Left	U-Turn	App Total	Peds CW	Peds CCW	Right	Thru	Left	U-Turn	App Total	Peds CW	Peds CCW	Right	Thru	Left	U-Turn	App Total	Peds CW		Peds CCW				
7:30:00 AM	0	59	7	0	66	1	2	6	0	2	0	10	8	3	0	37	0	0	48	0	2	1	1	1	125	
7:45:00 AM	0	81	12	0	93	0	0	10	0	2	0	12	8	0	0	1	60	0	0	69	0	0	0	0	1	174
8:00:00 AM	0	72	15	0	87	0	1	7	0	1	0	9	0	1	0	0	48	0	0	49	0	0	0	1	0	146
8:15:00 AM	0	68	10	0	78	0	0	9	0	0	0	9	0	0	0	3	56	0	0	66	1	0	0	0	1	153
Grand Total	0	289	44	0	324	1	3	32	0	5	0	49	22	5	4	231	0	0	232	1	4	1	1	2	598	
% Approach	0.0%	86.4%	13.6%	0.0%	0.0%	0.0%	0.0%	80.0%	0.0%	12.5%	0.0%	0.0%	0.0%	0.0%	1.7%	86.6%	0.0%	0.0%	0.0%	0.0%	0.0%	50.0%	50.0%	0.0%	0.0%	
% Total	0.0%	46.8%	7.4%	0.0%	54.2%	0.0%	0.0%	5.4%	0.0%	0.8%	0.0%	6.7%	0.0%	0.0%	0.7%	33.6%	0.0%	0.0%	38.8%	0.0%	0.0%	0.2%	0.2%	0.0%	0.3%	
PHF	0.000	0.864	0.733	0.000	0.871	0.000	0.000	0.800	0.000	0.625	0.000	0.833	0.000	0.000	0.333	0.838	0.000	0.000	0.841	0.000	0.000	0.250	0.250	0.000	0.500	
Lights	0	261	39	0	300	0	0	24	0	2	0	26	0	0	4	177	0	0	181	0	0	1	1	0	2	
% Lights	0.0%	93.2%	88.6%	0.0%	92.6%	0.0%	0.0%	75.0%	0.0%	40.0%	0.0%	65.0%	0.0%	0.0%	100.0%	88.1%	0.0%	0.0%	78.0%	0.0%	0.0%	100.0%	100.0%	0.0%	100.0%	
Trucks	0	0	0	0	0	0	0	0	0	0	0	0	0	0	0	0	0	0	0	0	0	0	0	0	0	
% Trucks	0.0%	0.0%	0.0%	0.0%	0.0%	0.0%	0.0%	0.0%	0.0%	0.0%	0.0%	0.0%	0.0%	0.0%	0.0%	0.0%	0.0%	0.0%	0.0%	0.0%	0.0%	0.0%	0.0%	0.0%	0.0%	
Buses	0	19	5	0	24	0	0	8	0	3	0	11	0	0	0	24	0	0	24	0	0	0	0	0	0	
% Buses	0.0%	6.8%	11.4%	0.0%	0.0%	0.0%	0.0%	25.0%	0.0%	60.0%	0.0%	0.0%	0.0%	0.0%	0.0%	11.9%	0.0%	0.0%	0.0%	0.0%	0.0%	0.0%	0.0%	0.0%	0.0%	
Pedestrians	0	0	0	0	0	1	3	0	0	0	0	0	21	5	0	0	0	0	1	4	0	0	0	0	2	
% Pedestrians	0.0%	0.0%	0.0%	0.0%	0.0%	100.0%	100.0%	0.0%	0.0%	0.0%	0.0%	0.0%	95.9%	100.0%	0.0%	0.0%	0.0%	0.0%	0.0%	100.0%	100.0%	0.0%	0.0%	0.0%	100.0%	
Bicycles on Crosswalk	0	0	0	0	0	0	0	0	0	0	0	1	0	0	0	0	0	0	0	0	0	0	0	0	0	
% Bicycles on Crosswalk	0.0%	0.0%	0.0%	0.0%	0.0%	0.0%	0.0%	0.0%	0.0%	0.0%	0.0%	4.5%	0.0%	0.0%	0.0%	0.0%	0.0%	0.0%	0.0%	0.0%	0.0%	0.0%	0.0%	0.0%	0.0%	

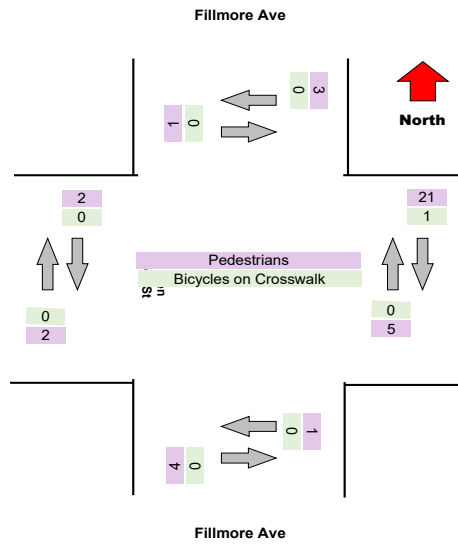
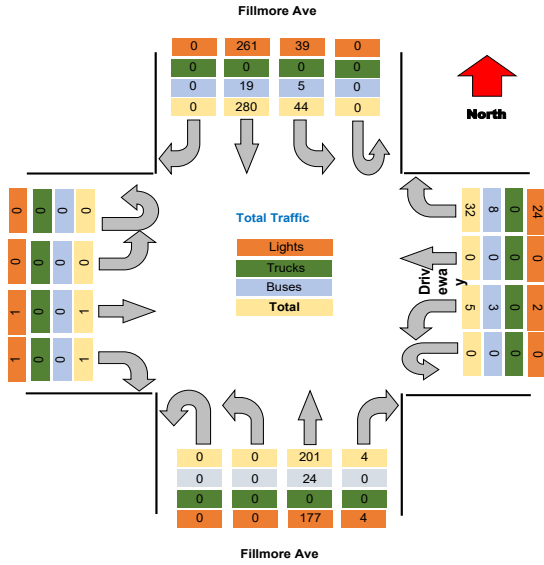

Project : VBH Malta NY
Site : Site 4
Location : 42.948550, -73.790036

TSTData.com

Survey Date : 2021-04-28, Wednesday

Turning Movement Peak Hour Data (PM)

4:45:00 PM

Leg Direction	Fillmore Ave					French St					Fillmore Ave					Driveway					Total							
	Southbound					Westbound					Northbound					Eastbound												
Start Time	Right	Thru	Left	U-Turn	App Total	Peds CW	Peds CCW	Right	Thru	Left	U-Turn	App Total	Peds CW	Peds CCW	Right	Thru	Left	U-Turn	App Total	Peds CW	Peds CCW	Total						
4:45:00 PM	2	83	13	0	98	0	1	9	0	1	0	10	0	2	5	90	4	0	99	0	0	208						
5:00:00 PM	3	75	15	0	93	2	1	11	2	2	0	15	1	4	5	73	4	0	82	0	0	196						
5:15:00 PM	2	78	18	0	98	0	2	9	1	4	0	14	0	2	3	67	0	0	70	0	0	187						
5:30:00 PM	0	58	17	0	65	1	1	16	0	4	0	20	0	1	3	52	3	0	58	0	3	178						
Grand Total	7	304	63	0	374	3	5	45	3	11	0	59	1	9	16	292	11	0	319	0	3	768						
% Approach	1.9%	81.3%	16.8%	0.0%	0.0%	0.0%	0.0%	76.3%	5.1%	18.6%	0.0%	0.0%	0.0%	0.0%	5.0%	91.5%	3.4%	0.0%	0.0%	0.0%	0.0%	68.8%	6.3%	25.0%	0.0%	0.0%	0.0%	
% Total	0.9%	39.6%	8.2%	0.0%	48.7%	0.0%	0.0%	5.9%	0.4%	1.4%	0.0%	7.7%	0.0%	0.0%	2.1%	38.0%	1.4%	0.0%	41.5%	0.0%	0.0%	1.4%	0.1%	0.5%	0.0%	2.1%	0.0%	0.0%
PHF	0.583	0.916	0.875	0.000	0.954	0.000	0.000	0.703	0.375	0.688	0.000	0.738	0.000	0.000	0.800	0.811	0.688	0.000	0.806	0.000	0.000	0.550	0.250	0.333	0.000	0.800	0.000	0.000
Lights	7	296	58	0	361	0	0	40	3	11	0	54	0	0	16	282	11	0	309	0	0	740						
% Lights	100.0%	97.4%	92.1%	0.0%	96.5%	0.0%	0.0%	88.9%	100.0%	100.0%	0.0%	91.5%	0.0%	0.0%	100.0%	96.6%	100.0%	0.0%	96.9%	0.0%	0.0%	100.0%						
Trucks	0	0	0	0	0	0	0	0	0	0	0	0	0	0	0	1	0	0	1	0	0	1						
% Trucks	0.0%	0.0%	0.0%	0.0%	0.0%	0.0%	0.0%	0.0%	0.0%	0.0%	0.0%	0.0%	0.0%	0.0%	0.0%	0.3%	0.0%	0.0%	0.3%	0.0%	0.0%	0.1%						
Buses	0	8	5	0	13	0	0	5	0	0	0	5	0	0	0	9	0	0	9	0	0	27						
% Buses	0.0%	2.6%	7.9%	0.0%	0.0%	0.0%	0.0%	11.1%	0.0%	0.0%	0.0%	0.0%	0.0%	0.0%	0.0%	3.1%	0.0%	0.0%	0.0%	0.0%	0.0%	3.5%						
Pedestrians	0	0	0	0	0	3	5	0	0	0	0	1	6	0	0	0	0	0	0	3	0	9						
% Pedestrians	0.0%	0.0%	0.0%	0.0%	0.0%	100.0%	100.0%	0.0%	0.0%	0.0%	0.0%	0.0%	66.7%	0.0%	0.0%	0.0%	0.0%	0.0%	0.0%	0.0%	100.0%	100.0%						
Bicycles on Crosswalk	0	0	0	0	0	0	0	0	0	0	0	0	0	0	0	0	0	0	0	0	0	0						
% Bicycles on Crosswalk	0.0%	0.0%	0.0%	0.0%	0.0%	0.0%	0.0%	0.0%	0.0%	0.0%	0.0%	0.0%	0.0%	0.0%	0.0%	0.0%	0.0%	0.0%	0.0%	0.0%	0.0%	0.0%						

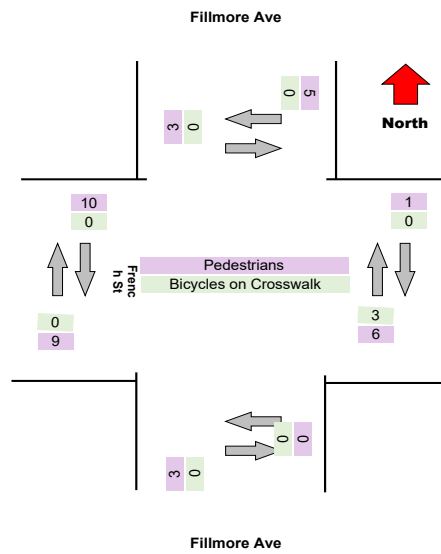
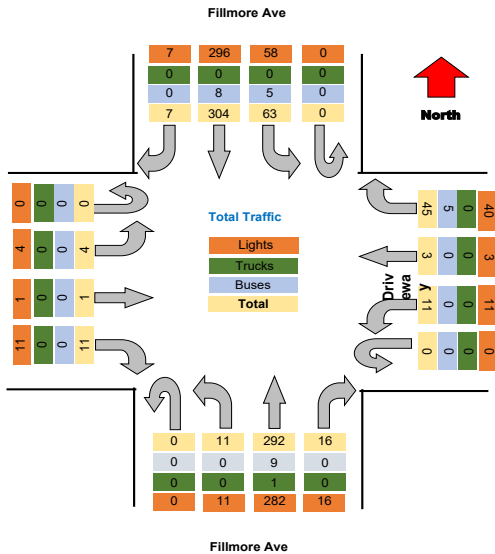

Project : VBH Malta NY
Site : Site 4
Location : 42.948550, -73.790036

TSTData.com

Survey Date : 2021-04-28, Wednesday

Project	LaBella
Project Code	LaBella
Site Name	22
Legs and Movements	All Processed Legs & Move
Bin Size	15 minutes
Survey Date	2021-11-04, Thursday
Location	22
Latitude and Longitude	42.910500, -78.839058

	Start	End	PHF
Forced Peak AM	2021/11/04 07:30:00	2021/11/04 08:30:00	0.96
Forced Peak PM	2021/11/04 16:30:00	2021/11/04 17:30:00	0.91
AM Peak	2021/11/04 07:30:00	2021/11/04 08:30:00	0.96
PM Peak	2021/11/04 16:45:00	2021/11/04 17:45:00	0.88

Turning Movement Data

Leg Direction	Fillmore Ave							French St							Fillmore Ave							Driveway							Total	
	Southbound							Westbound							Northbound							Eastbound								
Start Time	Right	Thru	Left	U-Turn	App Total	Peds CV	Peds CCV	Right	Thru	Left	U-Turn	App Total	Peds CV	Peds CCV	Right	Thru	Left	U-Turn	App Total	Peds CV	Peds CCV	Right	Thru	Left	U-Turn	App Total	Peds CV	Peds CCV		
6:30:00 AM	0	17	5	0	22	0	0	4	0	1	0	5	0	0	0	12	0	0	12	0	0	0	0	0	0	0	0	0	0	39
6:45:00 AM	0	25	4	0	39	0	0	5	0	0	0	5	0	0	0	26	0	0	26	0	0	0	0	0	0	0	0	0	1	70
Hourly Total	0	52	9	0	61	0	0	9	0	1	0	10	0	0	0	38	0	0	38	0	0	0	0	0	0	0	0	0	2	109
7:00:00 AM	0	32	5	0	37	0	1	6	0	0	0	7	2	0	0	29	0	0	31	1	0	0	0	0	0	0	0	1	75	
7:15:00 AM	0	37	5	0	42	0	0	4	0	4	0	8	0	2	0	31	0	0	33	0	0	0	0	0	0	0	0	1	83	
7:30:00 AM	0	65	9	0	74	2	0	9	0	2	0	11	8	2	1	36	0	0	47	0	1	1	1	0	0	0	1	1	133	
7:45:00 AM	0	71	10	0	81	0	2	8	0	3	0	13	12	0	0	47	0	0	59	0	0	0	0	0	0	0	0	1	153	
Hourly Total	0	205	29	0	234	2	3	27	0	9	0	39	22	4	1	143	0	0	170	1	1	1	0	0	0	0	1	4	5	444
8:00:00 AM	0	83	13	0	96	1	1	4	0	4	0	9	4	1	1	46	0	0	52	0	0	0	0	0	0	0	1	1	157	
8:15:00 AM	0	75	7	0	82	0	0	11	0	2	0	13	1	0	1	59	0	0	61	0	0	0	0	1	0	0	1	1	157	
Hourly Total	0	158	20	0	178	1	1	15	0	6	0	22	5	1	2	105	0	0	113	0	0	0	0	1	0	0	1	2	1	314
4:00:00 PM	5	73	14	0	92	2	4	10	0	2	0	12	1	2	4	83	0	0	87	0	2	3	0	1	0	4	1	6	195	
4:15:00 PM	1	86	20	0	107	0	4	7	0	1	0	8	0	1	4	68	5	0	77	0	1	1	1	1	0	3	5	5	195	
4:30:00 PM	5	86	12	0	93	0	1	10	1	6	0	19	0	4	2	85	3	0	90	0	2	6	0	2	0	8	3	7	200	
4:45:00 PM	2	88	25	0	115	3	3	11	0	0	0	11	0	0	5	89	4	0	95	1	2	8	1	3	0	13	4	3	236	
Hourly Total	13	313	71	0	397	4	12	38	1	11	0	50	1	7	15	325	12	0	352	1	7	18	2	7	0	27	13	21	826	
5:00:00 PM	4	78	22	0	104	3	4	15	0	3	0	18	3	1	3	87	5	0	95	1	1	2	0	0	0	2	5	7	219	
5:15:00 PM	3	80	11	0	94	1	1	19	0	1	0	20	0	1	2	78	6	0	86	0	0	2	1	2	0	5	0	1	205	
5:30:00 PM	1	70	13	0	84	0	0	9	0	7	0	16	6	0	1	68	1	0	70	3	0	3	0	2	0	5	5	2	175	
5:45:00 PM	2	86	10	0	88	0	1	14	0	1	0	15	1	0	4	57	1	0	62	0	0	4	1	5	0	10	2	2	185	
Hourly Total	10	314	56	0	380	4	6	57	0	12	0	69	10	2	10	290	13	0	313	4	1	11	2	9	0	22	12	12	784	
Grand Total	23	1042	185	0	1250	11	22	146	1	39	0	190	38	14	28	901	25	0	986	6	9	30	5	16	0	51	31	41	2477	
% Approach	1.6%	83.4%	14.8%	0.0%	0.0%	0.0%	0.0%	76.8%	0.5%	20.5%	0.0%	0.0%	0.0%	0.0%	2.8%	91.4%	2.5%	0.0%	0.0%	0.0%	0.0%	58.8%	9.8%	31.4%	0.0%	0.0%	0.0%	0.0%	0.0%	0.0%
% Total	0.9%	42.1%	7.5%	0.0%	50.5%	0.0%	0.0%	5.9%	0.0%	1.6%	0.0%	7.7%	0.0%	0.0%	1.1%	36.4%	1.0%	0.0%	38.8%	0.0%	0.0%	1.2%	0.2%	0.6%	0.0%	2.1%	0.0%	0.0%	0.0%	0.0%
Lights	23	980	160	0	1163	0	0	127	1	33	0	161	0	0	24	846	25	0	895	0	0	30	5	16	0	51	0	0	2270	
% Lights	100.0%	94.0%	85.5%	0.0%	93.0%	0.0%	0.0%	87.0%	100.0%	84.6%	0.0%	84.7%	0.0%	0.0%	85.7%	83.9%	100.0%	0.0%	90.8%	0.0%	0.0%	100.0%	100.0%	0.0%	100.0%	0.0%	0.0%	0.0%	91.6%	0.0%
Trucks	0	2	0	0	2	0	0	0	0	0	0	0	0	0	0	1	0	0	1	0	0	0	0	0	0	0	0	0	3	0.0%
% Trucks	0.0%	0.2%	0.0%	0.0%	0.2%	0.0%	0.0%	0.0%	0.0%	0.0%	0.0%	0.0%	0.0%	0.0%	0.0%	0.1%	0.0%	0.0%	0.1%	0.0%	0.0%	0.0%	0.0%	0.0%	0.0%	0.0%	0.0%	0.0%	0.1%	0.0%
Buses	0	60	25	0	85	0	0	19	0	6	0	25	0	0	4	54	0	0	58	0	0	0	0	0	0	0	0	0	168	0.0%
% Buses	0.0%	5.8%	13.5%	0.0%	0.0%	0.0%	0.0%	0.0%	0.0%	15.4%	0.0%	0.0%	0.0%	0.0%	14.3%	6.0%	0.0%	0.0%	0.0%	0.0%	0.0%	0.0%	0.0%	0.0%	0.0%	0.0%	0.0%	0.0%	6.8%	0.0%
Pedestrians	0	0	0	0	0	11	21	0	0	0	0	0	38	14	0	0	0	0	0	6	9	0	0	0	0	0	31	40	0	0.0%
% Pedestrians	0.0%	0.0%	0.0%	0.0%	0.0%	100.0%	85.5%	0.0%	0.0%	0.0%	0.0%	0.0%	100.0%	100.0%	0.0%	0.0%	0.0%	0.0%	0.0%	100.0%	100.0%	0.0%	0.0%	0.0%	0.0%	0.0%	0.0%	97.8%	0.0%	0.0%
Bicycles on Crosswalk	0	0	0	0	0	0	1	0	0	0	0	0	0	0	0	0	0	0	0	0	0	0	0	0	0	0	0	1	0	0.0%
% Bicycles on Crosswalk	0.0%	0.0%	0.0%	0.0%	0.0%	0.0%	4.5%	0.0%	0.0%	0.0%	0.0%	0.0%	0.0%	0.0%	0.0%	0.0%	0.0%	0.0%	0.0%	0.0%	0.0%	0.0%	0.0%	0.0%	0.0%	0.0%	0.0%	2.4%	0.0%	0.0%

Project : VBH Malta NY
 Site : Site 4
 Location : 42.948550, -73.790036
 Survey Date : 2021-04-28, Wednesday

Turning Movement Data Plot

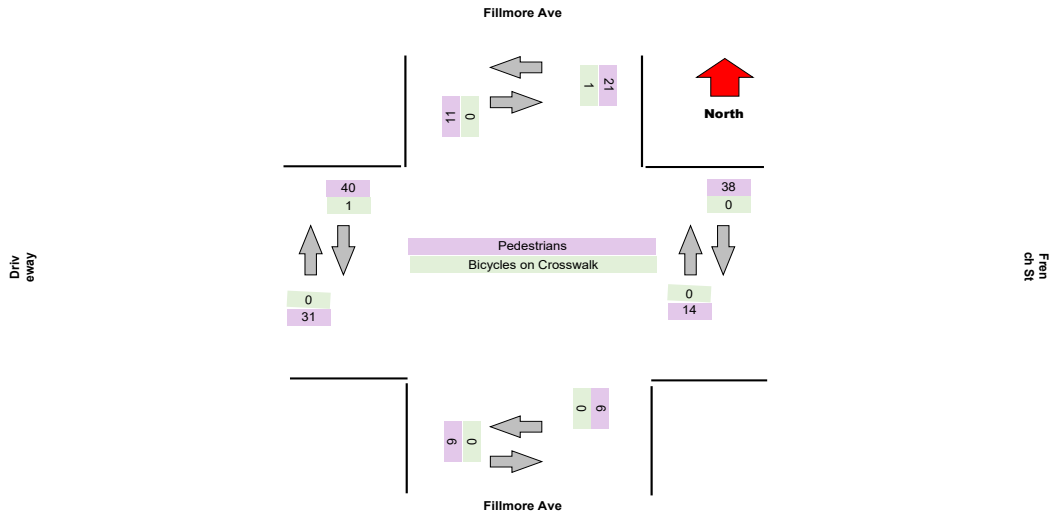
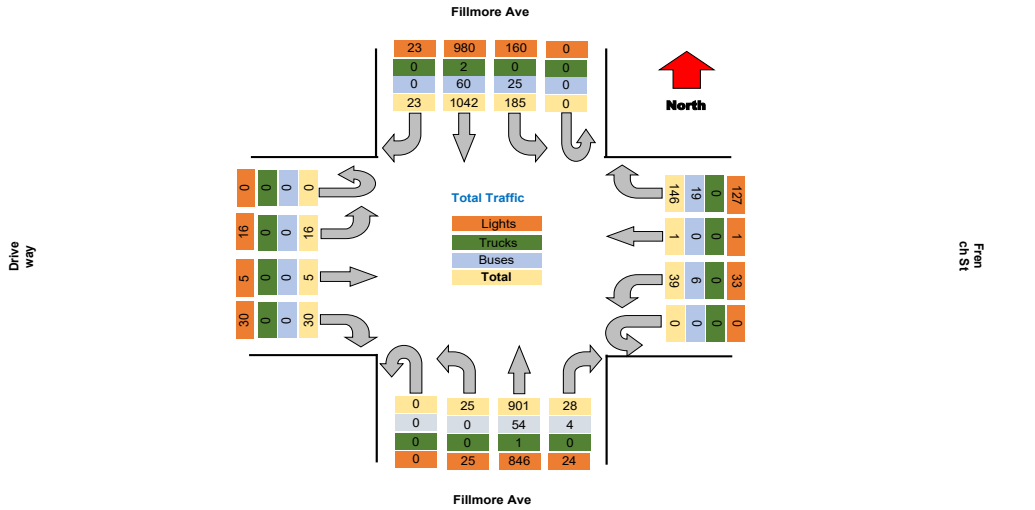

Project : VBH Malta NY
Site : Site 4
Location : 42.948550, -73.790036

TSTData.com

Survey Date : 2021-04-28, Wednesday

Turning Movement Peak Hour Data (AM)

7:30:00 AM

Leg Direction	Fillmore Ave Southbound					French St Westbound					Fillmore Ave Northbound					Driveway Eastbound					Total			
	Right	Thru	Left	U-Turn	App Total	Peds CW	Peds CCW	Right	Thru	Left	U-Turn	App Total	Peds CW	Peds CCW	Right	Thru	Left	U-Turn	App Total	Peds CW		Peds CCW		
7:30:00 AM	0	65	9	0	74	2	0	9	0	2	0	11	8	2	1	36	0	0	47	0	1	1	133	
7:45:00 AM	0	71	10	0	81	2	2	8	0	3	0	13	12	0	0	47	0	0	59	0	0	1	153	
8:00:00 AM	0	83	13	0	96	1	1	4	0	4	0	9	4	1	1	46	0	0	52	0	0	1	157	
8:15:00 AM	0	75	7	0	82	0	0	11	0	2	0	13	0	0	1	59	0	0	61	0	0	1	157	
Grand Total	0	294	39	0	333	3	3	32	0	11	0	45	25	3	3	195	0	0	219	0	1	5	600	
% Approach	0.0%	88.3%	11.7%	0.0%	0.0%	0.0%	0.0%	89.6%	0.0%	23.9%	0.0%	0.0%	0.0%	0.0%	1.4%	85.8%	0.0%	0.0%	0.0%	0.0%	50.0%	0.0%	0.0%	
% Total	0.0%	49.0%	6.5%	0.0%	55.5%	0.0%	0.0%	5.3%	0.0%	1.8%	0.0%	7.7%	0.0%	0.0%	0.5%	31.3%	0.0%	0.0%	36.5%	0.0%	0.0%	0.3%	0.0%	
PHF	0.000	0.886	0.750	0.000	0.867	0.000	0.000	0.727	0.000	0.688	0.000	0.885	0.000	0.000	0.750	0.797	0.000	0.898	0.000	0.000	0.250	0.250	0.955	
Lights	0	278	32	0	310	0	0	24	0	8	0	32	0	0	3	169	0	0	172	0	0	2	516	
% Lights	0.0%	94.6%	82.1%	0.0%	93.1%	0.0%	0.0%	75.0%	0.0%	72.7%	0.0%	69.6%	0.0%	0.0%	100.0%	89.0%	0.0%	0.0%	78.5%	0.0%	0.0%	100.0%	86.0%	
Trucks	0	0	0	0	0	0	0	0	0	0	0	0	0	0	0	0	0	0	0	0	0	0	0	
% Trucks	0.0%	0.0%	0.0%	0.0%	0.0%	0.0%	0.0%	0.0%	0.0%	0.0%	0.0%	0.0%	0.0%	0.0%	0.0%	0.0%	0.0%	0.0%	0.0%	0.0%	0.0%	0.0%	0.0%	
Buses	0	16	7	0	23	0	0	8	0	3	0	11	0	0	0	19	0	0	19	0	0	0	53	
% Buses	0.0%	5.4%	17.9%	0.0%	0.0%	0.0%	0.0%	25.0%	0.0%	27.3%	0.0%	0.0%	0.0%	0.0%	0.0%	10.1%	0.0%	0.0%	0.0%	0.0%	0.0%	0.0%	8.8%	
Pedestrians	0	0	0	0	0	3	2	0	0	0	0	0	25	3	0	0	0	1	0	0	0	4	4	
% Pedestrians	0.0%	0.0%	0.0%	0.0%	0.0%	100.0%	66.7%	0.0%	0.0%	0.0%	0.0%	0.0%	100.0%	100.0%	0.0%	0.0%	0.0%	0.0%	0.0%	0.0%	0.0%	100.0%	80.0%	0.0%
Bicycles on Crosswalk	0	0	0	0	0	0	1	0	0	0	0	0	0	0	0	0	0	0	0	0	0	0	1	
% Bicycles on Crosswalk	0.0%	0.0%	0.0%	0.0%	0.0%	0.0%	33.3%	0.0%	0.0%	0.0%	0.0%	0.0%	0.0%	0.0%	0.0%	0.0%	0.0%	0.0%	0.0%	0.0%	0.0%	0.0%	20.0%	

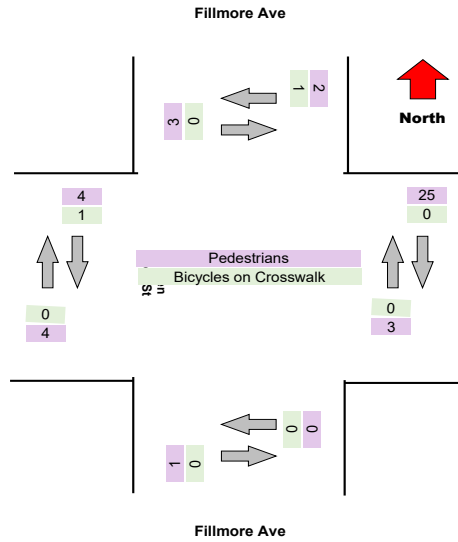
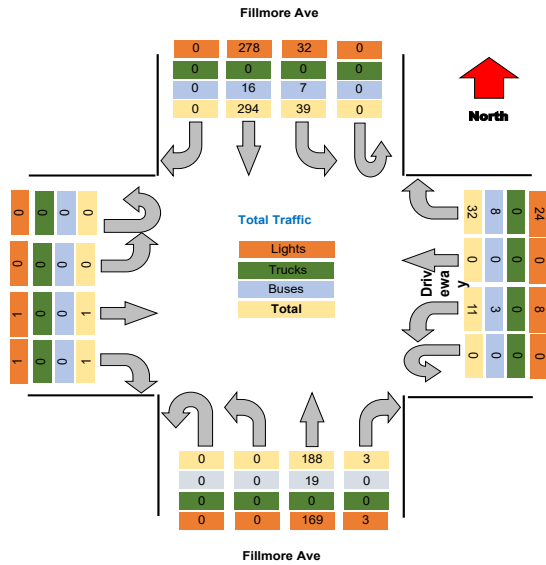

Turning Movement Peak Hour Data (PM)

4:45:00 PM

Leg Direction	Fillmore Ave					French St					Fillmore Ave					Driveway					Total							
	Southbound					Westbound					Northbound					Eastbound												
Start Time	Right	Thru	Left	U-Turn	App Total	Peds CW	Peds CCW	Right	Thru	Left	U-Turn	App Total	Peds CW	Peds CCW	Right	Thru	Left	U-Turn	App Total	Peds CW	Peds CCW	Right	Thru	Left	U-Turn	App Total	Peds CW	Peds CCW
4:45:00 PM	2	88	25	0	115	2	3	11	0	0	0	11	0	0	5	89	4	0	98	1	2	8	1	3	0	12	4	3
5:00:00 PM	4	78	22	0	104	3	4	15	0	3	0	18	3	1	3	87	5	0	95	1	1	2	0	0	2	5	7	
5:15:00 PM	3	80	11	0	94	1	1	19	0	1	0	20	0	1	2	78	6	0	86	0	0	2	1	2	0	5	0	
5:30:00 PM	1	70	13	0	84	0	0	9	0	7	0	16	0	0	1	68	1	0	70	0	0	3	0	2	0	5	0	
Grand Total	10	316	71	0	397	6	8	54	0	11	0	65	3	2	11	322	16	0	349	3	3	15	2	7	0	24	14	13
% Approach	2.5%	79.6%	17.9%	0.0%	0.0%	0.0%	0.0%	83.1%	0.0%	16.9%	0.0%	0.0%	0.0%	0.0%	3.2%	92.3%	4.6%	0.0%	0.0%	0.0%	0.0%	62.5%	8.3%	29.2%	0.0%	0.0%	0.0%	0.0%
% Total	1.2%	37.8%	8.5%	0.0%	47.5%	0.0%	0.0%	6.5%	0.0%	1.3%	0.0%	7.8%	0.0%	0.0%	1.3%	38.6%	1.9%	0.0%	41.8%	0.0%	0.0%	1.8%	0.2%	0.8%	0.0%	2.9%	0.0%	0.0%
PHF	0.625	0.898	0.710	0.000	0.863	0.000	0.000	0.711	0.000	0.393	0.000	0.813	0.000	0.000	0.550	0.904	0.667	0.000	0.890	0.000	0.000	0.469	0.500	0.583	0.000	0.500	0.000	0.000
Lights	10	305	66	0	381	0	0	50	0	11	0	61	0	0	10	314	16	0	340	0	0	15	2	7	0	24	0	
% Lights	100.0%	96.5%	93.0%	0.0%	96.0%	0.0%	0.0%	92.6%	0.0%	100.0%	0.0%	93.8%	0.0%	0.0%	80.9%	97.6%	100.0%	0.0%	97.4%	0.0%	0.0%	100.0%	100.0%	100.0%	0.0%	100.0%	0.0%	0.0%
Trucks	0	2	0	0	2	0	0	0	0	0	0	0	0	0	0	1	0	0	1	0	0	0	0	0	0	0	0	0
% Trucks	0.0%	0.6%	0.0%	0.0%	0.5%	0.0%	0.0%	0.0%	0.0%	0.0%	0.0%	0.0%	0.0%	0.0%	0.0%	0.3%	0.0%	0.0%	0.3%	0.0%	0.0%	0.0%	0.0%	0.0%	0.0%	0.0%	0.0%	0.0%
Buses	0	9	5	0	14	0	0	4	0	0	0	4	0	0	1	7	0	0	8	0	0	0	0	0	0	0	0	
% Buses	0.0%	2.8%	7.0%	0.0%	0.0%	0.0%	0.0%	7.4%	0.0%	0.0%	0.0%	0.0%	0.0%	0.0%	9.1%	2.2%	0.0%	0.0%	0.0%	0.0%	0.0%	0.0%	0.0%	0.0%	0.0%	0.0%	0.0%	
Pedestrians	0	0	0	0	0	6	5	0	0	0	0	0	9	2	0	0	0	0	0	3	0	0	0	0	0	0	14	13
% Pedestrians	0.0%	0.0%	0.0%	0.0%	0.0%	100.0%	100.0%	0.0%	0.0%	0.0%	0.0%	0.0%	100.0%	100.0%	0.0%	0.0%	0.0%	0.0%	0.0%	0.0%	100.0%	100.0%	0.0%	0.0%	0.0%	0.0%	100.0%	100.0%
Bicycles on Crosswalk	0	0	0	0	0	0	0	0	0	0	0	0	0	0	0	0	0	0	0	0	0	0	0	0	0	0	0	0
% Bicycles on Crosswalk	0.0%	0.0%	0.0%	0.0%	0.0%	0.0%	0.0%	0.0%	0.0%	0.0%	0.0%	0.0%	0.0%	0.0%	0.0%	0.0%	0.0%	0.0%	0.0%	0.0%	0.0%	0.0%	0.0%	0.0%	0.0%	0.0%	0.0%	0.0%

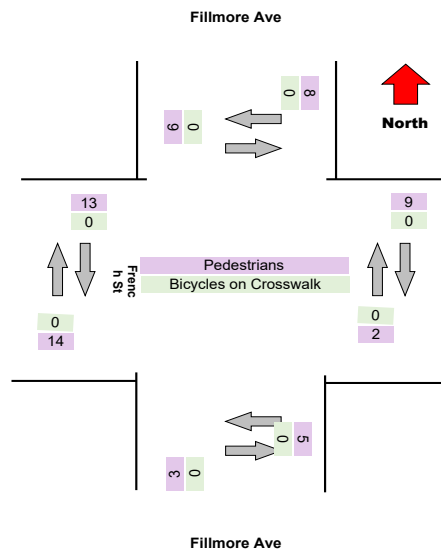
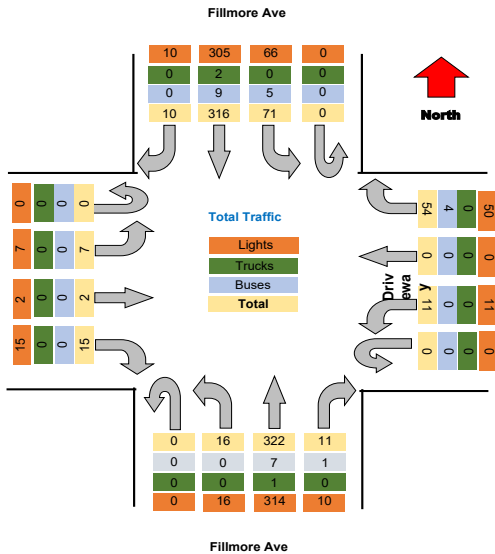

Project	LaBella
Project Code	LaBella
Site Name	23
Legs and Movements	All Processed Legs & Movements
Bin Size	15 minutes
Survey Date	2021-11-02, Tuesday
Location	23
Latitude and Longitude	42.910946, -78.839079

	Start	End	PHF
Forced Peak AM	2021/11/02 07:30:00	2021/11/02 08:30:00	0.927
Forced Peak PM	2021/11/02 16:30:00	2021/11/02 17:30:00	0.929
AM Peak	2021/11/02 07:30:00	2021/11/02 08:30:00	0.927
PM Peak	2021/11/02 16:30:00	2021/11/02 17:30:00	0.929

Turning Movement Data

Leg Direction	Fillmore Ave Southbound						Fillmore Ave NorthBound						E Utica St Eastbound										
	Right	Thru	U-Turn	App Total	Peds	CW	Peds	CCW	Thru	Left	U-Turn	App Total	Peds	CW	Peds	CCW	Right	Left	U-Turn	App Total	Peds	CW	
Start Time	12	23	0	35	0	0	15	1	0	16	0	0	7	3	0	10	0	0	0	0	0	0	
6:30:00 AM	3	21	0	24	0	0	23	9	0	32	0	0	10	5	0	15	1	0	0	0	0	0	
6:45:00 AM	15	44	0	59	0	0	38	10	0	48	0	0	17	8	0	25	1	0	0	0	0	0	
Hourly Total	15	44	0	59	0	0	38	10	0	48	0	0	17	8	0	25	1	0	0	0	0	0	
7:00:00 AM	5	23	0	28	0	0	25	7	0	32	0	0	9	8	0	17	0	0	0	0	0	0	
7:15:00 AM	9	21	0	30	0	1	29	6	0	36	0	0	12	4	0	16	0	0	0	0	0	0	
7:30:00 AM	10	26	0	36	0	0	33	9	0	42	0	0	12	1	0	13	1	0	0	0	0	0	
7:45:00 AM	9	38	0	47	0	0	30	6	0	36	0	0	18	5	0	23	0	0	0	0	0	0	
Hourly Total	33	108	0	141	0	1	117	28	0	146	0	0	51	18	0	69	1	0	0	0	0	0	
8:00:00 AM	6	38	0	44	0	0	26	7	0	33	0	0	24	9	0	33	1	0	0	0	0	0	
8:15:00 AM	7	41	0	48	0	0	33	4	0	37	0	0	12	4	0	16	0	0	0	0	0	0	
Hourly Total	13	79	0	92	0	0	59	11	0	70	0	0	36	13	0	49	1	0	0	0	0	0	
4:00:00 PM	13	69	0	82	0	0	54	18	0	72	0	0	26	25	0	51	1	0	0	0	0	0	
4:15:00 PM	16	65	0	81	0	0	60	12	0	72	0	1	23	20	0	43	1	0	0	0	0	0	
4:30:00 PM	19	58	0	77	0	0	64	13	0	77	0	0	14	10	0	24	0	0	0	0	0	0	
4:45:00 PM	20	56	0	76	0	0	74	12	0	86	0	1	25	13	0	38	1	0	0	0	0	0	
Hourly Total	68	248	0	316	0	0	252	55	0	307	0	2	88	68	0	156	3	0	0	0	0	0	
5:00:00 PM	25	74	0	99	0	1	68	11	0	79	1	0	23	15	0	38	0	0	0	0	0	0	
5:15:00 PM	18	52	0	70	0	0	76	15	0	91	0	0	30	18	0	48	0	0	0	0	0	0	
5:30:00 PM	19	57	0	76	0	0	61	11	0	72	0	0	23	14	0	37	2	0	0	0	0	0	
5:45:00 PM	17	51	0	68	0	1	48	11	0	59	0	1	28	15	0	43	1	0	0	0	0	0	
Hourly Total	79	234	0	313	0	1	253	48	0	301	1	1	104	62	0	166	3	0	0	0	0	0	
Grand Total	208	713	0	921	0	2	719	152	0	872	1	3	296	169	0	465	9	0	0	0	0	0	
% Approach	22.6%	77.4%	0.0%	0.0%	0.0%	0.0%	82.5%	17.4%	0.0%	0.0%	0.0%	0.0%	63.7%	36.3%	0.0%	0.0%	0.0%	0.0%	0.0%	0.0%	0.0%	0.0%	0.0%
% Total	9.2%	31.6%	0.0%	40.8%	0.0%	0.0%	31.8%	6.7%	0.0%	38.6%	0.0%	0.0%	13.1%	7.5%	0.0%	20.6%	0.0%	0.0%	0.0%	0.0%	0.0%	0.0%	0.0%
Lights	207	684	0	891	0	0	697	135	0	832	0	0	281	169	0	450	0	0	0	0	0	0	0
% Lights	99.5%	95.9%	0.0%	96.7%	0.0%	0.0%	96.9%	88.8%	0.0%	95.4%	0.0%	0.0%	94.9%	100.0%	0.0%	96.8%	0.0%	0.0%	0.0%	0.0%	0.0%	0.0%	0.0%
Trucks	0	2	0	2	0	0	2	0	0	2	0	0	0	0	0	0	0	0	0	0	0	0	0
% Trucks	0.0%	0.3%	0.0%	0.2%	0.0%	0.0%	0.3%	0.0%	0.0%	0.2%	0.0%	0.0%	0.0%	0.0%	0.0%	0.0%	0.0%	0.0%	0.0%	0.0%	0.0%	0.0%	0.0%
Buses	1	26	0	27	0	0	19	17	0	36	0	0	15	0	0	15	0	0	0	0	0	0	0
% Buses	0.5%	3.6%	0.0%	0.0%	0.0%	0.0%	0.0%	11.2%	0.0%	0.0%	0.0%	0.0%	5.1%	0.0%	0.0%	0.0%	0.0%	0.0%	0.0%	0.0%	0.0%	0.0%	0.0%
Pedestrians	0	0	0	0	0	2	0	0	0	0	1	3	0	0	0	0	9	0	0	0	0	0	0
% Pedestrians	0.0%	0.0%	0.0%	0.0%	0.0%	100.0%	0.0%	0.0%	0.0%	0.0%	100.0%	100.0%	0.0%	0.0%	0.0%	0.0%	100.0%	0.0%	0.0%	0.0%	0.0%	100.0%	0.0%
Bicycles on Crosswalk	0	0	0	0	0	0	0	0	0	0	0	0	0	0	0	0	0	0	0	0	0	0	0
% Bicycles on Crosswalk	0.0%	0.0%	0.0%	0.0%	0.0%	0.0%	0.0%	0.0%	0.0%	0.0%	0.0%	0.0%	0.0%	0.0%	0.0%	0.0%	0.0%	0.0%	0.0%	0.0%	0.0%	0.0%	0.0%

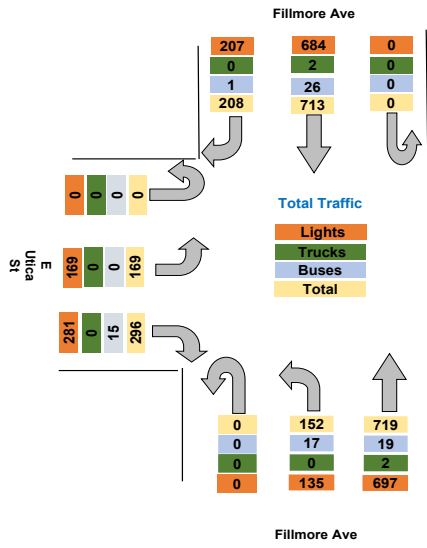

Turning Movement Data Plot

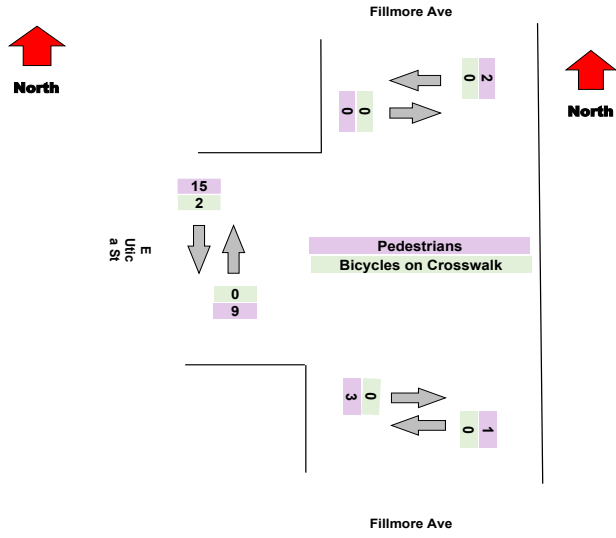

Turning Movement Peak Hour Data (AM)

7:30:00 AM

Leg Direction	Fillmore Ave Southbound						Fillmore Ave NorthBound						E Utica St Eastbound				
	Right	Thru	U-Turn	App Total	Peds CW	Peds CCW	Thru	Left	U-Turn	App Total	Peds CW	Peds CCW	Right	Left	U-Turn	App Total	Peds CW
7:30:00 AM	10	26	0	36	0	0	33	9	0	42	0	0	12	1	0	13	1
7:45:00 AM	9	38	0	47	0	0	30	6	0	36	0	0	18	5	0	23	0
8:00:00 AM	6	38	0	44	0	0	26	7	0	33	0	0	24	9	0	33	1
8:15:00 AM	7	41	0	48	0	0	33	4	0	37	0	0	12	4	0	16	0
Grand Total	32	143	0	175	0	0	122	26	0	148	0	0	66	19	0	85	2
% Approach	18.3%	81.7%	0.0%	0.0%	0.0%	0.0%	82.4%	17.6%	0.0%	0.0%	0.0%	0.0%	77.6%	22.4%	0.0%	0.0%	0.0%
% Total	7.8%	35.0%	0.0%	42.9%	0.0%	0.0%	29.9%	6.4%	0.0%	36.3%	0.0%	0.0%	16.2%	4.7%	0.0%	20.8%	0.0%
PHF	0.800	0.872	0.000	0.911	0.000	0.000	0.924	0.722	0.000	0.881	0.000	0.000	0.688	0.528	0.000	0.644	0.000
Lights	32	135	0	167	0	0	115	20	0	135	0	0	62	19	0	81	0
% Lights	100.0%	94.4%	0.0%	95.4%	0.0%	0.0%	94.3%	76.9%	0.0%	91.2%	0.0%	0.0%	93.9%	100.0%	0.0%	95.3%	0.0%
Trucks	0	0	0	0	0	0	0	0	0	0	0	0	0	0	0	0	0
% Trucks	0.0%	0.0%	0.0%	0.0%	0.0%	0.0%	0.0%	0.0%	0.0%	0.0%	0.0%	0.0%	0.0%	0.0%	0.0%	0.0%	0.0%
Buses	0	8	0	8	0	0	7	6	0	13	0	0	4	0	0	4	0
% Buses	0.0%	5.6%	0.0%	0.0%	0.0%	0.0%	5.7%	23.1%	0.0%	0.0%	0.0%	0.0%	6.1%	0.0%	0.0%	0.0%	0.0%
Pedestrians	0	0	0	0	0	0	0	0	0	0	0	0	0	0	0	0	2
% Pedestrians	0.0%	0.0%	0.0%	0.0%	0.0%	0.0%	0.0%	0.0%	0.0%	0.0%	0.0%	0.0%	0.0%	0.0%	0.0%	0.0%	100.0%
Bicycles on Crosswalk	0	0	0	0	0	0	0	0	0	0	0	0	0	0	0	0	0
% Bicycles on Crosswalk	0.0%	0.0%	0.0%	0.0%	0.0%	0.0%	0.0%	0.0%	0.0%	0.0%	0.0%	0.0%	0.0%	0.0%	0.0%	0.0%	0.0%

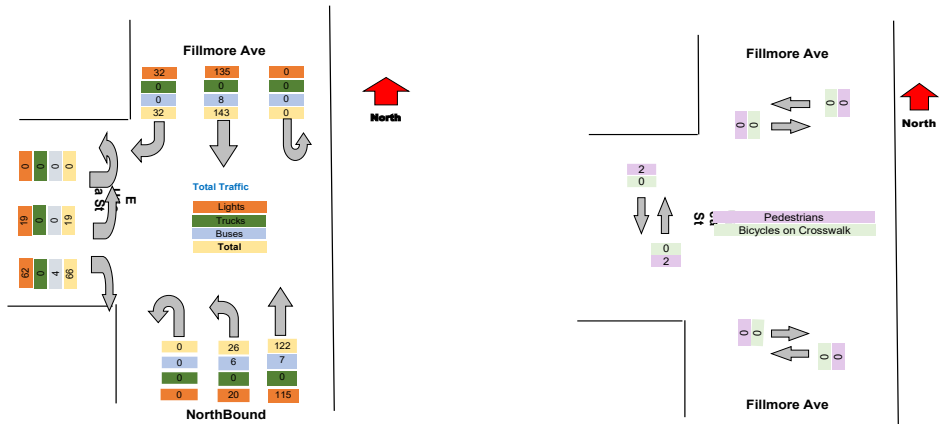

Turning Movement Peak Hour Data (PM)

4:30:00 PM

Leg Direction	Fillmore Ave Southbound						Fillmore Ave NorthBound						E Utica St Eastbound					
	Right	Thru	U-Turn	App Total	Peds CW	Peds CCW	Thru	Left	U-Turn	App Total	Peds CW	Peds CCW	Right	Left	U-Turn	App Total	Peds CW	
4:30:00 PM	19	58	0	77	0	0	64	13	0	77	0	0	14	10	0	24	0	
4:45:00 PM	20	56	0	76	0	0	74	12	0	86	0	1	25	13	0	38	1	
5:00:00 PM	25	74	0	99	0	1	68	11	0	79	1	0	23	15	0	38	0	
5:15:00 PM	18	52	0	70	0	0	76	15	0	91	0	0	30	18	0	48	0	
Grand Total	82	240	0	322	0	1	282	51	0	333	1	1	92	56	0	148	1	
% Approach	25.5%	74.5%	0.0%	0.0%	0.0%	0.0%	84.7%	15.3%	0.0%	0.0%	0.0%	0.0%	62.2%	37.8%	0.0%	0.0%	0.0%	
% Total	10.2%	29.9%	0.0%	40.1%	0.0%	0.0%	35.1%	6.4%	0.0%	41.5%	0.0%	0.0%	11.5%	7.0%	0.0%	18.4%	0.0%	
PHF	0.820	0.811	0.000	0.813	0.000	0.000	0.928	0.850	0.000	0.915	0.000	0.000	0.767	0.778	0.000	0.771	0.000	
Lights	81	229	0	310	0	0	276	48	0	324	0	0	88	56	0	144	0	
% Lights	98.8%	95.4%	0.0%	96.3%	0.0%	0.0%	97.9%	94.1%	0.0%	97.3%	0.0%	0.0%	95.7%	100.0%	0.0%	97.3%	0.0%	
Trucks	0	2	0	2	0	0	2	0	0	2	0	0	0	0	0	0	0	
% Trucks	0.0%	0.8%	0.0%	0.6%	0.0%	0.0%	0.7%	0.0%	0.0%	0.6%	0.0%	0.0%	0.0%	0.0%	0.0%	0.0%	0.0%	
Buses	1	8	0	9	0	0	3	3	0	6	0	0	4	0	0	4	0	
% Buses	1.2%	3.3%	0.0%	0.0%	0.0%	0.0%	1.1%	5.9%	0.0%	0.0%	0.0%	0.0%	4.3%	0.0%	0.0%	0.0%	0.0%	
Pedestrians	0	0	0	0	0	1	0	0	0	1	1	1	0	0	0	0	1	
% Pedestrians	0.0%	0.0%	0.0%	0.0%	0.0%	100.0%	0.0%	0.0%	0.0%	0.0%	100.0%	100.0%	0.0%	0.0%	0.0%	0.0%	100.0%	
Bicycles on Crosswalk	0	0	0	0	0	0	0	0	0	0	0	0	0	0	0	0	0	
% Bicycles on Crosswalk	0.0%	0.0%	0.0%	0.0%	0.0%	0.0%	0.0%	0.0%	0.0%	0.0%	0.0%	0.0%	0.0%	0.0%	0.0%	0.0%	0.0%	

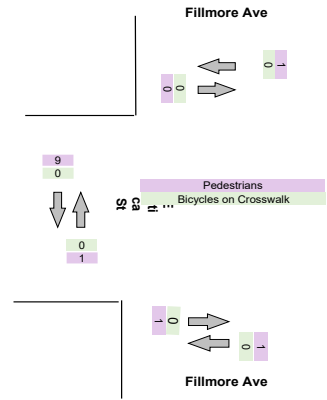
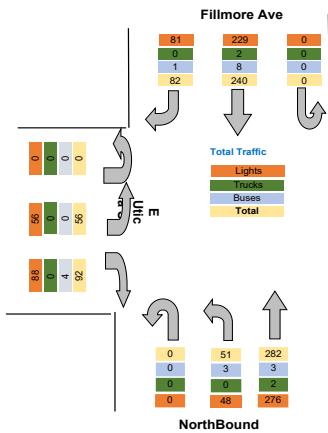

Intersection: Elm St Pine St
 Location: Kennett Square, PA
 Site: 01
 Survey Date: Wednesday, 04-28-2021
 GPS: 42.948550, -72.790034

Peds CCW	Total
0	61
0	71
0	132
0	77
0	82
0	91
0	106
0	356
2	110
0	101
2	211
3	205
1	196
1	178
4	200
9	779
0	216
4	209
1	185
1	170
6	780
17	2258
0.0%	0.0%
0.0%	0.0%
0	2173
0.0%	96.2%
0	4
0.0%	0.2%
0	76
0.0%	3.5%
15	0
88.2%	0.0%
2	0
11.8%	0.0%

Intersection: Elm St Pine St
 Location: Kennett Square, PA
 Site: 01
 Survey Date: Wednesday, 04-28-2021
 GPS: 42.948550, -72.790034



Peds CCW	Total
0	91
0	106
2	110
0	101
2	408
0.0%	
0.0%	
0.000	0.927
0	383
0.0%	93.9%
0	0
0.0%	0.0%
0	25
0.0%	6.1%
2	0
100.0%	0.0%
0	0
0.0%	0.0%

Intersection: Elm St Pine St
 Location: Kennett Square, PA
 Site: 01
 Survey Date: Wednesday, 04-28-2021
 GPS: 42.948550, -72.790034



Peds CCW	Total
1	178
4	200
0	216
4	209
9	803
0.0%	
0.0%	
0.000	0.929
0	778
0.0%	96.9%
0	4
0.0%	0.5%
0	19
0.0%	2.4%
9	0
100.0%	0.0%
0	0
0.0%	0.0%

Project	LaBella
Project Code	LaBella
Site Name	23
Legs and Movements	All Processed Legs & Movements
Bin Size	15 minutes
Survey Date	2021-11-03, Wednesday
Location	23
Latitude and Longitude	42.910946, -78.839079

	Start	End	PHF
Forced Peak AM	2021/11/03 07:30:00	2021/11/03 08:30:00	0.843
Forced Peak PM	2021/11/03 16:30:00	2021/11/03 17:30:00	0.904
AM Peak	2021/11/03 07:30:00	2021/11/03 08:30:00	0.843
PM Peak	2021/11/03 16:30:00	2021/11/03 17:30:00	0.904

Turning Movement Data

Leg Direction	Fillmore Ave Southbound					Fillmore Ave NorthBound					E Utica St Eastbound				
	Right	Thru	U-Turn	App Total	Peds CW Peds CCW	Thru	Left	U-Turn	App Total	Peds CW Peds CCW	Right	Left	U-Turn	App Total	Peds CW
Start Time															
6:30:00 AM	9	22	0	31	0 0	21	3	0	24	0 0	8	3	0	11	0
6:45:00 AM	6	26	0	32	0 0	31	5	0	36	0 0	15	6	0	21	0
Hourly Total	15	48	0	63	0 0	52	8	0	60	0 0	23	9	0	32	0
7:00:00 AM	9	31	0	40	0 0	26	9	0	35	0 0	15	9	0	24	3
7:15:00 AM	8	39	0	47	0 0	30	6	0	36	0 0	10	5	0	15	0
7:30:00 AM	18	48	0	66	0 0	36	6	0	42	0 0	19	8	0	27	2
7:45:00 AM	18	74	0	92	1 1	59	13	0	73	1 0	22	9	0	32	1
Hourly Total	53	192	0	245	1 1	151	34	0	186	1 0	66	31	0	98	6
8:00:00 AM	20	58	0	78	0 0	48	8	0	56	0 0	20	13	0	33	0
8:15:00 AM	13	64	0	77	0 0	52	9	0	61	2 0	13	12	0	27	0
Hourly Total	33	122	0	155	0 0	100	17	0	117	2 0	33	25	0	60	0
4:00:00 PM	19	63	0	82	0 0	68	14	0	82	1 2	27	27	0	54	11
4:15:00 PM	21	80	0	101	1 0	74	20	0	94	0 0	23	25	0	48	1
4:30:00 PM	19	85	0	104	0 0	57	16	0	73	0 0	42	26	0	68	6
4:45:00 PM	13	70	0	83	0 1	79	18	0	97	0 0	23	30	0	53	3
Hourly Total	72	298	0	370	1 1	278	68	0	346	1 2	115	108	0	223	21
5:00:00 PM	14	65	0	79	0 0	71	4	0	75	0 2	23	17	0	40	1
5:15:00 PM	8	72	0	80	0 0	69	11	0	80	1 0	35	19	0	54	2
5:30:00 PM	23	62	0	85	1 0	72	16	0	88	0 0	23	12	0	35	3
5:45:00 PM	10	53	0	63	0 0	55	11	0	66	0 0	26	10	0	36	1
Hourly Total	55	252	0	307	1 0	267	42	0	309	1 2	107	58	0	165	7
Grand Total	228	912	0	1140	3 2	848	169	0	1018	5 4	344	231	0	578	34
% Approach	20.0%	80.0%	0.0%	0.0%	0.0%	83.3%	16.6%	0.0%	0.0%	0.0%	59.5%	40.0%	0.0%	0.0%	0.0%
% Total	8.3%	33.3%	0.0%	41.7%	0.0%	31.0%	6.2%	0.0%	37.2%	0.0%	12.6%	8.4%	0.0%	21.1%	0.0%
Lights	223	847	0	1070	0 0	786	147	0	933	0 0	314	221	0	535	0
% Lights	97.8%	92.9%	0.0%	93.9%	0.0%	92.7%	87.0%	0.0%	91.7%	0.0%	91.3%	95.7%	0.0%	92.6%	0.0%
Trucks	0	2	0	2	0 0	2	0	0	2	0 0	1	0	0	1	0
% Trucks	0.0%	0.2%	0.0%	0.2%	0.0%	0.2%	0.0%	0.0%	0.2%	0.0%	0.3%	0.0%	0.0%	0.2%	0.0%
Buses	5	63	0	68	0 0	60	22	0	82	0 0	29	10	0	39	0
% Buses	2.2%	6.9%	0.0%	0.0%	0.0%	0.0%	13.0%	0.0%	0.0%	0.0%	8.4%	4.3%	0.0%	0.0%	0.0%
Pedestrians	0	0	0	0	3 2	0	0	0	0	5 4	0	0	0	0	34
% Pedestrians	0.0%	0.0%	0.0%	0.0%	100.0%	0.0%	0.0%	0.0%	0.0%	100.0%	0.0%	0.0%	0.0%	0.0%	100.0%
Bicycles on Crosswalk	0	0	0	0	0 0	0	0	0	0	0 0	0	0	0	0	0
% Bicycles on Crosswalk	0.0%	0.0%	0.0%	0.0%	0.0%	0.0%	0.0%	0.0%	0.0%	0.0%	0.0%	0.0%	0.0%	0.0%	0.0%

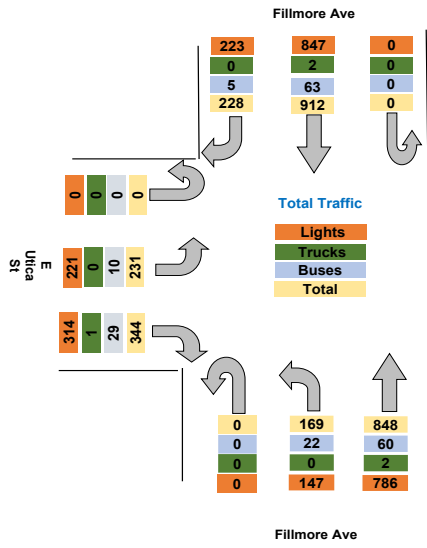

Turning Movement Data Plot

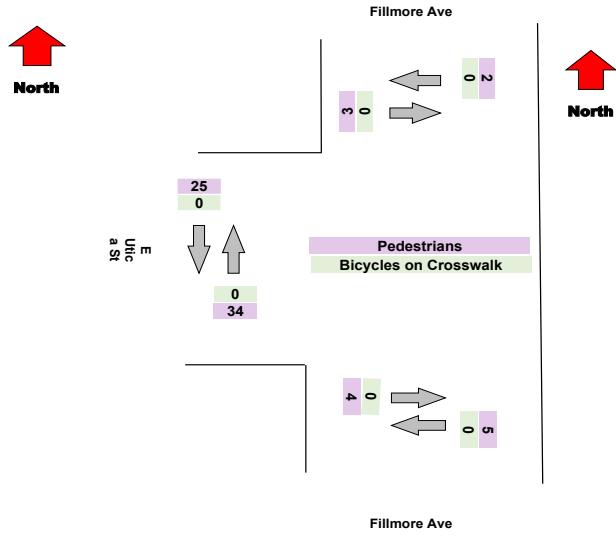

Turning Movement Peak Hour Data (AM)

7:30:00 AM

Leg Direction	Fillmore Ave Southbound						Fillmore Ave NorthBound						E Utica St Eastbound				
	Right	Thru	U-Turn	App Total	Peds CW	Peds CCW	Thru	Left	U-Turn	App Total	Peds CW	Peds CCW	Right	Left	U-Turn	App Total	Peds CW
7:30:00 AM	18	48	0	66	0	0	36	6	0	42	0	0	19	8	0	27	2
7:45:00 AM	18	74	0	92	1	1	59	13	0	73	1	0	22	9	0	32	1
8:00:00 AM	20	58	0	78	0	0	48	8	0	56	0	0	20	13	0	33	0
8:15:00 AM	13	64	0	77	0	0	52	9	0	61	2	0	13	12	0	27	0
Grand Total	69	244	0	313	1	1	195	36	0	232	3	0	74	42	0	119	3
% Approach	22.0%	78.0%	0.0%	0.0%	0.0%	0.0%	84.1%	15.5%	0.0%	0.0%	0.0%	0.0%	62.2%	35.3%	0.0%	0.0%	0.0%
% Total	10.4%	36.7%	0.0%	47.1%	0.0%	0.0%	29.4%	5.4%	0.0%	34.9%	0.0%	0.0%	11.1%	6.3%	0.0%	17.9%	0.0%
PHF	0.863	0.824	0.000	0.851	0.000	0.000	0.826	0.692	0.000	0.795	0.000	0.000	0.841	0.808	0.000	0.902	0.000
Lights	66	226	0	292	0	0	171	28	0	199	0	0	69	39	0	108	0
% Lights	95.7%	92.6%	0.0%	93.3%	0.0%	0.0%	87.7%	77.8%	0.0%	85.8%	0.0%	0.0%	93.2%	92.9%	0.0%	90.8%	0.0%
Trucks	0	0	0	0	0	0	0	0	0	0	0	0	0	0	0	0	0
% Trucks	0.0%	0.0%	0.0%	0.0%	0.0%	0.0%	0.0%	0.0%	0.0%	0.0%	0.0%	0.0%	0.0%	0.0%	0.0%	0.0%	0.0%
Buses	3	18	0	21	0	0	24	8	0	32	0	0	5	3	0	8	0
% Buses	4.3%	7.4%	0.0%	0.0%	0.0%	0.0%	12.3%	22.2%	0.0%	0.0%	0.0%	0.0%	6.8%	7.1%	0.0%	0.0%	0.0%
Pedestrians	0	0	0	0	1	1	0	0	0	3	0	0	0	0	0	0	3
% Pedestrians	0.0%	0.0%	0.0%	0.0%	100.0%	100.0%	0.0%	0.0%	0.0%	0.0%	100.0%	0.0%	0.0%	0.0%	0.0%	0.0%	100.0%
Bicycles on Crosswalk	0	0	0	0	0	0	0	0	0	0	0	0	0	0	0	0	0
% Bicycles on Crosswalk	0.0%	0.0%	0.0%	0.0%	0.0%	0.0%	0.0%	0.0%	0.0%	0.0%	0.0%	0.0%	0.0%	0.0%	0.0%	0.0%	0.0%

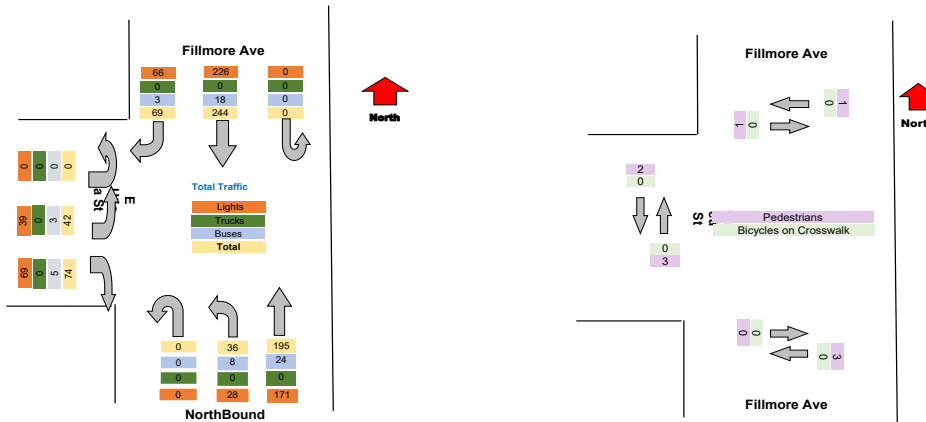

Turning Movement Peak Hour Data (PM)

4:30:00 PM

Leg Direction	Fillmore Ave Southbound						Fillmore Ave NorthBound						E Utica St Eastbound				
	Right	Thru	U-Turn	App Total	Peds CW	Peds CCW	Thru	Left	U-Turn	App Total	Peds CW	Peds CCW	Right	Left	U-Turn	App Total	Peds CW
4:30:00 PM	19	85	0	104	0	0	57	16	0	73	0	0	42	26	0	68	6
4:45:00 PM	13	70	0	83	0	1	79	18	0	97	0	0	23	30	0	53	3
5:00:00 PM	14	65	0	79	0	0	71	4	0	75	0	2	23	17	0	40	1
5:15:00 PM	8	72	0	80	0	0	69	11	0	80	1	0	35	19	0	54	2
Grand Total	54	292	0	346	0	1	276	49	0	325	1	2	123	92	0	215	12
% Approach	15.6%	84.4%	0.0%	0.0%	0.0%	0.0%	84.9%	15.1%	0.0%	0.0%	0.0%	0.0%	57.2%	42.8%	0.0%	0.0%	0.0%
% Total	6.1%	33.0%	0.0%	39.1%	0.0%	0.0%	31.2%	5.5%	0.0%	36.7%	0.0%	0.0%	13.9%	10.4%	0.0%	24.3%	0.0%
PHF	0.711	0.859	0.000	0.832	0.000	0.000	0.873	0.681	0.000	0.838	0.000	0.000	0.732	0.767	0.000	0.790	0.000
Lights	52	276	0	328	0	0	264	45	0	309	0	0	114	91	0	205	0
% Lights	96.3%	94.5%	0.0%	94.8%	0.0%	0.0%	95.7%	91.8%	0.0%	95.1%	0.0%	0.0%	92.7%	98.9%	0.0%	95.3%	0.0%
Trucks	0	1	0	1	0	0	1	0	0	1	0	0	0	0	0	0	0
% Trucks	0.0%	0.3%	0.0%	0.3%	0.0%	0.0%	0.4%	0.0%	0.0%	0.3%	0.0%	0.0%	0.0%	0.0%	0.0%	0.0%	0.0%
Buses	2	15	0	17	0	0	11	4	0	15	0	0	9	1	0	10	0
% Buses	3.7%	5.1%	0.0%	0.0%	0.0%	0.0%	4.0%	8.2%	0.0%	0.0%	0.0%	0.0%	7.3%	1.1%	0.0%	0.0%	0.0%
Pedestrians	0	0	0	0	0	1	0	0	0	1	2	0	0	0	0	0	12
% Pedestrians	0.0%	0.0%	0.0%	0.0%	0.0%	100.0%	0.0%	0.0%	0.0%	0.0%	100.0%	100.0%	0.0%	0.0%	0.0%	0.0%	100.0%
Bicycles on Crosswalk	0	0	0	0	0	0	0	0	0	0	0	0	0	0	0	0	0
% Bicycles on Crosswalk	0.0%	0.0%	0.0%	0.0%	0.0%	0.0%	0.0%	0.0%	0.0%	0.0%	0.0%	0.0%	0.0%	0.0%	0.0%	0.0%	0.0%

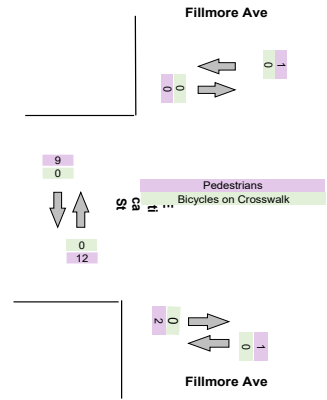
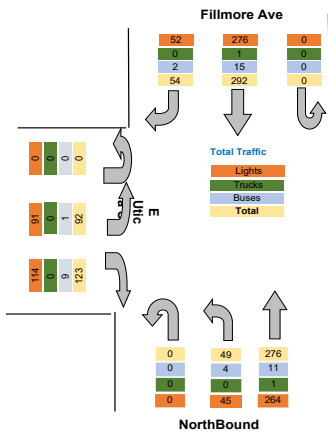

Intersection: Elm St Pine St
 Location: Kennett Square, PA
 Site: 01
 Survey Date: Wednesday, 04-28-2021
 GPS: 42.948550, -72.790034



Peds CCW	Total
0	66
0	89
0	155
0	99
2	98
1	135
0	197
3	529
0	167
1	165
1	332
5	218
5	243
0	245
4	233
14	939
2	194
3	214
1	208
1	165
7	781
25	2736
0.0%	0.0%
0.0%	0.0%
0	2538
0.0%	92.8%
0	5
0.0%	0.2%
0	169
0.0%	6.9%
25	0
100.0%	0.0%
0	0
0.0%	0.0%

Intersection: Elm St Pine St
 Location: Kennett Square, PA
 Site: 01
 Survey Date: Wednesday, 04-28-2021
 GPS: 42.948550, -72.790034



Peds CCW	Total
1	135
0	197
0	167
1	165
2	664
0.0%	
0.0%	
0.000	0.843
0	599
0.0%	90.2%
0	0
0.0%	0.0%
0	61
0.0%	9.2%
2	0
100.0%	0.0%
0	0
0.0%	0.0%

Intersection: Elm St Pine St
 Location: Kennett Square, PA
 Site: 01
 Survey Date: Wednesday, 04-28-2021
 GPS: 42.948550, -72.790034



Peds CCW	Total
0	245
4	233
2	194
3	214
9	886
0.0%	
0.0%	
0.000	0.904
0	842
0.0%	95.0%
0	2
0.0%	0.2%
0	42
0.0%	4.7%
9	0
100.0%	0.0%
0	0
0.0%	0.0%

Project	LaBella
Project Code	LaBella
Site Name	23
Legs and Movements	All Processed Legs & Movements
Bin Size	15 minutes
Survey Date	2021-11-04, Thursday
Location	23
Latitude and Longitude	42.910946, -78.839079

	Start	End	PHF
Forced Peak AM	2021/11/04 07:30:00	2021/11/04 08:30:00	0.921787709
Forced Peak PM	2021/11/04 16:30:00	2021/11/04 17:30:00	0.919960474
AM Peak	2021/11/04 07:30:00	2021/11/04 08:30:00	0.921787709
PM Peak	2021/11/04 16:30:00	2021/11/04 17:30:00	0.919960474

Turning Movement Data

Leg Direction	Fillmore Ave Southbound						Fillmore Ave Northbound						E Utica St Eastbound			
	Right	Thru	U-Turn	App Total	Peds CW	Peds CCW	Thru	Left	U-Turn	App Total	Peds CW	Peds CCW	Right	Left	U-Turn	App Total
Start Time																
6:30:00 AM	4	19	0	23	0	0	13	6	0	19	0	0	6	1	0	7
6:45:00 AM	11	29	0	40	0	0	25	5	0	30	1	0	8	6	0	15
Hourly Total	15	48	0	63	0	0	38	11	0	49	1	0	14	7	0	22
7:00:00 AM	10	33	0	43	0	0	29	6	0	35	0	0	9	11	0	20
7:15:00 AM	10	28	0	38	0	0	31	5	0	36	0	0	13	9	0	22
7:30:00 AM	14	55	0	69	0	0	33	10	0	43	0	0	20	17	0	37
7:45:00 AM	24	62	0	86	0	0	42	8	0	50	0	0	22	7	0	29
Hourly Total	58	178	0	236	0	0	135	29	0	164	0	0	64	44	0	108
8:00:00 AM	13	74	0	87	0	0	44	11	0	55	0	0	20	17	0	37
8:15:00 AM	11	69	0	80	0	0	56	9	0	65	0	0	14	8	0	22
Hourly Total	24	143	0	167	0	0	100	20	0	120	0	0	34	25	0	59
4:00:00 PM	19	72	0	91	0	0	79	14	0	93	1	0	23	19	0	42
4:15:00 PM	22	79	0	101	0	0	57	16	0	73	2	0	30	25	0	55
4:30:00 PM	18	59	0	77	0	0	88	10	0	98	0	0	24	20	0	44
4:45:00 PM	15	81	0	96	0	1	82	18	0	100	1	0	30	27	0	57
Hourly Total	74	291	0	365	0	1	306	58	0	364	4	0	107	91	0	198
5:00:00 PM	15	66	0	81	0	0	79	16	1	96	0	3	35	19	0	54
5:15:00 PM	10	73	0	83	0	0	79	21	0	100	1	1	23	22	0	45
5:30:00 PM	15	67	0	82	0	0	72	12	0	84	0	0	24	13	0	37
5:45:00 PM	15	75	0	90	0	0	56	23	0	79	0	0	21	10	0	31
Hourly Total	55	281	0	336	0	0	286	72	1	359	1	4	103	64	0	167
Grand Total	226	941	0	1167	0	1	865	190	1	1056	6	4	322	231	0	554
% Approach	19.4%	80.6%	0.0%	0.0%	0.0%	0.0%	81.9%	18.0%	0.1%	0.0%	0.0%	0.0%	58.1%	41.7%	0.0%	0.0%
% Total	8.1%	33.9%	0.0%	42.0%	0.0%	0.0%	31.1%	6.8%	0.0%	38.0%	0.0%	0.0%	11.6%	8.3%	0.0%	19.9%
Lights	220	883	0	1103	0	0	812	169	1	982	0	0	293	221	0	514
% Lights	97.3%	93.8%	0.0%	94.5%	0.0%	0.0%	93.9%	88.9%	100.0%	93.0%	0.0%	0.0%	91.0%	95.7%	0.0%	92.8%
Trucks	0	2	0	2	0	0	1	0	0	1	0	0	0	0	0	0
% Trucks	0.0%	0.2%	0.0%	0.2%	0.0%	0.0%	0.1%	0.0%	0.0%	0.1%	0.0%	0.0%	0.0%	0.0%	0.0%	0.0%
Buses	6	56	0	62	0	0	52	21	0	73	0	0	29	10	0	39
% Buses	2.7%	6.0%	0.0%	0.0%	0.0%	0.0%	0.0%	11.1%	0.0%	0.0%	0.0%	0.0%	9.0%	4.3%	0.0%	0.0%
Pedestrians	0	0	0	0	0	1	0	0	0	0	6	3	0	0	0	0
% Pedestrians	0.0%	0.0%	0.0%	0.0%	0.0%	100.0%	0.0%	0.0%	0.0%	0.0%	100.0%	75.0%	0.0%	0.0%	0.0%	0.0%
Bicycles on Crosswalk	0	0	0	0	0	0	0	0	0	0	0	1	0	0	0	0
% Bicycles on Crosswalk	0.0%	0.0%	0.0%	0.0%	0.0%	0.0%	0.0%	0.0%	0.0%	0.0%	0.0%	25.0%	0.0%	0.0%	0.0%	0.0%

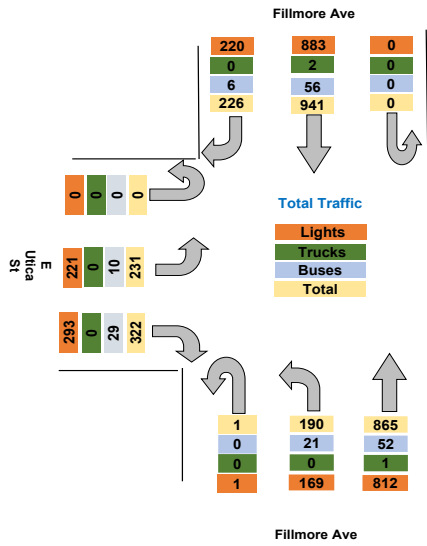

Turning Movement Data Plot

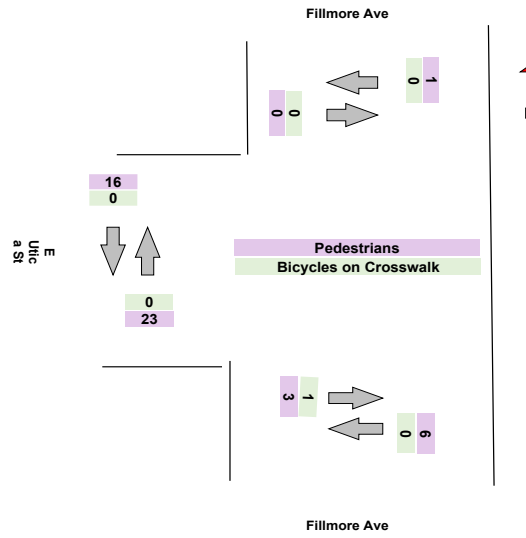

Turning Movement Peak Hour Data (AM)

7:30:00 AM

Leg Direction	Fillmore Ave Southbound						Fillmore Ave NorthBound						E Utica St Eastbound			
	Right	Thru	U-Turn	App Total	Peds CW	Peds CCW	Thru	Left	U-Turn	App Total	Peds CW	Peds CCW	Right	Left	U-Turn	App Total
7:30:00 AM	14	55	0	69	0	0	33	10	0	43	0	0	20	17	0	37
7:45:00 AM	24	62	0	86	0	0	42	8	0	50	0	0	22	7	0	29
8:00:00 AM	13	74	0	87	0	0	44	11	0	55	0	0	20	17	0	37
8:15:00 AM	11	69	0	80	0	0	56	9	0	65	0	0	14	8	0	22
Grand Total	62	260	0	322	0	0	175	38	0	213	0	0	76	49	0	125
% Approach	19.3%	80.7%	0.0%	0.0%	0.0%	0.0%	82.2%	17.8%	0.0%	0.0%	0.0%	0.0%	60.8%	39.2%	0.0%	0.0%
% Total	9.4%	39.4%	0.0%	48.8%	0.0%	0.0%	26.5%	5.8%	0.0%	32.3%	0.0%	0.0%	11.5%	7.4%	0.0%	18.9%
PHF	0.646	0.878	0.000	0.925	0.000	0.000	0.781	0.864	0.000	0.819	0.000	0.000	0.864	0.721	0.000	0.845
Lights	58	244	0	302	0	0	158	30	0	188	0	0	69	45	0	114
% Lights	93.5%	93.8%	0.0%	93.8%	0.0%	0.0%	90.3%	78.9%	0.0%	88.3%	0.0%	0.0%	90.8%	91.8%	0.0%	91.2%
Trucks	0	0	0	0	0	0	0	0	0	0	0	0	0	0	0	0
% Trucks	0.0%	0.0%	0.0%	0.0%	0.0%	0.0%	0.0%	0.0%	0.0%	0.0%	0.0%	0.0%	0.0%	0.0%	0.0%	0.0%
Buses	4	16	0	20	0	0	17	8	0	25	0	0	7	4	0	11
% Buses	6.5%	6.2%	0.0%	0.0%	0.0%	0.0%	9.7%	21.1%	0.0%	0.0%	0.0%	0.0%	9.2%	8.2%	0.0%	0.0%
Pedestrians	0	0	0	0	0	0	0	0	0	0	0	0	0	0	0	0
% Pedestrians	0.0%	0.0%	0.0%	0.0%	0.0%	0.0%	0.0%	0.0%	0.0%	0.0%	0.0%	0.0%	0.0%	0.0%	0.0%	0.0%
Bicycles on Crosswalk	0	0	0	0	0	0	0	0	0	0	0	0	0	0	0	0
% Bicycles on Crosswalk	0.0%	0.0%	0.0%	0.0%	0.0%	0.0%	0.0%	0.0%	0.0%	0.0%	0.0%	0.0%	0.0%	0.0%	0.0%	0.0%

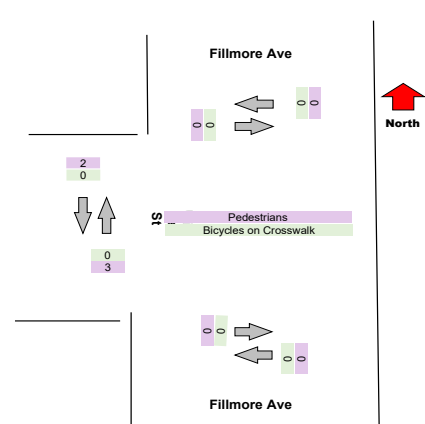
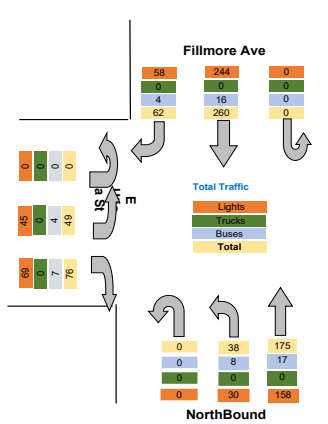

Turning Movement Peak Hour Data (PM)

4:30:00 PM

Leg Direction	Fillmore Ave Southbound						Fillmore Ave NorthBound						E Utica St Eastbound			
	Right	Thru	U-Turn	App Total	Peds CW	Peds CCW	Thru	Left	U-Turn	App Total	Peds CW	Peds CCW	Right	Left	U-Turn	App Total
4:30:00 PM	18	59	0	77	0	0	88	10	0	98	0	0	24	20	0	44
4:45:00 PM	15	81	0	96	0	1	82	18	0	100	1	0	30	27	0	57
5:00:00 PM	15	66	0	81	0	0	79	16	1	96	0	3	35	19	0	54
5:15:00 PM	10	73	0	83	0	0	79	21	0	100	1	1	23	22	0	45
Grand Total	58	279	0	337	0	1	328	65	1	394	2	4	112	88	0	200
% Approach	17.2%	82.8%	0.0%	0.0%	0.0%	0.0%	83.2%	16.5%	0.3%	0.0%	0.0%	0.0%	56.0%	44.0%	0.0%	0.0%
% Total	6.2%	30.0%	0.0%	36.2%	0.0%	0.0%	35.2%	7.0%	0.1%	42.3%	0.0%	0.0%	12.0%	9.5%	0.0%	21.5%
PHF	0.806	0.861	0.000	0.878	0.000	0.000	0.932	0.774	0.250	0.985	0.000	0.000	0.800	0.815	0.000	0.877
Lights	57	265	0	322	0	0	317	62	1	380	0	0	107	88	0	195
% Lights	98.3%	95.0%	0.0%	95.5%	0.0%	0.0%	96.6%	95.4%	100.0%	96.4%	0.0%	0.0%	95.5%	100.0%	0.0%	97.5%
Trucks	0	2	0	2	0	0	1	0	0	1	0	0	0	0	0	0
% Trucks	0.0%	0.7%	0.0%	0.6%	0.0%	0.0%	0.3%	0.0%	0.0%	0.3%	0.0%	0.0%	0.0%	0.0%	0.0%	0.0%
Buses	1	12	0	13	0	0	10	3	0	13	0	0	5	0	0	5
% Buses	1.7%	4.3%	0.0%	0.0%	0.0%	0.0%	3.0%	4.6%	0.0%	0.0%	0.0%	0.0%	4.5%	0.0%	0.0%	0.0%
Pedestrians	0	0	0	0	0	1	0	0	0	0	2	3	0	0	0	0
% Pedestrians	0.0%	0.0%	0.0%	0.0%	0.0%	100.0%	0.0%	0.0%	0.0%	0.0%	100.0%	75.0%	0.0%	0.0%	0.0%	0.0%
Bicycles on Crosswalk	0	0	0	0	0	0	0	0	0	0	0	1	0	0	0	0
% Bicycles on Crosswalk	0.0%	0.0%	0.0%	0.0%	0.0%	0.0%	0.0%	0.0%	0.0%	0.0%	0.0%	25.0%	0.0%	0.0%	0.0%	0.0%

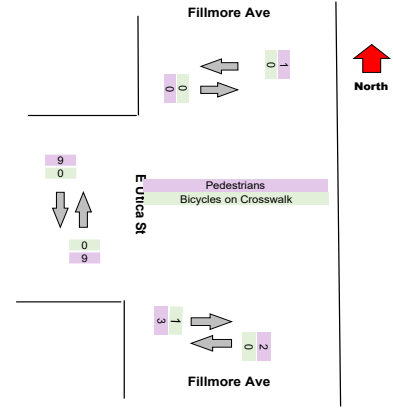
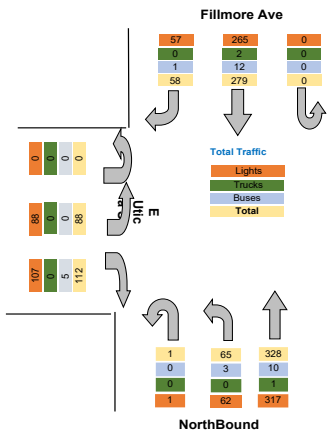

Intersection: Elm St Pine St
 Location: Kennett Square, PA
 Site: 01
 Survey Date: Wednesday, 04-28-2021
 GPS: 42.948550, -72.790034



Peds CW	Peds CCW	Total
0	0	49
0	0	85
0	0	134
2	0	98
1	0	96
1	2	149
1	0	165
5	2	508
1	0	179
0	0	167
1	0	346
0	2	226
4	1	229
0	2	219
6	0	253
10	5	927
3	4	231
0	3	228
4	1	203
0	1	200
7	9	862
23	16	2777
0.0%	0.0%	0.0%
0.0%	0.0%	0.0%
0	0	2599
0.0%	0.0%	93.6%
0	0	3
0.0%	0.0%	0.1%
0	0	174
0.0%	0.0%	6.3%
23	16	0
100.0%	100.0%	0.0%
0	0	0
0.0%	0.0%	0.0%

Intersection: Elm St Pine St
 Location: Kennett Square, PA
 Site: 01
 Survey Date: Wednesday, 04-28-2021
 GPS: 42.948550, -72.790034



Peds CW	Peds CCW	Total
1	2	149
1	0	165
1	0	179
0	0	167
3	2	660
0.0%	0.0%	
0.0%	0.0%	
0.000	0.000	0.922
0	0	604
0.0%	0.0%	91.5%
0	0	0
0.0%	0.0%	0.0%
0	0	56
0.0%	0.0%	8.5%
3	2	0
100.0%	100.0%	0.0%
0	0	0
0.0%	0.0%	0.0%

Intersection: Elm St Pine St
 Location: Kennett Square, PA
 Site: 01
 Survey Date: Wednesday, 04-28-2021
 GPS: 42.948550, -72.790034

Peds CW	Peds CCW	Total
0	2	219
6	0	253
3	4	231
0	3	228
9	9	931
0.0%	0.0%	
0.0%	0.0%	
0.000	0.000	0.920
0	0	897
0.0%	0.0%	96.3%
0	0	3
0.0%	0.0%	0.3%
0	0	31
0.0%	0.0%	3.3%
9	9	0
100.0%	100.0%	0.0%
0	0	0
0.0%	0.0%	0.0%

Project : VBH Malta NY
 Site : Site 4
 Location : 42.948550, -73.790036
 Survey Date : 2021-04-28, Wednesday

Turning Movement Data Plot

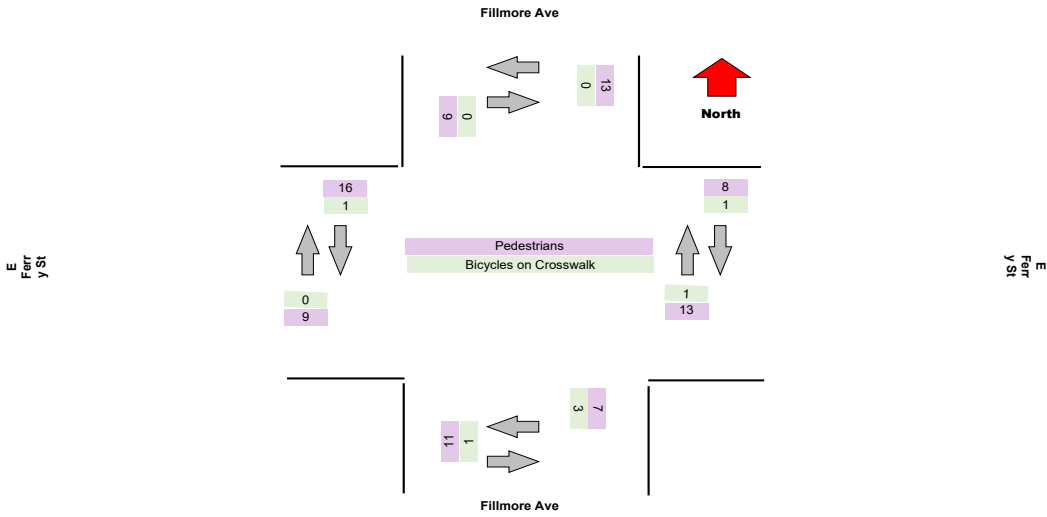
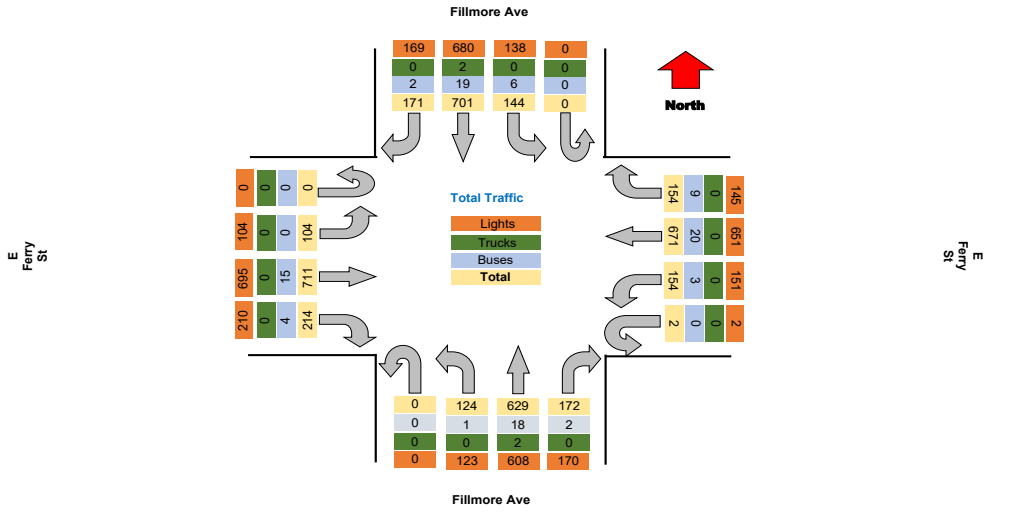

Project : VBH Malta NY
Site : Site 4
Location : 42.948550, -73.790036
Survey Date : 2021-04-28, Wednesday

TSTData.com

Turning Movement Peak Hour Data (AM)

7:30:00 AM

Leg Direction	Fillmore Ave						E Ferry St						Fillmore Ave						E Ferry St						Total				
	Southbound			Westbound			Northbound			Eastbound			Northbound			Eastbound													
Start Time	Right	Thru	Left	U-Turn	App Total	Peds CW	Peds CCW	Right	Thru	Left	U-Turn	App Total	Peds CW	Peds CCW	Right	Thru	Left	U-Turn	App Total	Peds CW	Peds CCW	Right	Thru	Left	U-Turn	App Total	Peds CW	Peds CCW	
7:30:00 AM	5	29	4	0	38	0	2	6	28	4	0	40	0	0	6	19	5	0	30	0	2	5	34	6	0	45	0	0	153
7:45:00 AM	14	47	8	0	69	0	0	7	36	7	0	50	0	0	5	37	4	0	46	0	0	8	50	7	0	65	0	1	230
8:00:00 AM	7	36	13	0	56	0	1	3	41	7	0	52	1	2	8	28	1	0	40	0	2	12	33	5	0	50	4	5	198
8:15:00 AM	9	39	4	0	52	0	1	7	36	8	0	52	0	1	3	27	7	0	38	0	0	12	32	5	0	49	0	0	191
Grand Total	35	151	29	0	215	0	4	23	141	26	0	194	1	5	22	111	17	0	154	0	4	37	149	23	0	299	4	6	772
% Approach	16.3%	70.2%	13.5%	0.0%	0.0%	0.0%	0.0%	11.9%	72.7%	13.4%	0.0%	0.0%	0.0%	0.0%	14.3%	72.1%	11.0%	0.0%	0.0%	0.0%	0.0%	17.7%	71.3%	11.0%	0.0%	0.0%	0.0%	0.0%	0.0%
% Total	4.5%	19.6%	3.8%	0.0%	27.8%	0.0%	0.0%	3.0%	18.3%	3.4%	0.0%	25.1%	0.0%	0.0%	2.8%	14.4%	2.2%	0.0%	19.9%	0.0%	0.0%	4.8%	19.3%	3.0%	0.0%	27.1%	0.0%	0.0%	0.0%
PHF	0.625	0.803	0.558	0.000	0.779	0.000	0.000	0.821	0.880	0.813	0.000	0.933	0.000	0.000	0.688	0.750	0.607	0.000	0.837	0.000	0.000	0.771	0.745	0.821	0.000	0.804	0.000	0.000	0.839
Lights	35	144	24	0	203	0	0	22	134	26	0	182	0	0	22	103	17	0	142	0	0	36	144	23	0	203	0	0	730
% Lights	100.0%	95.4%	82.8%	0.0%	94.4%	0.0%	0.0%	95.7%	95.0%	100.0%	0.0%	93.8%	0.0%	0.0%	100.0%	92.8%	100.0%	0.0%	92.2%	0.0%	0.0%	97.3%	96.6%	100.0%	0.0%	97.1%	0.0%	0.0%	94.6%
Trucks	0	0	0	0	0	0	0	0	0	0	0	0	0	0	0	1	0	0	1	0	0	0	0	0	0	0	0	0	1
% Trucks	0.0%	0.0%	0.0%	0.0%	0.0%	0.0%	0.0%	0.0%	0.0%	0.0%	0.0%	0.0%	0.0%	0.0%	0.0%	0.9%	0.0%	0.0%	0.6%	0.0%	0.0%	0.0%	0.0%	0.0%	0.0%	0.0%	0.0%	0.0%	0.1%
Buses	0	7	5	0	12	0	0	1	7	0	0	8	0	0	0	7	0	0	7	0	0	1	5	0	0	6	0	0	33
% Buses	0.0%	4.6%	17.2%	0.0%	0.0%	0.0%	0.0%	4.3%	5.0%	0.0%	0.0%	0.0%	0.0%	0.0%	0.0%	6.3%	0.0%	0.0%	0.0%	0.0%	0.0%	2.7%	3.4%	0.0%	0.0%	0.0%	0.0%	0.0%	4.3%
Pedestrians	0	0	0	0	0	0	4	0	0	0	0	1	3	0	0	0	0	0	0	3	0	0	0	0	0	0	4	6	0
% Pedestrians	0.0%	0.0%	0.0%	0.0%	0.0%	0.0%	100.0%	0.0%	0.0%	0.0%	0.0%	0.0%	100.0%	100.0%	0.0%	0.0%	0.0%	0.0%	0.0%	0.0%	75.0%	0.0%	0.0%	0.0%	0.0%	0.0%	100.0%	100.0%	0.0%
Bicycles on Crosswalk	0	0	0	0	0	0	0	0	0	0	0	0	0	0	0	0	0	0	0	0	1	0	0	0	0	0	0	0	0
% Bicycles on Crosswalk	0.0%	0.0%	0.0%	0.0%	0.0%	0.0%	0.0%	0.0%	0.0%	0.0%	0.0%	0.0%	0.0%	0.0%	0.0%	0.0%	0.0%	0.0%	0.0%	0.0%	25.0%	0.0%	0.0%	0.0%	0.0%	0.0%	0.0%	0.0%	0.0%

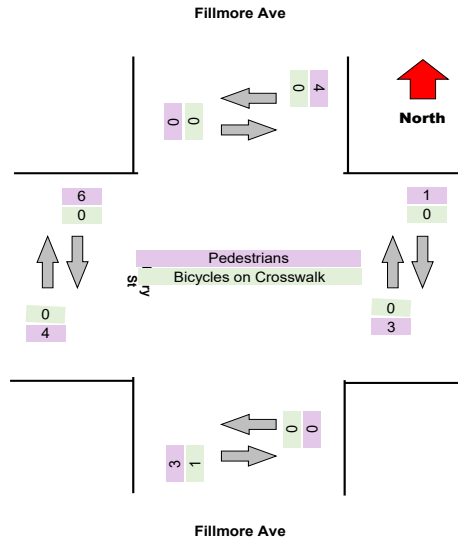
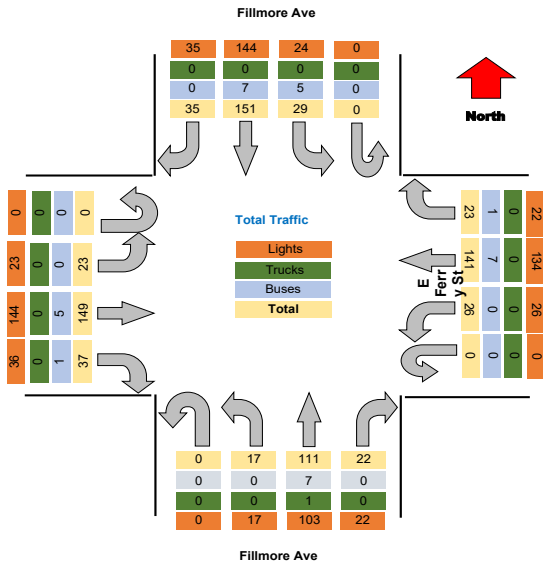

Project : VBH Malta NY
Site : Site 4
Location : 42.948550, -73.790036
Survey Date : 2021-04-28, Wednesday

TSTData.com

Turning Movement Peak Hour Data (PM)

4:30:00 PM

Leg Direction	Fillmore Ave										E Ferry St										Fillmore Ave										E Ferry St										Total																																												
	Southbound					Westbound					Northbound					Eastbound					Northbound					Eastbound																																																											
	Right	Thru	Left	U-Turn	App Total	Right	Thru	Left	U-Turn	App Total	Right	Thru	Left	U-Turn	App Total	Right	Thru	Left	U-Turn	App Total	Right	Thru	Left	U-Turn	App Total	Right	Thru	Left	U-Turn	App Total	Peds CW	Peds CCW																																																					
4:30:00 PM	14	61	11	0	86	2	1	13	53	9	0	75	0	1	17	50	10	0	77	0	0	15	61	4	0	80	0	1	16	54	8	0	76	2	3	27	51	12	0	90	0	2	25	56	12	0	94	0	1	59	285	47	0	352	0	0	58	223	54	0	335	1	2	63	231	49	0	343	3	4	84	233	32	0	349	3	5	1379							
4:45:00 PM	10	59	10	0	79	1	1	14	50	15	0	79	1	1	14	54	8	0	76	2	3	16	65	4	0	85	0	1	24	64	15	0	103	0	3	17	63	18	0	93	0	0	16	64	18	0	98	0	0	26	66	12	0	94	0	1	59	285	47	0	352	0	0	58	223	54	0	335	1	2	63	231	49	0	343	3	4	84	233	32	0	349	3	5	1379
5:00:00 PM	11	62	11	0	84	1	1	17	63	18	0	98	0	0	16	64	18	0	98	2	1	27	51	12	0	94	0	1	24	64	15	0	103	0	3	17	63	18	0	93	0	0	16	64	18	0	98	0	0	26	66	12	0	94	0	1	59	285	47	0	352	0	0	58	223	54	0	335	1	2	63	231	49	0	343	3	4	84	233	32	0	349	3	5	1379
Grand Total	59	285	47	0	352	0	0	58	223	54	0	335	1	2	63	231	49	0	343	3	4	84	233	32	0	349	3	5	1379																																																								
% Approach	16.8%	69.0%	13.4%	0.0%	0.0%	17.3%	66.6%	16.1%	0.0%	0.0%	18.4%	67.3%	14.3%	0.0%	0.0%	24.1%	66.8%	9.2%	0.0%	0.0%	24.1%	66.8%	9.2%	0.0%	0.0%	24.1%	66.8%	9.2%	0.0%	0.0%	0.0%	0.0%																																																					
% Total	4.3%	17.8%	3.4%	0.0%	25.6%	4.2%	16.2%	3.9%	0.0%	24.3%	4.6%	16.8%	3.6%	0.0%	24.9%	6.1%	16.9%	2.3%	0.0%	25.3%	6.1%	16.9%	2.3%	0.0%	25.3%	6.1%	16.9%	2.3%	0.0%	25.3%	0.0%	0.0%																																																					
PHF	0.615	0.961	0.783	0.000	0.854	0.853	0.885	0.750	0.000	0.855	0.926	0.902	0.681	0.000	0.875	0.778	0.896	0.667	0.000	0.928	0.778	0.896	0.667	0.000	0.928	0.778	0.896	0.667	0.000	0.928	0.000	0.000																																																					
Lights	59	239	46	0	344	57	220	52	0	329	63	226	49	0	338	83	230	32	0	345	83	230	32	0	345	83	230	32	0	345	0	0																																																					
% Lights	100.0%	97.2%	97.9%	0.0%	97.7%	98.3%	98.7%	96.3%	0.0%	98.2%	100.0%	97.8%	100.0%	0.0%	98.5%	98.8%	98.7%	100.0%	0.0%	98.9%	98.8%	98.7%	100.0%	0.0%	98.9%	98.8%	98.7%	100.0%	0.0%	98.9%	0.0%	0.0%																																																					
Trucks	0	2	0	0	2	0	0	0	0	0	0	1	0	0	1	0	0	0	0	0	0	0	0	0	0	0	0	0	0	0	0	0																																																					
% Trucks	0.0%	0.8%	0.0%	0.0%	0.6%	0.0%	0.0%	0.0%	0.0%	0.0%	0.0%	0.4%	0.0%	0.0%	0.3%	0.0%	0.0%	0.0%	0.0%	0.0%	0.0%	0.0%	0.0%	0.0%	0.0%	0.0%	0.0%	0.0%	0.0%	0.0%	0.0%	0.0%																																																					
Buses	0	5	1	0	6	1	3	2	0	6	0	3	0	0	3	1	2	0	0	3	1	2	0	0	3	1	2	0	0	3	0	0																																																					
% Buses	0.0%	2.0%	2.1%	0.0%	0.0%	1.7%	1.3%	3.7%	0.0%	0.0%	0.0%	1.3%	0.0%	0.0%	0.0%	1.2%	0.9%	0.0%	0.0%	0.0%	1.2%	0.9%	0.0%	0.0%	0.0%	1.2%	0.9%	0.0%	0.0%	0.0%	0.0%	0.0%																																																					
Pedestrians	0	0	0	0	0	4	6	0	0	0	0	0	0	0	0	4	0	0	0	0	4	0	0	0	0	4	0	0	0	0	4	0																																																					
% Pedestrians	0.0%	0.0%	0.0%	0.0%	0.0%	100.0%	100.0%	0.0%	0.0%	0.0%	0.0%	0.0%	0.0%	0.0%	0.0%	66.7%	100.0%	0.0%	0.0%	0.0%	66.7%	100.0%	0.0%	0.0%	0.0%	66.7%	100.0%	0.0%	0.0%	0.0%	0.0%	0.0%																																																					
Bicycles on Crosswalk	0	0	0	0	0	0	0	0	0	0	0	0	0	0	0	2	0	0	0	0	2	0	0	0	0	2	0	0	0	0	2	0																																																					
% Bicycles on Crosswalk	0.0%	0.0%	0.0%	0.0%	0.0%	0.0%	0.0%	0.0%	0.0%	0.0%	0.0%	0.0%	0.0%	0.0%	0.0%	33.3%	0.0%	0.0%	0.0%	0.0%	33.3%	0.0%	0.0%	0.0%	0.0%	33.3%	0.0%	0.0%	0.0%	0.0%	0.0%	0.0%																																																					

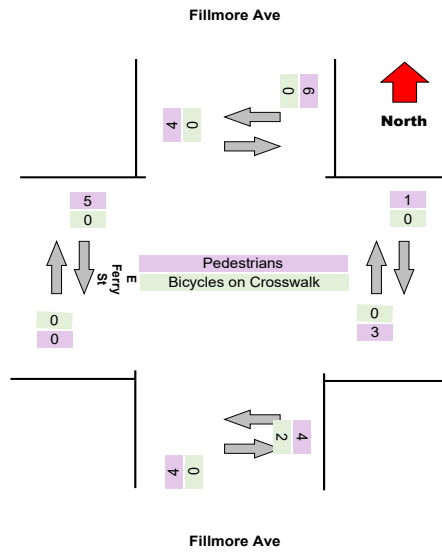
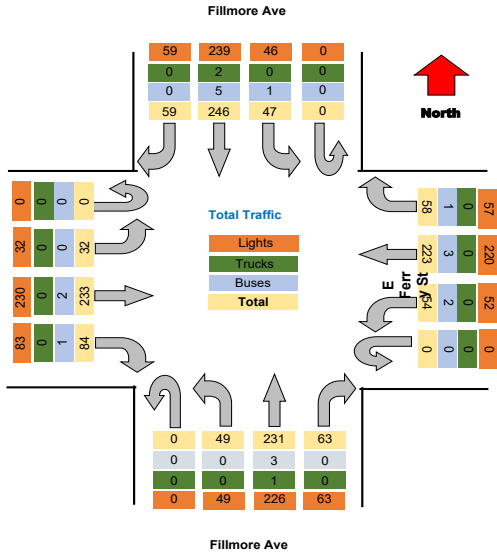

Project : VBH Malta NY
 Site : Site 4
 Location : 42.948550, -73.790036
 Survey Date : 2021-04-28, Wednesday

Turning Movement Data Plot

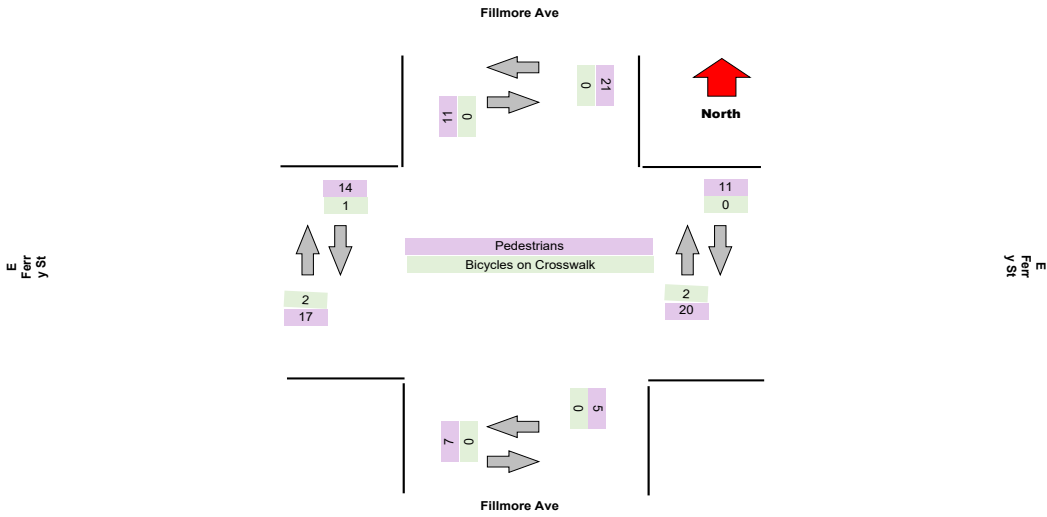
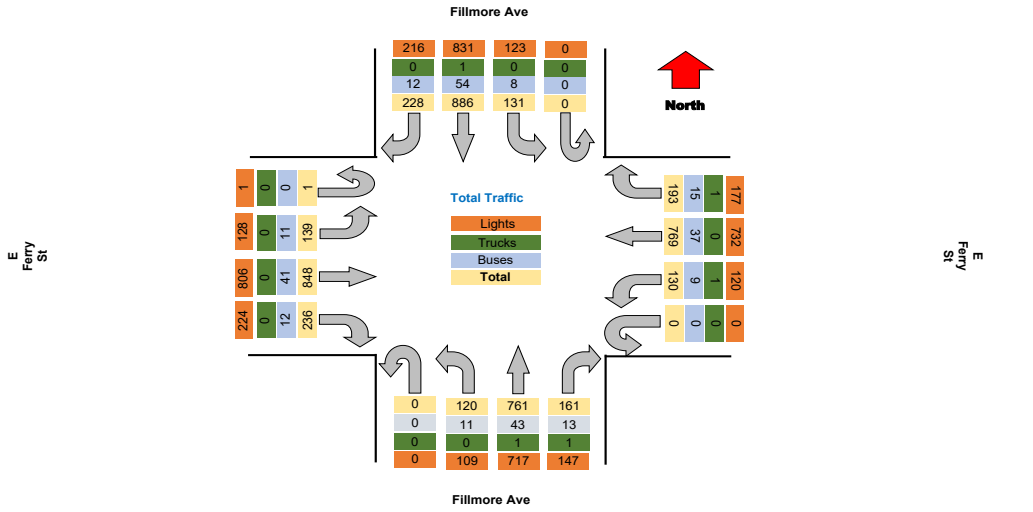

Project : VBH Malta NY
Site : Site 4
Location : 42.948550, -73.790036

TSTData.com

Survey Date : 2021-04-28, Wednesday

Turning Movement Peak Hour Data (AM)

7:30:00 AM

Leg Direction	Fillmore Ave						E Ferry St						Fillmore Ave						E Ferry St						Total				
	Southbound			Westbound			Northbound			Eastbound			Northbound			Eastbound													
Start Time	Right	Thru	Left	U-Turn	App Total	Peds CW	Peds CCW	Right	Thru	Left	U-Turn	App Total	Peds CW	Peds CCW	Right	Thru	Left	U-Turn	App Total	Peds CW	Peds CCW	Total							
7:30:00 AM	15	52	6	0	73	2	5	15	45	5	0	70	0	6	8	29	3	0	46	0	2	266							
7:45:00 AM	16	76	9	0	101	0	0	9	50	6	0	65	0	1	8	58	2	0	69	0	0	328							
8:00:00 AM	13	72	12	0	97	0	1	11	53	9	0	74	1	2	14	42	7	0	66	2	1	297							
8:15:00 AM	15	60	4	0	79	1	0	11	41	8	0	60	1	0	7	45	9	0	62	0	0	268							
Grand Total	59	269	31	0	350	3	6	46	199	28	0	259	2	9	37	174	21	0	243	2	3	1189							
% Approach	16.9%	74.3%	8.9%	0.0%	0.0%	0.0%	0.0%	17.1%	70.3%	10.4%	0.0%	0.0%	0.0%	0.0%	15.2%	71.6%	8.6%	0.0%	0.0%	0.0%	0.0%	18.2%	65.7%	15.8%	0.3%	0.0%	0.0%	0.0%	
% Total	5.1%	22.4%	2.7%	0.0%	30.2%	0.0%	0.0%	4.0%	16.3%	2.4%	0.0%	23.2%	0.0%	0.0%	3.2%	15.0%	1.8%	0.0%	21.0%	0.0%	0.0%	4.7%	16.8%	4.1%	0.1%	25.6%	0.0%	0.0%	0.0%
PHF	0.922	0.855	0.646	0.000	0.866	0.000	0.000	0.767	0.892	0.778	0.000	0.909	0.000	0.000	0.661	0.750	0.583	0.000	0.880	0.000	0.000	0.844	0.774	0.618	0.250	0.798	0.000	0.000	0.883
Lights	55	245	30	0	330	0	0	44	182	25	0	251	0	0	34	159	17	0	210	0	0	51	181	44	1	277	0	0	1068
% Lights	93.2%	94.2%	96.8%	0.0%	94.3%	0.0%	0.0%	95.7%	96.3%	89.3%	0.0%	93.3%	0.0%	0.0%	81.9%	91.4%	81.0%	0.0%	86.4%	0.0%	0.0%	94.4%	92.8%	93.6%	#####	93.3%	0.0%	0.0%	92.1%
Trucks	0	0	0	0	0	0	0	0	0	0	0	0	0	0	0	0	0	0	0	0	0	0	0	0	0	0	0	0	0
% Trucks	0.0%	0.0%	0.0%	0.0%	0.0%	0.0%	0.0%	0.0%	0.0%	0.0%	0.0%	0.0%	0.0%	0.0%	0.0%	0.0%	0.0%	0.0%	0.0%	0.0%	0.0%	0.0%	0.0%	0.0%	0.0%	0.0%	0.0%	0.0%	0.0%
Buses	4	15	1	0	20	0	0	2	7	3	0	12	0	0	3	15	4	0	22	0	0	3	14	3	0	20	0	0	74
% Buses	6.8%	5.8%	3.2%	0.0%	0.0%	0.0%	0.0%	4.3%	3.7%	10.7%	0.0%	0.0%	0.0%	0.0%	8.1%	8.8%	19.0%	0.0%	0.0%	0.0%	0.0%	5.8%	7.2%	6.4%	0.0%	0.0%	0.0%	0.0%	6.4%
Pedestrians	0	0	0	0	0	3	6	0	0	0	0	2	9	0	0	0	0	0	0	2	3	0	0	0	0	0	6	2	0
% Pedestrians	0.0%	0.0%	0.0%	0.0%	0.0%	100.0%	100.0%	0.0%	0.0%	0.0%	0.0%	0.0%	100.0%	100.0%	0.0%	0.0%	0.0%	0.0%	0.0%	0.0%	100.0%	100.0%	0.0%	0.0%	0.0%	0.0%	0.0%	100.0%	100.0%
Bicycles on Crosswalk	0	0	0	0	0	0	0	0	0	0	0	0	0	0	0	0	0	0	0	0	0	0	0	0	0	0	0	0	0
% Bicycles on Crosswalk	0.0%	0.0%	0.0%	0.0%	0.0%	0.0%	0.0%	0.0%	0.0%	0.0%	0.0%	0.0%	0.0%	0.0%	0.0%	0.0%	0.0%	0.0%	0.0%	0.0%	0.0%	0.0%	0.0%	0.0%	0.0%	0.0%	0.0%	0.0%	0.0%

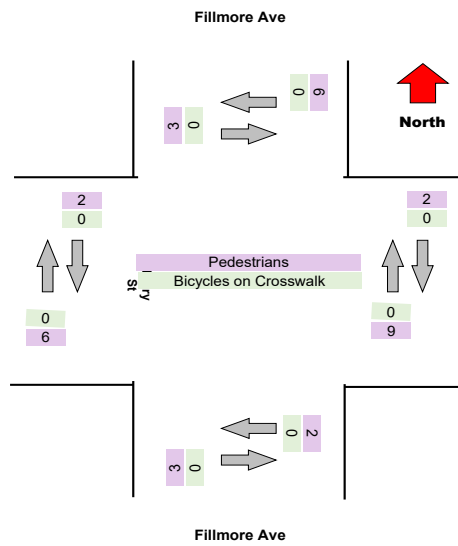
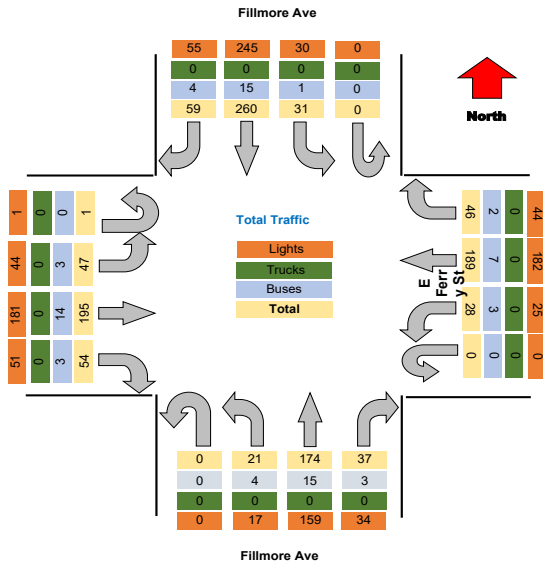

Turning Movement Peak Hour Data (PM)

4:30:00 PM

Leg Direction	Fillmore Ave										E Ferry St										Fillmore Ave										E Ferry St										Total
	Southbound					Westbound					Northbound					Eastbound																									
	Right	Thru	Left	U-Turn	App Total	Right	Thru	Left	U-Turn	App Total	Right	Thru	Left	U-Turn	App Total	Right	Thru	Left	U-Turn	App Total																					
4:30:00 PM	20	81	5	0	106	7	59	8	0	74	13	57	9	0	79	18	73	10	0	101	18	73	10	0	101	360															
4:45:00 PM	14	61	7	0	82	10	61	17	0	88	14	85	5	0	104	19	68	7	0	94	19	68	7	0	94	368															
5:00:00 PM	21	59	11	0	91	15	55	12	0	82	16	53	14	0	83	21	64	11	0	96	21	64	11	0	96	352															
5:15:00 PM	13	63	15	0	91	14	62	13	0	89	12	64	9	0	85	21	50	7	0	78	21	50	7	0	78	343															
Grand Total	58	264	38	0	370	46	237	50	0	333	55	259	37	0	351	79	255	35	0	369	79	255	35	0	369	1423															
% Approach	18.4%	71.4%	10.3%	0.0%	0.0%	13.8%	71.2%	15.0%	0.0%	0.0%	15.7%	73.8%	10.5%	0.0%	0.0%	21.4%	69.1%	9.5%	0.0%	0.0%	21.4%	69.1%	9.5%	0.0%	0.0%																
% Total	4.8%	18.6%	2.7%	0.0%	26.0%	3.2%	16.7%	3.5%	0.0%	23.4%	3.9%	18.2%	2.6%	0.0%	24.7%	5.6%	17.9%	2.5%	0.0%	25.9%	5.6%	17.9%	2.5%	0.0%	25.9%																
PHF	0.810	0.815	0.633	0.000	0.873	0.767	0.956	0.735	0.000	0.935	0.859	0.782	0.661	0.000	0.844	0.940	0.873	0.795	0.000	0.913	0.940	0.873	0.795	0.000	0.913	0.967															
Lights	66	250	38	0	354	42	230	48	0	320	50	250	35	0	335	77	245	32	0	354	77	245	32	0	354	1363															
% Lights	87.1%	94.7%	100.0%	0.0%	95.7%	81.3%	97.0%	96.0%	0.0%	96.1%	80.9%	96.5%	94.6%	0.0%	95.4%	97.5%	96.1%	91.4%	0.0%	95.9%	97.5%	96.1%	91.4%	0.0%	95.9%	95.8%															
Trucks	0	1	0	0	1	0	0	0	0	0	0	1	0	0	1	0	0	0	0	0	0	0	0	0	0	2															
% Trucks	0.0%	0.4%	0.0%	0.0%	0.3%	0.0%	0.0%	0.0%	0.0%	0.0%	0.0%	0.4%	0.0%	0.0%	0.3%	0.0%	0.0%	0.0%	0.0%	0.0%	0.0%	0.0%	0.0%	0.0%	0.0%	0.1%															
Buses	2	13	0	0	15	4	7	2	0	13	5	8	2	0	15	2	9	3	0	14	2	9	3	0	14	57															
% Buses	2.9%	4.9%	0.0%	0.0%	0.0%	8.7%	3.0%	4.0%	0.0%	0.0%	9.1%	3.1%	5.4%	0.0%	0.0%	2.5%	3.5%	8.6%	0.0%	0.0%	2.5%	3.5%	8.6%	0.0%	0.0%	4.0%															
Pedestrians	0	0	0	0	0	0	0	0	0	0	0	0	0	0	0	0	0	0	0	0	0	0	0	0	0	0															
% Pedestrians	0.0%	0.0%	0.0%	0.0%	0.0%	0.0%	0.0%	0.0%	0.0%	0.0%	0.0%	0.0%	0.0%	0.0%	0.0%	0.0%	0.0%	0.0%	0.0%	0.0%	0.0%	0.0%	0.0%	0.0%	0.0%	0.0%															
Bicycles on Crosswalk	0	0	0	0	0	0	0	0	0	0	0	0	0	0	0	0	0	0	0	0	0	0	0	0	0	0															
% Bicycles on Crosswalk	0.0%	0.0%	0.0%	0.0%	0.0%	0.0%	0.0%	0.0%	0.0%	0.0%	0.0%	0.0%	0.0%	0.0%	0.0%	0.0%	0.0%	0.0%	0.0%	0.0%	0.0%	0.0%	0.0%	0.0%	0.0%	0.0%															

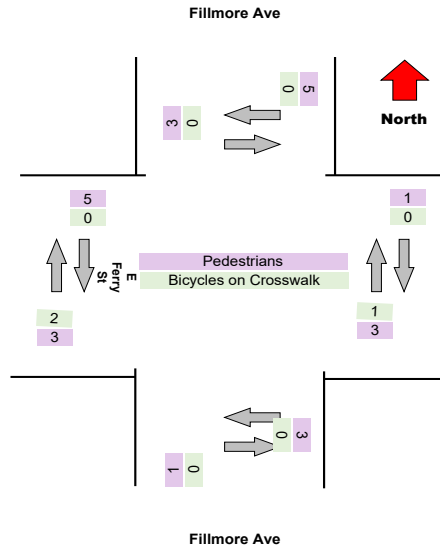
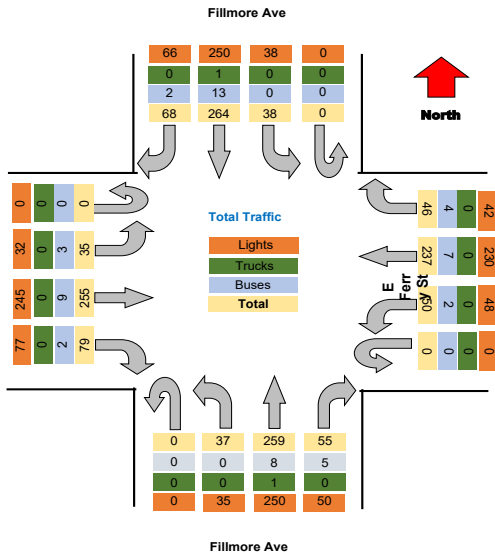

Project : VBH Malta NY
 Site : Site 4
 Location : 42.948550, -73.790036
 Survey Date : 2021-04-28, Wednesday

Turning Movement Data Plot

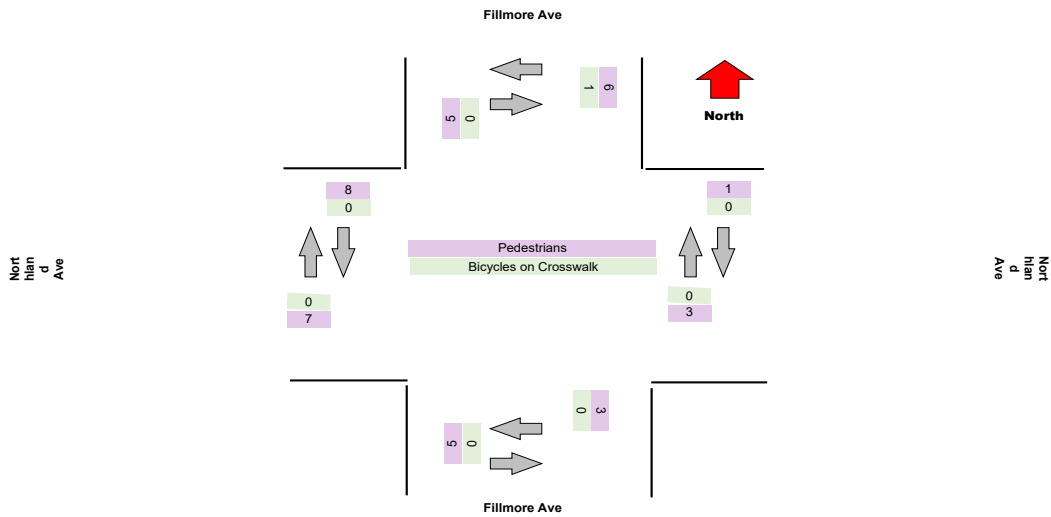
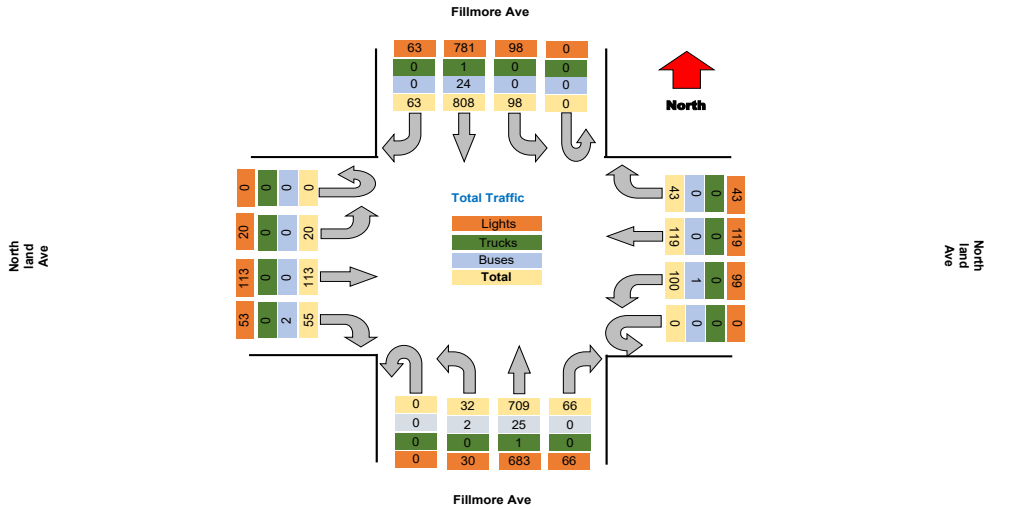

Turning Movement Peak Hour Data (AM)

7:30:00 AM

Leg Direction	Fillmore Ave					Northland Ave					Fillmore Ave					Northland Ave					Total								
	Southbound					Westbound					Northbound					Eastbound													
Start Time	Right	Thru	Left	U-Turn	App Total	Peds CW	Peds CCW	Right	Thru	Left	U-Turn	App Total	Peds CW	Peds CCW	Right	Thru	Left	U-Turn	App Total	Peds CW	Peds CCW	Right	Thru	Left	U-Turn	App Total	Peds CW	Peds CCW	
7:30:00 AM	7	31	8	0	46	0	1	2	7	4	0	14	0	0	3	22	2	0	27	0	0	2	8	0	0	10	0	1	97
7:45:00 AM	2	54	9	0	65	1	1	0	10	6	0	17	0	0	5	37	3	0	45	0	0	5	12	3	0	20	1	1	147
8:00:00 AM	3	50	4	0	57	1	0	2	7	2	0	11	0	0	5	33	0	0	38	1	1	1	5	0	0	6	1	1	112
8:15:00 AM	3	52	1	0	56	0	0	2	3	2	0	7	0	0	3	26	2	0	31	0	0	1	6	2	0	9	0	0	103
Grand Total	15	187	22	0	224	2	2	6	27	14	0	49	0	0	16	118	7	0	141	1	1	9	31	5	0	45	2	3	459
% Approach	6.7%	83.5%	9.8%	0.0%	0.0%	0.0%	0.0%	12.2%	55.1%	28.6%	0.0%	0.0%	0.0%	0.0%	11.3%	83.7%	5.0%	0.0%	0.0%	0.0%	0.0%	20.0%	65.9%	11.1%	0.0%	0.0%	0.0%	0.0%	0.0%
% Total	3.3%	40.7%	4.8%	0.0%	48.8%	0.0%	0.0%	1.3%	5.9%	3.1%	0.0%	10.7%	0.0%	0.0%	3.5%	25.7%	1.5%	0.0%	30.7%	0.0%	0.0%	2.0%	6.8%	1.1%	0.0%	9.8%	0.0%	0.0%	0.0%
PHF	0.536	0.866	0.611	0.000	0.862	0.000	0.000	0.750	0.675	0.583	0.000	0.721	0.000	0.000	0.800	0.797	0.583	0.000	0.783	0.000	0.000	0.450	0.646	0.417	0.000	0.563	0.000	0.000	0.781
Lights	15	174	22	0	211	0	0	6	27	14	0	47	0	0	16	111	6	0	133	0	0	9	31	5	0	45	0	0	436
% Lights	100.0%	93.0%	100.0%	0.0%	94.2%	0.0%	0.0%	100.0%	100.0%	100.0%	0.0%	95.9%	0.0%	0.0%	100.0%	94.1%	85.7%	0.0%	94.3%	0.0%	0.0%	100.0%	100.0%	100.0%	0.0%	100.0%	0.0%	0.0%	95.0%
Trucks	0	0	0	0	0	0	0	0	0	0	0	0	0	0	0	0	0	0	0	0	0	0	0	0	0	0	0	0	0
% Trucks	0.0%	0.0%	0.0%	0.0%	0.0%	0.0%	0.0%	0.0%	0.0%	0.0%	0.0%	0.0%	0.0%	0.0%	0.0%	0.0%	0.0%	0.0%	0.0%	0.0%	0.0%	0.0%	0.0%	0.0%	0.0%	0.0%	0.0%	0.0%	0.0%
Buses	0	12	0	0	12	0	0	0	0	0	0	0	0	0	0	7	1	0	8	0	0	0	0	0	0	0	0	0	20
% Buses	0.0%	6.4%	0.0%	0.0%	0.0%	0.0%	0.0%	0.0%	0.0%	0.0%	0.0%	0.0%	0.0%	0.0%	0.0%	5.9%	14.3%	0.0%	0.0%	0.0%	0.0%	0.0%	0.0%	0.0%	0.0%	0.0%	0.0%	0.0%	4.4%
Pedestrians	0	0	0	0	0	2	2	0	0	0	0	0	0	0	0	0	0	0	0	1	1	0	0	0	0	0	0	2	3
% Pedestrians	0.0%	0.0%	0.0%	0.0%	0.0%	100.0%	100.0%	0.0%	0.0%	0.0%	0.0%	0.0%	0.0%	0.0%	0.0%	0.0%	0.0%	0.0%	0.0%	0.0%	100.0%	100.0%	0.0%	0.0%	0.0%	0.0%	0.0%	100.0%	100.0%
Bicycles on Crosswalk	0	0	0	0	0	0	0	0	0	0	0	0	0	0	0	0	0	0	0	0	0	0	0	0	0	0	0	0	0
% Bicycles on Crosswalk	0.0%	0.0%	0.0%	0.0%	0.0%	0.0%	0.0%	0.0%	0.0%	0.0%	0.0%	0.0%	0.0%	0.0%	0.0%	0.0%	0.0%	0.0%	0.0%	0.0%	0.0%	0.0%	0.0%	0.0%	0.0%	0.0%	0.0%	0.0%	0.0%

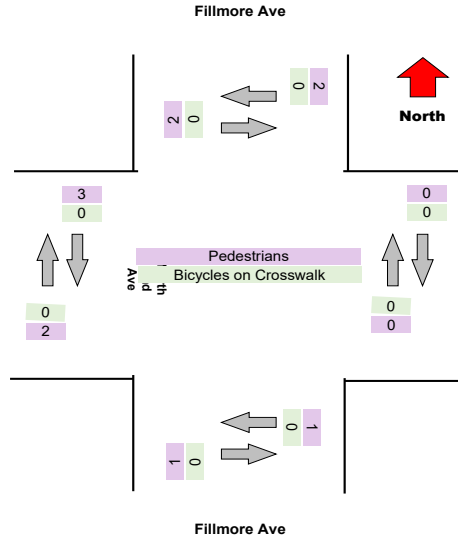
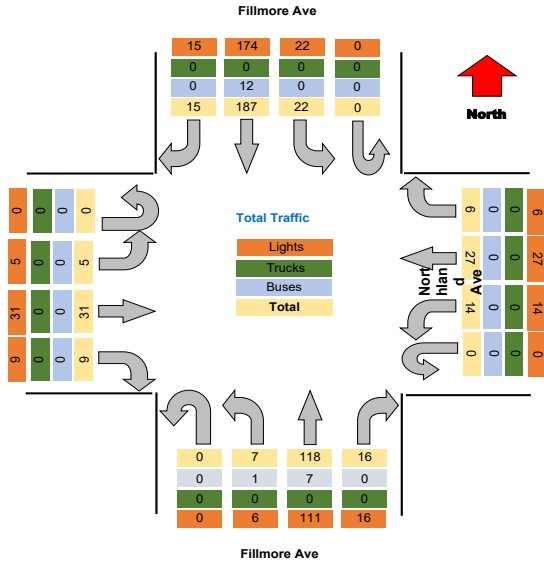

Turning Movement Peak Hour Data (PM)

4:45:00 PM

Leg Direction	Fillmore Ave										Northland Ave										Total									
	Southbound					Westbound					Northbound					Eastbound														
	Right	Thru	Left	U-Turn	App Total	Peds CW	Peds CCW	Right	Thru	Left	U-Turn	App Total	Peds CW	Peds CCW	Right	Thru	Left	U-Turn	App Total	Peds CW		Peds CCW								
4:45:00 PM	7	69	7	0	83	1	0	7	13	9	0	29	0	1	2	61	3	0	66	0	0	5	7	2	0	14	0	1	192	
5:00:00 PM	5	69	6	0	80	0	0	3	9	15	0	27	0	0	6	77	1	0	84	1	0	7	10	1	0	18	2	1	209	
5:15:00 PM	3	71	7	0	81	0	1	3	8	9	0	20	1	0	8	70	7	0	85	0	2	4	10	1	0	15	0	1	201	
5:30:00 PM	2	60	3	0	65	1	1	3	5	12	0	20	0	0	4	63	3	0	70	0	0	5	5	0	0	10	1	0	165	
Grand Total	17	269	23	0	309	2	2	16	35	45	0	95	1	1	20	271	14	0	305	1	2	21	32	4	0	57	3	3	787	
% Approach	5.5%	87.1%	7.4%	0.0%	0.0%	0.0%	0.0%	16.7%	36.5%	46.9%	0.0%	0.0%	0.0%	0.0%	6.6%	88.9%	4.6%	0.0%	0.0%	0.0%	0.0%	36.8%	56.1%	7.0%	0.0%	0.0%	0.0%	0.0%	0.0%	
% Total	2.2%	35.1%	3.0%	0.0%	40.3%	0.0%	0.0%	2.1%	4.6%	5.9%	0.0%	12.5%	0.0%	0.0%	2.6%	35.3%	1.8%	0.0%	39.8%	0.0%	0.0%	2.7%	4.2%	0.5%	0.0%	7.4%	0.0%	0.0%	0.0%	
PHF	0.607	0.947	0.821	0.000	0.931	0.000	0.000	0.571	0.673	0.750	0.000	0.828	0.000	0.000	0.625	0.880	0.500	0.000	0.897	0.000	0.000	0.750	0.800	0.500	0.000	0.792	0.000	0.000	0.917	
Lights	17	264	23	0	304	0	0	16	35	45	0	96	0	0	20	267	14	0	301	0	0	20	32	4	0	56	0	0	757	
% Lights	100.0%	98.1%	100.0%	0.0%	98.4%	0.0%	0.0%	100.0%	100.0%	100.0%	0.0%	100.0%	0.0%	0.0%	100.0%	98.5%	100.0%	0.0%	98.7%	0.0%	0.0%	95.2%	100.0%	100.0%	0.0%	98.2%	0.0%	0.0%	98.7%	
Trucks	0	0	0	0	0	0	0	0	0	0	0	0	0	0	0	1	0	0	1	0	0	0	0	0	0	0	0	0	1	
% Trucks	0.0%	0.0%	0.0%	0.0%	0.0%	0.0%	0.0%	0.0%	0.0%	0.0%	0.0%	0.0%	0.0%	0.0%	0.0%	0.4%	0.0%	0.0%	0.3%	0.0%	0.0%	0.0%	0.0%	0.0%	0.0%	0.0%	0.0%	0.0%	0.1%	
Buses	0	5	0	0	5	0	0	0	0	0	0	0	0	0	0	3	0	0	3	0	0	1	0	0	0	1	0	0	9	
% Buses	0.0%	1.9%	0.0%	0.0%	0.0%	0.0%	0.0%	0.0%	0.0%	0.0%	0.0%	0.0%	0.0%	0.0%	0.0%	1.1%	0.0%	0.0%	0.0%	0.0%	0.0%	4.8%	0.0%	0.0%	0.0%	0.0%	0.0%	0.0%	1.2%	
Pedestrians	0	0	0	0	0	2	1	0	0	0	0	1	1	1	0	0	0	0	0	1	2	0	0	0	0	0	3	3	0	
% Pedestrians	0.0%	0.0%	0.0%	0.0%	0.0%	100.0%	50.0%	0.0%	0.0%	0.0%	0.0%	0.0%	100.0%	100.0%	0.0%	0.0%	0.0%	0.0%	0.0%	0.0%	100.0%	100.0%	0.0%	0.0%	0.0%	0.0%	0.0%	100.0%	100.0%	0.0%
Bicycles on Crosswalk	0	0	0	0	0	0	1	0	0	0	0	0	0	0	0	0	0	0	0	0	0	0	0	0	0	0	0	0	0	
% Bicycles on Crosswalk	0.0%	0.0%	0.0%	0.0%	0.0%	0.0%	50.0%	0.0%	0.0%	0.0%	0.0%	0.0%	0.0%	0.0%	0.0%	0.0%	0.0%	0.0%	0.0%	0.0%	0.0%	0.0%	0.0%	0.0%	0.0%	0.0%	0.0%	0.0%	0.0%	

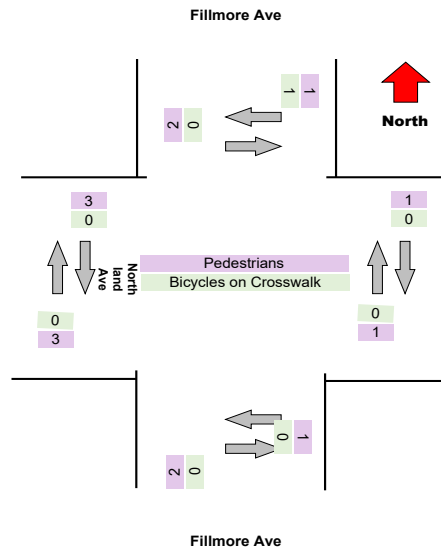
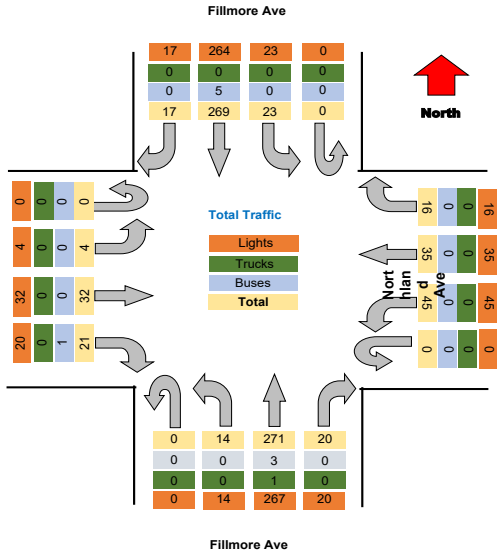

Project : VBH Malta NY
 Site : Site 4
 Location : 42.948550, -73.790036
 Survey Date : 2021-04-28, Wednesday

Turning Movement Data Plot

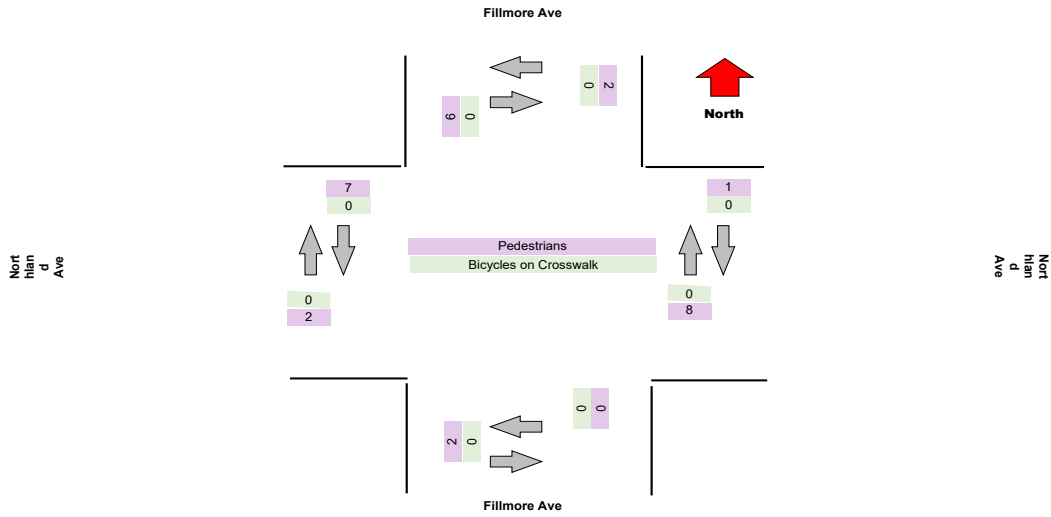
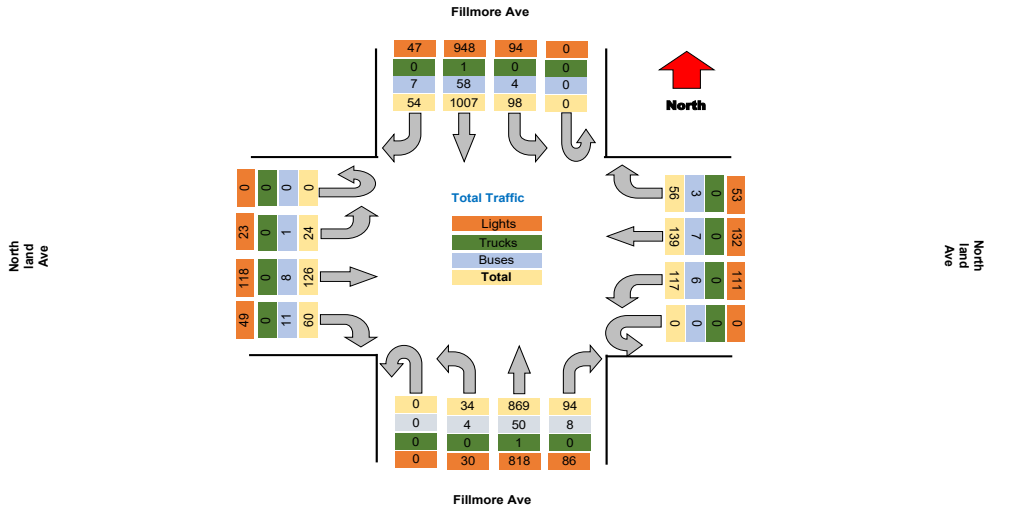

Turning Movement Peak Hour Data (AM)

7:30:00 AM

Leg Direction	Fillmore Ave						Northland Ave						Fillmore Ave						Northland Ave						Total				
	Southbound			Westbound			Northbound			Eastbound			Northbound			Eastbound													
Start Time	Right	Thru	Left	U-Turn	App Total	Peds CW	Peds CCW	Right	Thru	Left	U-Turn	App Total	Peds CW	Peds CCW	Right	Thru	Left	U-Turn	App Total	Peds CW	Peds CCW	Right	Thru	Left	U-Turn	App Total	Peds CW	Peds CCW	
7:30:00 AM	2	56	9	0	67	1	0	0	11	6	0	17	0	3	8	41	3	0	55	0	0	4	13	2	0	19	1	0	158
7:45:00 AM	1	88	14	0	103	0	0	1	8	6	0	15	0	1	6	74	2	0	83	0	0	3	11	4	0	18	0	0	219
8:00:00 AM	2	87	7	0	96	1	0	3	4	7	0	14	0	1	5	59	0	0	65	0	0	4	5	0	0	9	0	0	184
8:15:00 AM	3	67	7	0	77	0	0	2	6	7	0	15	0	0	10	43	3	0	56	0	0	2	5	0	0	7	0	0	155
Grand Total	8	298	37	0	343	2	0	6	29	26	0	51	0	5	29	217	8	0	299	0	0	13	34	6	0	53	1	0	716
% Approach	2.3%	86.0%	10.8%	0.0%	0.0%	0.0%	0.0%	9.8%	47.5%	42.6%	0.0%	0.0%	0.0%	0.0%	11.2%	83.6%	3.1%	0.0%	0.0%	0.0%	0.0%	24.5%	64.2%	11.3%	0.0%	0.0%	0.0%	0.0%	0.0%
% Total	1.1%	41.6%	5.2%	0.0%	47.9%	0.0%	0.0%	0.8%	4.1%	3.6%	0.0%	8.5%	0.0%	0.0%	4.1%	30.3%	1.1%	0.0%	36.2%	0.0%	0.0%	1.8%	4.7%	0.8%	0.0%	7.4%	0.0%	0.0%	0.0%
PHF	0.667	0.847	0.661	0.000	0.833	0.000	0.000	0.500	0.659	0.929	0.000	0.897	0.000	0.000	0.725	0.733	0.667	0.000	0.780	0.000	0.000	0.813	0.654	0.375	0.000	0.697	0.000	0.000	0.817
Lights	7	279	34	0	320	0	0	6	25	26	0	57	0	0	27	199	8	0	234	0	0	11	33	5	0	49	0	0	660
% Lights	87.5%	93.6%	91.9%	0.0%	93.3%	0.0%	0.0%	100.0%	86.2%	100.0%	0.0%	93.4%	0.0%	0.0%	93.1%	91.7%	100.0%	0.0%	90.3%	0.0%	0.0%	84.6%	97.1%	83.3%	0.0%	92.5%	0.0%	0.0%	92.2%
Trucks	0	0	0	0	0	0	0	0	0	0	0	0	0	0	0	0	0	0	0	0	0	0	0	0	0	0	0	0	0
% Trucks	0.0%	0.0%	0.0%	0.0%	0.0%	0.0%	0.0%	0.0%	0.0%	0.0%	0.0%	0.0%	0.0%	0.0%	0.0%	0.0%	0.0%	0.0%	0.0%	0.0%	0.0%	0.0%	0.0%	0.0%	0.0%	0.0%	0.0%	0.0%	0.0%
Buses	1	19	3	0	23	0	0	0	4	0	0	4	0	0	2	18	0	0	20	0	0	2	1	1	0	4	0	0	51
% Buses	12.5%	6.4%	8.1%	0.0%	6.7%	0.0%	0.0%	0.0%	13.8%	0.0%	0.0%	7.8%	0.0%	0.0%	6.9%	8.3%	0.0%	0.0%	6.7%	0.0%	0.0%	15.4%	2.9%	16.7%	0.0%	7.4%	0.0%	0.0%	7.1%
Pedestrians	0	0	0	0	0	2	0	0	0	0	0	0	5	0	0	0	0	0	0	0	0	0	0	0	0	0	1	0	0
% Pedestrians	0.0%	0.0%	0.0%	0.0%	0.0%	100.0%	0.0%	0.0%	0.0%	0.0%	0.0%	0.0%	100.0%	0.0%	0.0%	0.0%	0.0%	0.0%	0.0%	0.0%	0.0%	0.0%	0.0%	0.0%	0.0%	0.0%	100.0%	0.0%	0.0%
Bicycles on Crosswalk	0	0	0	0	0	0	0	0	0	0	0	0	0	0	0	0	0	0	0	0	0	0	0	0	0	0	0	0	0
% Bicycles on Crosswalk	0.0%	0.0%	0.0%	0.0%	0.0%	0.0%	0.0%	0.0%	0.0%	0.0%	0.0%	0.0%	0.0%	0.0%	0.0%	0.0%	0.0%	0.0%	0.0%	0.0%	0.0%	0.0%	0.0%	0.0%	0.0%	0.0%	0.0%	0.0%	0.0%

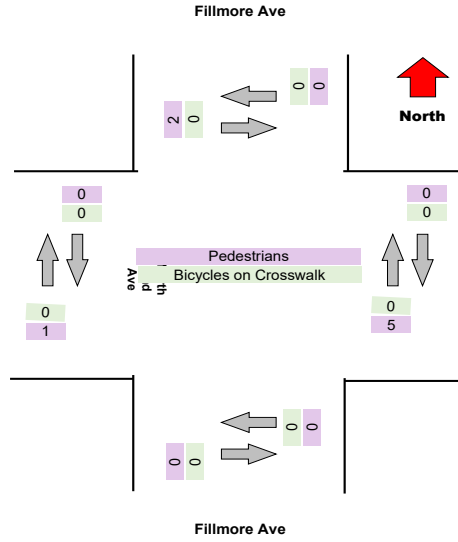
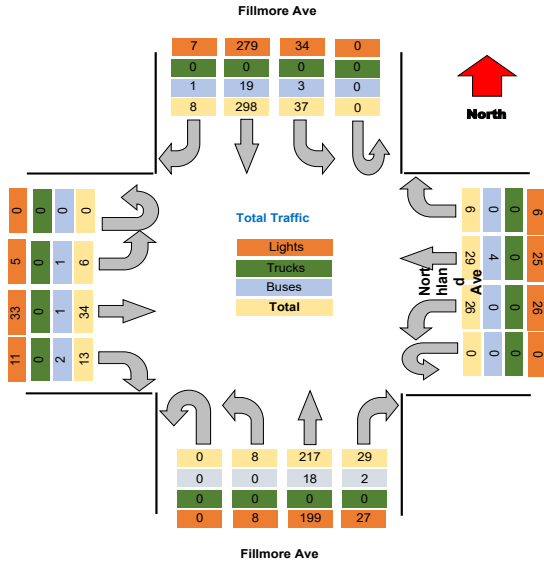

Turning Movement Peak Hour Data (PM)

4:45:00 PM

Leg Direction	Fillmore Ave										Northland Ave										Total								
	Southbound					Westbound					Northbound					Eastbound													
	Right	Thru	Left	U-Turn	App Total	Peds CW	Peds CCW	Right	Thru	Left	U-Turn	App Total	Peds CW	Peds CCW	Right	Thru	Left	U-Turn	App Total	Peds CW		Peds CCW							
4:45:00 PM	6	67	1	0	74	0	0	8	8	7	0	23	0	0	5	86	5	0	96	0	0	7	4	3	0	14	0	1	207
5:00:00 PM	1	72	3	0	76	0	0	3	12	9	0	24	0	0	9	65	3	0	77	0	0	5	4	3	0	12	0	0	189
5:15:00 PM	3	78	2	0	83	3	0	11	8	6	0	25	0	1	4	58	5	0	67	0	1	1	7	1	0	8	0	1	183
5:30:00 PM	4	67	5	0	76	0	0	5	12	2	0	19	0	0	4	56	0	0	60	0	0	8	7	1	0	16	0	0	180
Grand Total	14	284	11	0	309	3	0	27	40	24	0	91	0	1	22	274	13	0	309	0	1	21	22	7	0	50	0	2	759
% Approach	4.5%	91.9%	3.6%	0.0%	0.0%	0.0%	0.0%	29.7%	44.0%	26.4%	0.0%	0.0%	0.0%	0.0%	7.1%	88.7%	4.2%	0.0%	0.0%	0.0%	0.0%	42.0%	44.0%	14.0%	0.0%	0.0%	0.0%	0.0%	0.0%
% Total	1.8%	37.4%	1.4%	0.0%	40.7%	0.0%	0.0%	3.6%	5.3%	3.2%	0.0%	12.0%	0.0%	0.0%	2.9%	36.1%	1.7%	0.0%	40.7%	0.0%	0.0%	2.8%	2.9%	0.9%	0.0%	6.6%	0.0%	0.0%	0.0%
PHF	0.583	0.910	0.550	0.000	0.931	0.000	0.000	0.614	0.833	0.667	0.000	0.910	0.000	0.000	0.611	0.797	0.650	0.000	0.805	0.000	0.000	0.656	0.786	0.583	0.000	0.781	0.000	0.000	0.917
Lights	14	276	11	0	301	0	0	25	40	24	0	89	0	0	21	264	13	0	298	0	0	17	22	7	0	46	0	0	734
% Lights	100.0%	97.2%	100.0%	0.0%	97.4%	0.0%	0.0%	92.6%	100.0%	100.0%	0.0%	97.8%	0.0%	0.0%	85.5%	96.4%	100.0%	0.0%	96.4%	0.0%	0.0%	81.0%	100.0%	100.0%	0.0%	92.0%	0.0%	0.0%	96.7%
Trucks	0	0	0	0	0	0	0	0	0	0	0	0	0	0	0	0	0	0	0	0	0	0	0	0	0	0	0	0	0
% Trucks	0.0%	0.0%	0.0%	0.0%	0.0%	0.0%	0.0%	0.0%	0.0%	0.0%	0.0%	0.0%	0.0%	0.0%	0.0%	0.0%	0.0%	0.0%	0.0%	0.0%	0.0%	0.0%	0.0%	0.0%	0.0%	0.0%	0.0%	0.0%	0.0%
Buses	0	8	0	0	8	0	0	2	0	0	0	2	0	0	1	10	0	0	11	0	0	4	0	0	0	4	0	0	25
% Buses	0.0%	2.8%	0.0%	0.0%	0.0%	0.0%	0.0%	7.4%	0.0%	0.0%	0.0%	0.0%	0.0%	0.0%	4.5%	3.8%	0.0%	0.0%	0.0%	0.0%	0.0%	19.0%	0.0%	0.0%	0.0%	0.0%	0.0%	0.0%	3.3%
Pedestrians	0	0	0	0	0	3	0	0	0	0	0	0	1	0	0	0	0	1	0	0	0	0	0	0	0	0	2	0	0
% Pedestrians	0.0%	0.0%	0.0%	0.0%	0.0%	100.0%	0.0%	0.0%	0.0%	0.0%	0.0%	0.0%	100.0%	0.0%	0.0%	0.0%	0.0%	0.0%	0.0%	0.0%	0.0%	0.0%	0.0%	0.0%	0.0%	0.0%	0.0%	100.0%	0.0%
Bicycles on Crosswalk	0	0	0	0	0	0	0	0	0	0	0	0	0	0	0	0	0	0	0	0	0	0	0	0	0	0	0	0	0
% Bicycles on Crosswalk	0.0%	0.0%	0.0%	0.0%	0.0%	0.0%	0.0%	0.0%	0.0%	0.0%	0.0%	0.0%	0.0%	0.0%	0.0%	0.0%	0.0%	0.0%	0.0%	0.0%	0.0%	0.0%	0.0%	0.0%	0.0%	0.0%	0.0%	0.0%	0.0%

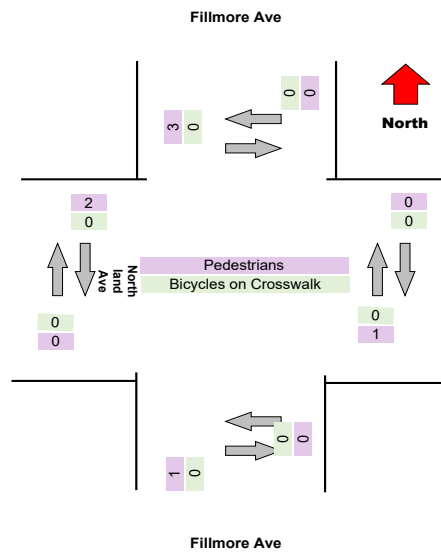
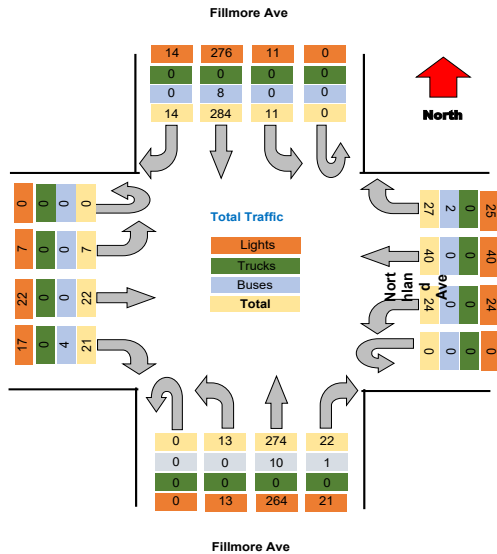

Project : VBH Malta NY
Site : Site 4
Location : 42.948550, -73.790036

TSTData.com

Survey Date : 2021-04-28, Wednesday

Project	LaBella
Project Code	LaBella
Site Name	25
Legs and Movements	All Processed Legs & Move
Bin Size	15 minutes
Survey Date	2021-11-04, Thursday
Location	25
Latitude and Longitude	42.914640, -78.839098

	Start	End	PHF
Forced Peak AM	2021/11/04 07:30:00	2021/11/04 08:30:00	0.96
Forced Peak PM	2021/11/04 16:30:00	2021/11/04 17:30:00	0.97
AM Peak	2021/11/04 07:30:00	2021/11/04 08:30:00	0.96
PM Peak	2021/11/04 16:45:00	2021/11/04 17:45:00	0.95

Turning Movement Data

Leg Direction	Fillmore Ave								Northland Ave								Fillmore Ave								Northland Ave								Total
	Southbound				Westbound				Northbound				Eastbound				Southbound				Westbound				Northbound				Eastbound				
	Right	Thru	Left	U-Turn	App Total	Peds CW	Peds CCW		Right	Thru	Left	U-Turn	App Total	Peds CW	Peds CCW		Right	Thru	Left	U-Turn	App Total	Peds CW	Peds CCW		Right	Thru	Left	U-Turn	App Total	Peds CW	Peds CCW		
6:30:00 AM	2	19	3	0	24	0	1	2	2	0	0	5	0	0	0	3	16	1	0	20	0	0	0	1	6	1	0	8	0	1	0	57	
6:45:00 AM	0	26	4	0	40	0	0	1	3	2	0	6	0	0	0	1	22	4	0	27	0	0	0	3	7	1	0	11	1	1	0	84	
Hourly Total	2	55	7	0	64	0	1	3	5	2	0	11	0	0	0	4	38	5	0	47	0	0	0	4	13	2	0	19	1	1	0	141	
7:00:00 AM	1	30	7	0	38	1	0	0	8	11	0	9	0	0	0	3	23	2	0	28	0	0	0	1	7	0	0	8	0	0	0	83	
7:15:00 AM	3	33	7	0	43	0	1	0	7	4	0	12	0	0	0	6	31	3	0	40	0	0	0	2	9	2	0	13	0	0	0	108	
7:30:00 AM	5	67	10	0	82	1	0	2	11	4	0	17	0	0	0	5	37	2	0	44	0	0	0	4	11	1	0	16	0	0	0	169	
7:45:00 AM	2	75	13	0	90	1	0	2	8	5	0	15	0	1	0	10	50	1	0	62	0	0	0	2	10	1	0	13	0	0	0	180	
Hourly Total	11	205	37	0	253	3	1	4	34	14	0	53	0	1	0	24	141	8	0	174	0	0	0	9	37	4	0	50	0	0	0	530	
8:00:00 AM	1	79	9	0	89	1	0	0	11	5	0	16	0	0	0	9	52	0	0	61	0	1	0	4	5	0	0	9	0	1	0	175	
8:15:00 AM	0	78	3	0	81	0	1	2	5	4	0	12	0	2	0	6	59	0	0	67	0	0	0	3	10	3	0	16	0	0	0	176	
Hourly Total	1	157	12	0	170	1	1	2	16	9	0	28	0	2	0	15	111	0	0	128	0	1	0	7	15	3	0	25	0	1	0	351	
4:00:00 PM	13	84	6	0	103	0	0	8	15	15	0	38	0	0	0	9	72	6	0	87	0	0	0	4	11	5	0	20	0	0	0	248	
4:15:00 PM	2	97	8	0	107	0	0	7	3	7	0	17	0	0	0	9	55	2	0	66	1	0	0	4	9	3	0	16	0	2	0	206	
4:30:00 PM	5	78	7	0	90	0	0	1	8	14	0	23	0	0	0	8	59	4	0	71	0	0	0	11	14	2	0	27	0	0	0	211	
4:45:00 PM	6	86	3	0	95	0	0	4	14	8	0	26	0	0	0	10	80	1	0	91	0	0	0	5	6	1	0	12	1	0	0	224	
Hourly Total	26	345	24	0	395	0	0	20	40	44	0	104	0	0	0	36	266	13	0	315	1	0	0	24	40	11	0	75	1	2	0	589	
5:00:00 PM	5	74	6	0	85	0	0	3	11	13	0	27	0	0	0	8	80	3	0	91	0	0	0	7	7	0	0	14	2	0	0	217	
5:15:00 PM	3	85	9	0	97	0	0	7	13	6	0	26	0	0	0	5	73	4	0	82	0	0	0	2	5	2	0	9	0	1	0	214	
5:30:00 PM	5	70	7	0	82	0	0	3	12	15	0	30	0	0	0	6	62	3	0	71	0	1	0	5	7	1	0	13	0	0	0	196	
5:45:00 PM	6	71	2	0	79	0	0	2	4	5	0	11	0	0	0	2	52	4	0	58	2	0	0	4	2	0	0	6	0	1	0	154	
Hourly Total	19	300	24	0	343	0	0	15	40	39	0	94	2	0	0	21	267	14	0	302	2	1	0	18	21	3	0	42	2	2	0	781	
Grand Total	59	1062	104	0	1225	4	3	44	135	108	0	290	2	3	0	100	823	40	0	966	3	2	0	62	126	23	0	211	4	6	0	2692	
% Approach	4.6%	86.7%	8.5%	0.0%	0.0%	0.0%	0.0%	15.2%	46.6%	37.2%	0.0%	0.0%	0.0%	0.0%	0.0%	10.4%	85.2%	4.1%	0.0%	0.0%	0.0%	0.0%	0.0%	29.4%	59.7%	10.9%	0.0%	0.0%	0.0%	0.0%	0.0%	0.0%	
% Total	2.2%	39.5%	3.9%	0.0%	45.5%	0.0%	0.0%	1.6%	5.0%	4.0%	0.0%	10.8%	0.0%	0.0%	0.0%	3.7%	30.6%	1.5%	0.0%	35.9%	0.0%	0.0%	0.0%	2.3%	4.7%	0.9%	0.0%	7.8%	0.0%	0.0%	0.0%	0.0%	
Lights	54	992	96	0	1142	0	0	42	129	104	0	275	0	0	0	90	776	36	0	902	0	0	0	53	119	21	0	193	0	0	0	2512	
% Lights	91.5%	93.4%	92.3%	0.0%	93.2%	0.0%	0.0%	95.5%	95.6%	96.3%	0.0%	94.8%	0.0%	0.0%	0.0%	80.0%	84.3%	90.0%	0.0%	93.4%	0.0%	0.0%	0.0%	85.5%	94.4%	91.3%	0.0%	91.5%	0.0%	0.0%	0.0%	93.3%	
Trucks	0	2	0	0	2	0	0	0	0	0	0	0	0	0	0	0	1	0	0	1	0	0	0	0	0	0	0	0	0	0	0	3	
% Trucks	0.0%	0.2%	0.0%	0.0%	0.2%	0.0%	0.0%	0.0%	0.0%	0.0%	0.0%	0.0%	0.0%	0.0%	0.0%	0.0%	0.1%	0.0%	0.1%	0.0%	0.0%	0.0%	0.0%	0.0%	0.0%	0.0%	0.0%	0.0%	0.0%	0.0%	0.1%		
Buses	5	68	8	0	81	0	0	2	6	4	0	12	0	0	0	10	46	4	0	60	0	0	0	9	7	2	0	18	0	0	0	171	
% Buses	8.5%	6.4%	7.7%	0.0%	0.0%	0.0%	0.0%	0.0%	4.4%	3.7%	0.0%	0.0%	0.0%	0.0%	0.0%	10.0%	5.6%	10.0%	0.0%	0.0%	0.0%	0.0%	14.5%	5.6%	8.7%	0.0%	0.0%	0.0%	0.0%	0.0%	6.4%		
Pedestrians	0	0	0	0	0	4	3	0	0	0	0	0	2	3	0	0	0	0	0	0	3	2	0	0	0	0	0	0	4	6	0	0	
% Pedestrians	0.0%	0.0%	0.0%	0.0%	0.0%	100.0%	100.0%	0.0%	0.0%	0.0%	0.0%	0.0%	100.0%	100.0%	0.0%	0.0%	0.0%	0.0%	0.0%	0.0%	0.0%	0.0%	0.0%	0.0%	0.0%	0.0%	0.0%	100.0%	100.0%	0.0%	0.0%		
Bicycles on Crosswalk	0	0	0	0	0	0	0	0	0	0	0	0	0	0	0	0	0	0	0	0	0	0	0	0	0	0	0	0	0	0	0	0	
% Bicycles on Crosswalk	0.0%	0.0%	0.0%	0.0%	0.0%	0.0%	0.0%	0.0%	0.0%	0.0%	0.0%	0.0%	0.0%	0.0%	0.0%	0.0%	0.0%	0.0%	0.0%	0.0%	0.0%	0.0%	0.0%	0.0%	0.0%	0.0%	0.0%	0.0%	0.0%	0.0%	0.0%		

Project : VBH Malta NY
 Site : Site 4
 Location : 42.948550, -73.790036
 Survey Date : 2021-04-28, Wednesday

Turning Movement Data Plot

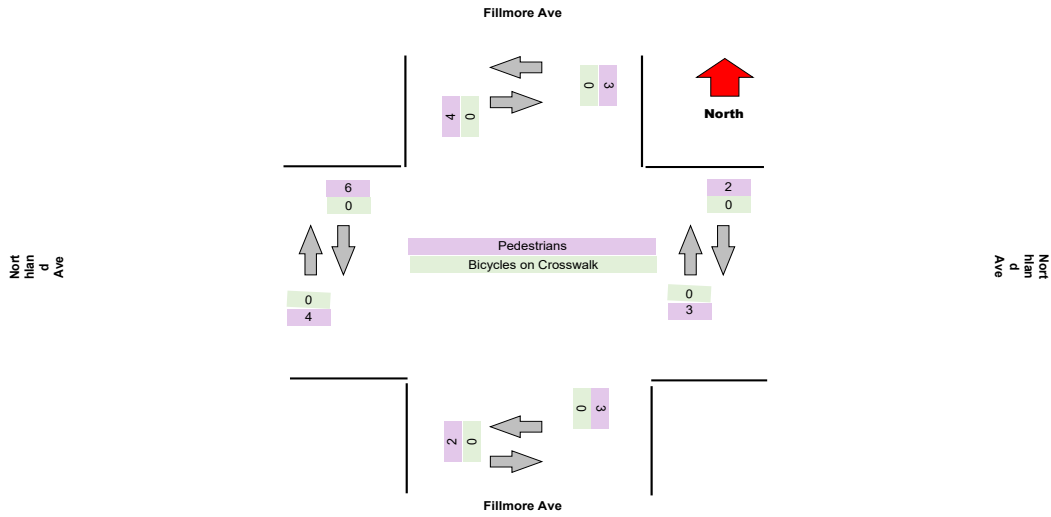
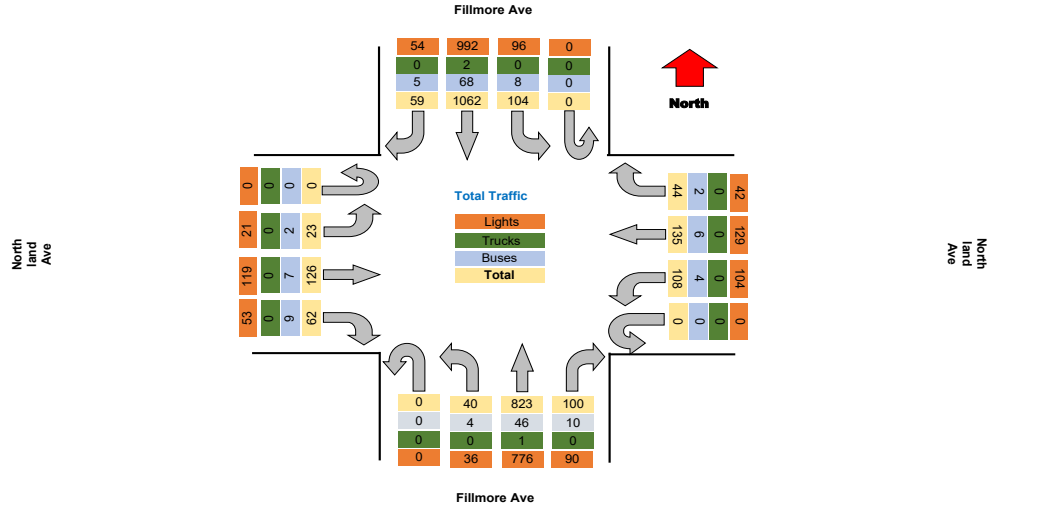

Project : VBH Malta NY
Site : Site 4
Location : 42.948550, -73.790036

TSTData.com

Survey Date : 2021-04-28, Wednesday

Turning Movement Peak Hour Data (AM)

7:30:00 AM

Leg Direction	Fillmore Ave						Northland Ave						Fillmore Ave						Northland Ave						Total				
	Southbound			Northbound			Westbound			Eastbound			Northbound			Eastbound													
Start Time	Right	Thru	Left	U-Turn	App Total	Peds CW	Peds CCW	Right	Thru	Left	U-Turn	App Total	Peds CW	Peds CCW	Right	Thru	Left	U-Turn	App Total	Peds CW	Peds CCW	Right	Thru	Left	U-Turn	App Total	Peds CW	Peds CCW	
7:30:00 AM	5	67	10	0	82	1	0	2	11	4	0	17	0	0	5	37	2	0	44	0	0	4	11	1	0	16	0	0	159
7:45:00 AM	2	75	13	0	90	1	0	2	8	5	0	15	0	1	10	50	1	0	62	0	0	2	10	1	0	13	0	0	180
8:00:00 AM	1	79	9	0	89	1	0	0	11	5	0	16	0	0	9	52	0	0	61	0	1	4	5	0	0	9	0	1	175
8:15:00 AM	0	78	3	0	81	0	0	2	5	4	0	12	0	2	6	58	0	0	67	0	0	3	10	3	0	16	0	0	178
Grand Total	8	299	35	0	342	3	0	6	35	18	0	59	0	3	30	198	3	0	234	0	1	13	36	5	0	54	3	1	690
% Approach	2.3%	87.4%	10.2%	0.0%	0.0%	0.0%	0.0%	10.0%	58.3%	30.0%	0.0%	0.0%	0.0%	0.0%	12.8%	84.6%	1.3%	0.0%	0.0%	0.0%	0.0%	24.1%	66.7%	9.3%	0.0%	0.0%	0.0%	0.0%	0.0%
% Total	1.2%	43.3%	5.1%	0.0%	48.6%	0.0%	0.0%	0.9%	5.1%	2.6%	0.0%	8.7%	0.0%	0.0%	4.3%	28.7%	0.4%	0.0%	33.9%	0.0%	0.0%	1.9%	5.2%	0.7%	0.0%	7.8%	0.0%	0.0%	0.0%
PHF	0.400	0.946	0.673	0.000	0.950	0.000	0.000	0.750	0.795	0.900	0.000	0.882	0.000	0.000	0.750	0.839	0.375	0.000	0.873	0.000	0.000	0.813	0.818	0.417	0.000	0.844	0.000	0.000	0.958
Lights	7	279	30	0	316	0	0	5	31	18	0	54	0	0	26	181	3	0	210	0	0	11	35	4	0	50	0	0	630
% Lights	87.5%	93.3%	85.7%	0.0%	92.4%	0.0%	0.0%	83.3%	88.6%	100.0%	0.0%	90.0%	0.0%	0.0%	86.7%	91.4%	100.0%	0.0%	89.7%	0.0%	0.0%	84.6%	97.2%	80.0%	0.0%	92.6%	0.0%	0.0%	91.3%
Trucks	0	0	0	0	0	0	0	0	0	0	0	0	0	0	0	0	0	0	0	0	0	0	0	0	0	0	0	0	0
% Trucks	0.0%	0.0%	0.0%	0.0%	0.0%	0.0%	0.0%	0.0%	0.0%	0.0%	0.0%	0.0%	0.0%	0.0%	0.0%	0.0%	0.0%	0.0%	0.0%	0.0%	0.0%	0.0%	0.0%	0.0%	0.0%	0.0%	0.0%	0.0%	0.0%
Buses	1	20	5	0	26	0	0	1	4	0	0	5	0	0	4	17	0	0	21	0	0	2	1	1	0	4	0	0	56
% Buses	12.5%	6.7%	14.3%	0.0%	0.0%	0.0%	0.0%	16.7%	11.4%	0.0%	0.0%	0.0%	0.0%	0.0%	13.3%	8.6%	0.0%	0.0%	0.0%	0.0%	0.0%	15.4%	2.8%	20.0%	0.0%	0.0%	0.0%	0.0%	8.1%
Pedestrians	0	0	0	0	0	3	1	0	0	0	0	0	3	0	0	0	0	0	0	0	1	0	0	0	0	0	0	1	0
% Pedestrians	0.0%	0.0%	0.0%	0.0%	0.0%	100.0%	100.0%	0.0%	0.0%	0.0%	0.0%	0.0%	0.0%	0.0%	0.0%	0.0%	0.0%	0.0%	0.0%	0.0%	0.0%	0.0%	0.0%	0.0%	0.0%	0.0%	0.0%	100.0%	0.0%
Bicycles on Crosswalk	0	0	0	0	0	0	0	0	0	0	0	0	0	0	0	0	0	0	0	0	0	0	0	0	0	0	0	0	0
% Bicycles on Crosswalk	0.0%	0.0%	0.0%	0.0%	0.0%	0.0%	0.0%	0.0%	0.0%	0.0%	0.0%	0.0%	0.0%	0.0%	0.0%	0.0%	0.0%	0.0%	0.0%	0.0%	0.0%	0.0%	0.0%	0.0%	0.0%	0.0%	0.0%	0.0%	0.0%

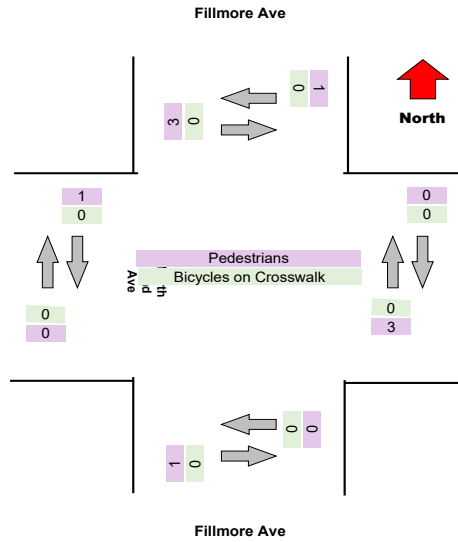
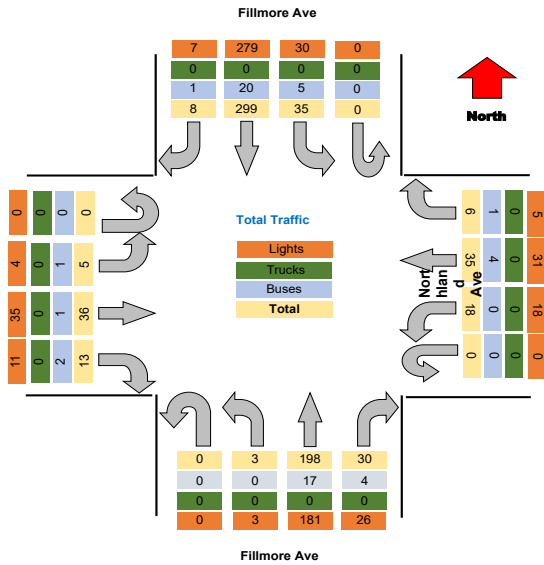

Turning Movement Peak Hour Data (PM)

4:45:00 PM

Leg Direction	Fillmore Ave										Northland Ave										Total									
	Southbound					Westbound					Northbound					Eastbound														
	Right	Thru	Left	U-Turn	App Total	Peds CW	Peds CCW	Right	Thru	Left	U-Turn	App Total	Peds CW	Peds CCW	Right	Thru	Left	U-Turn	App Total	Peds CW		Peds CCW								
4:45:00 PM	6	86	3	0	95	0	0	4	14	8	0	26	0	0	10	80	1	0	91	0	0	5	6	1	0	12	1	0	224	
5:00:00 PM	5	74	6	0	85	0	0	3	11	13	0	27	0	0	8	80	3	0	91	0	0	7	7	0	0	14	2	0	217	
5:15:00 PM	3	85	9	0	97	0	0	7	13	6	0	26	0	0	5	73	4	0	82	0	0	2	5	2	0	9	0	1	214	
5:30:00 PM	5	70	7	0	82	0	0	3	12	15	0	30	0	0	6	62	3	0	71	0	1	5	7	1	0	13	0	0	196	
Grand Total	19	315	25	0	359	0	0	17	50	42	0	109	0	0	29	295	11	0	335	0	1	19	25	4	0	48	3	1	851	
% Approach	5.3%	87.7%	7.0%	0.0%	0.0%	0.0%	0.0%	15.6%	45.9%	38.5%	0.0%	0.0%	0.0%	0.0%	8.7%	88.1%	3.3%	0.0%	0.0%	0.0%	0.0%	39.6%	52.1%	8.3%	0.0%	0.0%	0.0%	0.0%	0.0%	
% Total	2.2%	37.0%	2.9%	0.0%	42.2%	0.0%	0.0%	2.0%	5.9%	4.9%	0.0%	12.8%	0.0%	0.0%	3.4%	34.7%	1.3%	0.0%	39.4%	0.0%	0.0%	2.2%	2.9%	0.5%	0.0%	5.6%	0.0%	0.0%	0.0%	
PHF	0.792	0.916	0.694	0.000	0.925	0.000	0.000	0.607	0.893	0.700	0.000	0.908	0.000	0.000	0.725	0.922	0.688	0.000	0.820	0.000	0.000	0.679	0.893	0.500	0.000	0.857	0.000	0.000	0.950	
Lights	19	302	25	0	346	0	0	16	50	42	0	108	0	0	28	286	11	0	325	0	1	17	23	4	0	44	0	0	823	
% Lights	100.0%	95.9%	100.0%	0.0%	96.4%	0.0%	0.0%	84.1%	100.0%	100.0%	0.0%	99.1%	0.0%	0.0%	96.6%	96.9%	100.0%	0.0%	97.0%	0.0%	0.0%	89.5%	92.0%	100.0%	0.0%	91.7%	0.0%	0.0%	96.7%	
Trucks	0	1	0	0	1	0	0	0	0	0	0	0	0	0	0	1	0	0	1	0	0	0	0	0	0	0	0	0	2	
% Trucks	0.0%	0.3%	0.0%	0.0%	0.3%	0.0%	0.0%	0.0%	0.0%	0.0%	0.0%	0.0%	0.0%	0.0%	0.0%	0.3%	0.0%	0.0%	0.3%	0.0%	0.0%	0.0%	0.0%	0.0%	0.0%	0.0%	0.0%	0.0%	0.2%	
Buses	0	12	0	0	12	0	0	1	0	0	0	1	0	0	1	8	0	0	9	0	0	2	2	0	0	4	0	0	26	
% Buses	0.0%	3.8%	0.0%	0.0%	0.0%	0.0%	0.0%	5.9%	0.0%	0.0%	0.0%	0.0%	0.0%	0.0%	3.4%	2.7%	0.0%	0.0%	0.0%	0.0%	0.0%	10.5%	8.0%	0.0%	0.0%	0.0%	0.0%	0.0%	3.1%	
Pedestrians	0	0	0	0	0	0	0	0	0	0	0	0	0	0	0	0	0	1	0	0	1	0	0	0	0	0	0	3	1	0
% Pedestrians	0.0%	0.0%	0.0%	0.0%	0.0%	0.0%	0.0%	0.0%	0.0%	0.0%	0.0%	0.0%	0.0%	0.0%	0.0%	0.0%	0.0%	0.0%	0.0%	0.0%	0.0%	0.0%	0.0%	0.0%	0.0%	0.0%	0.0%	0.0%	0.0%	
Bicycles on Crosswalk	0	0	0	0	0	0	0	0	0	0	0	0	0	0	0	0	0	0	0	0	0	0	0	0	0	0	0	0	0	
% Bicycles on Crosswalk	0.0%	0.0%	0.0%	0.0%	0.0%	0.0%	0.0%	0.0%	0.0%	0.0%	0.0%	0.0%	0.0%	0.0%	0.0%	0.0%	0.0%	0.0%	0.0%	0.0%	0.0%	0.0%	0.0%	0.0%	0.0%	0.0%	0.0%	0.0%	0.0%	

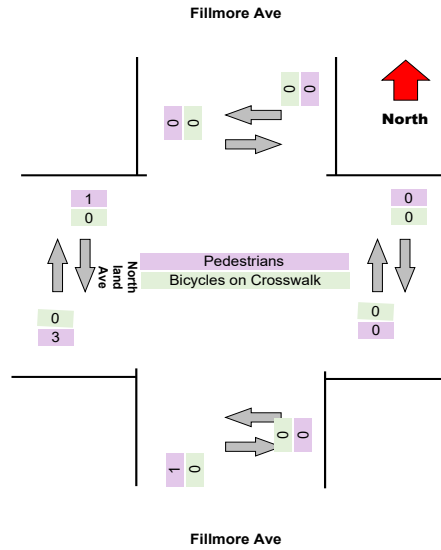
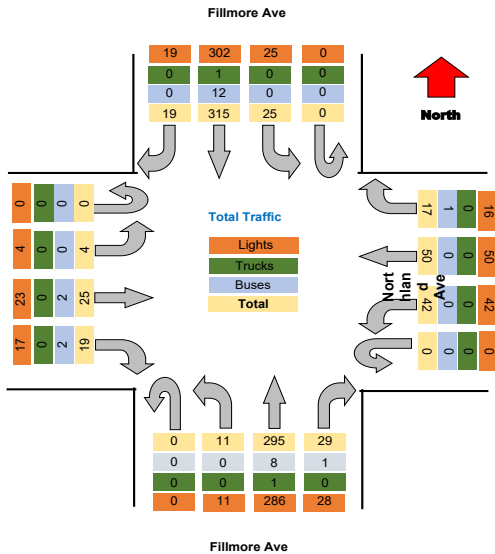

Turning Movement Data Plot

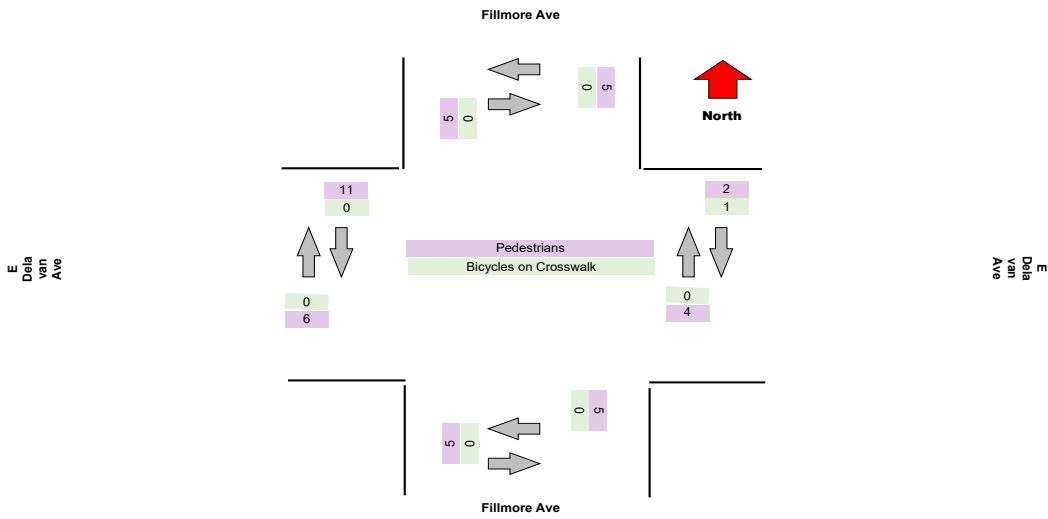
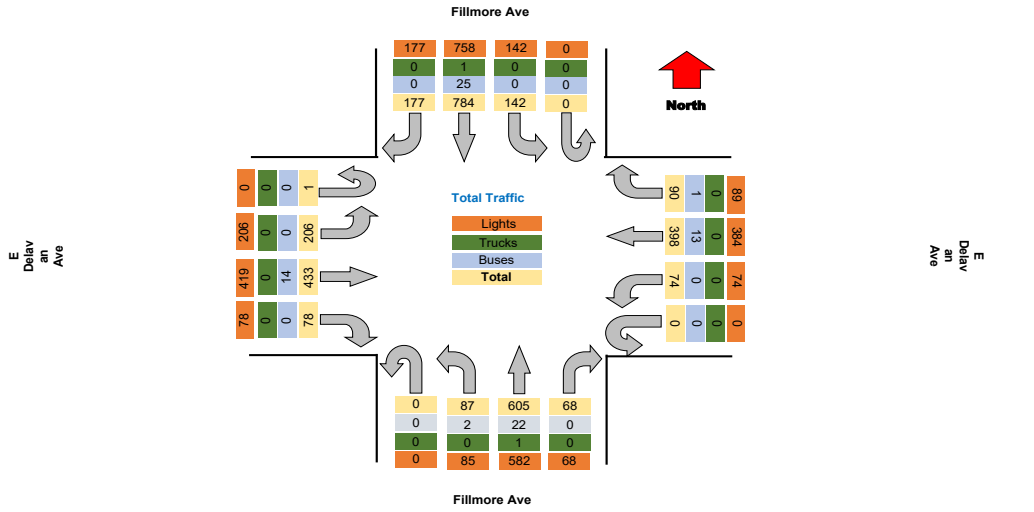

Project : VBH Malta NY
Site : Site 4
Location : 42.948550, -73.790036
Survey Date : 2021-04-28, Wednesday

TSTData.com

Turning Movement Peak Hour Data (AM)

7:30:00 AM

Leg Direction	Fillmore Ave								E Delavan Ave								Fillmore Ave								E Delavan Ave								Total
	Southbound				Westbound				Northbound				Eastbound																				
Start Time	Right	Thru	Left	U-Turn	App Total	Peds CW	Peds CCW	Right	Thru	Left	U-Turn	App Total	Peds CW	Peds CCW	Right	Thru	Left	U-Turn	App Total	Peds CW	Peds CCW	Right	Thru	Left	U-Turn	App Total	Peds CW	Peds CCW					
7:30:00 AM	8	42	8	0	58	0	0	5	19	2	0	26	0	0	3	21	5	0	29	0	0	3	13	9	0	25	0	0	138				
7:45:00 AM	9	53	11	0	73	0	0	5	21	2	0	28	1	1	1	34	4	0	41	1	1	4	26	9	0	39	0	1	181				
8:00:00 AM	6	49	6	0	61	0	1	4	15	4	0	24	0	0	2	30	1	0	33	1	1	3	19	8	0	30	1	0	148				
8:15:00 AM	12	46	9	0	67	0	0	3	21	3	0	27	0	0	3	17	5	0	25	0	0	3	19	12	0	34	0	1	153				
Grand Total	35	190	34	0	259	0	1	17	76	11	0	105	1	1	9	102	15	0	128	2	2	13	77	38	0	128	1	2	620				
% Approach	13.5%	73.4%	13.1%	0.0%	0.0%	0.0%	0.0%	16.2%	72.4%	10.5%	0.0%	0.0%	0.0%	0.0%	7.0%	79.7%	11.7%	0.0%	0.0%	0.0%	0.0%	10.2%	60.2%	29.7%	0.0%	0.0%	0.0%	0.0%	0.0%				
% Total	5.6%	30.6%	5.5%	0.0%	41.8%	0.0%	0.0%	2.7%	12.3%	1.8%	0.0%	16.9%	0.0%	0.0%	1.5%	16.5%	2.4%	0.0%	20.6%	0.0%	0.0%	2.1%	12.4%	6.1%	0.0%	20.6%	0.0%	0.0%	0.0%				
PHF	0.729	0.896	0.773	0.000	0.887	0.000	0.000	0.850	0.905	0.888	0.000	0.938	0.000	0.000	0.750	0.750	0.750	0.000	0.780	0.000	0.000	0.813	0.740	0.792	0.000	0.821	0.000	0.000	0.856				
Lights	35	177	34	0	246	0	0	17	73	11	0	101	0	0	9	95	14	0	118	0	0	13	73	38	0	124	0	0	589				
% Lights	100.0%	93.2%	100.0%	0.0%	95.0%	0.0%	0.0%	100.0%	96.1%	100.0%	0.0%	96.2%	0.0%	0.0%	100.0%	93.1%	93.3%	0.0%	92.2%	0.0%	0.0%	100.0%	94.8%	100.0%	0.0%	96.9%	0.0%	0.0%	95.0%				
Trucks	0	0	0	0	0	0	0	0	0	0	0	0	0	0	0	0	0	0	0	0	0	0	0	0	0	0	0	0	0				
% Trucks	0.0%	0.0%	0.0%	0.0%	0.0%	0.0%	0.0%	0.0%	0.0%	0.0%	0.0%	0.0%	0.0%	0.0%	0.0%	0.0%	0.0%	0.0%	0.0%	0.0%	0.0%	0.0%	0.0%	0.0%	0.0%	0.0%	0.0%	0.0%	0.0%				
Buses	0	13	0	0	13	0	0	0	3	0	0	3	0	0	0	7	1	0	8	0	0	0	4	0	0	4	0	0	28				
% Buses	0.0%	6.8%	0.0%	0.0%	0.0%	0.0%	0.0%	0.0%	3.9%	0.0%	0.0%	0.0%	0.0%	0.0%	0.0%	6.9%	6.7%	0.0%	0.0%	0.0%	0.0%	5.2%	0.0%	0.0%	0.0%	0.0%	0.0%	4.8%					
Pedestrians	0	0	0	0	0	1	0	0	0	0	0	1	1	0	0	0	0	0	0	2	2	0	0	0	0	0	1	2	0				
% Pedestrians	0.0%	0.0%	0.0%	0.0%	0.0%	100.0%	0.0%	0.0%	0.0%	0.0%	0.0%	0.0%	100.0%	100.0%	0.0%	0.0%	0.0%	0.0%	0.0%	100.0%	100.0%	0.0%	0.0%	0.0%	0.0%	0.0%	100.0%	100.0%	0.0%				
Bicycles on Crosswalk	0	0	0	0	0	0	0	0	0	0	0	0	0	0	0	0	0	0	0	0	0	0	0	0	0	0	0	0	0				
% Bicycles on Crosswalk	0.0%	0.0%	0.0%	0.0%	0.0%	0.0%	0.0%	0.0%	0.0%	0.0%	0.0%	0.0%	0.0%	0.0%	0.0%	0.0%	0.0%	0.0%	0.0%	0.0%	0.0%	0.0%	0.0%	0.0%	0.0%	0.0%	0.0%	0.0%	0.0%				

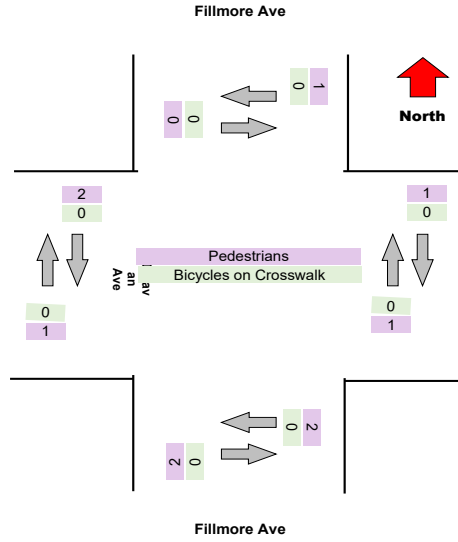
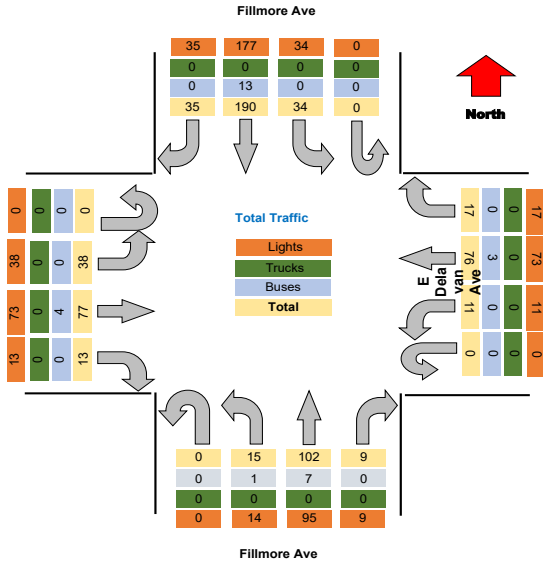

Turning Movement Peak Hour Data (PM)

4:45:00 PM

Leg Direction	Fillmore Ave					E Delavan Ave					Fillmore Ave					E Delavan Ave					Total
	Southbound					Westbound					Northbound					Eastbound					
Start Time	Right	Thru	Left	U-Turn	App Total	Peds CW	Peds CCW	Right	Thru	Left	U-Turn	App Total	Peds CW	Peds CCW	Right	Thru	Left	U-Turn	App Total	Peds CW	Peds CCW
4:45:00 PM	20	62	9	0	91	0	0	9	29	8	0	46	0	0	7	45	8	0	60	0	0
5:00:00 PM	8	65	11	0	84	0	0	11	35	9	0	55	0	0	6	66	12	0	84	1	0
5:15:00 PM	19	62	11	0	92	0	1	6	31	5	0	42	0	0	6	61	8	0	75	0	0
5:30:00 PM	12	51	9	0	72	0	0	2	31	5	0	38	0	0	5	53	8	0	66	1	0
Grand Total	59	249	40	0	329	0	1	28	128	27	0	151	0	0	24	225	36	0	285	2	0
% Approach	17.4%	79.8%	11.8%	0.0%	0.0%	0.0%	0.0%	15.5%	89.6%	14.9%	0.0%	0.0%	0.0%	0.0%	8.4%	78.9%	12.6%	0.0%	0.0%	0.0%	0.0%
% Total	5.6%	22.7%	3.8%	0.0%	32.1%	0.0%	0.0%	2.7%	11.9%	2.6%	0.0%	17.1%	0.0%	0.0%	2.3%	21.3%	3.4%	0.0%	27.0%	0.0%	0.0%
PHF	0.738	0.923	0.909	0.000	0.921	0.000	0.000	0.636	0.900	0.750	0.000	0.823	0.000	0.000	0.857	0.852	0.750	0.000	0.848	0.000	0.000
Lights	59	236	40	0	335	0	0	27	122	27	0	176	0	0	24	221	36	0	281	0	0
% Lights	100.0%	98.3%	100.0%	0.0%	98.8%	0.0%	0.0%	96.4%	96.8%	100.0%	0.0%	97.2%	0.0%	0.0%	100.0%	98.2%	100.0%	0.0%	98.6%	0.0%	0.0%
Trucks	0	0	0	0	0	0	0	0	0	0	0	0	0	0	1	0	0	0	1	0	0
% Trucks	0.0%	0.0%	0.0%	0.0%	0.0%	0.0%	0.0%	0.0%	0.0%	0.0%	0.0%	0.0%	0.0%	0.0%	0.0%	0.4%	0.0%	0.0%	0.4%	0.0%	0.0%
Buses	0	4	0	0	4	0	0	1	4	0	0	5	0	0	0	3	0	0	3	0	0
% Buses	0.0%	1.7%	0.0%	0.0%	0.0%	0.0%	0.0%	3.6%	3.2%	0.0%	0.0%	0.0%	0.0%	0.0%	0.0%	1.3%	0.0%	0.0%	0.0%	0.0%	0.0%
Pedestrians	0	0	0	0	0	1	0	0	0	0	0	0	0	2	0	0	0	0	0	2	0
% Pedestrians	0.0%	0.0%	0.0%	0.0%	0.0%	100.0%	0.0%	0.0%	0.0%	0.0%	0.0%	0.0%	0.0%	100.0%	0.0%	0.0%	0.0%	0.0%	0.0%	100.0%	100.0%
Bicycles on Crosswalk	0	0	0	0	0	0	0	0	0	0	0	0	0	0	0	0	0	0	0	0	0
% Bicycles on Crosswalk	0.0%	0.0%	0.0%	0.0%	0.0%	0.0%	0.0%	0.0%	0.0%	0.0%	0.0%	0.0%	0.0%	0.0%	0.0%	0.0%	0.0%	0.0%	0.0%	0.0%	0.0%

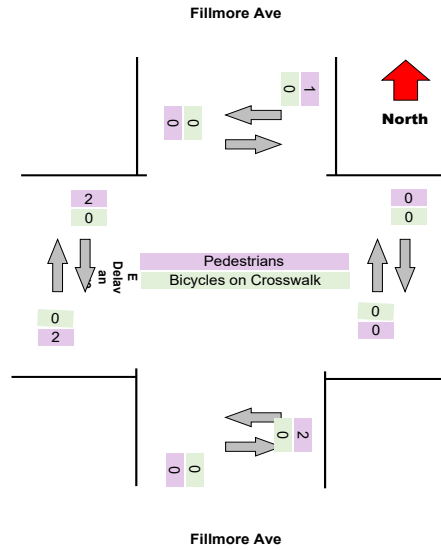
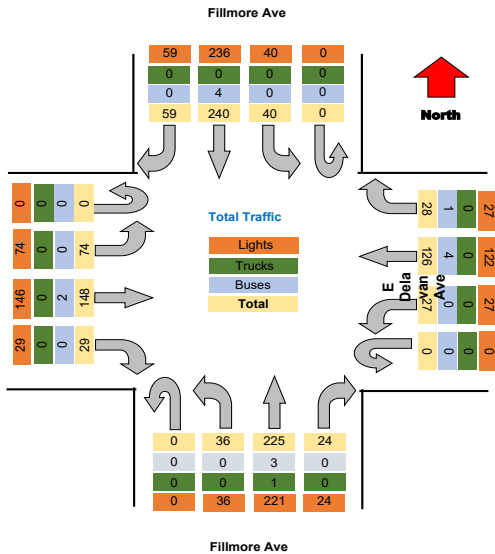

Project : VBH Malta NY
 Site : Site 4
 Location : 42.948550, -73.790036
 Survey Date : 2021-04-28, Wednesday

Turning Movement Data Plot

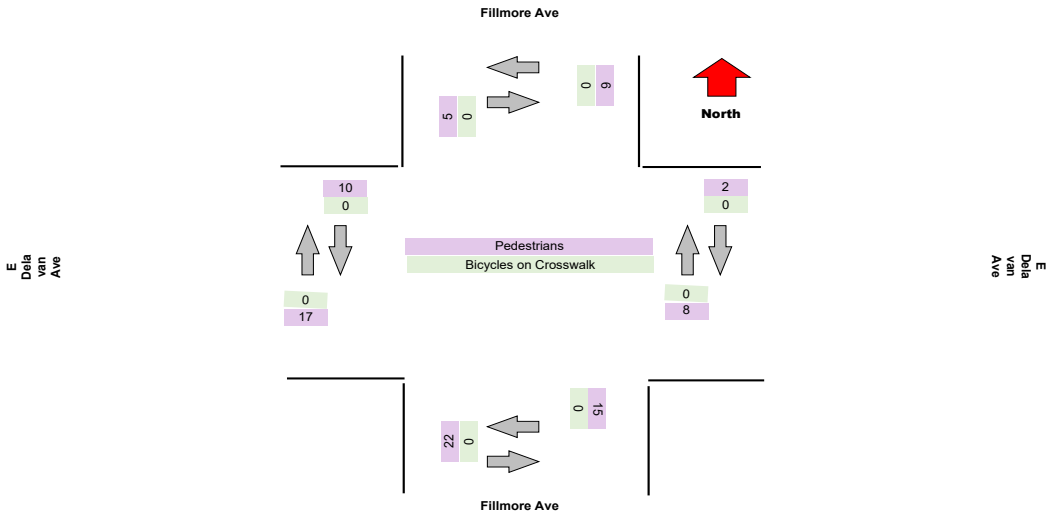
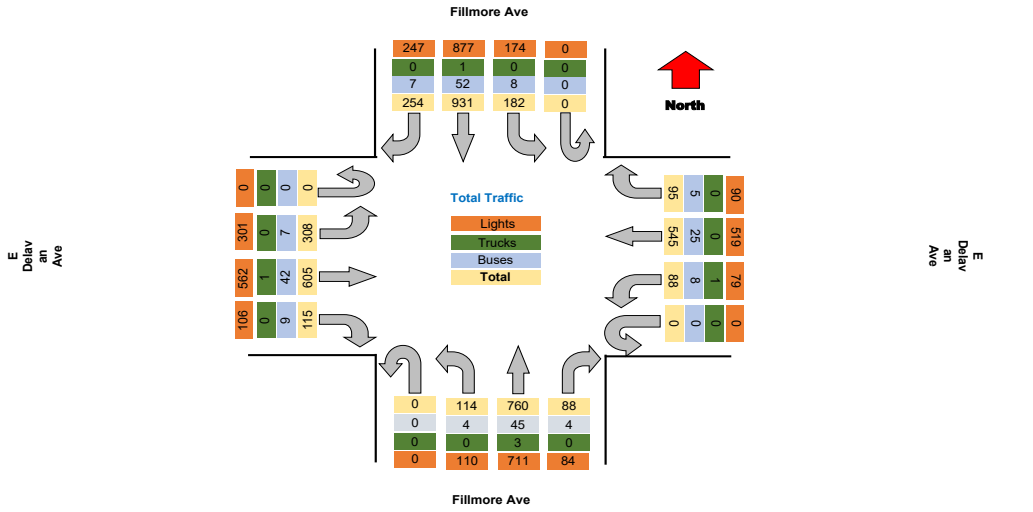

Turning Movement Peak Hour Data (AM)

7:30:00 AM

Leg Direction	Fillmore Ave							E Delavan Ave							Fillmore Ave							E Delavan Ave							Total	
	Southbound			Westbound				Northbound			Eastbound				Northbound			Eastbound												
Start Time	Right	Thru	Left	U-Turn	App Total	Peds CW	Peds CCW	Right	Thru	Left	U-Turn	App Total	Peds CW	Peds CCW	Right	Thru	Left	U-Turn	App Total	Peds CW	Peds CCW	Right	Thru	Left	U-Turn	App Total	Peds CW	Peds CCW		
7:30:00 AM	8	58	15	0	81	1	0	7	27	1	0	35	0	3	4	29	4	0	40	0	1	10	29	17	0	56	1	0	212	
7:45:00 AM	20	95	19	0	134	2	1	3	42	2	0	48	0	2	11	67	3	0	83	2	1	5	41	19	0	65	1	2	330	
8:00:00 AM	19	79	15	0	113	1	1	8	33	11	0	53	0	1	8	52	4	0	65	7	2	5	37	13	0	55	8	0	286	
8:15:00 AM	21	63	16	0	100	0	0	5	39	10	0	54	0	0	4	36	4	0	44	0	2	3	36	19	0	58	0	0	256	
Grand Total	68	295	65	0	428	4	2	23	141	24	0	190	0	6	27	194	15	0	232	3	6	23	143	68	0	234	16	2	1084	
% Approach	15.9%	68.9%	15.2%	0.0%	0.0%	0.0%	0.0%	12.1%	74.2%	12.6%	0.0%	0.0%	0.0%	0.0%	11.6%	79.3%	6.5%	0.0%	0.0%	0.0%	0.0%	9.8%	61.1%	28.1%	0.0%	0.0%	0.0%	0.0%	0.0%	
% Total	6.3%	27.2%	6.0%	0.0%	38.5%	0.0%	0.0%	2.1%	13.0%	2.2%	0.0%	17.5%	0.0%	0.0%	2.5%	17.0%	1.4%	0.0%	21.4%	0.0%	0.0%	2.1%	13.2%	6.3%	0.0%	21.6%	0.0%	0.0%	0.0%	
PHF	0.810	0.776	0.855	0.000	0.799	0.000	0.000	0.719	0.839	0.545	0.000	0.880	0.000	0.000	0.614	0.687	0.938	0.000	0.699	0.000	0.000	0.575	0.872	0.895	0.000	0.900	0.000	0.000	0.821	
Lights	65	277	63	0	405	0	0	21	133	22	0	176	0	0	24	170	14	0	208	0	0	20	136	66	0	222	0	0	1011	
% Lights	85.6%	93.9%	96.9%	0.0%	94.6%	0.0%	0.0%	81.3%	94.3%	91.7%	0.0%	92.6%	0.0%	0.0%	88.9%	92.4%	93.3%	0.0%	89.7%	0.0%	0.0%	87.0%	95.1%	97.1%	0.0%	94.9%	0.0%	0.0%	93.3%	
Trucks	0	0	0	0	0	0	0	0	0	0	0	0	0	0	0	0	0	0	0	0	0	0	0	0	0	0	0	0	0	
% Trucks	0.0%	0.0%	0.0%	0.0%	0.0%	0.0%	0.0%	0.0%	0.0%	0.0%	0.0%	0.0%	0.0%	0.0%	0.0%	0.0%	0.0%	0.0%	0.0%	0.0%	0.0%	0.0%	0.0%	0.0%	0.0%	0.0%	0.0%	0.0%	0.0%	
Buses	3	17	2	0	22	0	0	2	8	2	0	12	0	0	3	14	1	0	18	0	0	3	7	2	0	12	0	0	64	
% Buses	4.4%	5.8%	3.1%	0.0%	0.0%	0.0%	0.0%	8.7%	5.7%	8.3%	0.0%	0.0%	0.0%	0.0%	11.1%	7.8%	6.7%	0.0%	0.0%	0.0%	0.0%	13.0%	4.9%	2.9%	0.0%	0.0%	0.0%	0.0%	5.9%	
Pedestrians	0	0	0	0	0	4	2	0	0	0	0	0	6	0	0	0	0	0	0	9	6	0	0	0	0	0	10	2	0	
% Pedestrians	0.0%	0.0%	0.0%	0.0%	0.0%	100.0%	100.0%	0.0%	0.0%	0.0%	0.0%	0.0%	0.0%	0.0%	0.0%	0.0%	0.0%	0.0%	0.0%	0.0%	100.0%	100.0%	0.0%	0.0%	0.0%	0.0%	0.0%	100.0%	100.0%	0.0%
Bicycles on Crosswalk	0	0	0	0	0	0	0	0	0	0	0	0	0	0	0	0	0	0	0	0	0	0	0	0	0	0	0	0	0	
% Bicycles on Crosswalk	0.0%	0.0%	0.0%	0.0%	0.0%	0.0%	0.0%	0.0%	0.0%	0.0%	0.0%	0.0%	0.0%	0.0%	0.0%	0.0%	0.0%	0.0%	0.0%	0.0%	0.0%	0.0%	0.0%	0.0%	0.0%	0.0%	0.0%	0.0%	0.0%	

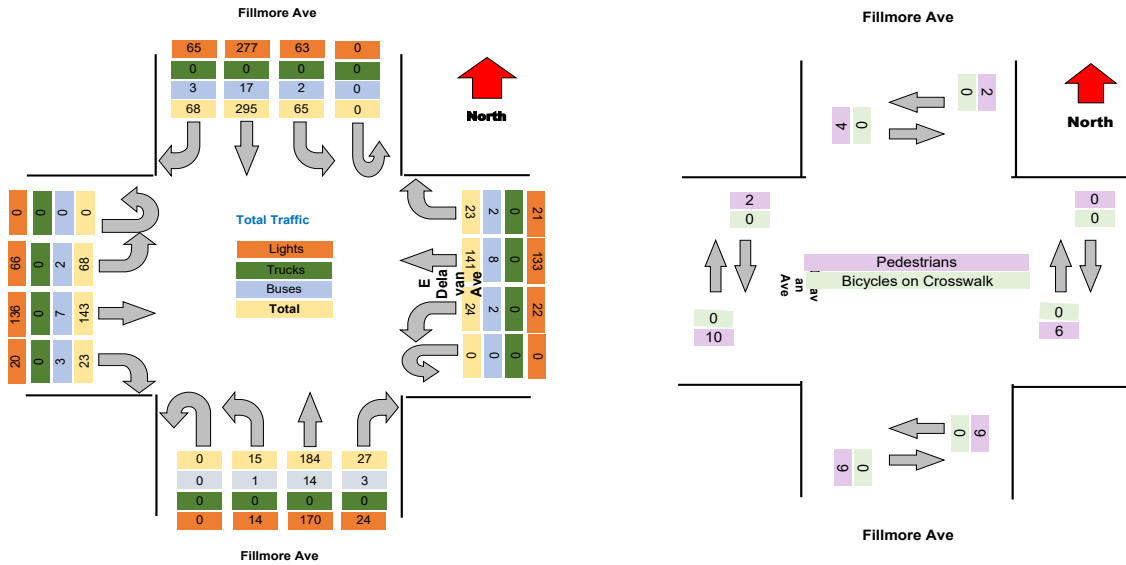

Project : VBH Malta NY
Site : Site 4
Location : 42.948550, -73.790036

TSTData.com

Survey Date : 2021-04-28, Wednesday

Turning Movement Peak Hour Data (PM)

4:45:00 PM

Leg Direction	Fillmore Ave				E Delavan Ave				Fillmore Ave				E Delavan Ave				Total						
	Southbound				Westbound				Northbound				Eastbound										
Start Time	Right	Thru	Left	U-Turn	App Total	Peds CW	Peds CCW	Right	Thru	Left	U-Turn	App Total	Peds CW	Peds CCW	Right	Thru	Left	U-Turn	App Total	Peds CW	Peds CCW	Total	
4:45:00 PM	16	52	19	0	87	1	1	8	43	11	0	62	1	1	9	72	15	0	96	0	0	343	
5:00:00 PM	18	59	8	0	85	0	0	8	40	6	0	54	0	0	2	64	6	0	72	0	0	289	
5:15:00 PM	24	70	8	0	102	0	1	6	34	5	0	45	0	0	8	62	8	0	78	1	1	300	
5:30:00 PM	8	52	14	0	75	0	0	8	43	5	0	56	0	0	6	54	11	0	71	1	1	280	
Grand Total	67	233	49	0	349	1	2	30	160	27	0	217	1	2	25	252	40	0	317	2	2	1212	
% Approach	19.2%	66.8%	14.0%	0.0%	0.0%	0.0%	0.0%	13.8%	73.7%	12.4%	0.0%	0.0%	0.0%	0.0%	7.9%	79.5%	12.6%	0.0%	0.0%	0.0%	0.0%	0.0%	
% Total	5.5%	19.2%	4.0%	0.0%	28.8%	0.0%	0.0%	2.5%	13.2%	2.2%	0.0%	17.9%	0.0%	0.0%	2.1%	20.8%	3.3%	0.0%	26.2%	0.0%	0.0%		
PHF	0.698	0.832	0.645	0.000	0.855	0.000	0.000	0.938	0.930	0.614	0.000	0.875	0.000	0.000	0.694	0.875	0.667	0.000	0.826	0.000	0.000		
Lights	66	226	47	0	339	0	0	29	156	26	0	211	0	0	24	240	39	0	303	0	0	1174	
% Lights	88.5%	97.0%	95.9%	0.0%	97.1%	0.0%	0.0%	96.7%	97.5%	96.3%	0.0%	97.2%	0.0%	0.0%	96.0%	95.2%	97.5%	0.0%	95.6%	0.0%	0.0%		
Trucks	0	0	0	0	0	0	0	0	0	0	0	0	0	0	0	1	0	0	1	0	0	1	
% Trucks	0.0%	0.0%	0.0%	0.0%	0.0%	0.0%	0.0%	0.0%	0.0%	0.0%	0.0%	0.0%	0.0%	0.0%	0.0%	0.4%	0.0%	0.0%	0.3%	0.0%	0.0%		
Buses	1	7	2	0	10	0	0	1	4	1	0	6	0	0	1	10	1	0	12	0	0	36	
% Buses	1.5%	3.0%	4.1%	0.0%	0.0%	0.0%	0.0%	3.3%	2.5%	3.7%	0.0%	0.0%	0.0%	0.0%	4.0%	4.0%	2.5%	0.0%	0.0%	0.0%	0.0%		
Pedestrians	0	0	0	0	0	1	2	0	0	0	0	0	1	1	0	0	0	0	0	2	2	0	
% Pedestrians	0.0%	0.0%	0.0%	0.0%	0.0%	100.0%	100.0%	0.0%	0.0%	0.0%	0.0%	0.0%	100.0%	100.0%	0.0%	0.0%	0.0%	0.0%	0.0%	0.6%	100.0%	100.0%	
Bicycles on Crosswalk	0	0	0	0	0	0	0	0	0	0	0	0	0	0	0	0	0	0	0	0	0	0	
% Bicycles on Crosswalk	0.0%	0.0%	0.0%	0.0%	0.0%	0.0%	0.0%	0.0%	0.0%	0.0%	0.0%	0.0%	0.0%	0.0%	0.0%	0.0%	0.0%	0.0%	0.0%	0.0%	0.0%	0.0%	

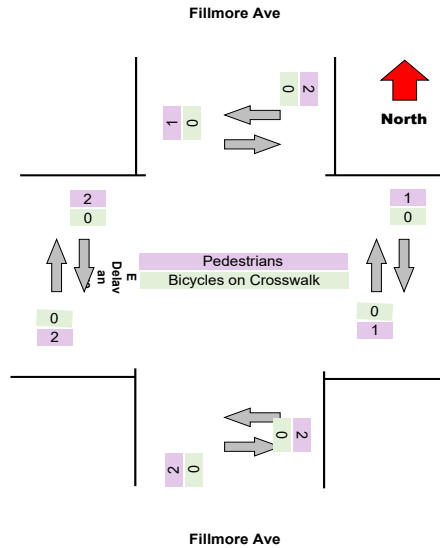
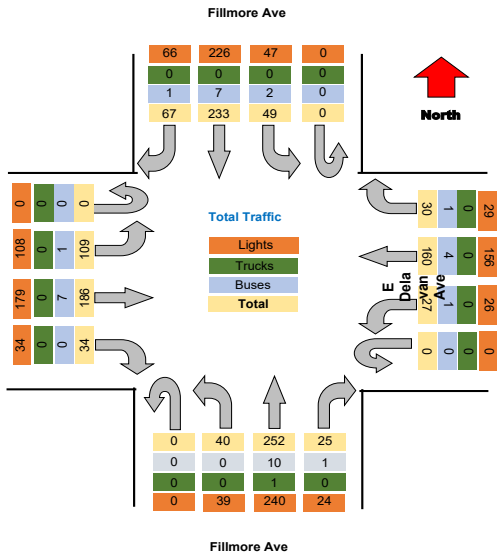

Project : VBH Malta NY
 Site : Site 4
 Location : 42.948550, -73.790036
 Survey Date : 2021-04-28, Wednesday

Turning Movement Data Plot

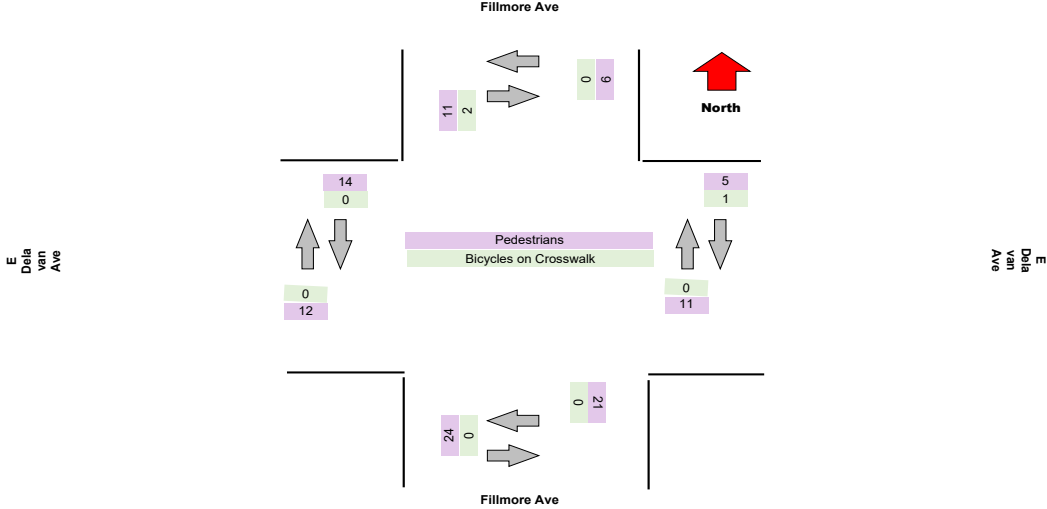
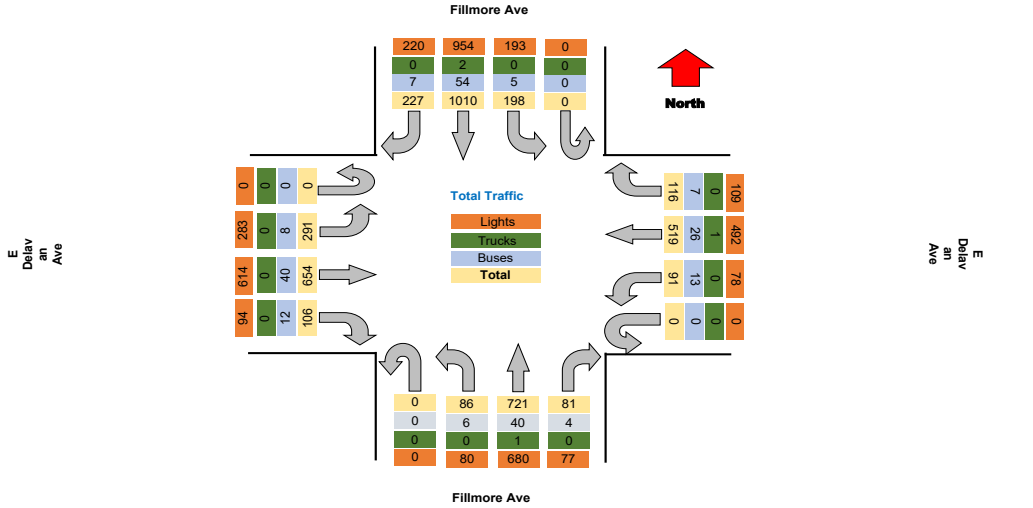

Project : VBH Malta NY
Site : Site 4
Location : 42.948550, -73.790036
Survey Date : 2021-04-28, Wednesday

TSTData.com

Turning Movement Peak Hour Data (AM)

7:30:00 AM

Leg Direction	Fillmore Ave						E Delavan Ave						Fillmore Ave						E Delavan Ave						Total				
	Southbound			Northbound			Westbound			Eastbound			Northbound			Eastbound													
Start Time	Right	Thru	Left	U-Turn	App Total	Peds CW	Peds CCW	Right	Thru	Left	U-Turn	App Total	Peds CW	Peds CCW	Right	Thru	Left	U-Turn	App Total	Peds CW	Peds CCW	Right	Thru	Left	U-Turn	App Total	Peds CW	Peds CCW	
7:30:00 AM	6	73	13	0	92	2	1	4	32	5	0	42	0	0	2	30	3	0	35	1	2	5	33	23	0	61	1	1	230
7:45:00 AM	22	82	18	0	122	1	0	7	32	3	0	42	0	0	6	42	4	0	52	0	5	1	26	11	0	38	1	4	254
8:00:00 AM	19	74	17	0	110	0	0	5	37	8	0	50	1	1	9	39	4	0	54	0	0	6	54	24	0	84	1	0	298
8:15:00 AM	14	70	11	0	95	1	0	11	30	9	0	53	1	7	5	52	5	0	70	7	4	5	34	16	0	55	2	1	273
Grand Total	61	299	59	0	419	4	1	27	131	25	0	187	2	8	22	183	16	0	211	3	11	17	147	74	0	238	3	6	1055
% Approach	14.6%	71.4%	14.1%	0.0%	0.0%	0.0%	0.0%	14.4%	70.1%	13.4%	0.0%	0.0%	0.0%	0.0%	10.4%	77.3%	7.6%	0.0%	0.0%	0.0%	0.0%	7.1%	61.8%	31.1%	0.0%	0.0%	0.0%	0.0%	0.0%
% Total	5.8%	28.3%	5.6%	0.0%	38.7%	0.0%	0.0%	2.6%	12.4%	2.4%	0.0%	17.7%	0.0%	0.0%	2.1%	15.5%	1.5%	0.0%	20.0%	0.0%	0.0%	1.6%	13.9%	7.0%	0.0%	22.6%	0.0%	0.0%	0.0%
PHF	0.693	0.912	0.619	0.000	0.859	0.000	0.000	0.614	0.885	0.694	0.000	0.882	0.000	0.000	0.611	0.784	0.800	0.000	0.754	0.000	0.000	0.708	0.681	0.771	0.000	0.708	0.000	0.000	0.885
Lights	58	279	59	0	396	0	0	26	123	23	0	172	0	0	20	150	13	0	183	0	0	14	143	69	0	226	0	0	977
% Lights	85.1%	93.3%	100.0%	0.0%	94.5%	0.0%	0.0%	86.3%	93.9%	92.0%	0.0%	92.0%	0.0%	0.0%	80.9%	92.0%	81.3%	0.0%	86.7%	0.0%	0.0%	82.4%	97.3%	93.2%	0.0%	95.0%	0.0%	0.0%	92.6%
Trucks	0	0	0	0	0	0	0	0	0	0	0	0	0	0	0	0	0	0	0	0	0	0	0	0	0	0	0	0	0
% Trucks	0.0%	0.0%	0.0%	0.0%	0.0%	0.0%	0.0%	0.0%	0.0%	0.0%	0.0%	0.0%	0.0%	0.0%	0.0%	0.0%	0.0%	0.0%	0.0%	0.0%	0.0%	0.0%	0.0%	0.0%	0.0%	0.0%	0.0%	0.0%	0.0%
Buses	3	20	0	0	23	0	0	1	8	2	0	11	0	0	2	13	3	0	18	0	0	3	4	5	0	12	0	0	64
% Buses	4.9%	6.7%	0.0%	0.0%	0.0%	0.0%	0.0%	3.7%	6.1%	8.0%	0.0%	0.0%	0.0%	0.0%	9.1%	8.0%	18.8%	0.0%	0.0%	0.0%	0.0%	17.6%	2.7%	6.8%	0.0%	0.0%	0.0%	0.0%	6.1%
Pedestrians	0	0	0	0	0	4	4	0	0	0	0	2	6	8	0	0	0	0	8	11	0	0	0	0	0	0	5	6	0
% Pedestrians	0.0%	0.0%	0.0%	0.0%	0.0%	100.0%	100.0%	0.0%	0.0%	0.0%	0.0%	0.0%	100.0%	100.0%	0.0%	0.0%	0.0%	0.0%	0.0%	0.0%	0.0%	0.0%	0.0%	0.0%	0.0%	0.0%	0.0%	0.0%	0.0%
Bicycles on Crosswalk	0	0	0	0	0	0	0	0	0	0	0	0	0	0	0	0	0	0	0	0	0	0	0	0	0	0	0	0	0
% Bicycles on Crosswalk	0.0%	0.0%	0.0%	0.0%	0.0%	0.0%	0.0%	0.0%	0.0%	0.0%	0.0%	0.0%	0.0%	0.0%	0.0%	0.0%	0.0%	0.0%	0.0%	0.0%	0.0%	0.0%	0.0%	0.0%	0.0%	0.0%	0.0%	0.0%	0.0%

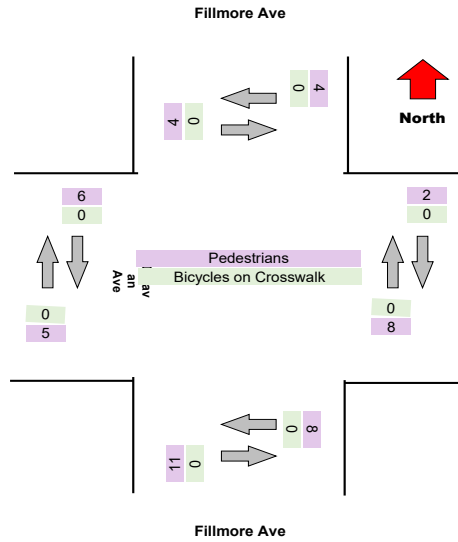
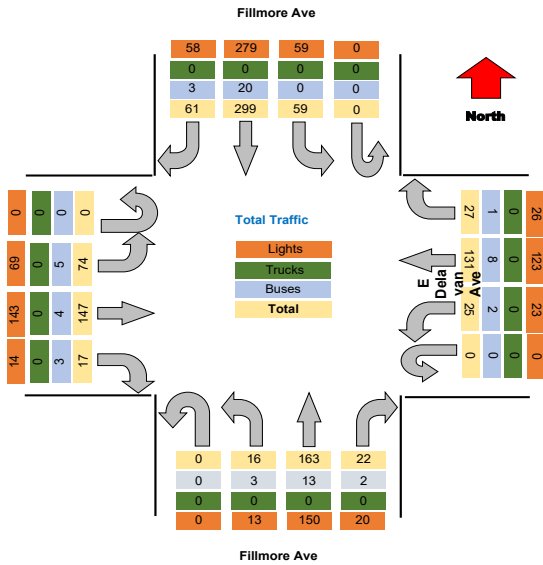

Turning Movement Peak Hour Data (PM)

4:45:00 PM

Leg Direction	Fillmore Ave										E Delavan Ave										Fillmore Ave										E Delavan Ave										Total
	Southbound					Westbound					Northbound					Eastbound																									
	Right	Thru	Left	U-Turn	App Total	Right	Thru	Left	U-Turn	App Total	Right	Thru	Left	U-Turn	App Total	Right	Thru	Left	U-Turn	App Total																					
4:45:00 PM	20	71	13	0	104	12	43	11	0	66	13	80	5	0	98	12	53	24	0	89	357																				
5:00:00 PM	15	72	18	0	105	10	30	6	0	46	2	70	6	0	78	6	42	25	0	73	302																				
5:15:00 PM	8	78	12	0	98	7	43	6	0	56	9	63	12	0	84	13	42	18	0	73	311																				
5:30:00 PM	20	59	9	0	88	8	34	6	0	48	4	58	9	0	72	11	48	17	0	76	284																				
Grand Total	63	289	52	0	395	37	150	29	0	216	28	272	32	0	332	42	185	84	0	311	1284																				
% Approach	15.9%	70.9%	13.2%	0.0%	0.0%	17.1%	69.4%	13.4%	0.0%	0.0%	8.4%	81.6%	9.6%	0.0%	0.0%	13.5%	59.5%	27.0%	0.0%	0.0%																					
% Total	5.0%	22.3%	4.1%	0.0%	31.5%	3.0%	12.0%	2.3%	0.0%	17.2%	2.2%	21.7%	2.6%	0.0%	26.5%	3.3%	14.8%	6.7%	0.0%	24.8%																					
PHF	0.788	0.897	0.722	0.000	0.940	0.771	0.872	0.659	0.000	0.818	0.538	0.850	0.667	0.000	0.847	0.808	0.873	0.840	0.000	0.874	0.878																				
Lights	61	271	51	0	383	35	145	27	0	207	27	264	30	0	321	40	180	84	0	304	1215																				
% Lights	96.8%	96.8%	98.1%	0.0%	97.0%	94.6%	96.7%	93.1%	0.0%	95.8%	96.4%	97.1%	93.8%	0.0%	96.7%	95.2%	97.3%	100.0%	0.0%	97.7%	96.9%																				
Trucks	0	1	0	0	1	0	0	0	0	0	0	1	0	0	1	0	0	0	0	0	2																				
% Trucks	0.0%	0.4%	0.0%	0.0%	0.3%	0.0%	0.0%	0.0%	0.0%	0.0%	0.0%	0.4%	0.0%	0.0%	0.3%	0.0%	0.0%	0.0%	0.0%	0.0%	0.2%																				
Buses	2	8	1	0	11	2	5	2	0	9	1	7	2	0	10	2	5	0	0	7	37																				
% Buses	3.2%	2.9%	1.9%	0.0%	0.0%	5.4%	3.3%	6.9%	0.0%	0.0%	3.6%	2.6%	6.3%	0.0%	0.0%	4.8%	2.7%	0.0%	0.0%	0.0%	3.0%																				
Pedestrians	0	0	0	0	0	0	0	0	0	0	0	0	0	0	0	0	0	0	0	0	0																				
% Pedestrians	0.0%	0.0%	0.0%	0.0%	0.0%	0.0%	0.0%	0.0%	0.0%	0.0%	0.0%	0.0%	0.0%	0.0%	0.0%	0.0%	0.0%	0.0%	0.0%	0.0%	0.0%																				
Bicycles on Crosswalk	0	0	0	0	0	0	0	0	0	0	0	0	0	0	0	0	0	0	0	0	0																				
% Bicycles on Crosswalk	0.0%	0.0%	0.0%	0.0%	0.0%	0.0%	0.0%	0.0%	0.0%	0.0%	0.0%	0.0%	0.0%	0.0%	0.0%	0.0%	0.0%	0.0%	0.0%	0.0%	0.0%																				

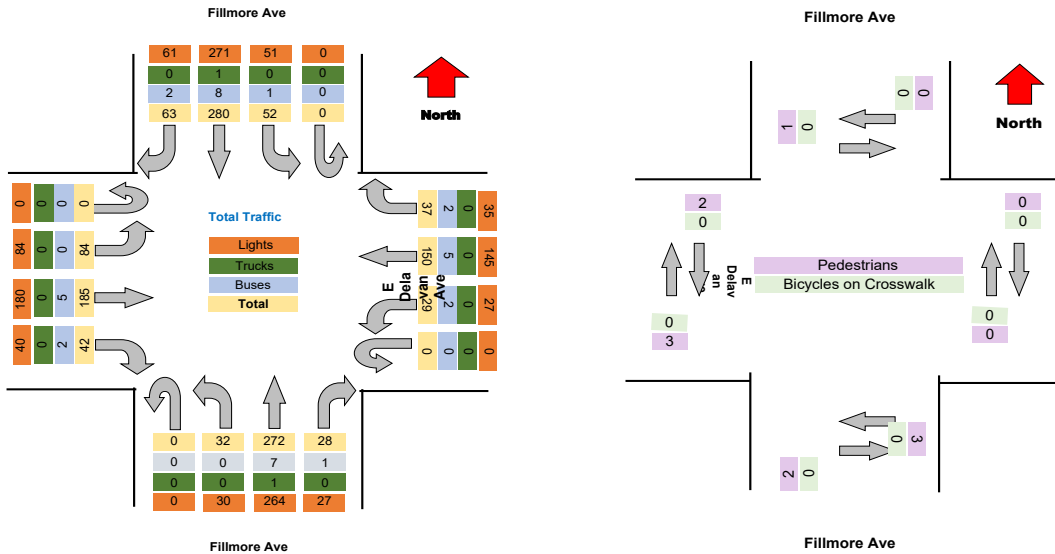

Project : VBH Malta NY
 Site : Site 4
 Location : 42.948550, -73.790036
 Survey Date : 2021-04-28, Wednesday

Turning Movement Data Plot

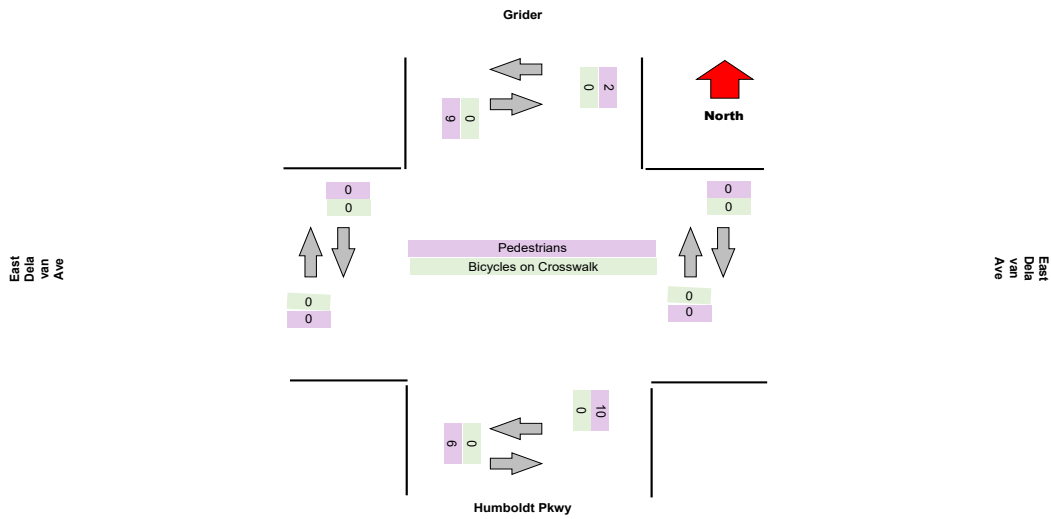
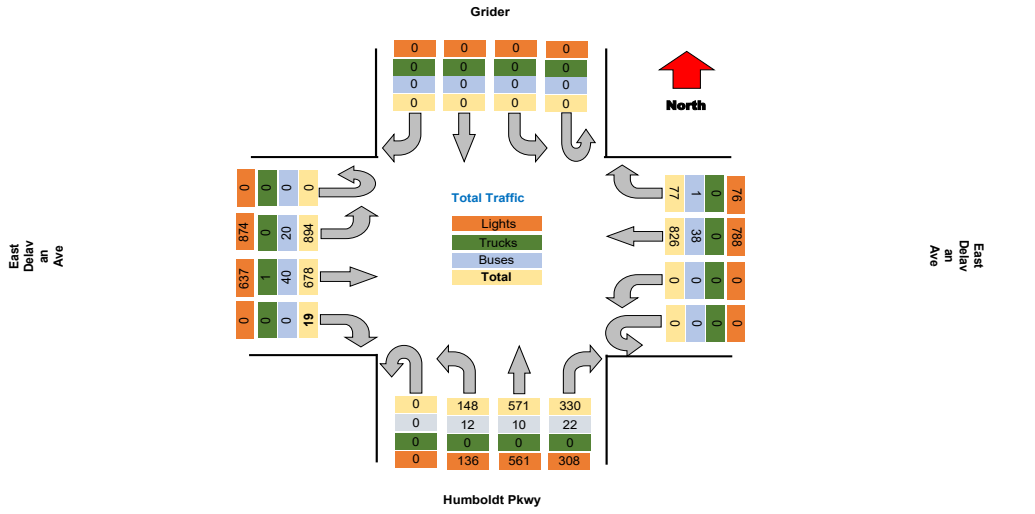

Project : VBH Malta NY
Site : Site 4
Location : 42.948550, -73.790036

TSTData.com

Survey Date : 2021-04-28, Wednesday

Turning Movement Peak Hour Data (AM)

7:30:00 AM

Leg Direction	Grider								East Delavan Ave								Humboldt Pkwy								East Delavan Ave								Total
	Southbound				Westbound				Northbound				Eastbound				Northbound				Eastbound												
Start Time	Right	Thru	Left	U-Turn	App Total	Peds CW	Peds CCW		Right	Thru	Left	U-Turn	App Total	Peds CW	Peds CCW		Right	Thru	Left	U-Turn	App Total	Peds CW	Peds CCW		Right	Thru	Left	U-Turn	App Total	Peds CW	Peds CCW		
7:30:00 AM	0	0	0	0	0	0	0		4	44	0	0	48	0	0		19	30	8	0	57	0	1		0	31	73	0	104	0	0		209
7:45:00 AM	0	0	0	0	0	0	0		7	50	0	0	57	0	0		33	32	4	0	69	0	2		0	47	62	0	109	0	0		235
8:00:00 AM	0	0	0	0	0	0	2		6	69	0	0	77	0	0		22	36	7	0	65	1	0		0	41	57	0	98	0	0		240
8:15:00 AM	0	0	0	0	0	0	0		4	55	0	0	59	0	0		14	37	15	0	66	0	1		0	50	71	0	121	0	0		246
Grand Total	0	0	0	0	0	0	2		21	218	0	0	241	0	0		85	135	34	0	257	1	4		0	159	263	0	432	0	0		930
% Approach	#DIV/0!	#DIV/0!	#DIV/0!	#DIV/0!	0.0%	0.0%	0.0%		14.2%	85.8%	0.0%	0.0%	0.0%	0.0%	0.0%		45.1%	41.7%	13.2%	0.0%	0.0%	0.0%	0.0%		0.0%	66.2%	33.8%	0.0%	0.0%	0.0%	0.0%		
% Total	0.0%	0.0%	0.0%	0.0%	0.0%	0.0%	0.0%		2.3%	23.4%	0.0%	0.0%	25.9%	0.0%	0.0%		9.5%	14.5%	3.7%	0.0%	27.6%	0.0%	0.0%		0.0%	18.2%	28.3%	0.0%	46.5%	0.0%	0.0%		
PHF	0.000	0.000	0.000	0.000	0.000	0.000	0.000		0.750	0.790	0.000	0.000	0.782	0.000	0.000		0.667	0.912	0.567	0.000	0.831	0.000	0.000		0.000	0.845	0.901	0.000	0.893	0.000	0.000		0.845
Lights	0	0	0	0	0	0	0		21	207	0	0	228	0	0		85	131	31	0	247	0	0		0	162	258	0	420	0	0		895
% Lights	0.0%	0.0%	0.0%	0.0%	0.0%	0.0%	0.0%		100.0%	95.0%	0.0%	0.0%	94.6%	0.0%	0.0%		86.6%	97.0%	91.2%	0.0%	96.1%	0.0%	0.0%		0.0%	95.9%	98.1%	0.0%	97.2%	0.0%	0.0%		
Trucks	0	0	0	0	0	0	0		0	0	0	0	0	0	0		0	0	0	0	0	0	0		0	1	0	0	1	0	0		1
% Trucks	0.0%	0.0%	0.0%	0.0%	0.0%	0.0%	0.0%		0.0%	0.0%	0.0%	0.0%	0.0%	0.0%	0.0%		0.0%	0.0%	0.0%	0.0%	0.0%	0.0%	0.0%		0.0%	0.6%	0.0%	0.0%	0.2%	0.0%	0.0%		
Buses	0	0	0	0	0	0	0		0	11	0	0	11	0	0		3	4	3	0	10	0	0		0	6	5	0	11	0	0		32
% Buses	0.0%	0.0%	0.0%	0.0%	0.0%	0.0%	0.0%		0.0%	5.0%	0.0%	0.0%	0.0%	0.0%	0.0%		3.4%	3.0%	8.8%	0.0%	0.0%	0.0%	0.0%		0.0%	3.8%	1.9%	0.0%	0.0%	0.0%	0.0%		3.4%
Pedestrians	0	0	0	0	0	0	2		0	0	0	0	0	0	0		0	0	0	0	1	4	0		0	0	0	0	0	0	0		0
% Pedestrians	0.0%	0.0%	0.0%	0.0%	0.0%	0.0%	100.0%		0.0%	0.0%	0.0%	0.0%	0.0%	0.0%	0.0%		0.0%	0.0%	0.0%	0.0%	0.0%	100.0%	100.0%		0.0%	0.0%	0.0%	0.0%	0.0%	0.0%	0.0%		0.0%
Bicycles on Crosswalk	0	0	0	0	0	0	0		0	0	0	0	0	0	0		0	0	0	0	0	0	0		0	0	0	0	0	0	0		0
% Bicycles on Crosswalk	0.0%	0.0%	0.0%	0.0%	0.0%	0.0%	0.0%		0.0%	0.0%	0.0%	0.0%	0.0%	0.0%	0.0%		0.0%	0.0%	0.0%	0.0%	0.0%	0.0%	0.0%		0.0%	0.0%	0.0%	0.0%	0.0%	0.0%	0.0%		0.0%

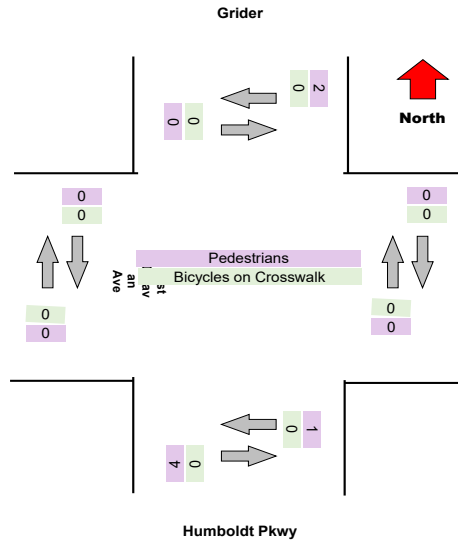
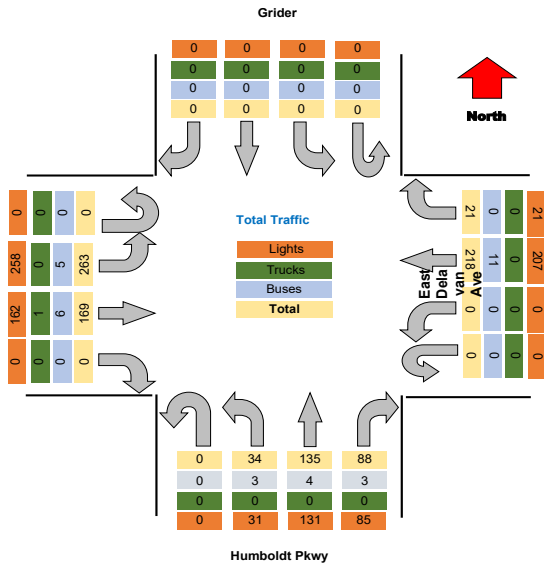

Turning Movement Peak Hour Data (PM)

4:30:00 PM

Leg Direction	Grider										East Delavan Ave										Total					
	Southbound					Westbound					Northbound					Eastbound										
	Right	Thru	Left	U-Turn	App Total	Right	Thru	Left	U-Turn	App Total	Right	Thru	Left	U-Turn	App Total	Right	Thru	Left	U-Turn	App Total						
4:30:00 PM	0	0	0	0	0	4	71	0	0	75	31	39	6	0	76	1	1	0	0	2	0	81	55	0	136	287
4:45:00 PM	0	0	0	0	0	5	69	0	0	74	23	31	14	0	68	2	0	0	0	2	0	59	45	0	104	246
5:00:00 PM	0	0	0	0	0	3	53	0	0	56	25	47	7	0	79	0	0	0	0	0	0	57	51	0	88	233
5:15:00 PM	0	0	0	0	0	7	55	0	0	62	29	39	13	0	81	1	0	0	0	1	0	50	74	0	124	267
Grand Total	0	0	0	0	0	19	258	0	0	277	108	155	40	0	303	4	1	0	0	5	0	227	225	0	452	1033
% Approach	#DIV/0!	#DIV/0!	#DIV/0!	#DIV/0!	0.0%	14.2%	85.8%	0.0%	0.0%	0.0%	45.1%	41.7%	13.2%	0.0%	0.0%	0.0%	65.2%	33.8%	0.0%	0.0%	0.0%	0.0%	0.0%	0.0%	0.0%	
% Total	0.0%	0.0%	0.0%	0.0%	0.0%	1.8%	25.0%	0.0%	0.0%	26.8%	10.5%	15.1%	3.9%	0.0%	29.4%	0.0%	22.0%	21.8%	0.0%	43.8%	0.0%	0.0%	0.0%	0.0%	0.0%	
PHF	0.000	0.000	0.000	0.000	0.000	0.679	0.908	0.000	0.000	0.923	0.871	0.830	0.714	0.000	0.938	0.000	0.701	0.760	0.000	0.831	0.000	0.000	0.000	0.000	0.900	
Lights	0	0	0	0	0	19	250	0	0	269	108	153	40	0	301	0	0	0	0	0	0	216	222	0	438	1008
% Lights	0.0%	0.0%	0.0%	0.0%	0.0%	100.0%	96.9%	0.0%	0.0%	97.1%	100.0%	98.1%	100.0%	0.0%	99.0%	0.0%	95.2%	98.7%	0.0%	96.9%	0.0%	0.0%	0.0%	0.0%	97.6%	
Trucks	0	0	0	0	0	0	0	0	0	0	0	0	0	0	0	0	0	0	0	0	0	0	0	0	0	0
% Trucks	0.0%	0.0%	0.0%	0.0%	0.0%	0.0%	0.0%	0.0%	0.0%	0.0%	0.0%	0.0%	0.0%	0.0%	0.0%	0.0%	0.0%	0.0%	0.0%	0.0%	0.0%	0.0%	0.0%	0.0%	0.0%	
Buses	0	0	0	0	0	0	8	0	0	8	0	3	0	0	3	0	0	0	0	0	0	11	3	0	14	25
% Buses	0.0%	0.0%	0.0%	0.0%	0.0%	0.0%	3.1%	0.0%	0.0%	0.0%	0.0%	1.9%	0.0%	0.0%	0.0%	0.0%	4.8%	1.3%	0.0%	0.0%	0.0%	0.0%	0.0%	0.0%	2.4%	
Pedestrians	0	0	0	0	5	0	0	0	0	0	0	0	0	0	4	1	0	0	0	1	0	0	0	0	0	0
% Pedestrians	0.0%	0.0%	0.0%	0.0%	100.0%	0.0%	0.0%	0.0%	0.0%	0.0%	0.0%	0.0%	0.0%	0.0%	0.0%	100.0%	100.0%	0.0%	0.0%	0.0%	0.0%	0.0%	0.0%	0.0%	0.0%	
Bicycles on Crosswalk	0	0	0	0	0	0	0	0	0	0	0	0	0	0	0	0	0	0	0	0	0	0	0	0	0	0
% Bicycles on Crosswalk	0.0%	0.0%	0.0%	0.0%	0.0%	0.0%	0.0%	0.0%	0.0%	0.0%	0.0%	0.0%	0.0%	0.0%	0.0%	0.0%	0.0%	0.0%	0.0%	0.0%	0.0%	0.0%	0.0%	0.0%	0.0%	

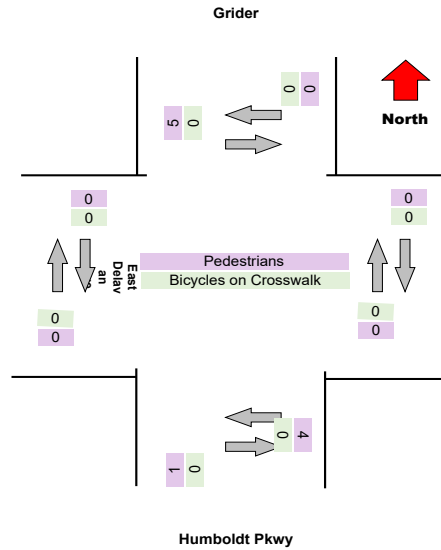
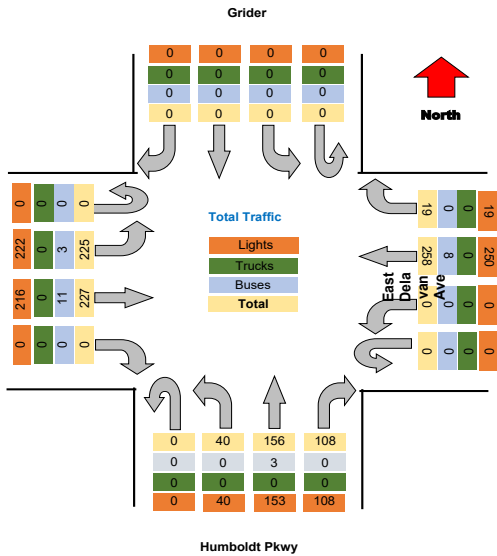

Turning Movement Data Plot

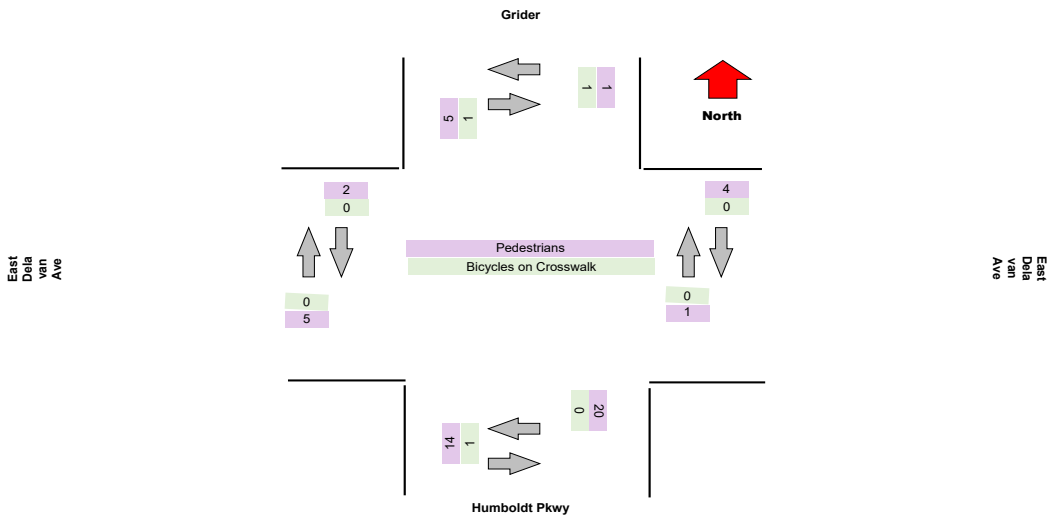
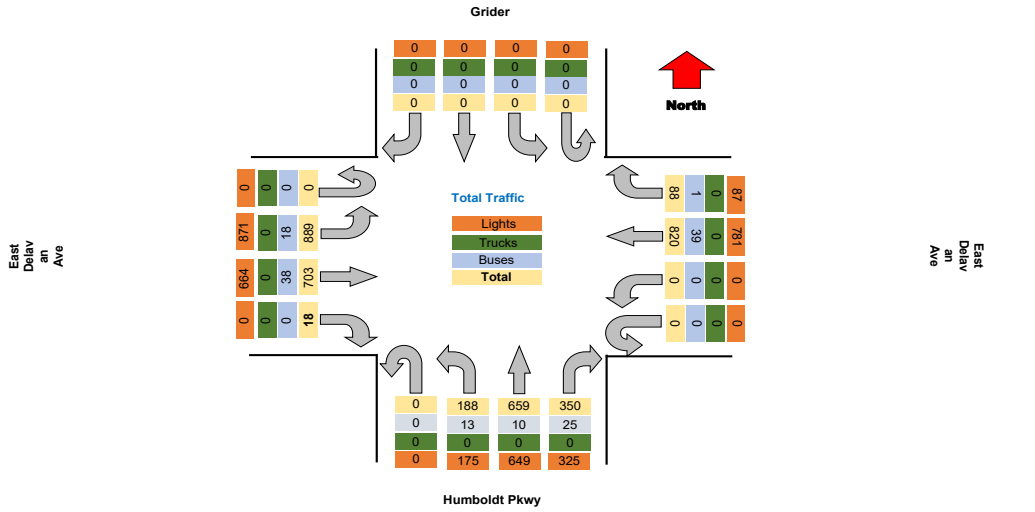

Turning Movement Peak Hour Data (AM)

7:30:00 AM

Leg Direction	Grider										East Delavan Ave										Humboldt Pkwy										East Delavan Ave										Total
	Southbound					Westbound					Northbound					Eastbound					Northbound					Eastbound															
	Right	Thru	Left	U-Turn	App Total	Right	Thru	Left	U-Turn	App Total	Right	Thru	Left	U-Turn	App Total	Right	Thru	Left	U-Turn	App Total	Right	Thru	Left	U-Turn	App Total	Right	Thru	Left	U-Turn	App Total											
7:30:00 AM	0	0	0	0	0	4	38	0	0	43	18	41	10	0	69	0	23	73	0	96	0	0	0	0	0	0	23	73	0	96											
7:45:00 AM	0	0	0	0	0	5	54	0	0	59	19	34	11	0	65	0	46	67	0	113	0	0	0	0	0	0	46	67	0	113											
8:00:00 AM	0	0	0	0	0	6	53	0	0	59	27	36	13	0	76	0	45	49	0	94	0	0	0	0	0	0	45	49	0	94											
8:15:00 AM	0	0	0	0	0	1	47	0	0	48	6	36	10	0	51	0	35	65	0	100	0	0	0	0	0	0	35	65	0	100											
Grand Total	0	0	0	0	0	16	192	0	0	209	70	146	44	0	251	0	149	254	0	403	0	0	0	0	0	0	149	254	0	403											
% Approach	#DIV/0!	#DIV/0!	#DIV/0!	#DIV/0!	0.0%	14.2%	85.8%	0.0%	0.0%	0.0%	45.1%	41.7%	13.2%	0.0%	0.0%	0.0%	66.2%	33.8%	0.0%	0.0%	0.0%	17.1%	29.1%	0.0%	46.2%	0.0%	0.0%	0.0%	0.0%	0.0%											
% Total	0.0%	0.0%	0.0%	0.0%	0.0%	1.8%	22.0%	0.0%	0.0%	23.9%	8.0%	16.7%	5.0%	0.0%	29.9%	0.0%	17.1%	29.1%	0.0%	46.2%	0.0%	0.0%	0.0%	0.0%	0.0%	0.0%	17.1%	29.1%	0.0%	46.2%											
PHF	0.000	0.000	0.000	0.000	0.000	0.667	0.889	0.000	0.000	0.886	0.648	0.890	0.846	0.000	0.859	0.000	0.000	0.000	0.000	0.000	0.000	0.810	0.870	0.000	0.892	0.000	0.000	0.000	0.000	0.000											
Lights	0	0	0	0	0	16	178	0	0	194	69	140	41	0	250	0	139	251	0	390	0	0	0	0	0	0	139	251	0	390											
% Lights	0.0%	0.0%	0.0%	0.0%	0.0%	100.0%	92.7%	0.0%	0.0%	92.8%	88.6%	95.9%	93.2%	0.0%	95.8%	0.0%	93.3%	98.8%	0.0%	96.8%	0.0%	0.0%	0.0%	0.0%	0.0%	0.0%	93.3%	98.8%	0.0%	96.8%											
Trucks	0	0	0	0	0	0	0	0	0	0	0	0	0	0	0	0	0	0	0	0	0	0	0	0	0	0	0	0	0	0											
% Trucks	0.0%	0.0%	0.0%	0.0%	0.0%	0.0%	0.0%	0.0%	0.0%	0.0%	0.0%	0.0%	0.0%	0.0%	0.0%	0.0%	0.0%	0.0%	0.0%	0.0%	0.0%	0.0%	0.0%	0.0%	0.0%	0.0%	0.0%	0.0%	0.0%	0.0%											
Buses	0	0	0	0	0	0	14	0	0	14	1	6	3	0	10	0	10	3	0	13	0	0	0	0	0	0	10	3	0	13											
% Buses	0.0%	0.0%	0.0%	0.0%	0.0%	0.0%	7.3%	0.0%	0.0%	0.0%	1.4%	4.1%	6.8%	0.0%	0.0%	0.0%	6.7%	1.2%	0.0%	0.0%	0.0%	0.0%	0.0%	0.0%	0.0%	0.0%	6.7%	1.2%	0.0%	0.0%											
Pedestrians	0	0	0	0	0	0	0	0	0	0	0	0	0	0	0	0	0	0	0	0	0	0	0	0	0	0	0	0	0	0											
% Pedestrians	0.0%	0.0%	0.0%	0.0%	0.0%	0.0%	0.0%	0.0%	0.0%	0.0%	0.0%	0.0%	0.0%	0.0%	0.0%	0.0%	0.0%	0.0%	0.0%	0.0%	0.0%	0.0%	0.0%	0.0%	0.0%	0.0%	0.0%	0.0%	0.0%	0.0%											
Bicycles on Crosswalk	0	0	0	0	0	0	0	0	0	0	0	0	0	0	0	0	0	0	0	0	0	0	0	0	0	0	0	0	0	0											
% Bicycles on Crosswalk	0.0%	0.0%	0.0%	0.0%	0.0%	0.0%	0.0%	0.0%	0.0%	0.0%	0.0%	0.0%	0.0%	0.0%	0.0%	0.0%	0.0%	0.0%	0.0%	0.0%	0.0%	0.0%	0.0%	0.0%	0.0%	0.0%	0.0%	0.0%	0.0%	0.0%											

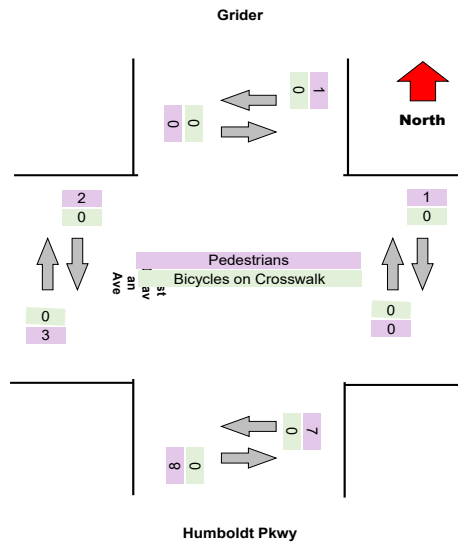
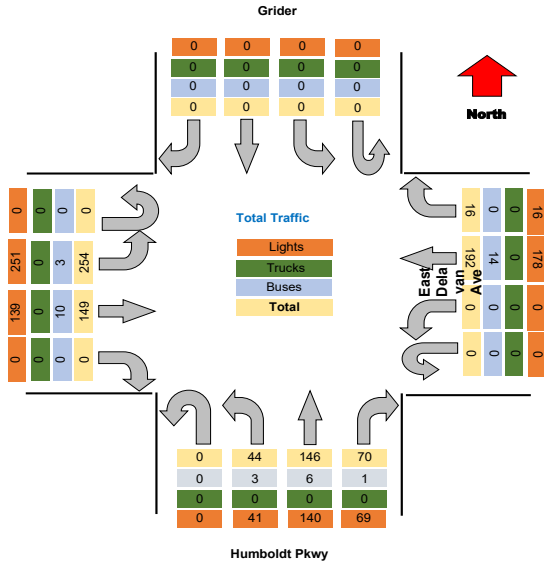

Turning Movement Peak Hour Data (PM)

4:30:00 PM

Leg Direction	Grider										East Delavan Ave										Total					
	Southbound					Westbound					Northbound					Eastbound										
	Right	Thru	Left	U-Turn	App Total	Right	Thru	Left	U-Turn	App Total	Right	Thru	Left	U-Turn	App Total	Right	Thru	Left	U-Turn	App Total						
4:30:00 PM	0	0	0	0	0	6	65	0	0	71	44	48	19	0	111	4	1	0	0	5	0	73	50	0	123	305
4:45:00 PM	0	0	0	0	0	9	68	0	0	77	29	46	10	0	85	1	0	0	0	1	0	68	53	0	121	283
5:00:00 PM	0	0	0	0	0	7	52	0	0	59	22	50	13	0	85	0	0	0	0	0	0	48	48	0	96	250
5:15:00 PM	0	0	0	0	0	6	54	0	0	60	31	56	22	0	109	1	0	0	0	1	0	50	50	0	100	279
Grand Total	0	0	0	0	0	28	249	0	0	277	125	200	64	0	389	6	1	0	0	7	0	229	210	0	439	1117
% Approach	#DIV/0!	#DIV/0!	#DIV/0!	#DIV/0!	0.0%	14.2%	85.8%	0.0%	0.0%	0.0%	45.1%	41.7%	13.2%	0.0%	0.0%	0.0%	66.2%	33.8%	0.0%	0.0%	0.0%	66.2%	33.8%	0.0%	0.0%	
% Total	0.0%	0.0%	0.0%	0.0%	0.0%	2.5%	22.3%	0.0%	0.0%	24.8%	11.3%	17.9%	5.7%	0.0%	34.9%	0.0%	21.4%	18.9%	0.0%	40.3%	0.0%	21.4%	18.9%	0.0%	40.3%	
PHF	0.000	0.000	0.000	0.000	0.000	0.778	0.915	0.000	0.000	0.899	0.716	0.893	0.727	0.000	0.878	0.000	0.818	0.879	0.000	0.915	0.000	0.818	0.879	0.000	0.915	
Lights	0	0	0	0	0	28	240	0	0	268	125	196	64	0	385	0	0	0	0	0	0	229	210	0	439	
% Lights	0.0%	0.0%	0.0%	0.0%	0.0%	100.0%	96.4%	0.0%	0.0%	96.8%	99.2%	98.0%	100.0%	0.0%	98.7%	0.0%	95.8%	99.5%	0.0%	97.6%	0.0%	95.8%	99.5%	0.0%	97.6%	
Trucks	0	0	0	0	0	0	0	0	0	0	0	0	0	0	0	0	0	0	0	0	0	0	0	0	0	
% Trucks	0.0%	0.0%	0.0%	0.0%	0.0%	0.0%	0.0%	0.0%	0.0%	0.0%	0.0%	0.0%	0.0%	0.0%	0.0%	0.0%	0.0%	0.0%	0.0%	0.0%	0.0%	0.0%	0.0%	0.0%	0.0%	
Buses	0	0	0	0	0	0	9	0	0	9	1	4	0	0	5	0	10	1	0	11	0	10	1	0	11	
% Buses	0.0%	0.0%	0.0%	0.0%	0.0%	0.0%	3.6%	0.0%	0.0%	0.0%	0.8%	2.0%	0.0%	0.0%	0.0%	0.0%	4.2%	0.5%	0.0%	0.0%	0.0%	4.2%	0.5%	0.0%	0.0%	
Pedestrians	0	0	0	0	0	0	0	0	0	0	0	0	0	0	0	0	0	0	0	0	0	0	0	0	0	
% Pedestrians	0.0%	0.0%	0.0%	0.0%	0.0%	0.0%	0.0%	0.0%	0.0%	0.0%	0.0%	0.0%	0.0%	0.0%	0.0%	0.0%	0.0%	0.0%	0.0%	0.0%	0.0%	0.0%	0.0%	0.0%	0.0%	
Bicycles on Crosswalk	0	0	0	0	0	0	0	0	0	0	0	0	0	0	0	0	0	0	0	0	0	0	0	0	0	
% Bicycles on Crosswalk	0.0%	0.0%	0.0%	0.0%	0.0%	0.0%	0.0%	0.0%	0.0%	0.0%	0.0%	0.0%	0.0%	0.0%	0.0%	0.0%	0.0%	0.0%	0.0%	0.0%	0.0%	0.0%	0.0%	0.0%	0.0%	

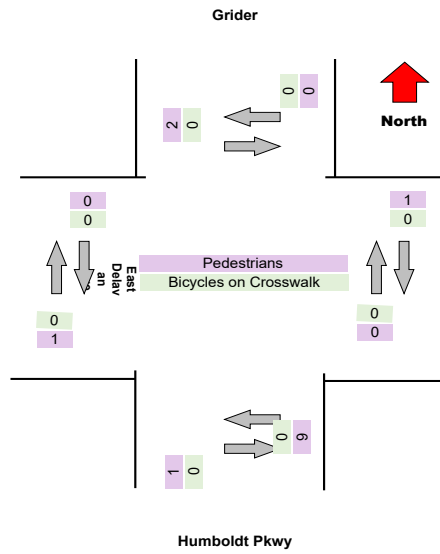
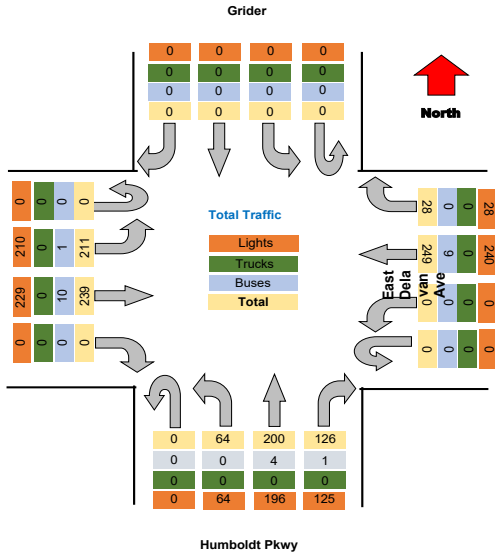

Project : VBH Malta NY
Site : Site 4
Location : 42.948550, -73.790036

TSTData.com

Survey Date : 2021-04-28, Wednesday

Project	Labella
Project Code	Labella
Site Name	27
Legs and Movements	All Processed Legs & Move
Bin Size	15 minutes
Survey Date	2021-10-28, Thursday
Location	27
Latitude and Longitude	42.921924, -78.842814

	Start	End	PHF
Forced Peak AM	2021/10/28 07:30:00	2021/10/28 08:30:00	0.87
Forced Peak PM	2021/10/28 16:30:00	2021/10/28 17:30:00	0.91
AM Peak	2021/10/28 07:30:00	2021/10/28 08:30:00	0.87
PM Peak	2021/10/28 16:30:00	2021/10/28 17:30:00	0.91

Turning Movement Data

Leg Direction	Grider												East Delavan Ave												Humboldt Pkwy												East Delavan Ave												Total
	Southbound						Westbound						Northbound						Eastbound																														
	Right	Thru	Left	U-Turn	App Total	Peds CV	Peds CCV	Right	Thru	Left	U-Turn	App Total	Peds CV	Peds CCV	Right	Thru	Left	U-Turn	App Total	Peds CV	Peds CCV	Right	Thru	Left	U-Turn	App Total	Peds CV	Peds CCV																					
Start Time																																																	
6:30:00 AM	0	0	0	0	0	0	2	21	0	0	23	0	0	6	35	1	0	42	0	0	0	13	45	0	58	0	0	0	0	0	0	0	0																
6:45:00 AM	0	0	0	0	0	0	2	21	0	0	23	0	0	9	32	5	0	46	1	0	0	22	40	0	62	0	0	0	0	0	0	0	0																
Hourly Total	0	0	0	0	0	0	4	42	0	0	46	0	0	15	67	6	0	88	1	0	0	35	85	0	120	0	0	0	0	0	0	0	0																
7:00:00 AM	0	0	0	0	0	0	4	25	0	0	29	0	0	9	35	9	0	53	0	0	0	20	59	0	79	0	0	0	0	0	0	0	0																
7:15:00 AM	0	0	0	0	0	1	4	28	0	0	30	0	0	9	28	6	0	43	0	1	0	27	52	0	79	0	0	0	0	0	0	0	0																
7:30:00 AM	0	0	0	0	0	0	3	44	0	0	47	1	0	21	29	9	0	60	0	3	0	32	69	0	101	0	0	0	0	0	0	0	0																
7:45:00 AM	0	0	0	0	0	1	3	68	0	0	71	0	0	30	44	8	0	82	1	1	0	46	66	0	112	0	0	0	0	0	0	0	0																
Hourly Total	0	0	0	0	0	2	14	163	0	0	177	1	0	69	136	32	0	238	1	5	0	125	246	0	371	0	0	0	0	0	0	0	0																
8:00:00 AM	0	0	0	0	0	1	4	60	0	0	65	0	0	33	33	16	0	82	0	2	0	47	47	0	94	0	0	0	0	0	0	0	0																
8:15:00 AM	0	0	0	0	0	2	2	47	0	0	51	0	0	14	35	12	0	61	0	1	0	36	64	0	100	0	0	0	0	0	0	0	0																
Hourly Total	0	0	0	0	0	3	6	107	0	0	116	0	0	47	68	28	0	143	0	3	0	83	111	0	194	0	0	0	0	0	0	0	0																
4:00:00 PM	0	0	0	0	0	1	15	76	0	0	91	0	0	30	46	16	0	92	4	1	0	52	54	0	106	0	0	0	0	0	0	0	0																
4:15:00 PM	0	0	0	0	0	0	4	66	0	0	70	0	0	40	45	10	0	95	4	1	0	53	47	0	100	0	0	0	0	0	0	0	0																
4:30:00 PM	0	0	0	0	0	0	9	69	0	0	78	0	0	40	37	14	0	91	3	2	0	65	60	0	145	0	0	0	0	0	0	0	0																
4:45:00 PM	0	0	0	0	0	1	4	80	0	0	84	0	0	33	44	12	0	89	1	0	0	51	55	0	106	0	0	0	0	0	0	0	0																
Hourly Total	0	0	0	0	0	2	32	291	0	0	323	0	0	143	172	52	0	367	12	4	0	241	216	0	457	0	0	0	0	0	0	0	0																
5:00:00 PM	0	0	0	0	0	0	6	58	0	0	64	0	0	28	59	16	0	105	1	1	0	41	56	0	97	0	0	0	0	0	0	0	0																
5:15:00 PM	0	0	0	0	0	0	4	60	0	0	64	0	0	42	41	15	0	98	0	0	0	62	61	0	123	2	2	0	0	0	0	0	0																
5:30:00 PM	0	0	0	0	0	0	5	43	0	0	48	0	0	26	58	16	0	100	1	0	0	46	59	0	105	0	0	0	0	0	0	0	0																
5:45:00 PM	0	0	0	0	0	0	3	59	0	0	62	0	0	23	52	15	0	90	0	0	0	36	58	0	94	0	0	0	0	0	0	0	0																
Hourly Total	0	0	0	0	0	0	18	220	0	0	238	0	0	119	210	64	0	393	2	1	0	185	234	0	419	2	2	0	0	0	0	0	0																
Grand Total	0	0	0	0	0	4	74	823	0	0	900	1	0	393	653	182	0	1229	16	13	0	669	892	0	1561	2	2	0	0	0	0	0	0																
% Approach	0.0%	0.0%	0.0%	0.0%	0.0%	0.0%	8.2%	91.4%	0.0%	0.0%	0.0%	0.0%	0.0%	32.0%	53.1%	14.8%	0.0%	0.0%	0.0%	0.0%	0.0%	42.9%	57.1%	0.0%	0.0%	0.0%	0.0%	0.0%	0.0%	0.0%	0.0%	0.0%	0.0%																
% Total	0.0%	0.0%	0.0%	0.0%	0.0%	0.0%	2.0%	22.3%	0.0%	0.0%	24.4%	0.0%	0.0%	10.7%	17.7%	4.9%	0.0%	33.3%	0.0%	0.0%	0.0%	18.1%	24.2%	0.0%	42.3%	0.0%	0.0%	0.0%	0.0%	0.0%	0.0%	0.0%	0.0%																
Lights	0	0	0	0	0	0	73	782	0	0	855	0	0	376	646	167	0	1189	0	0	0	633	868	0	1501	0	0	0	0	0	0	0	0																
% Lights	0.0%	0.0%	0.0%	0.0%	0.0%	0.0%	98.6%	95.0%	0.0%	0.0%	95.0%	0.0%	0.0%	95.7%	98.9%	91.8%	0.0%	96.7%	0.0%	0.0%	0.0%	94.6%	97.3%	0.0%	96.2%	0.0%	0.0%	0.0%	0.0%	0.0%	0.0%	0.0%	0.0%																
Trucks	0	0	0	0	0	0	0	1	0	0	1	0	0	0	0	0	0	0	0	0	0	0	1	0	1	0	0	0	0	0	0	0	0																
% Trucks	0.0%	0.0%	0.0%	0.0%	0.0%	0.0%	0.0%	0.1%	0.0%	0.0%	0.1%	0.0%	0.0%	0.0%	0.0%	0.0%	0.0%	0.0%	0.0%	0.0%	0.0%	0.0%	0.1%	0.0%	0.1%	0.0%	0.0%	0.0%	0.0%	0.0%	0.0%	0.0%	0.0%																
Buses	0	0	0	0	0	0	1	38	0	0	39	0	0	17	7	15	0	39	0	0	0	36	23	0	59	0	0	0	0	0	0	0	0																
% Buses	0.0%	0.0%	0.0%	0.0%	0.0%	0.0%	0.0%	4.6%	0.0%	0.0%	0.0%	0.0%	0.0%	4.3%	1.1%	8.2%	0.0%	0.0%	0.0%	0.0%	0.0%	5.4%	2.6%	0.0%	0.0%	0.0%	0.0%	0.0%	0.0%	0.0%	0.0%	0.0%	0.0%																
Pedestrians	0	0	0	0	0	4	0	0	0	0	0	1	0	0	0	0	0	0	15	12	0	0	0	0	0	2	2	0	0	0	0	0	0																
% Pedestrians	0.0%	0.0%	0.0%	0.0%	0.0%	100.0%	0.0%	0.0%	0.0%	0.0%	0.0%	100.0%	0.0%	0.0%	0.0%	0.0%	0.0%	0.0%	93.8%	92.3%	0.0%	0.0%	0.0%	0.0%	0.0%	100.0%	100.0%	0.0%	0.0%	0.0%	0.0%	0.0%	0.0%																
Bicycles on Crosswalk	0	0	0	0	0	2	0	0	0	0	0	0	0	0	0	0	0	0	1	1	0	0	0	0	0	0	0	0	0	0	0	0	0																
% Bicycles on Crosswalk	0.0%	0.0%	0.0%	0.0%	0.0%	50.0%	0.0%	0.0%	0.0%	0.0%	0.0%	0.0%	0.0%	0.0%	0.0%	0.0%	0.0%	0.0%	6.3%	7.7%	0.0%	0.0%	0.0%	0.0%	0.0%	0.0%	0.0%	0.0%	0.0%	0.0%	0.0%	0.0%	0.0%																

Turning Movement Data Plot

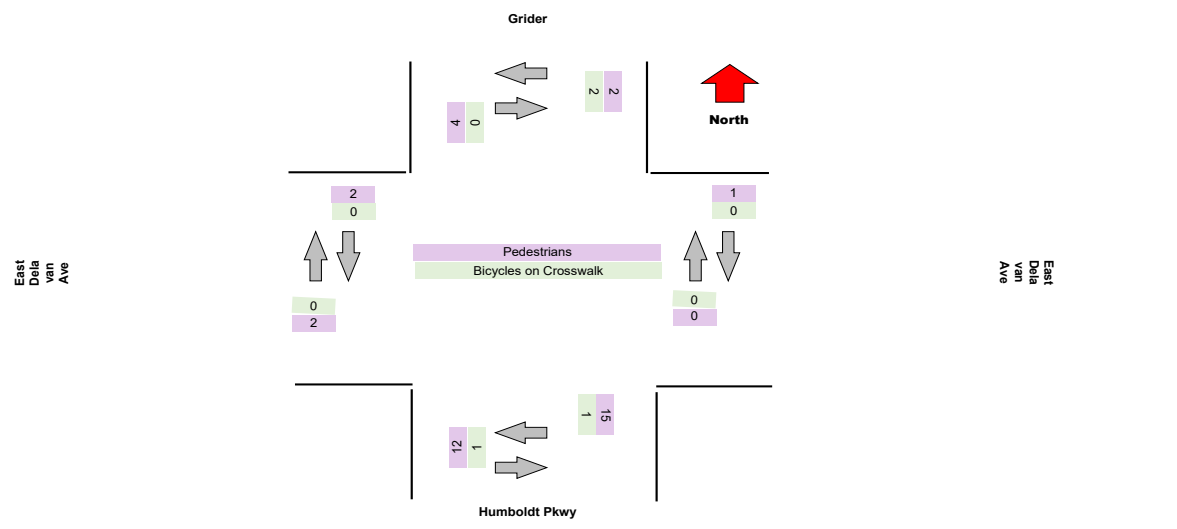
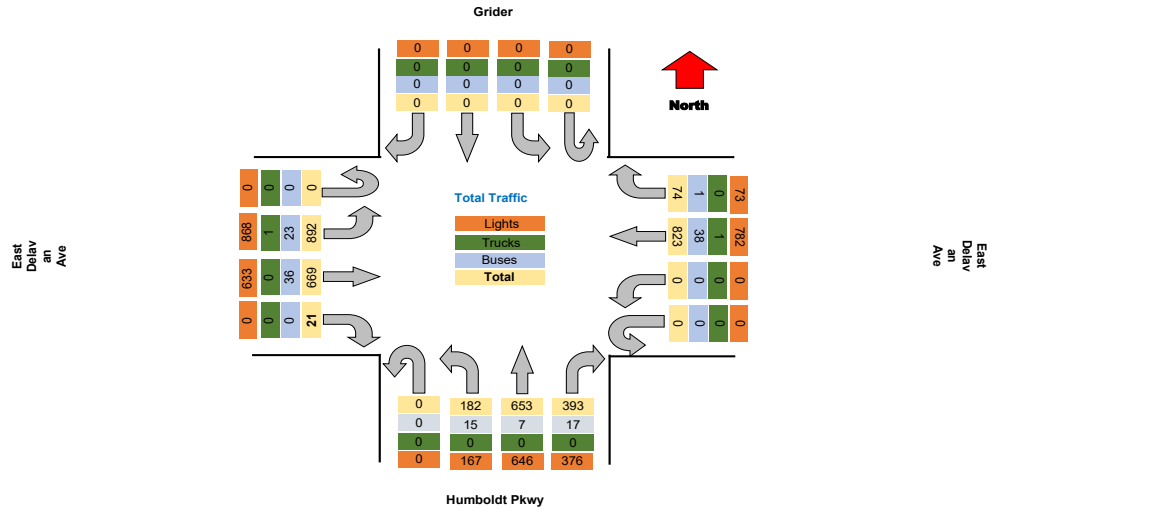

Turning Movement Peak Hour Data (AM)

7:30:00 AM

Leg Direction	Grider										East Delavan Ave										Humboldt Pkwy										East Delavan Ave										Total
	Southbound					Westbound					Northbound					Eastbound					Northbound					Eastbound															
	Right	Thru	Left	U-Turn	App Total	Right	Thru	Left	U-Turn	App Total	Right	Thru	Left	U-Turn	App Total	Right	Thru	Left	U-Turn	App Total	Right	Thru	Left	U-Turn	App Total	Right	Thru	Left	U-Turn	App Total											
7:30:00 AM	0	0	0	0	0	3	44	0	0	47	1	0	0	0	1	21	29	9	0	60	0	32	69	0	101	0	0	0	0	0	208										
7:45:00 AM	0	0	0	0	0	3	68	0	0	71	0	0	0	0	0	30	44	8	0	82	1	1	1	0	46	66	0	0	0	112	266										
8:00:00 AM	0	0	0	0	0	4	60	0	0	65	0	0	0	0	0	33	33	16	0	82	0	2	2	0	47	47	0	0	0	94	241										
8:15:00 AM	0	0	0	0	0	2	47	0	0	51	0	0	0	0	0	14	36	12	0	61	0	1	1	0	36	64	0	0	0	100	212										
Grand Total	0	0	0	0	0	12	219	0	0	234	1	0	0	0	1	88	141	45	0	235	1	7	7	0	161	246	0	0	0	407	926										
% Approach	#DIV/0!	#DIV/0!	#DIV/0!	#DIV/0!	0.0%	14.2%	85.8%	0.0%	0.0%	0.0%	45.1%	41.7%	13.2%	0.0%	0.0%	0.0%	66.2%	33.8%	0.0%	0.0%	0.0%	66.2%	33.8%	0.0%	0.0%	0.0%	66.2%	33.8%	0.0%	0.0%											
% Total	0.0%	0.0%	0.0%	0.0%	0.0%	1.3%	23.7%	0.0%	0.0%	25.3%	0.0%	0.0%	0.0%	0.0%	0.0%	10.6%	15.2%	4.9%	0.0%	30.8%	0.0%	0.0%	0.0%	0.0%	44.0%	0.0%	0.0%	0.0%	0.0%	44.0%											
PHF	0.000	0.000	0.000	0.000	0.000	0.750	0.805	0.000	0.000	0.824	0.000	0.000	0.000	0.000	0.000	0.742	0.801	0.703	0.000	0.869	0.000	0.000	0.000	0.000	0.908	0.000	0.000	0.000	0.000	0.908											
Lights	0	0	0	0	0	12	203	0	0	215	0	0	0	0	0	95	138	42	0	275	0	0	0	0	393	0	0	0	0	393											
% Lights	0.0%	0.0%	0.0%	0.0%	0.0%	100.0%	92.7%	0.0%	0.0%	91.9%	0.0%	0.0%	0.0%	0.0%	0.0%	96.9%	97.0%	93.3%	0.0%	96.6%	0.0%	0.0%	0.0%	0.0%	96.6%	0.0%	0.0%	0.0%	0.0%	96.4%											
Trucks	0	0	0	0	0	0	1	0	0	1	0	0	0	0	0	0	0	0	0	0	0	0	1	0	1	0	0	0	0	1											
% Trucks	0.0%	0.0%	0.0%	0.0%	0.0%	0.0%	0.5%	0.0%	0.0%	0.4%	0.0%	0.0%	0.0%	0.0%	0.0%	0.0%	0.0%	0.0%	0.0%	0.0%	0.0%	0.0%	0.4%	0.0%	0.2%	0.0%	0.0%	0.0%	0.0%	0.2%											
Buses	0	0	0	0	0	0	15	0	0	15	0	0	0	0	0	3	3	3	0	9	0	0	0	0	13	0	0	0	0	13											
% Buses	0.0%	0.0%	0.0%	0.0%	0.0%	0.0%	6.8%	0.0%	0.0%	6.4%	0.0%	0.0%	0.0%	0.0%	0.0%	3.1%	2.1%	6.7%	0.0%	3.8%	0.0%	0.0%	0.0%	0.0%	8.1%	0.0%	0.0%	0.0%	0.0%	8.1%											
Pedestrians	0	0	0	0	1	0	0	0	0	0	1	0	0	0	1	0	0	0	0	0	1	6	0	0	7	0	0	0	0	7											
% Pedestrians	0.0%	0.0%	0.0%	0.0%	100.0%	0.0%	0.0%	0.0%	0.0%	0.0%	100.0%	0.0%	0.0%	0.0%	100.0%	0.0%	0.0%	0.0%	0.0%	0.0%	100.0%	85.7%	0.0%	0.0%	100.0%	0.0%	0.0%	0.0%	0.0%	100.0%											
Bicycles on Crosswalk	0	0	0	0	2	0	0	0	0	0	0	0	0	0	0	0	0	0	0	0	0	1	0	0	1	0	0	0	0	1											
% Bicycles on Crosswalk	0.0%	0.0%	0.0%	0.0%	0.0%	0.0%	0.0%	0.0%	0.0%	0.0%	0.0%	0.0%	0.0%	0.0%	0.0%	0.0%	0.0%	0.0%	0.0%	0.0%	0.0%	14.3%	0.0%	0.0%	14.3%	0.0%	0.0%	0.0%	0.0%	14.3%											

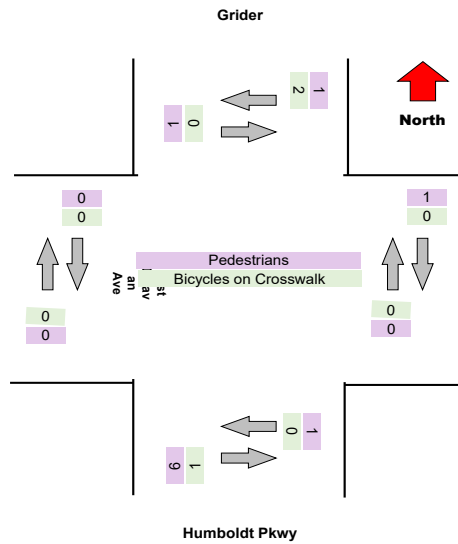
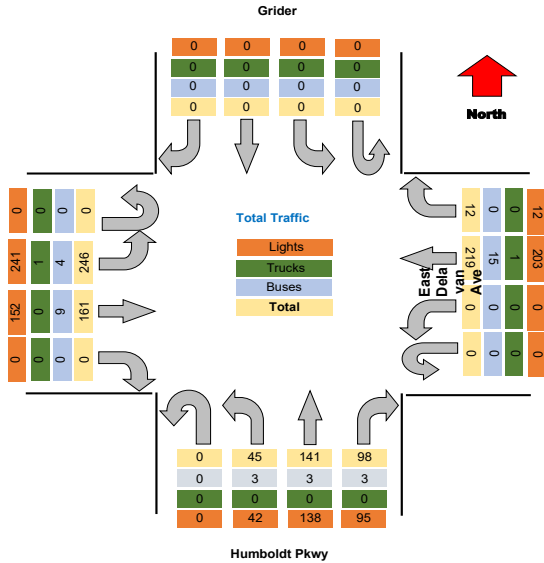

Turning Movement Peak Hour Data (PM)

4:30:00 PM

Leg Direction	Grider										East Delavan Ave										Humboldt Pkwy										East Delavan Ave										Total
	Southbound					Northbound					Westbound					Eastbound					Northbound					Eastbound															
	Right	Thru	Left	U-Turn	App Total	Peds CW	Peds CCW	Right	Thru	Left	U-Turn	App Total	Peds CW	Peds CCW	Right	Thru	Left	U-Turn	App Total	Peds CW	Peds CCW	Right	Thru	Left	U-Turn	App Total	Peds CW	Peds CCW													
4:30:00 PM	0	0	0	0	0	0	0	0	0	0	9	69	0	0	78	0	0	0	0	0	40	37	14	0	91	3	2	0	0	5	0	85	60	0	145	0	0	0	0	0	314
4:45:00 PM	0	0	0	0	0	0	1	0	0	1	4	80	0	0	84	0	0	0	0	0	33	44	12	0	89	1	0	0	0	1	0	51	55	0	106	0	0	0	0	0	279
5:00:00 PM	0	0	0	0	0	0	0	0	0	0	6	58	0	0	64	0	0	0	0	0	28	59	18	0	105	1	1	0	0	2	0	41	56	0	97	0	0	0	0	0	266
5:15:00 PM	0	0	0	0	0	0	0	0	0	0	4	60	0	0	64	0	0	0	0	0	42	41	15	0	98	0	0	0	0	0	0	62	51	0	123	2	2	0	0	4	285
Grand Total	0	0	0	0	0	0	1	0	0	1	23	257	0	0	280	0	0	0	0	0	143	181	59	0	383	5	2	0	0	7	0	239	222	0	471	2	2	0	0	4	1144
% Approach	#DIV/0!	#DIV/0!	#DIV/0!	#DIV/0!	0.0%	0.0%	0.0%	0.0%	0.0%	0.0%	14.2%	85.8%	0.0%	0.0%	0.0%	0.0%	0.0%	0.0%	0.0%	0.0%	45.1%	41.7%	13.2%	0.0%	0.0%	0.0%	0.0%	0.0%	0.0%	0.0%	0.0%	66.2%	33.8%	0.0%	0.0%	0.0%	0.0%	0.0%	0.0%	0.0%	
% Total	0.0%	0.0%	0.0%	0.0%	0.0%	0.0%	0.0%	0.0%	0.0%	0.0%	2.0%	23.3%	0.0%	0.0%	25.3%	0.0%	0.0%	0.0%	0.0%	0.0%	12.5%	15.8%	5.2%	0.0%	33.5%	0.0%	0.0%	0.0%	0.0%	0.0%	0.0%	20.9%	20.3%	0.0%	41.2%	0.0%	0.0%	0.0%	0.0%	0.0%	
PHF	0.000	0.000	0.000	0.000	0.000	0.000	0.000	0.000	0.000	0.000	0.639	0.834	0.000	0.000	0.863	0.000	0.000	0.000	0.000	0.000	0.851	0.767	0.819	0.000	0.812	0.000	0.000	0.000	0.000	0.000	0.000	0.703	0.951	0.000	0.812	0.000	0.000	0.000	0.000	0.000	
Lights	0	0	0	0	0	0	0	0	0	0	23	258	0	0	281	0	0	0	0	0	143	180	59	0	382	0	0	0	0	0	0	231	228	0	459	0	0	0	0	0	1122
% Lights	0.0%	0.0%	0.0%	0.0%	0.0%	0.0%	0.0%	0.0%	0.0%	0.0%	100.0%	96.6%	0.0%	0.0%	96.9%	0.0%	0.0%	0.0%	0.0%	0.0%	100.0%	99.4%	100.0%	0.0%	99.7%	0.0%	0.0%	0.0%	0.0%	0.0%	0.0%	96.7%	98.3%	0.0%	97.5%	0.0%	0.0%	0.0%	0.0%	0.0%	
Trucks	0	0	0	0	0	0	0	0	0	0	0	0	0	0	0	0	0	0	0	0	0	0	0	0	0	0	0	0	0	0	0	0	0	0	0	0	0	0	0	0	0
% Trucks	0.0%	0.0%	0.0%	0.0%	0.0%	0.0%	0.0%	0.0%	0.0%	0.0%	0.0%	0.0%	0.0%	0.0%	0.0%	0.0%	0.0%	0.0%	0.0%	0.0%	0.0%	0.0%	0.0%	0.0%	0.0%	0.0%	0.0%	0.0%	0.0%	0.0%	0.0%	0.0%	0.0%	0.0%	0.0%	0.0%	0.0%	0.0%	0.0%	0.0%	
Buses	0	0	0	0	0	0	0	0	0	0	0	8	0	0	8	0	0	0	0	0	0	1	0	0	1	0	0	0	0	0	0	8	4	0	12	0	0	0	0	0	21
% Buses	0.0%	0.0%	0.0%	0.0%	0.0%	0.0%	0.0%	0.0%	0.0%	0.0%	0.0%	3.0%	0.0%	0.0%	0.0%	0.0%	0.0%	0.0%	0.0%	0.0%	0.0%	0.6%	0.0%	0.0%	0.0%	0.0%	0.0%	0.0%	0.0%	0.0%	0.0%	3.3%	1.7%	0.0%	0.0%	0.0%	0.0%	0.0%	0.0%	0.0%	
Pedestrians	0	0	0	0	0	0	1	0	0	1	0	0	0	0	0	0	0	0	0	0	0	0	0	0	5	3	0	0	0	3	0	0	0	0	0	2	2	0	0	4	0
% Pedestrians	0.0%	0.0%	0.0%	0.0%	0.0%	0.0%	100.0%	0.0%	0.0%	0.0%	0.0%	0.0%	0.0%	0.0%	0.0%	0.0%	0.0%	0.0%	0.0%	0.0%	0.0%	0.0%	0.0%	0.0%	0.0%	100.0%	100.0%	0.0%	0.0%	0.0%	0.0%	100.0%	100.0%	0.0%	0.0%	100.0%	100.0%	0.0%	0.0%	0.0%	
Bicycles on Crosswalk	0	0	0	0	0	0	0	0	0	0	0	0	0	0	0	0	0	0	0	0	0	0	0	0	0	0	0	0	0	0	0	0	0	0	0	0	0	0	0	0	0
% Bicycles on Crosswalk	0.0%	0.0%	0.0%	0.0%	0.0%	0.0%	0.0%	0.0%	0.0%	0.0%	0.0%	0.0%	0.0%	0.0%	0.0%	0.0%	0.0%	0.0%	0.0%	0.0%	0.0%	0.0%	0.0%	0.0%	0.0%	0.0%	0.0%	0.0%	0.0%	0.0%	0.0%	0.0%	0.0%	0.0%	0.0%	0.0%	0.0%	0.0%	0.0%	0.0%	

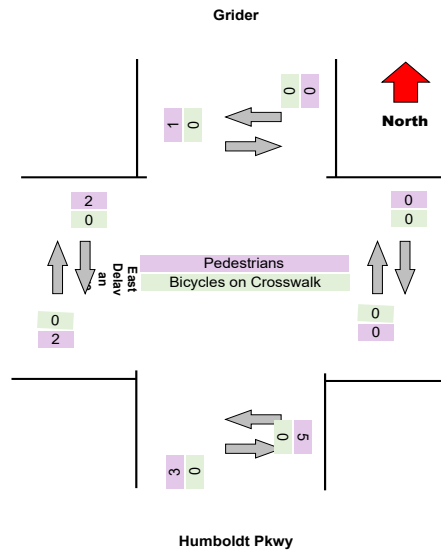
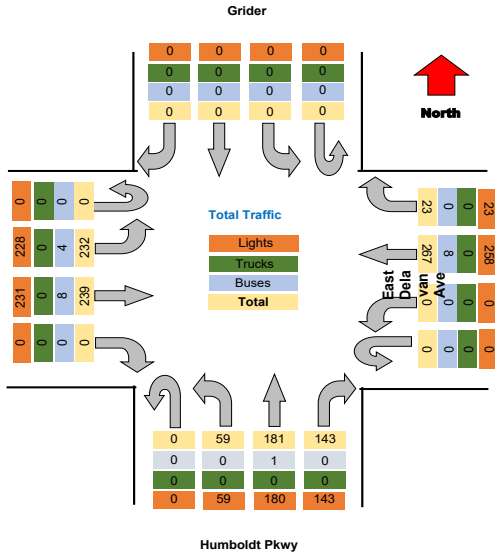

Project : VBH Malta NY
 Site : Site 4
 Location : 42.948550, -73.790036
 Survey Date : 2021-04-28, Wednesday

Turning Movement Data Plot

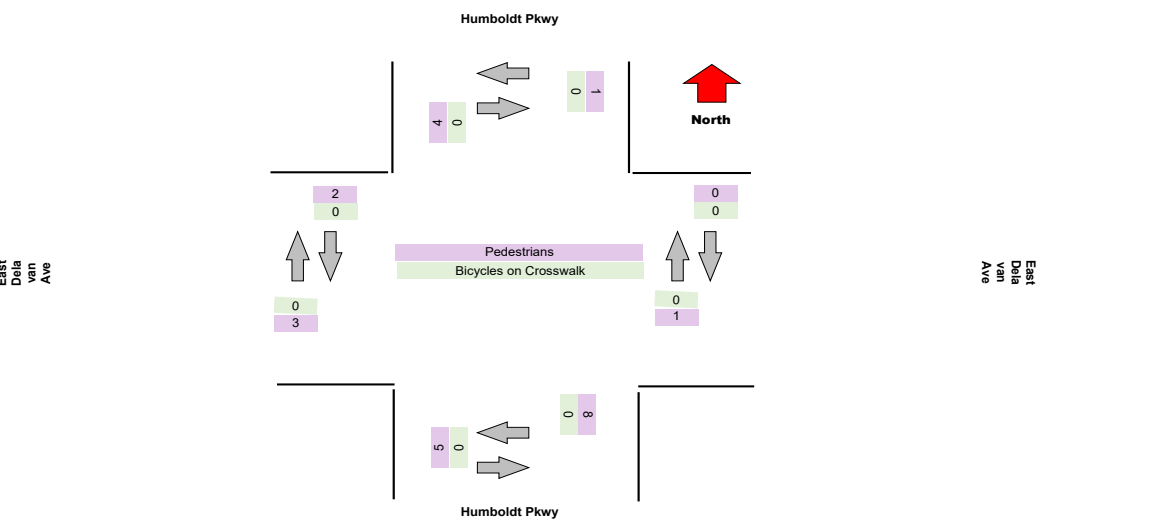
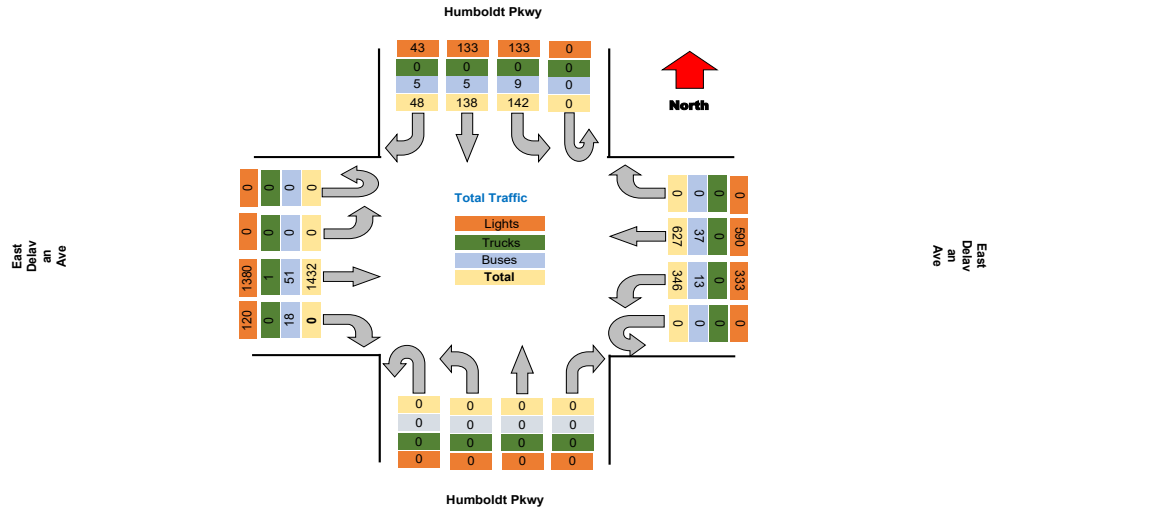

Turning Movement Peak Hour Data (AM)

7:30:00 AM

Leg Direction	Humboldt Pkwy					East Delavan Ave					Humboldt Pkwy					East Delavan Ave					Total									
	Southbound		Westbound			Northbound		Eastbound			Southbound		Westbound			Northbound		Eastbound												
Start Time	Right	Thru	Left	U-Turn	App Total	Peds CW	Peds CCW	Right	Thru	Left	U-Turn	App Total	Peds CW	Peds CCW	Right	Thru	Left	U-Turn	App Total	Peds CW	Peds CCW									
7:30:00 AM	1	6	12	0	19	0	0	0	35	18	0	53	0	0	0	0	0	0	0	0	0	98	1	0	170					
7:45:00 AM	1	4	9	0	14	0	0	0	36	17	0	53	0	0	0	0	0	0	0	0	0	6	108	0	0	114	1	0	181	
8:00:00 AM	1	5	4	0	10	0	0	0	48	26	0	76	0	0	0	0	0	0	0	1	0	3	83	0	0	86	0	0	172	
8:15:00 AM	3	7	8	0	18	0	0	0	44	25	0	69	0	0	0	0	0	0	0	0	0	9	114	0	0	123	0	0	210	
Grand Total	6	22	33	0	61	0	0	0	153	88	0	251	0	0	0	0	0	0	0	1	0	25	396	0	0	421	2	0	733	
% Approach	9.8%	36.1%	54.1%	0.0%	0.0%	0.0%	0.0%	14.2%	85.8%	0.0%	0.0%	0.0%	0.0%	0.0%	45.1%	41.7%	13.2%	0.0%	0.0%	0.0%	0.0%	0.0%	66.2%	33.8%	0.0%	0.0%	0.0%	0.0%	0.0%	
% Total	0.8%	3.0%	4.5%	0.0%	8.3%	0.0%	0.0%	0.0%	22.2%	12.0%	0.0%	34.2%	0.0%	0.0%	0.0%	0.0%	0.0%	0.0%	0.0%	0.0%	0.0%	3.4%	54.0%	0.0%	0.0%	67.4%	0.0%	0.0%	0.0%	
PHF	0.500	0.786	0.688	0.000	0.803	0.000	0.000	0.000	0.849	0.786	0.000	0.826	0.000	0.000	0.000	0.000	0.000	0.000	0.000	0.000	0.000	0.694	0.868	0.000	0.000	0.856	0.000	0.000	0.873	
Lights	5	21	31	0	57	0	0	0	150	87	0	237	0	0	0	0	0	0	0	0	0	21	386	0	0	407	0	0	701	
% Lights	83.3%	95.5%	93.9%	0.0%	93.4%	0.0%	0.0%	0.0%	92.0%	98.9%	0.0%	94.4%	0.0%	0.0%	0.0%	0.0%	0.0%	0.0%	0.0%	0.0%	0.0%	84.0%	97.5%	0.0%	0.0%	96.7%	0.0%	0.0%	95.6%	
Trucks	0	0	0	0	0	0	0	0	0	0	0	0	0	0	0	0	0	0	0	0	0	0	1	0	0	1	0	0	1	
% Trucks	0.0%	0.0%	0.0%	0.0%	0.0%	0.0%	0.0%	0.0%	0.0%	0.0%	0.0%	0.0%	0.0%	0.0%	0.0%	0.0%	0.0%	0.0%	0.0%	0.0%	0.0%	0.0%	0.3%	0.0%	0.0%	0.2%	0.0%	0.0%	0.1%	
Buses	1	1	2	0	4	0	0	0	13	1	0	14	0	0	0	0	0	0	0	0	0	4	9	0	0	13	0	0	31	
% Buses	16.7%	4.5%	6.1%	0.0%	6.6%	0.0%	0.0%	0.0%	8.0%	1.1%	0.0%	5.0%	0.0%	0.0%	0.0%	0.0%	0.0%	0.0%	0.0%	0.0%	0.0%	16.0%	2.3%	0.0%	0.0%	3.0%	0.0%	0.0%	4.2%	
Pedestrians	0	0	0	0	0	0	0	0	0	0	0	0	0	0	0	0	0	0	0	0	0	0	0	0	0	0	2	0	0	
% Pedestrians	0.0%	0.0%	0.0%	0.0%	0.0%	0.0%	0.0%	0.0%	0.0%	0.0%	0.0%	0.0%	0.0%	0.0%	0.0%	0.0%	0.0%	0.0%	0.0%	0.0%	0.0%	0.0%	0.0%	0.0%	0.0%	0.0%	0.5%	100.0%	0.0%	0.0%
Bicycles on Crosswalk	0	0	0	0	0	0	0	0	0	0	0	0	0	0	0	0	0	0	0	0	0	0	0	0	0	0	0	0	0	
% Bicycles on Crosswalk	0.0%	0.0%	0.0%	0.0%	0.0%	0.0%	0.0%	0.0%	0.0%	0.0%	0.0%	0.0%	0.0%	0.0%	0.0%	0.0%	0.0%	0.0%	0.0%	0.0%	0.0%	0.0%	0.0%	0.0%	0.0%	0.0%	0.0%	0.0%	0.0%	

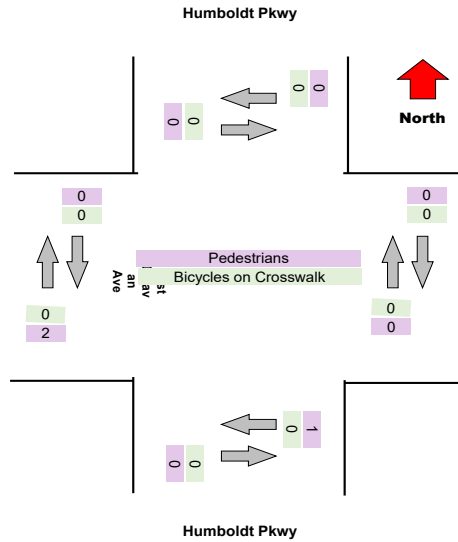
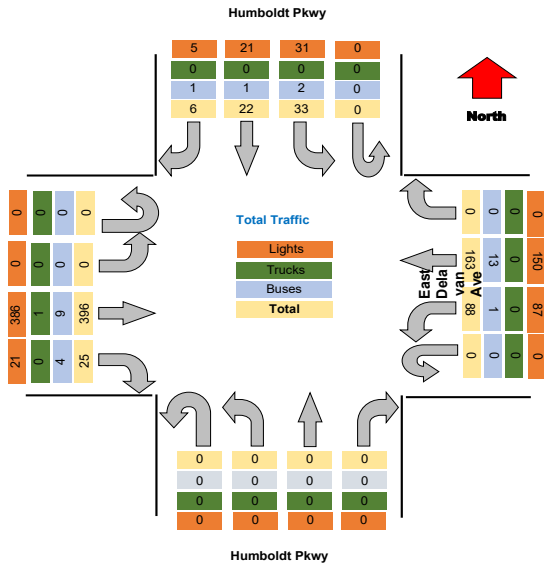

Turning Movement Peak Hour Data (PM)

4:30:00 PM

Leg Direction	Humboldt Pkwy										East Delavan Ave										Total	
	Southbound					Westbound					Northbound					Eastbound						
	Right	Thru	Left	U-Turn	App Total	Right	Thru	Left	U-Turn	App Total	Right	Thru	Left	U-Turn	App Total	Right	Thru	Left	U-Turn	App Total		
4:30:00 PM	3	11	16	0	30	0	47	29	0	76	0	0	0	0	0	18	116	0	0	134	240	
4:45:00 PM	6	15	13	0	34	0	60	23	0	83	0	0	0	0	0	11	90	0	0	101	218	
5:00:00 PM	2	17	11	0	30	0	45	25	0	70	0	0	0	0	0	10	82	0	0	92	192	
5:15:00 PM	8	14	18	0	41	0	44	21	0	65	0	0	0	0	0	9	103	0	0	112	218	
Grand Total	20	57	58	0	135	0	156	98	0	254	0	0	0	0	0	48	391	0	0	439	868	
% Approach	14.8%	42.2%	43.0%	0.0%	0.0%	14.2%	85.8%	0.0%	0.0%	0.0%	45.1%	41.7%	13.2%	0.0%	0.0%	0.0%	66.2%	33.8%	0.0%	0.0%	0.0%	0.0%
% Total	2.3%	6.6%	6.7%	0.0%	15.6%	0.0%	22.6%	11.3%	0.0%	33.9%	0.0%	0.0%	0.0%	0.0%	0.0%	5.5%	45.0%	0.0%	0.0%	50.6%	0.0%	0.0%
PHF	0.556	0.838	0.806	0.000	0.823	0.000	0.817	0.845	0.000	0.886	0.000	0.000	0.000	0.000	0.000	0.667	0.843	0.000	0.000	0.819	0.000	0.000
Lights	18	55	55	0	128	0	187	98	0	285	0	0	0	0	0	41	380	0	0	421	834	
% Lights	80.0%	96.5%	94.8%	0.0%	94.8%	0.0%	95.4%	100.0%	0.0%	96.9%	0.0%	0.0%	0.0%	0.0%	0.0%	85.4%	97.2%	0.0%	0.0%	95.9%	96.1%	
Trucks	0	0	0	0	0	0	0	0	0	0	0	0	0	0	0	0	0	0	0	0	0	0
% Trucks	0.0%	0.0%	0.0%	0.0%	0.0%	0.0%	0.0%	0.0%	0.0%	0.0%	0.0%	0.0%	0.0%	0.0%	0.0%	0.0%	0.0%	0.0%	0.0%	0.0%	0.0%	0.0%
Buses	2	2	3	0	7	0	9	0	0	9	0	0	0	0	0	7	11	0	0	18	34	
% Buses	10.0%	3.5%	5.2%	0.0%	0.0%	0.0%	4.6%	0.0%	0.0%	0.0%	0.0%	0.0%	0.0%	0.0%	0.0%	14.6%	2.8%	0.0%	0.0%	0.0%	3.9%	0.0%
Pedestrians	0	0	0	0	0	0	0	0	0	0	0	0	0	0	0	0	0	0	0	0	1	0
% Pedestrians	0.0%	0.0%	0.0%	0.0%	0.0%	0.0%	0.0%	0.0%	0.0%	0.0%	0.0%	0.0%	0.0%	0.0%	0.0%	0.0%	0.0%	0.0%	0.0%	0.0%	100.0%	100.0%
Bicycles on Crosswalk	0	0	0	0	0	0	0	0	0	0	0	0	0	0	0	0	0	0	0	0	0	0
% Bicycles on Crosswalk	0.0%	0.0%	0.0%	0.0%	0.0%	0.0%	0.0%	0.0%	0.0%	0.0%	0.0%	0.0%	0.0%	0.0%	0.0%	0.0%	0.0%	0.0%	0.0%	0.0%	0.0%	0.0%

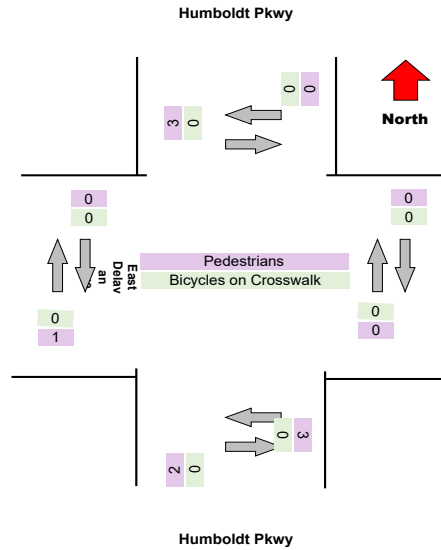
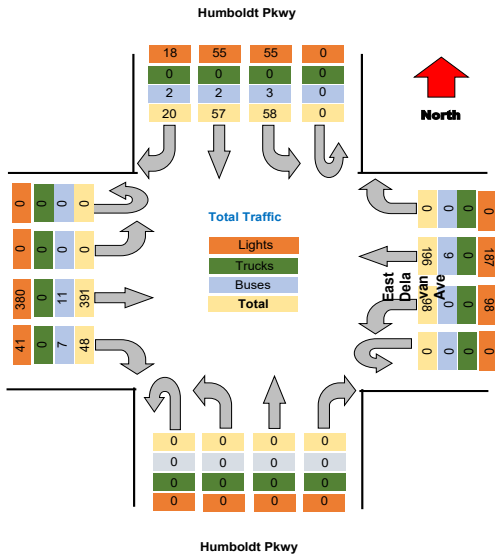

Project : VBH Malta NY
 Site : Site 4
 Location : 42.948550, -73.790036
 Survey Date : 2021-04-28, Wednesday

Turning Movement Data Plot

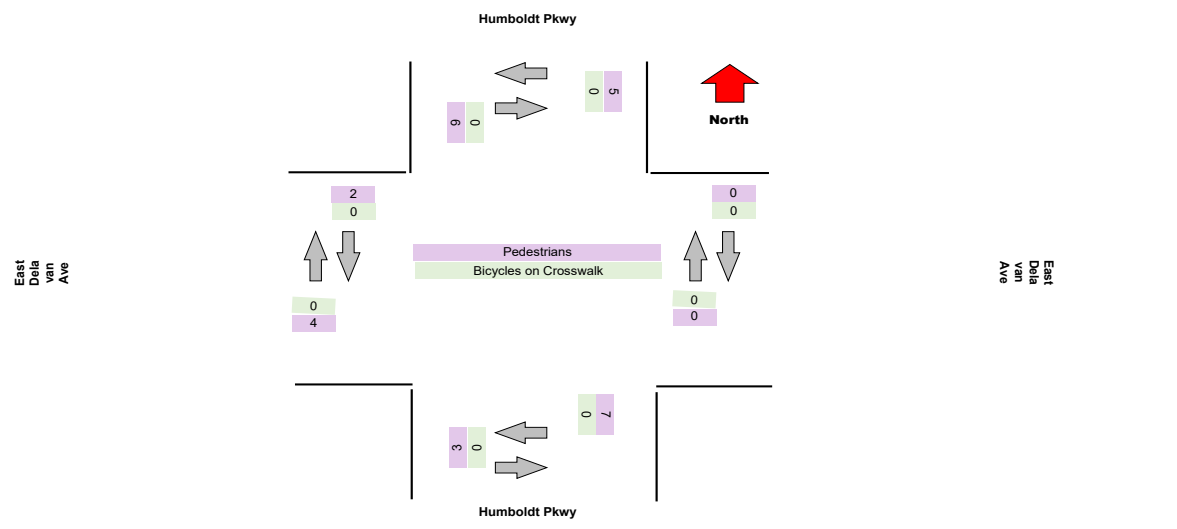
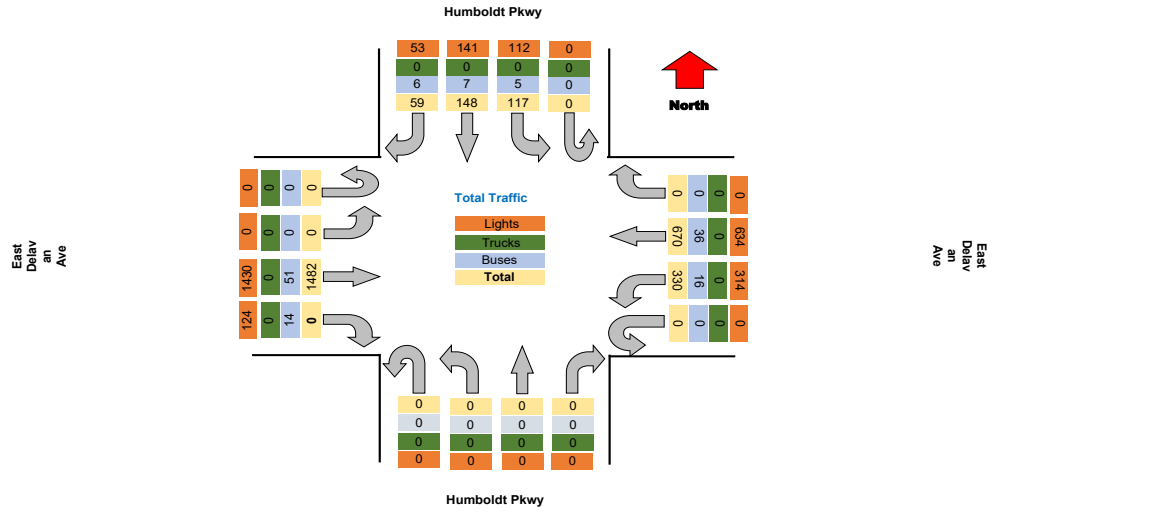

Project : VBH Malta NY
Site : Site 4
Location : 42.948550, -73.790036

TSTData.com

Survey Date : 2021-04-28, Wednesday

Turning Movement Peak Hour Data (AM)

7:30:00 AM

Leg Direction	Humboldt Pkwy						East Delavan Ave						Humboldt Pkwy						East Delavan Ave						Total			
	Southbound			Northbound			Westbound			Eastbound			Northbound			Eastbound												
Start Time	Right	Thru	Left	U-Turn	App Total	Peds CW	Peds CCW	Right	Thru	Left	U-Turn	App Total	Peds CW	Peds CCW	Right	Thru	Left	U-Turn	App Total	Peds CW	Peds CCW	Right	Thru	Left	U-Turn	App Total	Peds CW	Peds CCW
7:30:00 AM	4	3	9	0	16	1	0	0	29	16	0	45	0	0	0	0	0	0	0	0	0	9	96	0	0	105	1	0
7:45:00 AM	1	8	9	0	18	0	0	0	43	25	0	68	0	0	0	0	0	0	0	0	0	5	93	0	0	98	0	0
8:00:00 AM	3	7	4	0	14	1	0	0	45	19	0	64	0	0	0	0	0	0	0	0	0	6	91	0	0	97	0	0
8:15:00 AM	3	9	3	0	15	0	0	0	39	20	0	59	0	0	0	0	0	0	0	0	0	5	100	0	0	105	0	0
Grand Total	11	27	25	0	63	2	0	0	156	80	0	237	0	0	0	0	0	0	0	0	25	380	0	0	405	1	0	
% Approach	17.5%	42.2%	39.7%	0.0%	0.0%	0.0%	0.0%	14.2%	85.8%	0.0%	0.0%	0.0%	0.0%	0.0%	45.1%	41.7%	13.2%	0.0%	0.0%	0.0%	0.0%	66.2%	33.8%	0.0%	0.0%	0.0%	0.0%	0.0%
% Total	1.6%	3.8%	3.5%	0.0%	8.3%	0.0%	0.0%	0.0%	22.1%	11.3%	0.0%	33.6%	0.0%	0.0%	0.0%	0.0%	0.0%	0.0%	0.0%	0.0%	0.0%	3.5%	53.9%	0.0%	0.0%	67.4%	0.0%	0.0%
PHF	0.688	0.750	0.694	0.000	0.875	0.000	0.000	0.000	0.887	0.800	0.000	0.871	0.000	0.000	0.000	0.000	0.000	0.000	0.000	0.000	0.000	0.694	0.950	0.000	0.000	0.964	0.000	0.000
Lights	10	25	25	0	60	0	0	0	142	77	0	219	0	0	0	0	0	0	0	0	0	21	368	0	0	389	0	0
% Lights	80.9%	92.6%	100.0%	0.0%	95.2%	0.0%	0.0%	0.0%	91.0%	96.3%	0.0%	92.4%	0.0%	0.0%	0.0%	0.0%	0.0%	0.0%	0.0%	0.0%	0.0%	84.0%	96.8%	0.0%	0.0%	96.0%	0.0%	0.0%
Trucks	0	0	0	0	0	0	0	0	0	0	0	0	0	0	0	0	0	0	0	0	0	0	0	0	0	0	0	0
% Trucks	0.0%	0.0%	0.0%	0.0%	0.0%	0.0%	0.0%	0.0%	0.0%	0.0%	0.0%	0.0%	0.0%	0.0%	0.0%	0.0%	0.0%	0.0%	0.0%	0.0%	0.0%	0.0%	0.0%	0.0%	0.0%	0.0%	0.0%	0.0%
Buses	1	2	0	0	3	0	0	0	14	3	0	17	0	0	0	0	0	0	0	0	0	4	12	0	0	16	0	0
% Buses	3.1%	7.4%	0.0%	0.0%	0.0%	0.0%	0.0%	0.0%	9.0%	3.8%	0.0%	0.0%	0.0%	0.0%	0.0%	0.0%	0.0%	0.0%	0.0%	0.0%	16.0%	3.2%	0.0%	0.0%	0.0%	0.0%	0.0%	
Pedestrians	0	0	0	0	0	2	1	0	0	0	0	0	0	0	0	0	0	0	0	0	0	0	0	0	0	0	1	0
% Pedestrians	0.0%	0.0%	0.0%	0.0%	0.0%	100.0%	100.0%	0.0%	0.0%	0.0%	0.0%	0.0%	0.0%	0.0%	0.0%	0.0%	0.0%	0.0%	0.0%	0.0%	0.0%	0.0%	0.0%	0.0%	0.0%	0.0%	100.0%	0.0%
Bicycles on Crosswalk	0	0	0	0	0	0	0	0	0	0	0	0	0	0	0	0	0	0	0	0	0	0	0	0	0	0	0	0
% Bicycles on Crosswalk	0.0%	0.0%	0.0%	0.0%	0.0%	0.0%	0.0%	0.0%	0.0%	0.0%	0.0%	0.0%	0.0%	0.0%	0.0%	0.0%	0.0%	0.0%	0.0%	0.0%	0.0%	0.0%	0.0%	0.0%	0.0%	0.0%	0.0%	0.0%

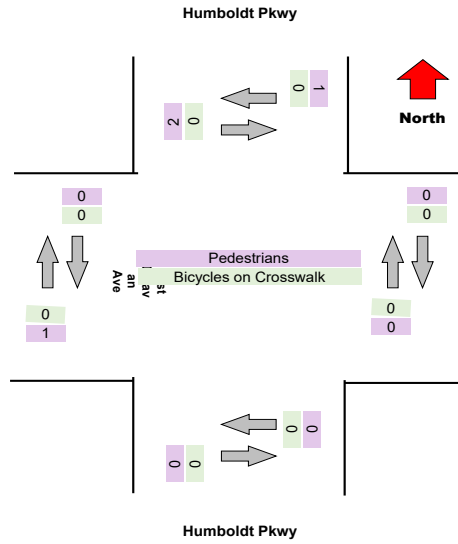
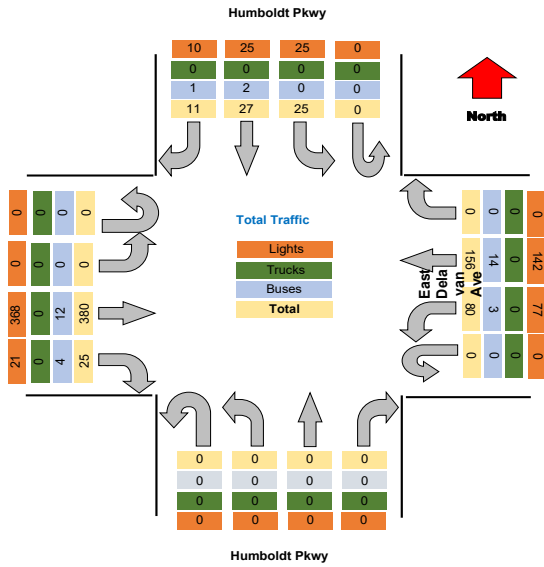

Turning Movement Peak Hour Data (PM)

4:30:00 PM

Leg Direction	Humboldt Pkwy										East Delavan Ave										Total									
	Southbound					Westbound					Northbound					Eastbound														
	Right	Thru	Left	U-Turn	App Total	Peds CW	Peds CCW	Right	Thru	Left	U-Turn	App Total	Peds CW	Peds CCW	Right	Thru	Left	U-Turn	App Total	Peds CW		Peds CCW								
4:30:00 PM	6	17	9	0	32	0	0	0	57	26	0	83	0	0	0	0	0	0	0	4	1	8	112	0	0	120	0	1	235	
4:45:00 PM	4	15	11	0	30	0	0	0	53	25	0	78	0	0	0	0	0	0	0	0	0	8	107	0	0	115	1	0	223	
5:00:00 PM	6	13	10	0	29	1	0	0	53	19	0	72	0	0	0	0	0	0	0	0	0	12	91	0	0	103	1	1	204	
5:15:00 PM	6	9	6	0	21	1	0	0	55	22	0	77	0	0	0	0	0	0	0	0	0	16	104	0	0	120	0	0	219	
Grand Total	22	54	36	0	112	1	0	0	219	92	0	311	0	0	0	0	0	0	4	1	44	414	0	0	458	2	2	881		
% Approach	19.6%	48.2%	32.1%	0.0%	0.0%	0.0%	0.0%	14.2%	85.8%	0.0%	0.0%	0.0%	0.0%	0.0%	45.1%	41.7%	13.2%	0.0%	0.0%	0.0%	0.0%	0.0%	66.2%	33.8%	0.0%	0.0%	0.0%	0.0%	0.0%	
% Total	2.5%	6.1%	4.1%	0.0%	12.7%	0.0%	0.0%	0.0%	24.9%	10.4%	0.0%	35.3%	0.0%	0.0%	0.0%	0.0%	0.0%	0.0%	0.0%	0.0%	0.0%	5.0%	47.0%	0.0%	0.0%	52.0%	0.0%	0.0%	0.0%	
PHF	0.917	0.794	0.818	0.000	0.875	0.000	0.000	0.000	0.961	0.885	0.000	0.937	0.000	0.000	0.000	0.000	0.000	0.000	0.000	0.000	0.000	0.688	0.924	0.000	0.000	0.954	0.000	0.000	0.937	
Lights	19	53	34	0	106	0	0	0	212	90	0	302	0	0	0	0	0	0	0	0	0	42	405	0	0	447	0	0	855	
% Lights	86.4%	98.1%	94.4%	0.0%	94.6%	0.0%	0.0%	0.0%	96.8%	97.8%	0.0%	97.1%	0.0%	0.0%	0.0%	0.0%	0.0%	0.0%	0.0%	0.0%	0.0%	95.5%	97.8%	0.0%	0.0%	97.6%	0.0%	0.0%	97.0%	
Trucks	0	0	0	0	0	0	0	0	0	0	0	0	0	0	0	0	0	0	0	0	0	0	0	0	0	0	0	0	0	
% Trucks	0.0%	0.0%	0.0%	0.0%	0.0%	0.0%	0.0%	0.0%	0.0%	0.0%	0.0%	0.0%	0.0%	0.0%	0.0%	0.0%	0.0%	0.0%	0.0%	0.0%	0.0%	0.0%	0.0%	0.0%	0.0%	0.0%	0.0%	0.0%	0.0%	
Buses	3	1	2	0	6	0	0	0	7	2	0	9	0	0	0	0	0	0	0	0	0	2	9	0	0	11	0	0	26	
% Buses	13.6%	1.9%	5.6%	0.0%	0.0%	0.0%	0.0%	0.0%	3.2%	2.2%	0.0%	0.0%	0.0%	0.0%	0.0%	0.0%	0.0%	0.0%	0.0%	0.0%	0.0%	4.5%	2.2%	0.0%	0.0%	0.0%	0.0%	0.0%	3.0%	
Pedestrians	0	0	0	0	0	2	1	0	0	0	0	0	0	0	0	4	1	0	0	0	0	0	0	0	0	0	2	2	0	
% Pedestrians	0.0%	0.0%	0.0%	0.0%	0.0%	100.0%	100.0%	0.0%	0.0%	0.0%	0.0%	0.0%	0.0%	0.0%	0.0%	100.0%	100.0%	0.0%	0.0%	0.0%	0.0%	0.0%	0.0%	0.0%	0.0%	0.0%	0.0%	100.0%	100.0%	0.0%
Bicycles on Crosswalk	0	0	0	0	0	0	0	0	0	0	0	0	0	0	0	0	0	0	0	0	0	0	0	0	0	0	0	0	0	
% Bicycles on Crosswalk	0.0%	0.0%	0.0%	0.0%	0.0%	0.0%	0.0%	0.0%	0.0%	0.0%	0.0%	0.0%	0.0%	0.0%	0.0%	0.0%	0.0%	0.0%	0.0%	0.0%	0.0%	0.0%	0.0%	0.0%	0.0%	0.0%	0.0%	0.0%	0.0%	

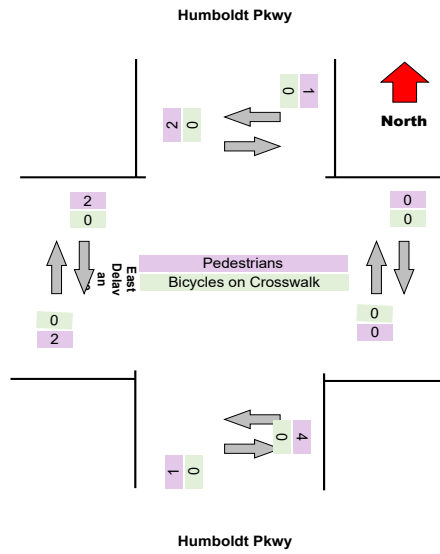
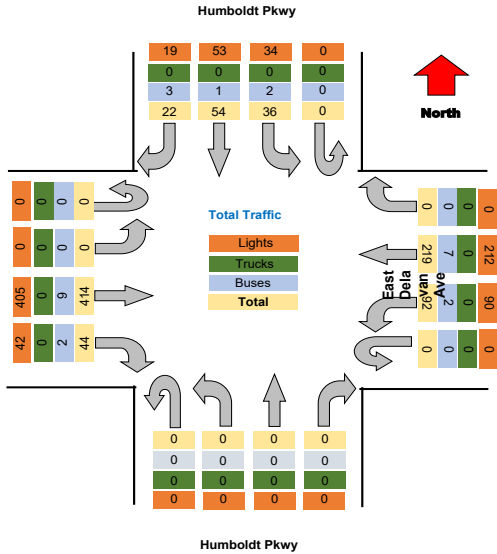

Project : VBH Malta NY
 Site : Site 4
 Location : 42.948550, -73.790036
 Survey Date : 2021-04-28, Wednesday

Turning Movement Data Plot

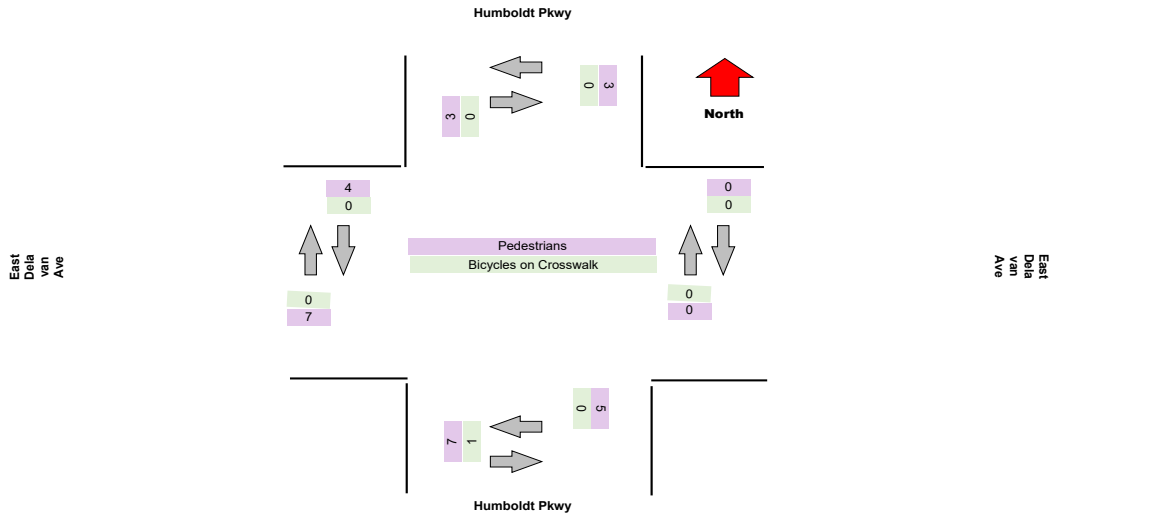
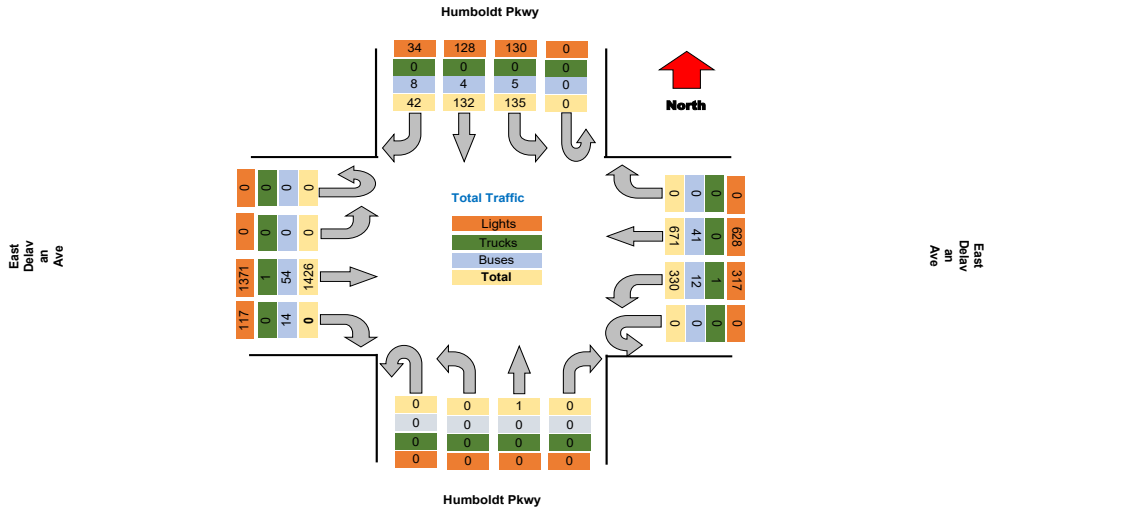

Project : VBH Malta NY
Site : Site 4
Location : 42.948550, -73.790036

TSTData.com

Survey Date : 2021-04-28, Wednesday

Turning Movement Peak Hour Data (AM)

7:30:00 AM

Leg Direction	Humboldt Pkwy					East Delavan Ave					Humboldt Pkwy					East Delavan Ave					Total			
	Southbound		Westbound			Northbound		Eastbound																
Start Time	Right	Thru	Left	U-Turn	App Total	Peds CW	Peds CCW	Right	Thru	Left	U-Turn	App Total	Peds CW	Peds CCW	Right	Thru	Left	U-Turn	App Total	Peds CW	Peds CCW			
7:30:00 AM	4	5	9	0	18	0	0	0	31	21	0	52	0	0	0	0	0	0	0	0	0	0	168	
7:45:00 AM	0	10	6	0	16	1	0	0	52	23	0	75	0	0	0	0	0	0	0	4	107	0	0	202
8:00:00 AM	2	2	4	0	8	0	0	0	44	26	0	70	0	0	0	0	0	0	0	8	90	0	0	178
8:15:00 AM	1	11	6	0	28	0	0	0	41	23	0	65	0	0	0	0	0	0	0	4	91	0	0	180
Grand Total	7	28	27	0	62	1	0	0	168	95	0	264	0	0	0	0	0	0	22	380	0	0	728	
% Approach	11.3%	45.2%	43.5%	0.0%	0.0%	0.0%	0.0%	14.2%	85.8%	0.0%	0.0%	0.0%	0.0%	0.0%	45.1%	41.7%	13.2%	0.0%	0.0%	0.0%	0.0%	0.0%	0.0%	0.0%
% Total	1.0%	3.8%	3.7%	0.0%	8.5%	0.0%	0.0%	0.0%	23.1%	13.0%	0.0%	36.3%	0.0%	0.0%	0.0%	0.0%	0.0%	0.0%	0.0%	0.0%	0.0%	0.0%	0.0%	0.0%
PHF	0.438	0.636	0.750	0.000	0.775	0.000	0.000	0.000	0.808	0.848	0.000	0.880	0.000	0.000	0.000	0.000	0.000	0.000	0.000	0.688	0.888	0.000	0.000	0.901
Lights	6	27	27	0	60	0	0	0	152	92	0	244	0	0	0	0	0	0	0	18	366	0	0	688
% Lights	85.7%	96.4%	100.0%	0.0%	96.8%	0.0%	0.0%	0.0%	90.5%	96.8%	0.0%	92.4%	0.0%	0.0%	0.0%	0.0%	0.0%	0.0%	0.0%	81.8%	96.3%	0.0%	0.0%	95.5%
Trucks	0	0	0	0	0	0	0	0	0	1	0	1	0	0	0	0	0	0	0	0	1	0	0	2
% Trucks	0.0%	0.0%	0.0%	0.0%	0.0%	0.0%	0.0%	0.0%	0.0%	1.1%	0.0%	0.4%	0.0%	0.0%	0.0%	0.0%	0.0%	0.0%	0.0%	0.0%	0.3%	0.0%	0.0%	0.3%
Buses	1	1	0	0	2	0	0	0	16	2	0	18	0	0	0	0	0	0	0	4	13	0	0	37
% Buses	14.3%	3.6%	0.0%	0.0%	0.0%	0.0%	0.0%	0.0%	9.5%	2.1%	0.0%	0.0%	0.0%	0.0%	0.0%	0.0%	0.0%	0.0%	0.0%	18.2%	3.4%	0.0%	0.0%	5.1%
Pedestrians	0	0	0	0	0	1	1	0	0	0	0	0	0	0	0	0	0	0	0	0	0	0	0	0
% Pedestrians	0.0%	0.0%	0.0%	0.0%	0.0%	100.0%	100.0%	0.0%	0.0%	0.0%	0.0%	0.0%	0.0%	0.0%	0.0%	0.0%	0.0%	0.0%	0.0%	0.0%	0.0%	0.0%	0.0%	0.0%
Bicycles on Crosswalk	0	0	0	0	0	0	0	0	0	0	0	0	0	0	0	0	0	0	0	0	0	0	0	0
% Bicycles on Crosswalk	0.0%	0.0%	0.0%	0.0%	0.0%	0.0%	0.0%	0.0%	0.0%	0.0%	0.0%	0.0%	0.0%	0.0%	0.0%	0.0%	0.0%	0.0%	0.0%	0.0%	0.0%	0.0%	0.0%	0.0%

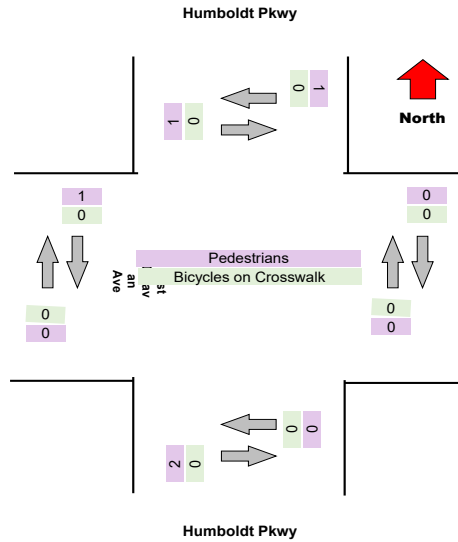
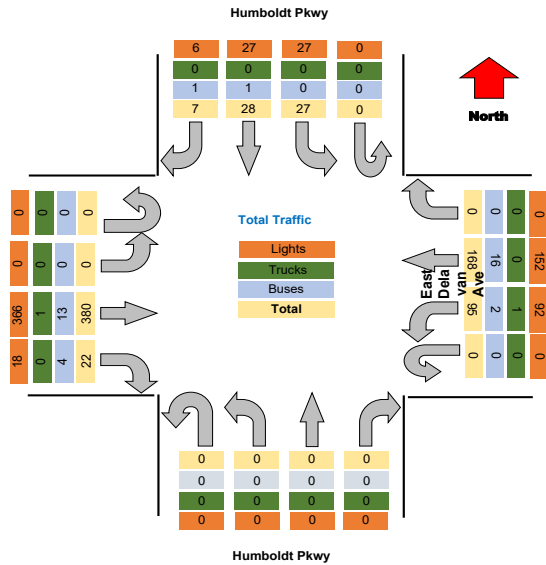

Turning Movement Peak Hour Data (PM)

4:30:00 PM

Leg Direction	Humboldt Pkwy				East Delavan Ave				Humboldt Pkwy				East Delavan Ave				Total							
	Southbound		Northbound		Westbound		Eastbound		Northbound		Southbound		Eastbound											
Start Time	Right	Thru	Left	U-Turn	App Total	Peds CW	Peds CCW	Right	Thru	Left	U-Turn	App Total	Peds CW	Peds CCW	Right	Thru	Left	U-Turn	App Total	Peds CW	Peds CCW			
4:30:00 PM	3	14	18	0	35	0	0	0	61	25	0	86	0	0	0	1	0	0	1	126	0	0	258	
4:45:00 PM	5	12	11	0	28	0	1	0	62	28	0	90	0	0	0	0	0	0	0	12	95	0	0	225
5:00:00 PM	5	11	10	0	26	0	0	0	41	30	0	71	0	0	0	0	0	0	0	13	87	0	0	197
5:15:00 PM	2	7	13	0	22	0	0	0	52	26	0	78	0	0	0	0	0	0	0	16	110	0	0	226
Grand Total	15	44	52	0	111	0	1	0	216	109	0	325	0	0	0	1	0	0	1	51	418	0	0	906
% Approach	13.5%	39.6%	46.8%	0.0%	0.0%	0.0%	0.0%	14.2%	85.8%	0.0%	0.0%	0.0%	0.0%	0.0%	45.1%	41.7%	13.2%	0.0%	0.0%	0.0%	66.2%	33.8%	0.0%	0.0%
% Total	1.7%	4.9%	5.7%	0.0%	12.3%	0.0%	0.0%	0.0%	23.8%	12.0%	0.0%	35.9%	0.0%	0.0%	0.0%	0.1%	0.0%	0.0%	0.0%	5.6%	46.1%	0.0%	0.0%	51.8%
PHF	0.750	0.786	0.722	0.000	0.793	0.000	0.000	0.000	0.871	0.908	0.000	0.903	0.000	0.000	0.000	0.250	0.000	0.000	0.250	0.797	0.829	0.000	0.000	0.882
Lights	10	43	50	0	103	0	0	0	208	108	0	316	0	0	0	0	0	0	0	47	408	0	0	874
% Lights	66.7%	97.7%	96.2%	0.0%	92.8%	0.0%	0.0%	0.0%	96.3%	99.1%	0.0%	97.2%	0.0%	0.0%	0.0%	0.0%	0.0%	0.0%	0.0%	92.2%	97.6%	0.0%	0.0%	96.5%
Trucks	0	0	0	0	0	0	0	0	0	0	0	0	0	0	0	0	0	0	0	0	0	0	0	0
% Trucks	0.0%	0.0%	0.0%	0.0%	0.0%	0.0%	0.0%	0.0%	0.0%	0.0%	0.0%	0.0%	0.0%	0.0%	0.0%	0.0%	0.0%	0.0%	0.0%	0.0%	0.0%	0.0%	0.0%	0.0%
Buses	5	1	2	0	8	0	0	0	7	1	0	8	0	0	0	0	0	0	0	4	10	0	0	30
% Buses	33.3%	2.3%	3.8%	0.0%	0.0%	0.0%	0.0%	0.0%	3.2%	0.9%	0.0%	0.0%	0.0%	0.0%	0.0%	0.0%	0.0%	0.0%	0.0%	7.8%	2.4%	0.0%	0.0%	3.3%
Pedestrians	0	0	0	0	0	0	0	0	0	0	0	0	0	0	2	1	0	0	0	0	0	0	3	1
% Pedestrians	0.0%	0.0%	0.0%	0.0%	0.0%	0.0%	100.0%	0.0%	0.0%	0.0%	0.0%	0.0%	0.0%	0.0%	0.0%	100.0%	100.0%	0.0%	0.0%	0.0%	0.0%	0.0%	0.0%	100.0%
Bicycles on Crosswalk	0	0	0	0	0	0	0	0	0	0	0	0	0	0	0	0	0	0	0	0	0	0	0	0
% Bicycles on Crosswalk	0.0%	0.0%	0.0%	0.0%	0.0%	0.0%	0.0%	0.0%	0.0%	0.0%	0.0%	0.0%	0.0%	0.0%	0.0%	0.0%	0.0%	0.0%	0.0%	0.0%	0.0%	0.0%	0.0%	0.0%

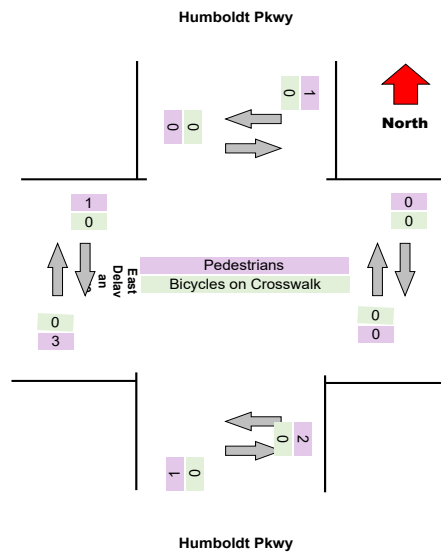
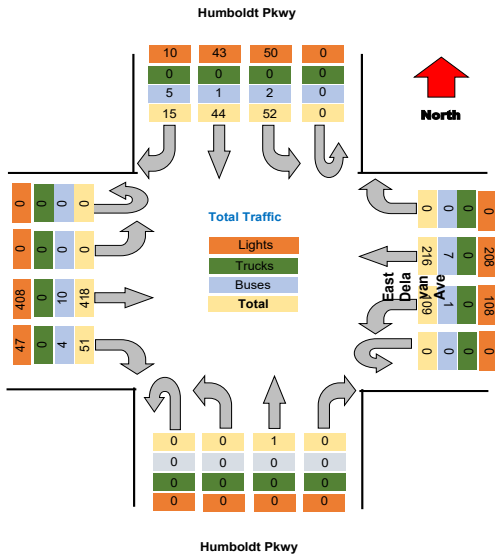

Project : VBH Malta NY
Site : Site 4
Location : 42.948550, -73.790036

TSTData.com

Survey Date : 2021-04-28, Wednesday

Project	LaBella
Project Code	LaBella
Site Name	29
Legs and Movements	All Processed Legs & Move
Bin Size	15 minutes
Survey Date	2021-11-02, Tuesday
Location	29
Latitude and Longitude	42.922152, -78.854005

	Start	End	PHF
Forced Peak AM	2021/11/02 07:30:00	2021/11/02 08:30:00	0.93
Forced Peak PM	2021/11/02 16:30:00	2021/11/02 17:30:00	0.96
AM Peak	2021/11/02 07:30:00	2021/11/02 08:30:00	0.93
PM Peak	2021/11/02 16:30:00	2021/11/02 17:30:00	0.96

Turning Movement Data

Leg Direction	Jefferson Ave										East Delavan Ave										Total											
	Southbound					Westbound					Northbound					Eastbound																
	Right	Thru	Left	U-Turn	App Total	Peds CV	Peds CCV	Right	Thru	Left	U-Turn	App Total	Peds CV	Peds CCV	Right	Thru	Left	U-Turn	App Total	Peds CV		Peds CCV										
Start Time																																
6:30:00 AM	11	8	0	0	19	0	1	3	13	1	0	16	0	0	4	10	4	0	18	0	1	0	0	37	1	0	38	0	0	93		
6:45:00 AM	11	8	0	0	17	0	1	3	10	0	0	14	2	0	8	8	2	0	20	1	0	0	0	3	43	2	0	48	0	1	99	
Hourly Total	22	14	0	0	36	0	2	6	23	1	0	32	2	0	12	18	6	0	39	1	1	0	0	3	89	3	0	96	0	1	192	
7:00:00 AM	16	9	1	1	17	0	0	0	19	2	0	21	0	1	8	9	6	0	24	0	0	0	0	1	43	2	0	46	0	0	108	
7:15:00 AM	9	6	1	0	16	0	1	3	15	4	0	23	0	0	6	13	5	0	24	0	0	0	0	4	46	5	0	55	0	0	118	
7:30:00 AM	6	9	1	0	16	1	0	1	23	5	0	29	0	2	4	15	5	0	26	1	1	0	0	3	77	9	0	89	0	0	160	
7:45:00 AM	10	11	1	0	22	0	1	3	11	6	0	21	0	1	4	18	6	0	29	0	0	0	0	6	70	9	0	85	0	1	157	
Hourly Total	31	35	4	1	71	1	2	7	68	17	0	94	0	4	22	55	22	0	103	1	1	0	0	14	236	25	0	275	0	1	543	
8:00:00 AM	22	13	1	0	36	0	1	3	12	2	0	18	0	1	6	12	5	0	24	0	0	0	0	10	56	10	0	76	5	0	154	
8:15:00 AM	24	12	2	0	38	0	0	4	17	6	0	27	0	0	4	11	4	0	19	0	0	0	0	9	71	8	0	88	3	2	172	
Hourly Total	46	25	3	0	74	0	1	7	29	8	0	45	0	1	10	23	9	0	43	0	0	0	0	19	127	18	0	164	8	2	326	
4:00:00 PM	16	20	2	0	38	1	1	8	34	12	0	54	1	0	14	26	6	0	46	4	1	0	0	11	62	20	0	93	0	0	231	
4:15:00 PM	14	28	5	0	47	1	0	8	24	15	1	48	4	1	24	29	5	0	58	0	2	0	0	19	64	20	0	103	3	0	256	
4:30:00 PM	7	27	3	0	37	2	0	4	29	11	0	44	4	3	19	20	10	0	49	2	2	0	0	17	73	17	0	107	1	0	237	
4:45:00 PM	11	22	4	0	37	1	0	6	24	7	0	37	2	2	13	25	10	0	48	0	1	0	0	12	58	15	0	85	0	0	207	
Hourly Total	48	97	14	0	159	5	1	26	111	45	1	183	11	6	70	100	31	0	201	6	6	0	0	59	257	72	0	338	4	0	931	
5:00:00 PM	11	26	5	0	42	0	0	8	27	9	0	44	2	0	10	32	7	0	49	0	0	0	0	17	80	21	0	98	2	1	233	
5:15:00 PM	20	19	3	0	42	0	0	5	22	11	0	38	3	3	14	24	6	0	44	2	1	0	0	16	81	14	0	111	0	2	235	
5:30:00 PM	10	21	3	0	34	2	0	9	36	10	0	55	0	2	17	23	7	1	48	0	1	0	0	10	62	17	0	89	0	3	226	
5:45:00 PM	13	21	5	0	39	1	1	3	29	7	0	39	1	0	7	25	7	0	39	0	0	0	0	10	56	14	0	80	0	1	197	
Hourly Total	54	87	16	0	157	3	1	25	114	37	0	176	6	5	48	104	27	1	180	2	2	0	0	53	259	66	0	378	2	7	891	
Grand Total	201	258	37	1	497	5	7	71	345	108	1	530	15	16	162	300	95	1	565	10	10	0	0	148	959	184	0	1291	14	11	2883	
% Approach	40.4%	51.9%	7.4%	0.2%	0.0%	0.0%	0.0%	13.4%	65.1%	20.4%	0.2%	0.0%	0.0%	0.0%	28.7%	53.1%	16.8%	0.2%	0.0%	0.0%	0.0%	0.0%	0.0%	11.5%	74.3%	14.3%	0.0%	0.0%	0.0%	0.0%	0.0%	
% Total	7.0%	8.9%	1.3%	0.0%	17.2%	0.0%	0.0%	2.5%	12.0%	3.7%	0.0%	18.4%	0.0%	0.0%	5.6%	10.4%	3.3%	0.0%	19.6%	0.0%	0.0%	0.0%	0.0%	5.1%	33.3%	6.4%	0.0%	44.8%	0.0%	0.0%	0.0%	
Lights	198	256	37	1	492	0	0	68	333	107	1	509	0	0	158	294	87	1	540	0	0	0	0	140	935	182	0	1257	0	0	2798	
% Lights	98.5%	99.2%	100.0%	100.0%	99.0%	0.0%	0.0%	95.9%	96.9%	99.1%	100.0%	98.0%	0.0%	0.0%	97.5%	98.0%	91.6%	100.0%	95.6%	0.0%	0.0%	0.0%	0.0%	94.6%	97.5%	98.9%	0.0%	97.4%	0.0%	0.0%	97.1%	
Trucks	0	0	0	0	0	0	0	0	0	0	0	0	0	0	0	0	0	0	0	0	0	0	0	0	0	0	0	0	0	0	0	
% Trucks	0.0%	0.0%	0.0%	0.0%	0.0%	0.0%	0.0%	0.0%	0.0%	0.0%	0.0%	0.0%	0.0%	0.0%	0.0%	0.0%	0.0%	0.0%	0.0%	0.0%	0.0%	0.0%	0.0%	0.0%	0.0%	0.0%	0.0%	0.0%	0.0%	0.0%	0.0%	
Buses	3	2	0	0	5	0	0	3	11	0	0	14	0	0	4	6	8	0	18	0	0	0	0	8	22	2	0	32	0	0	69	
% Buses	1.5%	0.8%	0.0%	0.0%	0.0%	0.0%	0.0%	0.0%	3.2%	0.0%	0.0%	0.0%	0.0%	0.0%	2.5%	2.0%	8.4%	0.0%	0.0%	0.0%	0.0%	0.0%	0.0%	5.4%	2.3%	1.1%	0.0%	0.0%	0.0%	0.0%	2.4%	
Pedestrians	0	0	0	0	0	9	7	0	0	0	0	0	19	16	0	0	0	0	0	10	10	0	0	0	0	0	0	0	14	10	0	
% Pedestrians	0.0%	0.0%	0.0%	0.0%	0.0%	100.0%	100.0%	0.0%	0.0%	0.0%	0.0%	0.0%	100.0%	100.0%	0.0%	0.0%	0.0%	0.0%	0.0%	100.0%	100.0%	0.0%	0.0%	0.0%	0.0%	0.0%	0.0%	0.0%	0.0%	80.8%	0.0%	0.0%
Bicycles on Crosswalk	0	0	0	0	0	0	0	0	0	0	0	0	0	0	0	0	0	0	0	0	0	0	0	0	0	0	0	0	0	1	0	
% Bicycles on Crosswalk	0.0%	0.0%	0.0%	0.0%	0.0%	0.0%	0.0%	0.0%	0.0%	0.0%	0.0%	0.0%	0.0%	0.0%	0.0%	0.0%	0.0%	0.0%	0.0%	0.0%	0.0%	0.0%	0.0%	0.0%	0.0%	0.0%	0.0%	0.0%	0.0%	9.1%	0.0%	

Project : VBH Malta NY
 Site : Site 4
 Location : 42.948550, -73.790036
 Survey Date : 2021-04-28, Wednesday

Turning Movement Data Plot

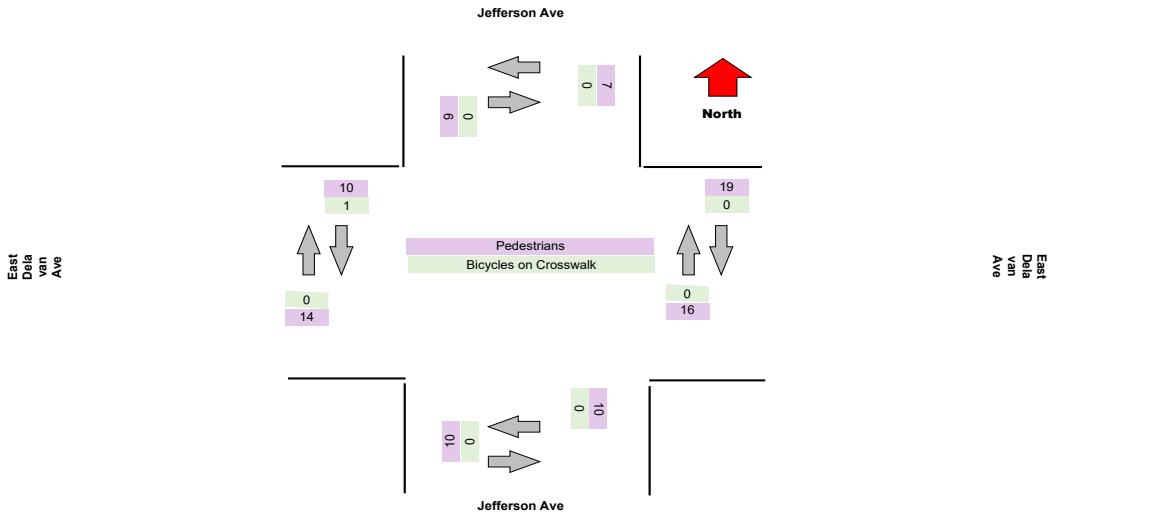
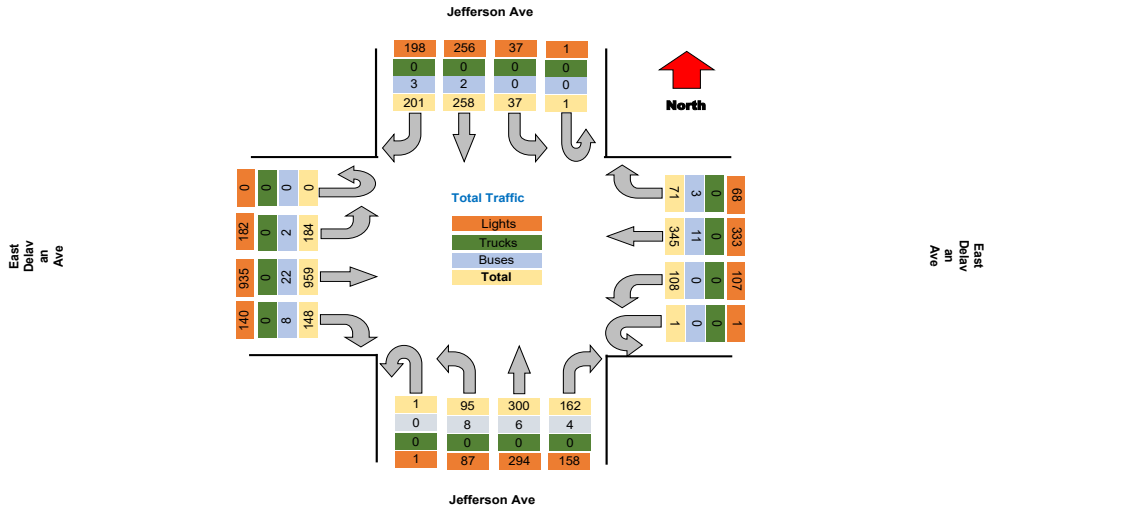

Turning Movement Peak Hour Data (AM)

7:30:00 AM

Leg Direction	Jefferson Ave								East Delavan Ave								Jefferson Ave								East Delavan Ave								Total
	Southbound				Westbound				Northbound				Eastbound				Southbound				Westbound				Northbound				Eastbound				
	Right	Thru	Left	U-Turn	App Total	Peds CW	Peds CCW		Right	Thru	Left	U-Turn	App Total	Peds CW	Peds CCW		Right	Thru	Left	U-Turn	App Total	Peds CW	Peds CCW		Right	Thru	Left	U-Turn	App Total	Peds CW	Peds CCW		
7:30:00 AM	6	9	1	0	16	1	0		1	23	5	0	29	0	2		4	15	5	0	26	1	1		3	77	9	0	89	0	0		160
7:45:00 AM	10	11	1	0	22	0	1		3	11	6	0	21	0	1		4	18	6	0	29	0	0		6	70	9	0	85	0	1		157
8:00:00 AM	22	13	1	0	36	0	1		3	12	2	0	18	0	1		6	12	5	0	24	0	0		10	56	10	0	76	5	0		154
8:15:00 AM	24	12	2	0	38	0	0		4	17	6	0	27	0	0		4	11	4	0	19	0	0		9	71	8	0	88	3	2		172
Grand Total	62	45	5	0	112	1	0		11	63	19	0	93	0	4		18	55	20	0	93	1	1		29	274	36	0	338	3	3		643
% Approach	55.4%	40.2%	4.5%	0.0%	0.0%	0.0%	0.0%		11.6%	66.3%	20.0%	0.0%	0.6%	0.0%	0.0%		18.4%	57.1%	20.4%	0.0%	0.0%	0.0%	0.0%		8.3%	81.1%	10.7%	0.0%	0.0%	0.0%	0.0%		0.0%
% Total	9.6%	7.0%	0.8%	0.0%	17.4%	0.0%	0.0%		1.7%	8.8%	3.0%	0.0%	14.8%	0.0%	0.0%		2.8%	8.7%	3.1%	0.0%	15.2%	0.0%	0.0%		4.4%	42.6%	5.6%	0.0%	62.6%	0.0%	0.0%		0.0%
PHF	0.646	0.865	0.625	0.000	0.737	0.000	0.000		0.688	0.685	0.792	0.000	0.819	0.000	0.000		0.750	0.778	0.833	0.000	0.845	0.000	0.000		0.700	0.890	0.900	0.000	0.949	0.000	0.000		0.935
Lights	62	45	5	0	112	0	0		10	60	19	0	89	0	0		18	55	18	0	91	0	0		26	268	35	0	329	0	0		621
% Lights	100.0%	100.0%	100.0%	0.0%	100.0%	0.0%	0.0%		90.9%	95.2%	100.0%	0.0%	93.7%	0.0%	0.0%		100.0%	98.2%	90.0%	0.0%	92.9%	0.0%	0.0%		92.9%	97.8%	97.2%	0.0%	97.3%	0.0%	0.0%		96.6%
Trucks	0	0	0	0	0	0	0		0	0	0	0	0	0	0		0	0	0	0	0	0	0		0	0	0	0	0	0	0		0
% Trucks	0.0%	0.0%	0.0%	0.0%	0.0%	0.0%	0.0%		0.0%	0.0%	0.0%	0.0%	0.0%	0.0%	0.0%		0.0%	0.0%	0.0%	0.0%	0.0%	0.0%	0.0%		0.0%	0.0%	0.0%	0.0%	0.0%	0.0%	0.0%		0.0%
Buses	0	0	0	0	0	0	0		1	3	0	0	4	0	0		0	1	2	0	3	0	0		2	6	1	0	9	0	0		16
% Buses	0.0%	0.0%	0.0%	0.0%	0.0%	0.0%	0.0%		9.1%	4.8%	0.0%	0.0%	0.0%	0.0%	0.0%		0.0%	1.8%	10.0%	0.0%	0.0%	0.0%	0.0%		7.1%	2.2%	2.8%	0.0%	0.0%	0.0%	0.0%		2.5%
Pedestrians	0	0	0	0	0	1	2		0	0	0	0	0	0	4		0	0	0	0	0	1	1		0	0	0	0	0	8	3		0
% Pedestrians	0.0%	0.0%	0.0%	0.0%	0.0%	100.0%	100.0%		0.0%	0.0%	0.0%	0.0%	0.0%	0.0%	100.0%		0.0%	0.0%	0.0%	0.0%	0.0%	100.0%	100.0%		0.0%	0.0%	0.0%	0.0%	0.0%	100.0%	100.0%		0.0%
Bicycles on Crosswalk	0	0	0	0	0	0	0		0	0	0	0	0	0	0		0	0	0	0	0	0	0		0	0	0	0	0	0	0		0
% Bicycles on Crosswalk	0.0%	0.0%	0.0%	0.0%	0.0%	0.0%	0.0%		0.0%	0.0%	0.0%	0.0%	0.0%	0.0%	0.0%		0.0%	0.0%	0.0%	0.0%	0.0%	0.0%	0.0%		0.0%	0.0%	0.0%	0.0%	0.0%	0.0%	0.0%		0.0%

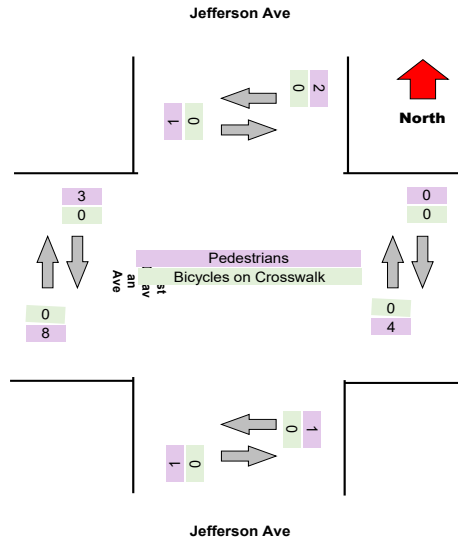
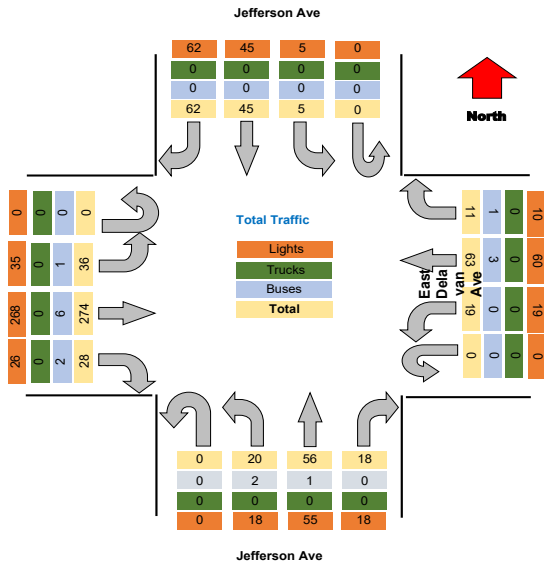

Turning Movement Peak Hour Data (PM)

4:30:00 PM

Leg Direction	Jefferson Ave								East Delavan Ave								Jefferson Ave								East Delavan Ave								Total
	Southbound				Westbound				Northbound				Eastbound				Southbound				Westbound												
	Right	Thru	Left	U-Turn	App Total	Peds CW	Peds CCW		Right	Thru	Left	U-Turn	App Total	Peds CW	Peds CCW		Right	Thru	Left	U-Turn	App Total	Peds CW	Peds CCW		Right	Thru	Left	U-Turn	App Total	Peds CW	Peds CCW		
4:30:00 PM	7	27	3	0	37	2	0	0	4	29	11	0	44	4	3	0	19	20	10	0	49	2	2	0	17	73	17	0	107	1	0	0	237
4:45:00 PM	11	22	4	0	37	1	0	0	6	24	7	0	37	2	2	0	13	25	10	0	48	0	1	0	12	58	15	0	85	0	0	0	207
5:00:00 PM	11	26	5	0	42	0	0	0	8	27	9	0	44	2	0	0	10	32	7	0	49	0	0	0	17	60	21	0	98	2	1	0	233
5:15:00 PM	20	19	3	0	42	0	0	0	5	22	11	0	38	3	3	0	14	24	6	0	44	2	1	0	16	81	14	0	111	0	2	0	235
Grand Total	49	94	15	0	158	3	0	0	23	102	38	0	153	11	6	0	55	101	33	0	190	4	4	0	62	272	67	0	401	3	3	0	912
% Approach	31.0%	59.5%	9.5%	0.0%	0.0%	0.0%	0.0%	0.0%	14.1%	62.6%	23.3%	0.0%	0.0%	0.0%	0.0%	0.0%	25.5%	53.2%	17.4%	0.0%	0.0%	0.0%	0.0%	0.0%	15.5%	67.8%	16.7%	0.0%	0.0%	0.0%	0.0%	0.0%	
% Total	5.4%	10.3%	1.6%	0.0%	17.3%	0.0%	0.0%	0.0%	2.5%	11.2%	4.2%	0.0%	17.9%	0.0%	0.0%	0.0%	6.1%	11.1%	3.6%	0.0%	20.8%	0.0%	0.0%	0.0%	6.8%	29.8%	7.3%	0.0%	44.0%	0.0%	0.0%	0.0%	
PHF	0.613	0.870	0.750	0.000	0.940	0.000	0.000	0.000	0.719	0.879	0.864	0.000	0.926	0.000	0.000	0.000	0.737	0.789	0.825	0.000	0.869	0.000	0.000	0.000	0.912	0.840	0.798	0.000	0.903	0.000	0.000	0.000	0.962
Lights	48	94	15	0	157	0	0	0	23	98	37	0	158	0	0	0	56	99	31	0	186	0	0	0	60	267	67	0	394	0	0	0	895
% Lights	98.0%	100.0%	100.0%	0.0%	99.4%	0.0%	0.0%	0.0%	100.0%	96.1%	97.4%	0.0%	96.9%	0.0%	0.0%	0.0%	100.0%	98.0%	93.9%	0.0%	97.9%	0.0%	0.0%	0.0%	96.8%	98.2%	100.0%	0.0%	98.3%	0.0%	0.0%	0.0%	98.1%
Trucks	0	0	0	0	0	0	0	0	0	0	0	0	0	0	0	0	0	0	0	0	0	0	0	0	0	0	0	0	0	0	0	0	0
% Trucks	0.0%	0.0%	0.0%	0.0%	0.0%	0.0%	0.0%	0.0%	0.0%	0.0%	0.0%	0.0%	0.0%	0.0%	0.0%	0.0%	0.0%	0.0%	0.0%	0.0%	0.0%	0.0%	0.0%	0.0%	0.0%	0.0%	0.0%	0.0%	0.0%	0.0%	0.0%	0.0%	0.0%
Buses	1	0	0	0	1	0	0	0	0	3	0	0	3	0	0	0	0	2	2	0	4	0	0	0	2	3	0	0	5	0	0	0	13
% Buses	2.0%	0.0%	0.0%	0.0%	0.0%	0.0%	0.0%	0.0%	0.0%	2.9%	0.0%	0.0%	0.0%	0.0%	0.0%	0.0%	0.0%	2.0%	6.1%	0.0%	0.0%	0.0%	0.0%	0.0%	3.2%	1.1%	0.0%	0.0%	0.0%	0.0%	0.0%	0.0%	1.4%
Pedestrians	0	0	0	0	3	0	0	0	0	0	0	0	11	6	0	0	0	0	0	0	4	4	0	0	0	0	0	0	8	3	2	0	20
% Pedestrians	0.0%	0.0%	0.0%	0.0%	0.0%	100.0%	0.0%	0.0%	0.0%	0.0%	0.0%	0.0%	0.0%	100.0%	100.0%	0.0%	0.0%	0.0%	0.0%	0.0%	0.0%	100.0%	100.0%	0.0%	0.0%	0.0%	0.0%	0.0%	0.0%	100.0%	66.7%	0.0%	
Bicycles on Crosswalk	0	0	0	0	0	0	0	0	0	0	0	0	0	0	0	0	0	0	0	0	0	0	0	0	0	0	0	0	0	0	1	0	1
% Bicycles on Crosswalk	0.0%	0.0%	0.0%	0.0%	0.0%	0.0%	0.0%	0.0%	0.0%	0.0%	0.0%	0.0%	0.0%	0.0%	0.0%	0.0%	0.0%	0.0%	0.0%	0.0%	0.0%	0.0%	0.0%	0.0%	0.0%	0.0%	0.0%	0.0%	0.0%	0.0%	33.3%	0.0%	

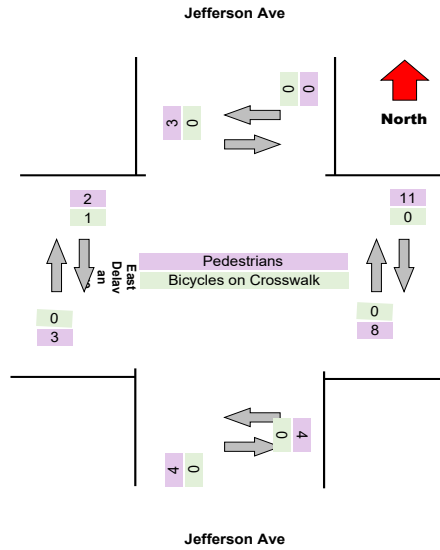
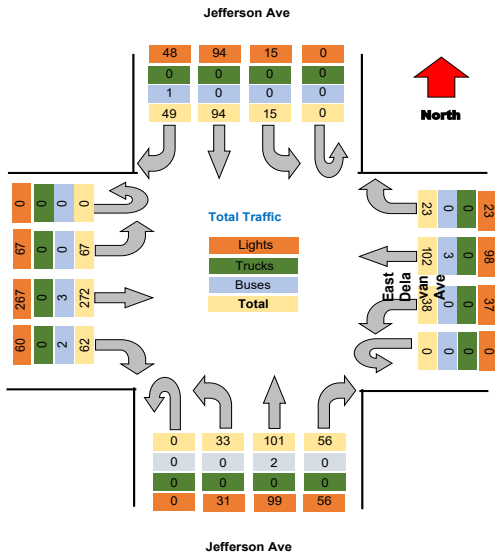

Project : VBH Malta NY
 Site : Site 4
 Location : 42.948550, -73.790036
 Survey Date : 2021-04-28, Wednesday

Turning Movement Data Plot

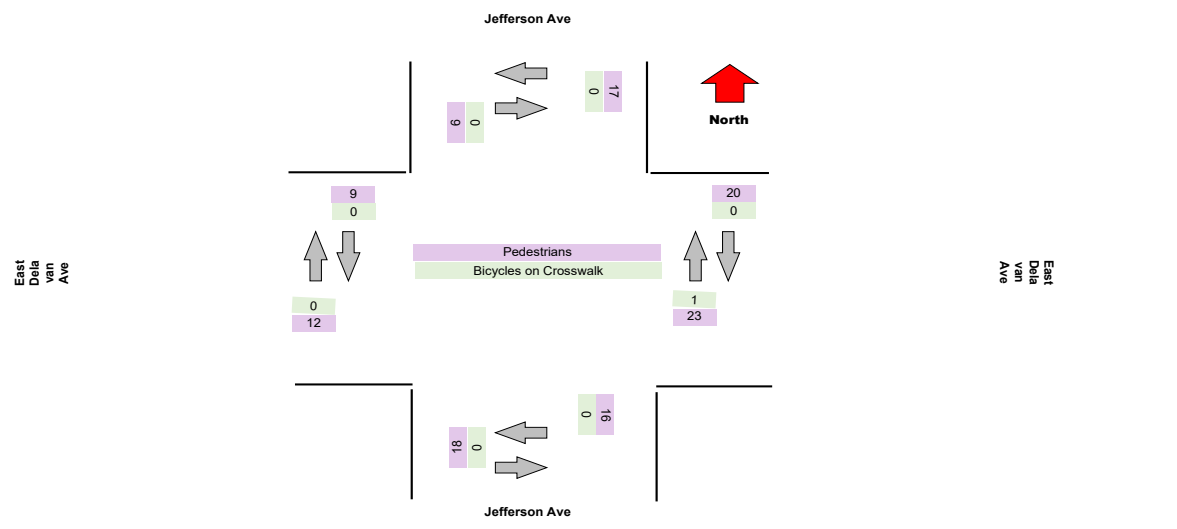
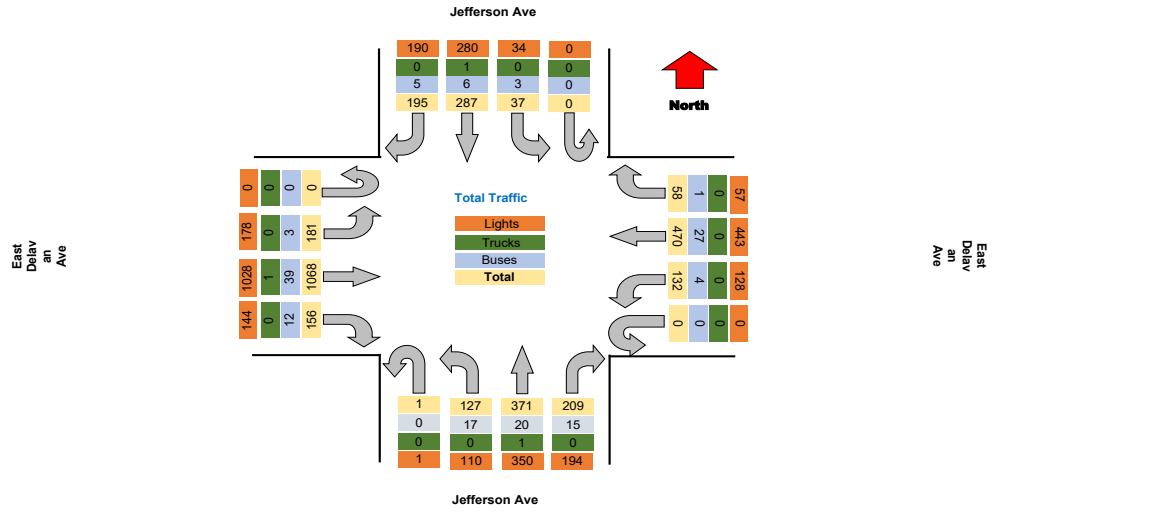

Turning Movement Peak Hour Data (AM)

7:30:00 AM

Leg Direction	Jefferson Ave					East Delavan Ave					Jefferson Ave					East Delavan Ave					Total
	Southbound		Westbound			Northbound		Eastbound			Southbound		Westbound			Northbound		Eastbound			
Start Time	Right	Thru	Left	U-Turn	App Total	Peds CW	Peds CCW	Right	Thru	Left	U-Turn	App Total	Peds CW	Peds CCW	Right	Thru	Left	U-Turn	App Total	Peds CW	Peds CCW
7:30:00 AM	12	15	1	0	28	0	0	1	24	3	0	28	1	1	8	22	4	0	36	0	0
7:45:00 AM	17	30	1	0	48	0	4	3	47	9	0	63	0	1	18	17	7	0	43	1	0
8:00:00 AM	22	12	2	0	36	0	0	6	23	6	0	35	0	1	8	24	8	0	41	0	2
8:15:00 AM	23	10	1	0	34	1	5	4	36	7	0	52	0	0	13	21	7	0	41	0	0
Grand Total	74	67	5	0	146	1	9	14	120	24	0	178	1	2	47	84	26	0	151	1	2
% Approach	50.7%	45.9%	3.4%	0.0%	0.0%	0.0%	0.0%	7.9%	73.0%	14.0%	0.0%	0.0%	0.0%	0.0%	29.2%	52.2%	16.1%	0.0%	0.0%	0.0%	0.0%
% Total	8.7%	7.9%	0.6%	0.0%	17.1%	0.0%	0.0%	1.6%	15.2%	2.9%	0.0%	20.9%	0.0%	0.0%	5.5%	9.8%	3.0%	0.0%	18.9%	0.0%	0.0%
PHF	0.804	0.558	0.625	0.000	0.760	0.000	0.000	0.583	0.691	0.694	0.000	0.706	0.000	0.000	0.653	0.875	0.813	0.000	0.936	0.000	0.000
Lights	72	67	5	0	144	0	0	14	120	24	0	158	0	0	43	79	19	0	141	0	0
% Lights	87.3%	100.0%	100.0%	0.0%	98.6%	0.0%	0.0%	100.0%	92.3%	96.0%	0.0%	88.8%	0.0%	0.0%	81.5%	94.0%	73.1%	0.0%	87.6%	0.0%	0.0%
Trucks	0	0	0	0	0	0	0	0	0	0	0	0	0	0	0	0	0	0	0	0	0
% Trucks	0.0%	0.0%	0.0%	0.0%	0.0%	0.0%	0.0%	0.0%	0.0%	0.0%	0.0%	0.0%	0.0%	0.0%	0.0%	0.0%	0.0%	0.0%	0.0%	0.0%	0.0%
Buses	2	0	0	0	2	0	0	0	10	1	0	11	0	0	4	5	7	0	16	0	0
% Buses	2.7%	0.0%	0.0%	0.0%	0.0%	0.0%	0.0%	0.0%	7.7%	4.0%	0.0%	0.0%	0.0%	0.0%	8.5%	6.0%	28.9%	0.0%	0.0%	0.0%	0.0%
Pedestrians	0	0	0	0	0	1	9	0	0	0	0	1	3	0	0	0	0	0	1	2	0
% Pedestrians	0.0%	0.0%	0.0%	0.0%	0.0%	100.0%	100.0%	0.0%	0.0%	0.0%	0.0%	0.0%	100.0%	100.0%	0.0%	0.0%	0.0%	0.0%	0.0%	100.0%	100.0%
Bicycles on Crosswalk	0	0	0	0	0	0	0	0	0	0	0	0	0	0	0	0	0	0	0	0	0
% Bicycles on Crosswalk	0.0%	0.0%	0.0%	0.0%	0.0%	0.0%	0.0%	0.0%	0.0%	0.0%	0.0%	0.0%	0.0%	0.0%	0.0%	0.0%	0.0%	0.0%	0.0%	0.0%	0.0%

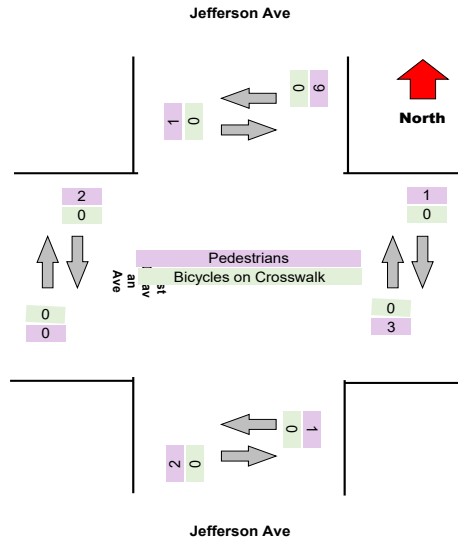
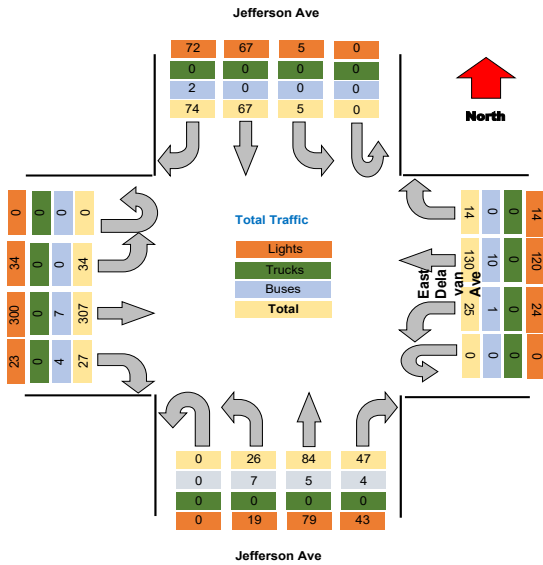

Turning Movement Peak Hour Data (PM)

4:30:00 PM

Leg Direction	Jefferson Ave					East Delavan Ave					Jefferson Ave					East Delavan Ave					Total
	Right	Thru	Left	U-Turn	App Total	Right	Thru	Left	U-Turn	App Total	Right	Thru	Left	U-Turn	App Total	Right	Thru	Left	U-Turn	App Total	
4:30:00 PM	13	27	3	0	43	2	35	15	0	52	14	27	13	0	54	17	85	22	0	124	
4:45:00 PM	9	17	5	0	31	7	40	11	0	58	21	31	11	0	66	9	65	10	0	84	
5:00:00 PM	5	26	3	0	34	10	24	10	0	44	14	43	9	0	73	12	76	29	0	117	
5:15:00 PM	11	25	0	0	36	2	29	13	0	44	14	29	8	1	53	9	67	17	0	93	
Grand Total	38	85	11	0	144	21	128	49	0	198	63	130	42	1	236	47	293	78	0	418	
% Approach	26.4%	66.0%	7.6%	0.0%	0.0%	10.6%	64.6%	24.7%	0.0%	0.0%	26.7%	55.1%	17.8%	0.4%	0.0%	11.2%	70.1%	18.7%	0.0%	0.0%	
% Total	3.8%	9.5%	1.1%	0.0%	14.5%	2.1%	12.9%	4.9%	0.0%	19.9%	6.3%	13.1%	4.2%	0.1%	23.7%	4.7%	29.4%	7.8%	0.0%	42.0%	
PHF	0.731	0.880	0.550	0.000	0.837	0.525	0.800	0.817	0.000	0.853	0.750	0.756	0.808	0.250	0.808	0.691	0.862	0.672	0.000	0.843	
Lights	37	92	11	0	140	21	122	49	0	192	59	125	39	1	224	45	285	77	0	407	
% Lights	97.4%	96.8%	100.0%	0.0%	97.2%	100.0%	95.3%	100.0%	0.0%	97.0%	93.7%	96.2%	92.9%	100.0%	94.9%	95.7%	97.3%	98.7%	0.0%	97.4%	
Trucks	0	0	0	0	0	0	0	0	0	0	0	1	0	0	1	0	0	0	0	0	
% Trucks	0.0%	0.0%	0.0%	0.0%	0.0%	0.0%	0.0%	0.0%	0.0%	0.0%	0.0%	0.8%	0.0%	0.0%	0.4%	0.0%	0.0%	0.0%	0.0%	0.0%	
Buses	1	3	0	0	4	6	0	0	0	6	4	4	3	0	11	2	8	1	0	11	
% Buses	2.6%	3.2%	0.0%	0.0%	0.0%	4.7%	0.0%	0.0%	0.0%	0.0%	6.3%	3.1%	7.1%	0.0%	0.0%	4.3%	2.7%	1.3%	0.0%	0.0%	
Pedestrians	0	0	0	0	0	0	0	0	0	0	0	0	0	0	4	0	0	0	0	0	
% Pedestrians	0.0%	0.0%	0.0%	0.0%	0.0%	0.0%	0.0%	0.0%	0.0%	0.0%	0.0%	0.0%	0.0%	0.0%	0.0%	0.0%	0.0%	0.0%	0.0%	0.0%	
Bicycles on Crosswalk	0	0	0	0	0	0	0	0	0	0	0	0	0	0	0	0	0	0	0	0	
% Bicycles on Crosswalk	0.0%	0.0%	0.0%	0.0%	0.0%	0.0%	0.0%	0.0%	0.0%	0.0%	0.0%	0.0%	0.0%	0.0%	0.0%	0.0%	0.0%	0.0%	0.0%	0.0%	

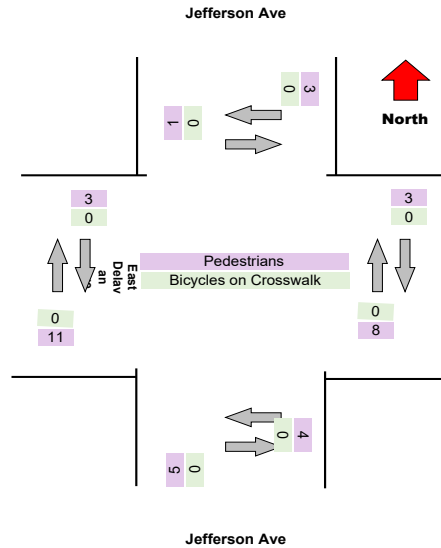
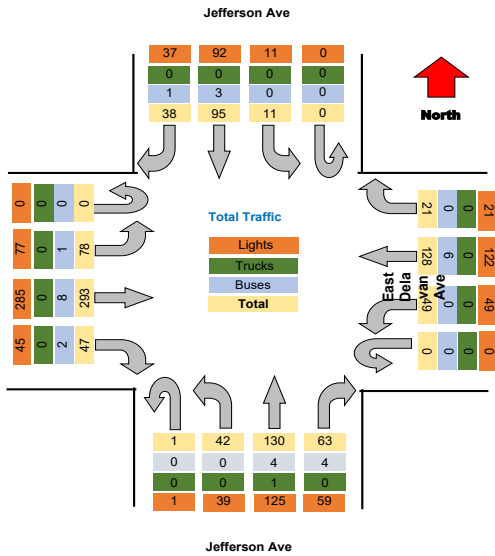

Project : VBH Malta NY
 Site : Site 4
 Location : 42.948550, -73.790036
 Survey Date : 2021-04-28, Wednesday

Turning Movement Data Plot

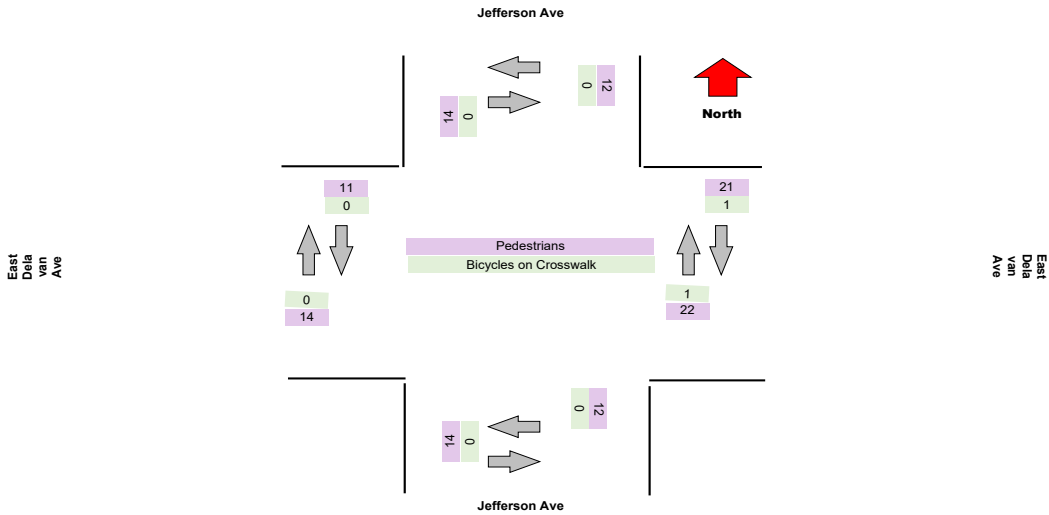
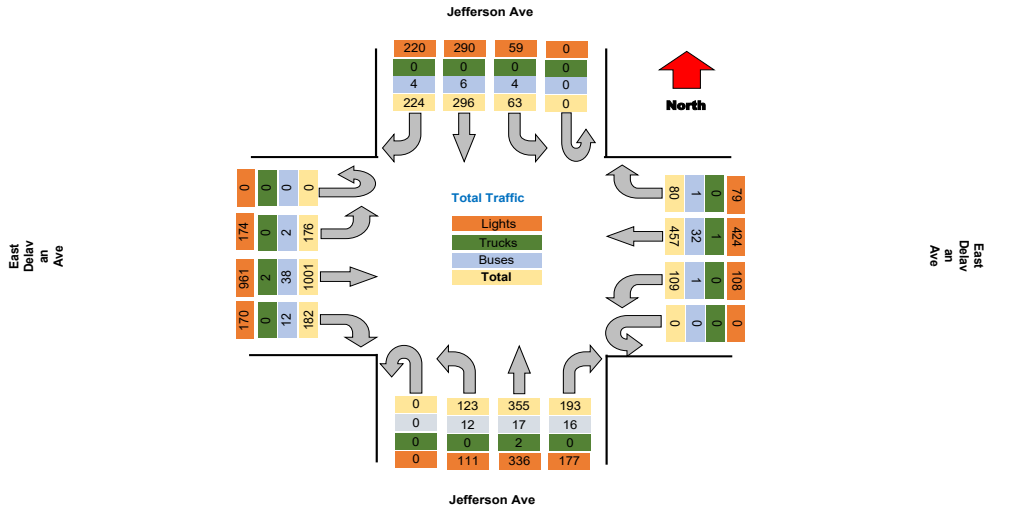

Turning Movement Peak Hour Data (AM)

7:30:00 AM

Leg Direction	Jefferson Ave										East Delavan Ave										Jefferson Ave										East Delavan Ave										Total										
	Southbound					Westbound					Northbound					Eastbound					Southbound					Westbound					Northbound					Eastbound															
	Right	Thru	Left	U-Turn	App Total	Right	Thru	Left	U-Turn	App Total	Right	Thru	Left	U-Turn	App Total	Right	Thru	Left	U-Turn	App Total	Right	Thru	Left	U-Turn	App Total	Right	Thru	Left	U-Turn	App Total	Right	Thru	Left	U-Turn	App Total	Right	Thru	Left	U-Turn	App Total											
7:30:00 AM	9	16	3	0	28	0	0	0	0	0	1	22	4	0	27	0	0	0	0	0	9	14	6	0	29	2	2	0	0	4	9	90	3	0	102	1	0	0	0	1	0	0	0	0	0	0	0	0	0	0	186
7:45:00 AM	16	15	3	0	34	1	2	0	0	3	6	40	6	0	54	0	0	0	0	0	12	22	7	0	41	0	1	0	0	1	10	77	11	0	98	2	0	0	0	2	0	0	0	0	0	227					
8:00:00 AM	13	19	4	0	36	0	1	0	0	1	8	26	10	0	44	0	1	0	0	1	10	21	9	0	41	0	1	0	0	1	14	68	9	0	91	1	1	0	0	2	0	0	0	0	0	213					
8:15:00 AM	21	16	0	0	37	0	0	0	0	0	3	29	6	0	37	0	2	0	0	2	16	19	6	0	43	0	0	0	0	0	6	56	6	0	68	3	2	0	0	5	0	0	0	0	0	187					
Grand Total	59	68	10	0	137	1	3	0	0	4	18	116	26	0	153	0	3	0	0	3	47	76	28	0	154	2	2	0	0	4	39	291	29	0	359	7	3	0	0	10	0	0	0	0	0	813					
% Approach	43.1%	49.6%	7.3%	0.0%	0.0%	11.0%	71.2%	16.0%	0.0%	0.0%	30.5%	49.4%	16.2%	0.0%	0.0%	10.9%	81.1%	8.1%	0.0%	0.0%	10.9%	81.1%	8.1%	0.0%	0.0%	10.9%	81.1%	8.1%	0.0%	0.0%	10.9%	81.1%	8.1%	0.0%	0.0%	10.9%	81.1%	8.1%	0.0%	0.0%											
% Total	7.3%	8.4%	1.2%	0.0%	16.9%	2.2%	14.3%	3.2%	0.0%	20.0%	5.8%	9.3%	3.4%	0.0%	18.9%	4.8%	35.8%	3.6%	0.0%	44.2%	4.8%	35.8%	3.6%	0.0%	44.2%	4.8%	35.8%	3.6%	0.0%	44.2%	4.8%	35.8%	3.6%	0.0%	44.2%	4.8%	35.8%	3.6%	0.0%	44.2%											
PHF	0.702	0.895	0.625	0.000	0.878	0.563	0.725	0.650	0.000	0.755	0.734	0.864	0.778	0.000	0.895	0.696	0.808	0.659	0.000	0.880	0.696	0.808	0.659	0.000	0.880	0.696	0.808	0.659	0.000	0.880	0.696	0.808	0.659	0.000	0.880	0.696	0.808	0.659	0.000	0.880											
Lights	57	68	9	0	134	18	104	26	0	148	40	70	24	0	134	35	284	29	0	348																															
% Trucks	96.6%	100.0%	90.0%	0.0%	97.8%	100.0%	89.7%	100.0%	0.0%	90.8%	85.1%	92.1%	85.7%	0.0%	87.0%	89.7%	97.6%	100.0%	0.0%	96.9%																															
Buses	2	0	1	0	3	0	12	0	0	12	7	5	4	0	16	4	6	0	0	10																															
% Pedestrians	0.0%	0.0%	0.0%	0.0%	0.0%	0.0%	0.0%	0.0%	0.0%	0.0%	0.0%	0.0%	0.0%	0.0%	0.0%	0.0%	0.0%	0.0%	0.0%	0.0%	0.0%	0.0%	0.0%	0.0%	0.0%	0.0%	0.0%	0.0%	0.0%	0.0%	0.0%	0.0%	0.0%	0.0%	0.0%																
Bicycles on Crosswalk	0	0	0	0	0	0	0	0	0	0	0	0	0	0	0	0	0	0	0	0	0	0	0	0	0	0	0	0	0	0	0	0	0	0	0																
% Bicycles on Crosswalk	0.0%	0.0%	0.0%	0.0%	0.0%	0.0%	0.0%	0.0%	0.0%	0.0%	0.0%	0.0%	0.0%	0.0%	0.0%	0.0%	0.0%	0.0%	0.0%	0.0%	0.0%	0.0%	0.0%	0.0%	0.0%	0.0%	0.0%	0.0%	0.0%	0.0%	0.0%	0.0%	0.0%	0.0%	0.0%																

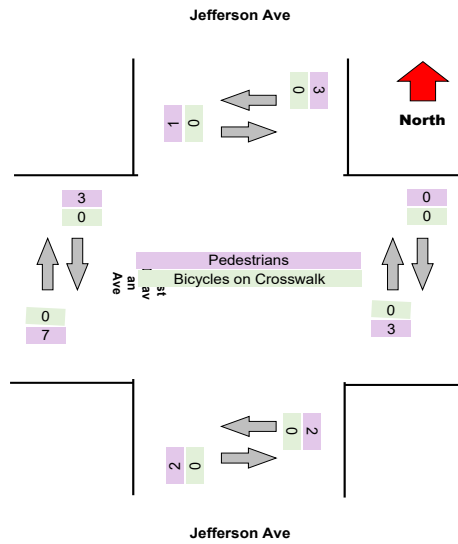
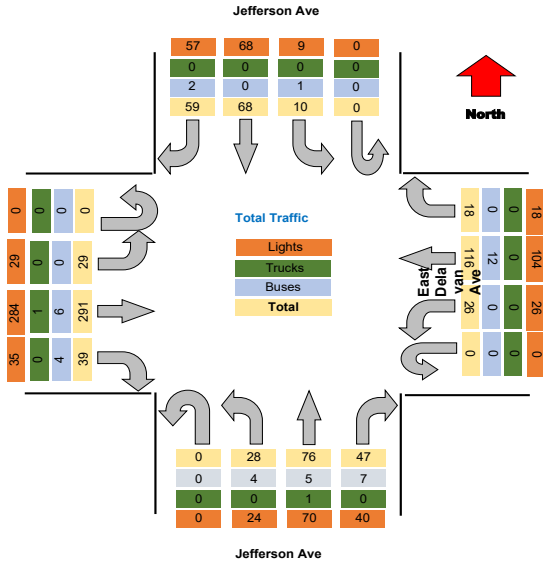

Turning Movement Peak Hour Data (PM)

4:30:00 PM

Leg Direction	Jefferson Ave				East Delavan Ave				Jefferson Ave				East Delavan Ave				Total													
	Southbound				Westbound				Northbound				Eastbound																	
	Right	Thru	Left	U-Turn	App Total	Peds CV	Peds CCW	Right	Thru	Left	U-Turn	App Total	Peds CV	Peds CCW	Right	Thru		Left	U-Turn	App Total	Peds CV	Peds CCW								
4:30:00 PM	7	29	2	0	38	1	4	7	34	7	0	48	0	1	20	34	6	0	60	0	1	20	76	16	0	112	4	1	258	
4:45:00 PM	6	19	4	0	29	1	0	6	32	10	0	48	2	1	15	28	4	0	47	1	0	16	53	21	0	90	0	2	214	
5:00:00 PM	10	29	5	0	44	4	3	5	34	10	0	49	4	1	15	32	13	0	60	2	2	17	68	21	0	106	0	1	259	
5:15:00 PM	8	27	5	0	40	1	0	9	31	11	0	51	1	4	13	27	12	0	52	1	2	10	62	17	0	89	2	2	232	
Grand Total	31	104	16	0	151	7	7	27	131	38	0	196	7	7	63	121	35	0	219	4	5	63	259	75	0	397	3	6	963	
% Approach	20.5%	68.9%	10.6%	0.0%	0.0%	0.0%	0.0%	13.8%	66.8%	19.4%	0.0%	0.0%	0.0%	0.0%	28.6%	55.3%	16.0%	0.0%	0.0%	0.0%	0.0%	15.9%	65.2%	18.9%	0.0%	0.0%	0.0%	0.0%	0.0%	
% Total	3.2%	10.8%	1.7%	0.0%	15.7%	0.0%	0.0%	2.8%	13.6%	3.9%	0.0%	20.4%	0.0%	0.0%	6.5%	12.6%	3.6%	0.0%	22.7%	0.0%	0.0%	6.5%	26.9%	7.8%	0.0%	41.2%	0.0%	0.0%	0.0%	
PHF	0.775	0.897	0.800	0.000	0.858	0.000	0.000	0.750	0.963	0.864	0.000	0.961	0.000	0.000	0.788	0.890	0.673	0.000	0.913	0.000	0.000	0.788	0.852	0.893	0.000	0.886	0.000	0.000	0.930	
Lights	31	101	16	0	148	0	0	27	124	38	0	189	0	0	60	118	33	0	211	0	0	61	252	74	0	387	0	0	935	
% Lights	100.0%	97.1%	100.0%	0.0%	98.0%	0.0%	0.0%	100.0%	94.7%	100.0%	0.0%	96.4%	0.0%	0.0%	85.2%	97.5%	94.3%	0.0%	96.3%	0.0%	0.0%	96.8%	97.3%	98.7%	0.0%	97.5%	0.0%	0.0%	97.1%	
Trucks	0	0	0	0	0	0	0	0	0	0	0	0	0	0	0	0	0	0	0	0	0	0	0	0	0	0	0	0	0	
% Trucks	0.0%	0.0%	0.0%	0.0%	0.0%	0.0%	0.0%	0.0%	0.0%	0.0%	0.0%	0.0%	0.0%	0.0%	0.0%	0.0%	0.0%	0.0%	0.0%	0.0%	0.0%	0.0%	0.0%	0.0%	0.0%	0.0%	0.0%	0.0%	0.0%	
Buses	0	3	0	0	3	0	0	0	7	0	0	7	0	0	3	3	2	0	8	0	0	2	7	1	0	10	0	0	28	
% Buses	0.0%	2.9%	0.0%	0.0%	0.0%	0.0%	0.0%	0.0%	5.3%	0.0%	0.0%	0.0%	0.0%	0.0%	4.8%	2.5%	5.7%	0.0%	0.0%	0.0%	0.0%	3.2%	2.7%	1.3%	0.0%	0.0%	0.0%	0.0%	2.9%	
Pedestrians	0	0	0	0	0	7	7	0	0	0	0	7	7	0	0	0	0	0	0	4	5	0	0	0	0	0	6	6	0	
% Pedestrians	0.0%	0.0%	0.0%	0.0%	0.0%	100.0%	100.0%	0.0%	0.0%	0.0%	0.0%	0.0%	100.0%	100.0%	0.0%	0.0%	0.0%	0.0%	0.0%	0.0%	100.0%	100.0%	0.0%	0.0%	0.0%	0.0%	0.0%	0.0%	100.0%	0.0%
Bicycles on Crosswalk	0	0	0	0	0	0	0	0	0	0	0	0	0	0	0	0	0	0	0	0	0	0	0	0	0	0	0	0	0	
% Bicycles on Crosswalk	0.0%	0.0%	0.0%	0.0%	0.0%	0.0%	0.0%	0.0%	0.0%	0.0%	0.0%	0.0%	0.0%	0.0%	0.0%	0.0%	0.0%	0.0%	0.0%	0.0%	0.0%	0.0%	0.0%	0.0%	0.0%	0.0%	0.0%	0.0%	0.0%	

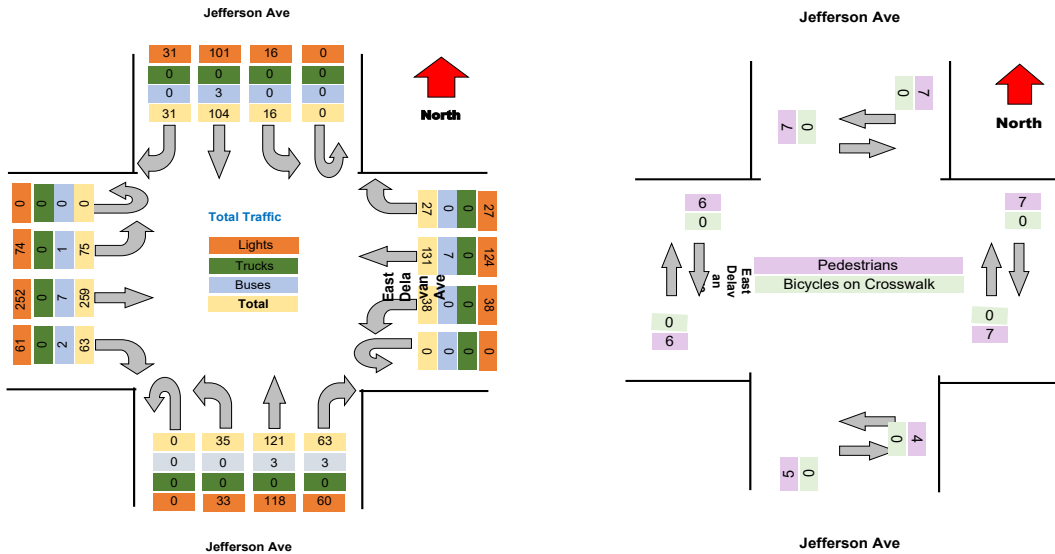

Project : VBH Malta NY
 Site : Site 4
 Location : 42.948550, -73.790036

TSTData.com

Survey Date : 2021-04-28, Wednesday

Project	LaBella
Project Code	LaBella
Site Name	30
Legs and Movements	All Processed Legs & Move
Bin Size	15 minutes
Survey Date	2021-11-02, Tuesday
Location	30
Latitude and Longitude	42.919362, -78.853974

	Start	End	PHF
Forced Peak AM	2021/11/02 07:30:00	2021/11/02 08:30:00	0.9
Forced Peak PM	2021/11/02 16:30:00	2021/11/02 17:30:00	0.94
AM Peak	2021/11/02 07:30:00	2021/11/02 08:30:00	0.9
PM Peak	2021/11/02 17:00:00	2021/11/02 18:00:00	0.85

Turning Movement Data

Leg Direction	Jefferson Ave								Northland Ave								Jefferson Ave								Northland Ave								Total
	Southbound				Westbound				Northbound				Eastbound				Southbound				Westbound				Northbound				Eastbound				
	Right	Thru	Left	U-Turn	App Total	Peds CW	Peds CCW		Right	Thru	Left	U-Turn	App Total	Peds CW	Peds CCW		Right	Thru	Left	U-Turn	App Total	Peds CW	Peds CCW		Right	Thru	Left	U-Turn	App Total	Peds CW	Peds CCW		
6:30:00 AM	1	10	0	0	11	0	0	0	1	2	0	3	0	0		2	15	0	0	17	0	0		1	1	0	0	2	1	0		33	
6:45:00 AM	0	11	1	0	12	0	0	1	1	1	0	3	0	0		4	13	0	0	17	0	0		0	0	1	0	1	0	0		33	
Hourly Total	1	21	1	0	23	0	0	1	2	3	0	6	0	0		6	28	0	0	34	0	0		1	1	1	0	3	1	0		66	
7:00:00 AM	1	9	2	0	12	0	0	3	0	2	0	5	0	0		2	41	2	0	45	0	0		1	0	1	0	2	0	1		64	
7:15:00 AM	1	14	1	0	16	0	0	3	1	2	0	6	0	0		3	23	0	0	26	0	0		2	1	2	0	5	0	0		53	
7:30:00 AM	2	14	1	0	17	0	0	1	1	1	0	3	0	0		1	24	0	0	24	0	0		1	2	1	0	4	0	0		48	
7:45:00 AM	1	23	4	0	28	0	0	1	2	0	0	3	0	0		1	26	1	0	28	0	0		1	2	0	0	3	0	0		62	
Hourly Total	5	60	8	0	73	0	0	8	4	5	0	17	0	0		6	114	3	0	123	0	0		5	5	4	0	14	0	1		227	
8:00:00 AM	1	20	3	0	24	1	0	1	4	1	0	6	0	0		3	20	0	0	23	0	0		3	1	2	0	6	0	0		59	
8:15:00 AM	1	28	0	0	29	0	0	2	0	2	0	4	0	0		0	15	0	0	15	0	0		2	2	2	0	6	0	0		54	
Hourly Total	2	48	3	0	53	1	0	3	4	3	0	10	0	0		3	35	0	0	38	0	0		5	3	4	0	12	0	0		113	
4:00:00 PM	4	46	5	0	55	0	0	5	8	5	0	18	0	0		7	43	4	0	54	4	4		3	3	7	0	13	4	1		140	
4:15:00 PM	4	44	11	0	59	0	0	2	4	7	0	13	0	0		7	44	3	0	54	2	2		3	3	6	0	12	5	2		138	
4:30:00 PM	4	51	7	0	62	0	0	4	5	6	0	17	1	0		7	48	3	0	58	4	3		2	2	1	0	5	4	3		142	
4:45:00 PM	4	37	6	0	47	1	0	3	3	6	0	12	2	0		7	45	3	0	55	2	1		0	3	3	0	6	5	4		120	
Hourly Total	16	178	29	0	223	1	0	14	20	26	0	60	3	0		28	190	13	0	221	12	10		8	11	17	0	36	19	10		540	
5:00:00 PM	5	42	4	1	52	1	0	2	3	3	0	8	0	0		13	40	5	0	59	3	1		4	7	4	0	15	3	2		133	
5:15:00 PM	5	42	7	0	54	0	0	4	10	0	14	1	1		4	49	4	0	57	3	2		5	5	5	0	15	4	4		140		
5:30:00 PM	2	30	4	0	36	0	0	1	5	2	0	8	0	1		7	43	2	0	52	1	3		0	2	3	0	5	6	1		101	
5:45:00 PM	4	32	9	0	45	0	0	2	2	3	0	7	0	0		1	41	3	0	45	2	2		0	7	0	0	7	5	6		104	
Hourly Total	16	146	24	1	187	1	0	9	20	8	0	37	1	4		25	173	14	0	212	9	8		9	21	12	0	42	18	13		478	
Grand Total	40	453	65	1	559	3	0	35	50	45	0	130	4	4		68	530	30	0	628	21	18		28	41	38	0	107	38	24		1424	
% Approach	7.2%	81.0%	11.6%	0.2%	0.0%	0.0%	0.0%	26.9%	38.5%	34.6%	0.0%	0.0%	0.0%	0.0%		10.8%	84.4%	4.8%	0.0%	0.0%	0.0%	0.0%		26.2%	38.3%	35.5%	0.0%	0.0%	0.0%	0.0%		0.0%	
% Total	2.8%	31.8%	4.6%	0.1%	39.3%	0.0%	0.0%	2.5%	3.5%	3.2%	0.0%	8.1%	0.0%	0.0%		4.8%	37.2%	2.1%	0.0%	44.1%	0.0%	0.0%		2.0%	2.9%	2.7%	0.0%	7.5%	0.0%	0.0%		0.0%	
Lights	40	443	64	1	548	0	0	33	50	43	0	126	0	0		67	520	30	0	617	0	0		27	40	35	0	102	0	0		1393	
% Lights	100.0%	97.8%	98.5%	100.0%	98.0%	0.0%	0.0%	94.3%	100.0%	95.6%	0.0%	98.9%	0.0%	0.0%		98.5%	98.1%	100.0%	0.0%	98.2%	0.0%	0.0%		96.4%	97.6%	92.1%	0.0%	95.3%	0.0%	0.0%		97.8%	
Trucks	0	0	0	0	0	0	0	0	0	0	0	0	0	0		0	0	0	0	0	0	0		0	0	0	0	0	0	0		0	
% Trucks	0.0%	0.0%	0.0%	0.0%	0.0%	0.0%	0.0%	0.0%	0.0%	0.0%	0.0%	0.0%	0.0%	0.0%		0.0%	0.0%	0.0%	0.0%	0.0%	0.0%	0.0%		0.0%	0.0%	0.0%	0.0%	0.0%	0.0%	0.0%		0.0%	
Buses	0	9	1	0	10	0	0	2	0	2	0	4	0	0		1	10	0	0	11	0	0		1	1	3	0	5	0	0		30	
% Buses	0.0%	2.0%	1.5%	0.0%	0.0%	0.0%	0.0%	0.0%	0.0%	4.4%	0.0%	0.0%	0.0%	0.0%		1.5%	1.9%	0.0%	0.0%	0.0%	0.0%	0.0%		3.6%	2.4%	7.9%	0.0%	0.0%	0.0%	0.0%		2.1%	
Pedestrians	0	0	0	0	0	3	0	0	0	0	0	0	4	4		0	0	0	0	0	21	16		0	0	0	0	0	34	23		0	
% Pedestrians	0.0%	0.0%	0.0%	0.0%	0.0%	100.0%	0.0%	0.0%	0.0%	0.0%	0.0%	0.0%	100.0%	100.0%		0.0%	0.0%	0.0%	0.0%	0.0%	100.0%	100.0%		0.0%	0.0%	0.0%	0.0%	0.0%	89.6%	85.8%		0.0%	
Bicycles on Crosswalk	0	0	0	0	0	0	0	0	0	0	0	0	0	0		0	0	0	0	0	0	0		0	0	0	0	0	4	1		0	
% Bicycles on Crosswalk	0.0%	0.0%	0.0%	0.0%	0.0%	0.0%	0.0%	0.0%	0.0%	0.0%	0.0%	0.0%	0.0%	0.0%		0.0%	0.0%	0.0%	0.0%	0.0%	0.0%	0.0%		0.0%	0.0%	0.0%	0.0%	0.0%	10.5%	4.2%		0.0%	

Project : VBH Malta NY
 Site : Site 4
 Location : 42.948550, -73.790036
 Survey Date : 2021-04-28, Wednesday

Turning Movement Data Plot

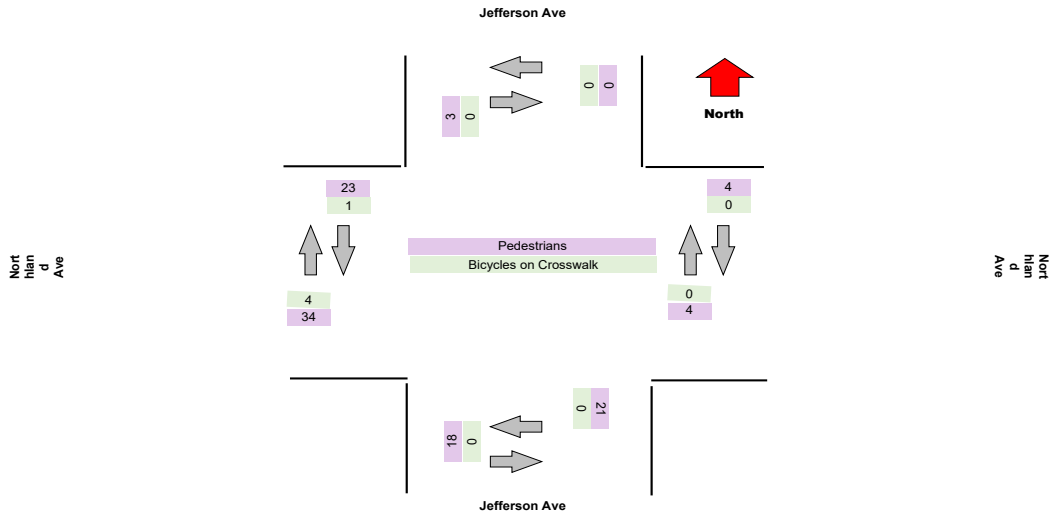
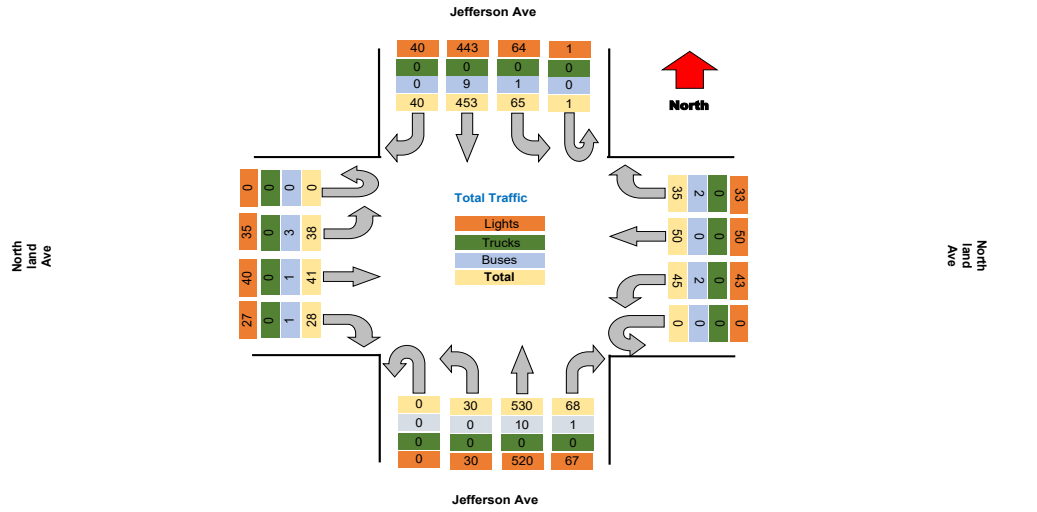

Project : VBH Malta NY
Site : Site 4
Location : 42.948550, -73.790036

TSTData.com

Survey Date : 2021-04-28, Wednesday

Turning Movement Peak Hour Data (AM)

7:30:00 AM

Leg Direction	Jefferson Ave					Northland Ave					Jefferson Ave					Northland Ave					Total								
	Right	Thru	Left	U-Turn	App Total	Peds CW	Peds CCW	Right	Thru	Left	U-Turn	App Total	Peds CW	Peds CCW	Right	Thru	Left	U-Turn	App Total	Peds CW		Peds CCW							
7:30:00 AM	2	14	1	0	17	0	0	1	1	1	0	3	0	0	0	24	0	0	24	0	0	48							
7:45:00 AM	1	23	4	0	28	0	0	1	2	0	0	3	0	0	1	26	1	0	28	0	0	62							
8:00:00 AM	1	20	3	0	24	1	0	1	4	1	0	6	0	0	3	20	0	0	23	0	0	59							
8:15:00 AM	1	28	0	0	29	0	0	2	0	2	0	4	0	0	0	15	0	0	15	0	0	54							
Grand Total	5	85	8	0	98	1	0	5	7	4	0	16	0	0	4	85	1	0	89	0	0	223							
% Approach	5.1%	86.7%	8.2%	0.0%	0.0%	0.0%	0.0%	31.3%	43.8%	25.0%	0.0%	0.0%	0.0%	0.0%	4.4%	94.4%	1.1%	0.0%	0.0%	0.0%	0.0%	36.8%	36.8%	26.3%	0.0%	0.0%	0.0%		
% Total	2.2%	38.1%	3.6%	0.0%	43.8%	0.0%	0.0%	2.2%	3.1%	1.8%	0.0%	7.2%	0.0%	0.0%	1.8%	38.1%	0.4%	0.0%	40.4%	0.0%	0.0%	3.1%	3.1%	2.2%	0.0%	8.5%	0.0%	0.0%	
PHF	0.625	0.759	0.500	0.000	0.845	0.000	0.000	0.625	0.438	0.500	0.000	0.667	0.000	0.000	0.333	0.817	0.250	0.000	0.804	0.000	0.000	0.583	0.875	0.625	0.000	0.792	0.000	0.000	
Lights	5	83	8	0	96	0	0	5	7	4	0	16	0	0	4	82	1	0	87	0	0	7	7	5	0	19	0	0	
% Lights	100.0%	97.6%	100.0%	0.0%	98.0%	0.0%	0.0%	100.0%	100.0%	100.0%	0.0%	100.0%	0.0%	0.0%	100.0%	96.5%	100.0%	0.0%	96.7%	0.0%	0.0%	100.0%	100.0%	100.0%	0.0%	100.0%	0.0%	0.0%	
Trucks	0	0	0	0	0	0	0	0	0	0	0	0	0	0	0	0	0	0	0	0	0	0	0	0	0	0	0	0	0
% Trucks	0.0%	0.0%	0.0%	0.0%	0.0%	0.0%	0.0%	0.0%	0.0%	0.0%	0.0%	0.0%	0.0%	0.0%	0.0%	0.0%	0.0%	0.0%	0.0%	0.0%	0.0%	0.0%	0.0%	0.0%	0.0%	0.0%	0.0%	0.0%	0.0%
Buses	0	2	0	0	2	0	0	0	0	0	0	0	0	0	0	3	0	0	3	0	0	0	0	0	0	0	0	0	5
% Buses	0.0%	2.4%	0.0%	0.0%	0.0%	0.0%	0.0%	0.0%	0.0%	0.0%	0.0%	0.0%	0.0%	0.0%	0.0%	3.5%	0.0%	0.0%	0.0%	0.0%	0.0%	0.0%	0.0%	0.0%	0.0%	0.0%	0.0%	0.0%	2.2%
Pedestrians	0	0	0	0	0	1	0	0	0	0	0	0	0	0	0	0	0	0	0	0	0	0	0	0	0	0	0	0	0
% Pedestrians	0.0%	0.0%	0.0%	0.0%	0.0%	100.0%	0.0%	0.0%	0.0%	0.0%	0.0%	0.0%	0.0%	0.0%	0.0%	0.0%	0.0%	0.0%	0.0%	0.0%	0.0%	0.0%	0.0%	0.0%	0.0%	0.0%	0.0%	0.0%	0.0%
Bicycles on Crosswalk	0	0	0	0	0	0	0	0	0	0	0	0	0	0	0	0	0	0	0	0	0	0	0	0	0	0	0	0	0
% Bicycles on Crosswalk	0.0%	0.0%	0.0%	0.0%	0.0%	0.0%	0.0%	0.0%	0.0%	0.0%	0.0%	0.0%	0.0%	0.0%	0.0%	0.0%	0.0%	0.0%	0.0%	0.0%	0.0%	0.0%	0.0%	0.0%	0.0%	0.0%	0.0%	0.0%	0.0%

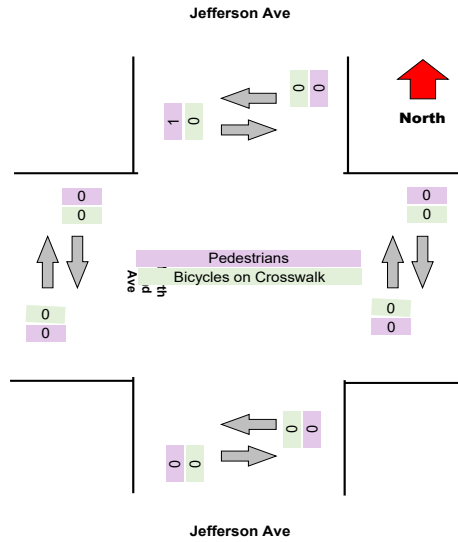
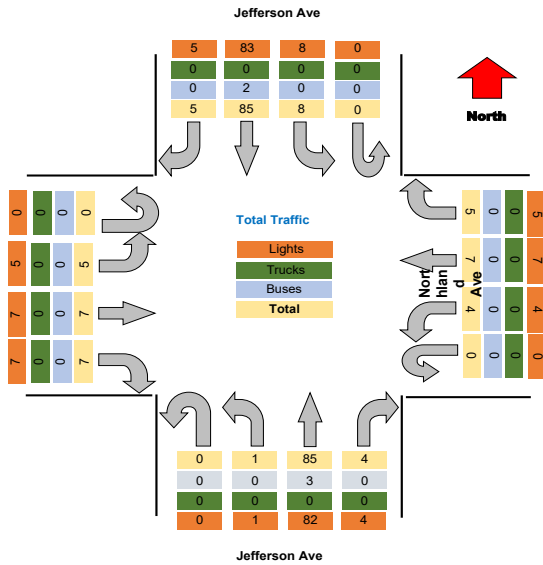

Turning Movement Peak Hour Data (PM)

5:00:00 PM

Leg Direction	Jefferson Ave										Northland Ave										Total									
	Southbound					Westbound					Northbound					Eastbound														
	Right	Thru	Left	U-Turn	App Total	Peds CW	Peds CCW	Right	Thru	Left	U-Turn	App Total	Peds CW	Peds CCW	Right	Thru	Left	U-Turn	App Total	Peds CW		Peds CCW								
5:00:00 PM	5	42	4	1	52	1	0	2	3	3	0	8	0	2	13	40	5	0	58	3	1	4	7	4	0	15	3	2	133	
5:15:00 PM	5	42	7	0	54	0	0	4	10	0	0	14	1	1	4	49	4	0	57	3	2	5	5	5	0	15	4	4	140	
5:30:00 PM	2	30	4	0	36	0	0	1	5	2	0	8	0	1	7	43	2	0	52	1	3	0	2	3	0	5	6	1	101	
5:45:00 PM	4	32	9	0	45	0	0	2	2	3	0	7	0	0	1	41	3	0	45	2	2	0	7	0	0	7	5	6	104	
Grand Total	16	146	24	1	187	1	0	9	20	6	0	37	1	4	25	173	14	0	212	3	6	9	21	12	0	42	15	13	478	
% Approach	8.6%	78.1%	12.8%	0.5%	0.0%	0.0%	0.0%	24.3%	54.1%	21.6%	0.0%	0.0%	0.0%	0.0%	11.8%	81.6%	6.6%	0.0%	0.0%	0.0%	0.0%	21.4%	50.0%	28.6%	0.0%	0.0%	0.0%	0.0%	0.0%	
% Total	3.3%	30.5%	5.0%	0.2%	38.1%	0.0%	0.0%	1.9%	4.2%	1.7%	0.0%	7.7%	0.0%	0.0%	5.2%	36.2%	2.9%	0.0%	44.4%	0.0%	0.0%	1.9%	4.4%	2.5%	0.0%	8.8%	0.0%	0.0%	0.0%	
PHF	0.800	0.869	0.667	0.250	0.866	0.000	0.000	0.563	0.500	0.667	0.000	0.661	0.000	0.000	0.481	0.883	0.700	0.000	0.814	0.000	0.000	0.450	0.750	0.600	0.000	0.700	0.000	0.000	0.854	
Lights	16	144	24	1	185	0	0	9	20	6	0	37	0	0	25	171	14	0	210	0	0	9	21	12	0	42	0	0	474	
% Lights	100.0%	98.6%	100.0%	100.0%	98.9%	0.0%	0.0%	100.0%	100.0%	100.0%	0.0%	100.0%	0.0%	0.0%	100.0%	98.8%	100.0%	0.0%	99.1%	0.0%	0.0%	100.0%	100.0%	100.0%	0.0%	100.0%	0.0%	0.0%	99.2%	
Trucks	0	0	0	0	0	0	0	0	0	0	0	0	0	0	0	0	0	0	0	0	0	0	0	0	0	0	0	0	0	
% Trucks	0.0%	0.0%	0.0%	0.0%	0.0%	0.0%	0.0%	0.0%	0.0%	0.0%	0.0%	0.0%	0.0%	0.0%	0.0%	0.0%	0.0%	0.0%	0.0%	0.0%	0.0%	0.0%	0.0%	0.0%	0.0%	0.0%	0.0%	0.0%	0.0%	
Buses	0	2	0	0	2	0	0	0	0	0	0	0	0	0	0	2	0	0	2	0	0	0	0	0	0	0	0	0	4	
% Buses	0.0%	1.4%	0.0%	0.0%	0.0%	0.0%	0.0%	0.0%	0.0%	0.0%	0.0%	0.0%	0.0%	0.0%	0.0%	1.2%	0.0%	0.0%	0.0%	0.0%	0.0%	0.0%	0.0%	0.0%	0.0%	0.0%	0.0%	0.0%	0.8%	
Pedestrians	0	0	0	0	0	1	0	0	0	0	1	4	0	4	0	0	0	0	9	8	0	0	0	0	0	0	0	18	12	0
% Pedestrians	0.0%	0.0%	0.0%	0.0%	0.0%	100.0%	0.0%	0.0%	0.0%	0.0%	0.0%	100.0%	100.0%	100.0%	0.0%	0.0%	0.0%	0.0%	0.0%	0.0%	0.0%	0.0%	0.0%	0.0%	0.0%	0.0%	0.0%	100.0%	92.3%	0.0%
Bicycles on Crosswalk	0	0	0	0	0	0	0	0	0	0	0	0	0	0	0	0	0	0	0	0	0	0	0	0	0	0	0	1	0	
% Bicycles on Crosswalk	0.0%	0.0%	0.0%	0.0%	0.0%	0.0%	0.0%	0.0%	0.0%	0.0%	0.0%	0.0%	0.0%	0.0%	0.0%	0.0%	0.0%	0.0%	0.0%	0.0%	0.0%	0.0%	0.0%	0.0%	0.0%	0.0%	0.0%	7.7%	0.0%	

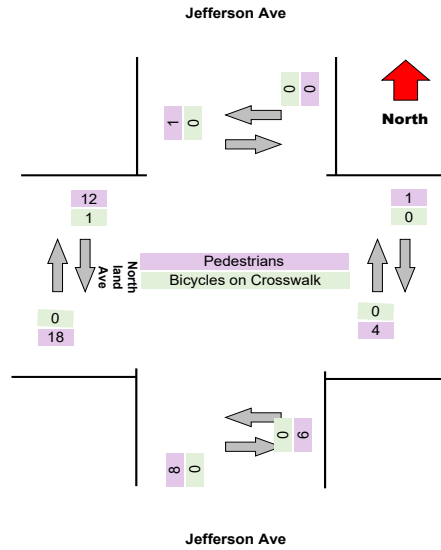
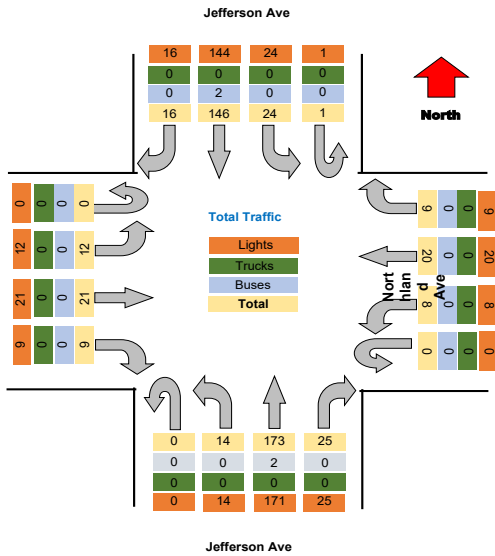

Project : VBH Malta NY
 Site : Site 4
 Location : 42.948550, -73.790036

TSTData.com

Survey Date : 2021-04-28, Wednesday

Project	LaBella
Project Code	LaBella
Site Name	30
Legs and Movements	All Processed Legs & Move
Bin Size	15 minutes
Survey Date	2021-11-03, Wednesday
Location	30
Latitude and Longitude	42.919362, -78.853974

	Start	End	PHF
Forced Peak AM	2021/11/03 07:30:00	2021/11/03 08:30:00	0.83
Forced Peak PM	2021/11/03 16:30:00	2021/11/03 17:30:00	0.84
AM Peak	2021/11/03 07:30:00	2021/11/03 08:30:00	0.83
PM Peak	2021/11/03 17:00:00	2021/11/03 18:00:00	0.91

Turning Movement Data

Leg Direction	Jefferson Ave										Northland Ave										Total									
	Southbound					Westbound					Northbound					Eastbound														
	Right	Thru	Left	U-Turn	App Total	Right	Thru	Left	U-Turn	App Total	Right	Thru	Left	U-Turn	App Total	Right	Thru	Left	U-Turn	App Total										
6:30:00 AM	3	11	0	0	14	0	0	2	0	2	0	15	0	0	16	1	2	0	0	3	35									
6:45:00 AM	1	17	1	0	19	0	1	2	0	3	2	16	2	0	20	2	1	0	0	3	47									
Hourly Total	4	28	1	0	33	0	1	4	0	5	2	31	2	0	35	3	3	0	0	6	82									
7:00:00 AM	0	21	1	0	22	3	0	3	0	6	1	32	1	0	34	2	2	1	0	5	67									
7:15:00 AM	4	15	2	0	21	1	2	1	0	4	1	28	1	0	30	1	3	4	0	8	64									
7:30:00 AM	4	18	3	0	25	1	0	3	0	4	2	31	1	0	34	1	4	1	0	6	69									
7:45:00 AM	4	48	1	0	53	7	2	5	0	15	0	23	5	0	28	5	2	5	0	12	109									
Hourly Total	12	102	7	0	121	12	4	12	0	29	2	4	114	8	128	9	11	11	0	31	4	309								
8:00:00 AM	3	29	6	0	38	0	1	1	0	2	3	37	3	0	43	1	7	3	0	11	96									
8:15:00 AM	2	25	0	0	27	5	2	4	0	11	0	2	35	1	38	2	7	4	0	13	89									
Hourly Total	5	54	6	0	65	5	3	5	0	13	1	5	72	4	83	3	14	7	0	24	2	185								
4:00:00 PM	4	47	2	0	53	7	3	3	0	13	0	0	56	3	63	4	6	4	0	14	5	147								
4:15:00 PM	1	54	6	0	61	4	6	4	0	14	1	0	7	54	63	5	8	7	0	16	4	157								
4:30:00 PM	5	62	9	0	76	4	8	5	0	17	0	0	4	46	56	2	10	7	0	22	4	171								
4:45:00 PM	2	36	2	0	40	6	1	3	0	10	1	1	4	47	55	2	3	7	0	16	4	121								
Hourly Total	12	199	19	0	230	21	18	15	0	54	2	1	23	203	244	10	18	28	22	68	17	596								
5:00:00 PM	5	40	4	0	49	5	6	3	0	14	0	0	4	51	60	1	2	11	11	24	3	147								
5:15:00 PM	3	39	4	0	46	2	2	2	0	6	0	0	7	51	65	5	8	6	4	18	4	135								
5:30:00 PM	2	45	5	0	52	6	3	3	0	12	1	0	14	43	62	2	4	4	4	12	1	138								
5:45:00 PM	2	38	5	0	45	4	4	3	0	11	0	0	2	43	50	2	2	4	6	12	2	118								
Hourly Total	12	162	18	0	192	17	15	11	0	43	1	0	27	188	220	10	16	25	25	66	10	538								
Grand Total	45	545	51	0	641	55	41	47	0	145	4	6	61	608	80	4	49	81	65	195	33	1710								
% Approach	7.0%	85.0%	8.0%	0.0%	0.0%	37.9%	28.3%	32.4%	0.0%	0.0%	0.0%	0.0%	8.4%	83.4%	6.9%	0.5%	0.0%	0.0%	0.0%	0.0%	25.1%	41.5%	33.3%	0.0%	0.0%	0.0%	0.0%	0.0%	0.0%	0.0%
% Total	2.6%	31.9%	3.0%	0.0%	37.5%	3.2%	2.4%	2.7%	0.0%	8.5%	0.0%	0.0%	3.6%	35.6%	2.9%	0.2%	42.6%	0.0%	0.0%	0.0%	2.9%	4.7%	3.8%	0.0%	11.4%	0.0%	0.0%	0.0%	0.0%	0.0%
Lights	44	522	46	0	612	49	39	40	0	128	0	0	60	574	45	4	45	72	58	175	0	1598								
% Lights	97.8%	95.6%	90.2%	0.0%	95.2%	89.1%	95.1%	85.1%	0.0%	88.3%	0.0%	0.0%	88.4%	84.4%	90.0%	100.0%	93.7%	0.0%	0.0%	99.7%	0.0%	0.0%	0.0%	0.0%	99.7%	0.0%	0.0%	0.0%	0.0%	99.7%
Trucks	0	1	0	0	1	0	0	0	0	0	0	0	0	1	0	0	0	0	0	0	0	0	0	0	0	0	0	0	0	0
% Trucks	0.0%	0.2%	0.0%	0.0%	0.2%	0.0%	0.0%	0.0%	0.0%	0.0%	0.0%	0.0%	0.0%	0.2%	0.0%	0.1%	0.0%	0.0%	0.0%	0.0%	0.0%	0.0%	0.0%	0.0%	0.0%	0.0%	0.0%	0.0%	0.0%	0.1%
Buses	1	22	5	0	28	6	2	7	0	15	0	0	1	33	5	0	39	0	0	20	0	102								
% Buses	2.2%	4.0%	9.8%	0.0%	0.0%	0.0%	4.9%	14.9%	0.0%	0.0%	0.0%	0.0%	1.6%	5.4%	10.0%	0.0%	0.0%	0.0%	0.0%	0.0%	8.2%	11.1%	10.8%	0.0%	0.0%	0.0%	0.0%	0.0%	0.0%	6.0%
Pedestrians	0	0	0	0	0	0	0	0	0	0	4	6	0	0	0	20	21	0	0	0	32	33	0	0	0					
% Pedestrians	0.0%	0.0%	0.0%	0.0%	0.0%	0.0%	0.0%	0.0%	0.0%	0.0%	100.0%	100.0%	0.0%	0.0%	0.0%	0.0%	100.0%	100.0%	0.0%	0.0%	0.0%	0.0%	0.0%	0.0%	0.0%	0.0%	97.0%	94.3%	0.0%	0.0%
Bicycles on Crosswalk	0	0	0	0	0	0	0	0	0	0	0	0	0	0	0	0	0	0	0	0	1	2	0	0	0					
% Bicycles on Crosswalk	0.0%	0.0%	0.0%	0.0%	0.0%	0.0%	0.0%	0.0%	0.0%	0.0%	0.0%	0.0%	0.0%	0.0%	0.0%	0.0%	0.0%	0.0%	0.0%	0.0%	0.0%	0.0%	0.0%	0.0%	0.0%	0.0%	3.0%	5.7%	0.0%	0.0%

Project : VBH Malta NY
 Site : Site 4
 Location : 42.948550, -73.790036
 Survey Date : 2021-04-28, Wednesday

Turning Movement Data Plot

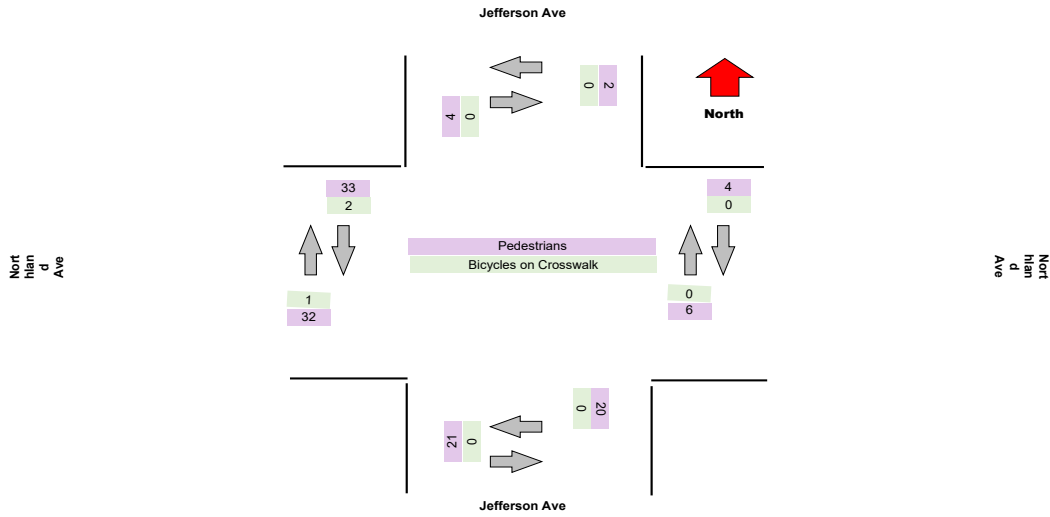
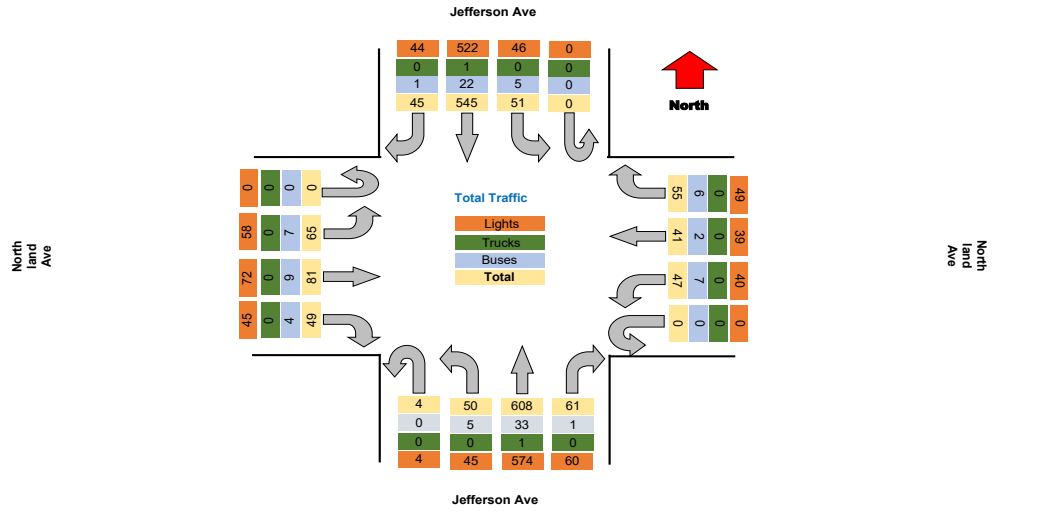

Turning Movement Peak Hour Data (AM)

7:30:00 AM

Leg Direction	Jefferson Ave				Northland Ave				Jefferson Ave				Northland Ave				Total
	Right	Thru	Left	U-Turn	Right	Thru	Left	U-Turn	Right	Thru	Left	U-Turn	Right	Thru	Left	U-Turn	
7:30:00 AM	4	18	3	0	1	0	3	0	2	31	1	0	1	4	1	0	69
7:45:00 AM	4	48	1	0	7	2	5	0	0	23	5	0	5	2	5	0	109
8:00:00 AM	3	29	6	0	0	1	1	0	3	37	3	0	1	7	3	0	96
8:15:00 AM	2	25	0	0	5	2	4	0	2	35	1	0	2	7	4	0	89
Grand Total	13	129	10	0	13	5	13	0	7	126	10	0	9	20	13	0	383
% Approach	9.1%	83.9%	7.0%	0.0%	40.6%	15.6%	40.6%	0.0%	4.8%	96.3%	6.8%	0.0%	21.4%	47.6%	31.0%	0.0%	
% Total	3.6%	33.1%	2.8%	0.0%	3.6%	1.4%	3.6%	0.0%	1.9%	34.7%	2.8%	0.0%	2.5%	5.5%	3.6%	0.0%	
PHF	0.813	0.625	0.417	0.000	0.464	0.625	0.650	0.000	0.583	0.851	0.500	0.000	0.450	0.714	0.650	0.000	
Lights	13	114	8	0	12	5	12	0	7	115	8	0	8	18	12	0	
% Lights	100.0%	88.0%	80.0%	0.0%	92.3%	100.0%	92.3%	0.0%	100.0%	91.3%	80.0%	0.0%	88.9%	90.0%	92.3%	0.0%	
Trucks	0	0	0	0	0	0	0	0	0	0	0	0	0	0	0	0	
% Trucks	0.0%	0.0%	0.0%	0.0%	0.0%	0.0%	0.0%	0.0%	0.0%	0.0%	0.0%	0.0%	0.0%	0.0%	0.0%	0.0%	
Buses	0	6	2	0	1	0	1	0	0	11	2	0	1	2	1	0	
% Buses	0.0%	5.0%	20.0%	0.0%	7.7%	0.0%	7.7%	0.0%	0.0%	8.7%	20.0%	0.0%	11.1%	10.0%	7.7%	0.0%	
Pedestrians	0	0	0	0	0	0	0	0	0	0	0	0	0	0	0	0	
% Pedestrians	0.0%	0.0%	0.0%	0.0%	0.0%	0.0%	0.0%	0.0%	0.0%	0.0%	0.0%	0.0%	0.0%	0.0%	0.0%	0.0%	
Bicycles on Crosswalk	0	0	0	0	0	0	0	0	0	0	0	0	0	0	0	0	
% Bicycles on Crosswalk	0.0%	0.0%	0.0%	0.0%	0.0%	0.0%	0.0%	0.0%	0.0%	0.0%	0.0%	0.0%	0.0%	0.0%	0.0%	0.0%	

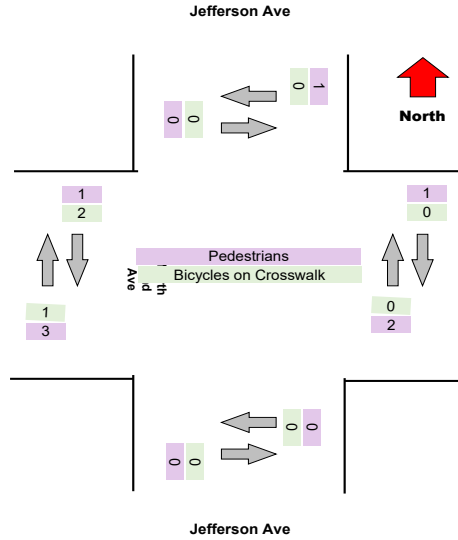
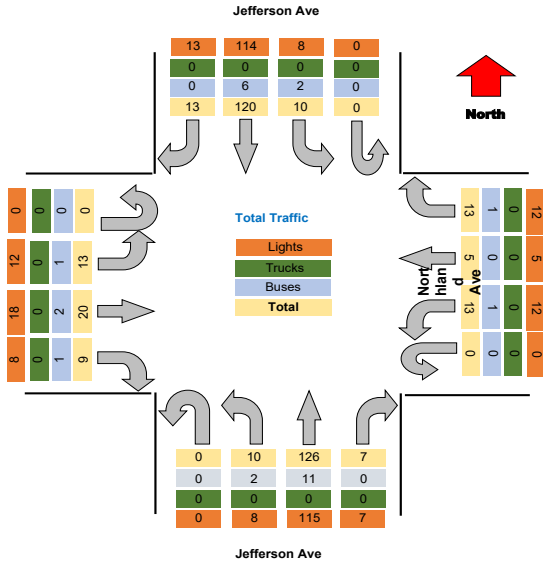

Turning Movement Peak Hour Data (PM)

5:00:00 PM

Leg Direction	Jefferson Ave										Northland Ave										Jefferson Ave										Northland Ave										Total
	Southbound					Westbound					Northbound					Eastbound																									
	Right	Thru	Left	U-Turn	App Total	Peds CW	Peds CCW	Right	Thru	Left	U-Turn	App Total	Peds CW	Peds CCW	Right	Thru	Left	U-Turn	App Total	Peds CW	Peds CCW	Right	Thru	Left	U-Turn	App Total	Peds CW	Peds CCW													
5:00:00 PM	5	40	4	0	49	0	0	5	6	3	0	14	0	0	4	51	5	0	60	1	2	2	11	11	0	24	3	3	147												
5:15:00 PM	3	39	4	0	46	3	0	2	2	2	0	6	0	0	7	51	7	0	65	5	4	8	6	4	0	18	4	4	136												
5:30:00 PM	2	45	5	0	52	0	0	6	3	3	0	12	1	0	14	43	5	0	62	2	2	4	4	4	0	12	1	6	138												
5:45:00 PM	2	39	5	0	45	0	0	4	4	3	0	11	0	0	2	43	5	0	50	2	2	2	4	6	0	12	2	3	118												
Grand Total	12	162	18	0	192	3	0	17	15	11	0	43	1	0	27	188	22	0	237	10	10	16	25	25	0	66	15	16	538												
% Approach	6.3%	84.4%	9.4%	0.0%	0.0%	0.0%	0.0%	39.5%	34.9%	25.6%	0.0%	0.0%	0.0%	0.0%	11.4%	79.3%	9.3%	0.0%	0.0%	0.0%	0.0%	24.2%	37.9%	37.9%	0.0%	0.0%	0.0%	0.0%	0.0%												
% Total	2.2%	30.1%	3.3%	0.0%	35.7%	0.0%	0.0%	3.2%	2.8%	2.0%	0.0%	8.0%	0.0%	0.0%	5.0%	34.9%	4.1%	0.0%	44.1%	0.0%	0.0%	3.0%	4.6%	4.6%	0.0%	12.3%	0.0%	0.0%	0.0%												
PHF	0.600	0.900	0.900	0.000	0.923	0.000	0.000	0.708	0.625	0.917	0.000	0.768	0.000	0.000	0.482	0.922	0.786	0.000	0.912	0.000	0.000	0.500	0.568	0.568	0.000	0.688	0.000	0.000	0.915												
Lights	12	158	17	0	187	0	0	16	15	11	0	42	0	0	27	180	22	0	229	0	0	16	25	23	0	64	0	0	522												
% Lights	100.0%	97.5%	94.4%	0.0%	97.4%	0.0%	0.0%	84.1%	100.0%	100.0%	0.0%	97.7%	0.0%	0.0%	100.0%	95.7%	100.0%	0.0%	96.6%	0.0%	0.0%	100.0%	100.0%	92.0%	0.0%	97.0%	0.0%	0.0%	97.0%												
Trucks	0	0	0	0	0	0	0	0	0	0	0	0	0	0	1	0	0	1	0	0	0	0	0	0	0	0	0	0	1												
% Trucks	0.0%	0.0%	0.0%	0.0%	0.0%	0.0%	0.0%	0.0%	0.0%	0.0%	0.0%	0.0%	0.0%	0.0%	0.0%	0.5%	0.0%	0.0%	0.4%	0.0%	0.0%	0.0%	0.0%	0.0%	0.0%	0.0%	0.0%	0.0%	0.2%												
Buses	0	4	1	0	5	0	0	1	0	0	0	1	0	0	7	0	0	7	0	0	0	0	0	2	0	2	0	0	15												
% Buses	0.0%	2.5%	5.6%	0.0%	0.0%	0.0%	0.0%	5.9%	0.0%	0.0%	0.0%	0.0%	0.0%	0.0%	0.0%	3.7%	0.0%	0.0%	0.0%	0.0%	0.0%	0.0%	0.0%	8.0%	0.0%	0.0%	0.0%	2.8%													
Pedestrians	0	0	0	0	0	3	0	0	0	0	0	0	1	0	0	0	0	0	0	10	10	0	0	0	0	0	10	16	0												
% Pedestrians	0.0%	0.0%	0.0%	0.0%	0.0%	100.0%	0.0%	0.0%	0.0%	0.0%	0.0%	0.0%	100.0%	0.0%	0.0%	0.0%	0.0%	0.0%	0.0%	100.0%	100.0%	0.0%	0.0%	0.0%	0.0%	0.0%	100.0%	100.0%	0.0%												
Bicycles on Crosswalk	0	0	0	0	0	0	0	0	0	0	0	0	0	0	0	0	0	0	0	0	0	0	0	0	0	0	0	0	0												
% Bicycles on Crosswalk	0.0%	0.0%	0.0%	0.0%	0.0%	0.0%	0.0%	0.0%	0.0%	0.0%	0.0%	0.0%	0.0%	0.0%	0.0%	0.0%	0.0%	0.0%	0.0%	0.0%	0.0%	0.0%	0.0%	0.0%	0.0%	0.0%	0.0%	0.0%	0.0%												

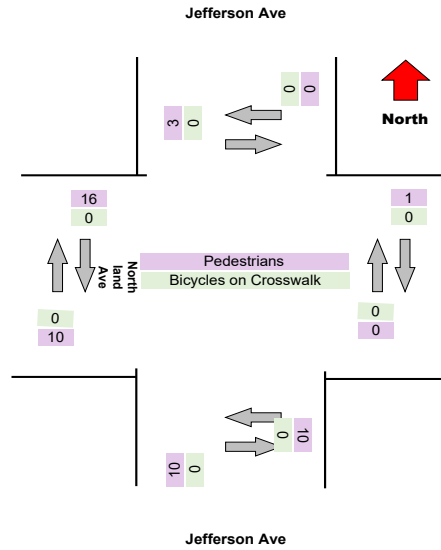
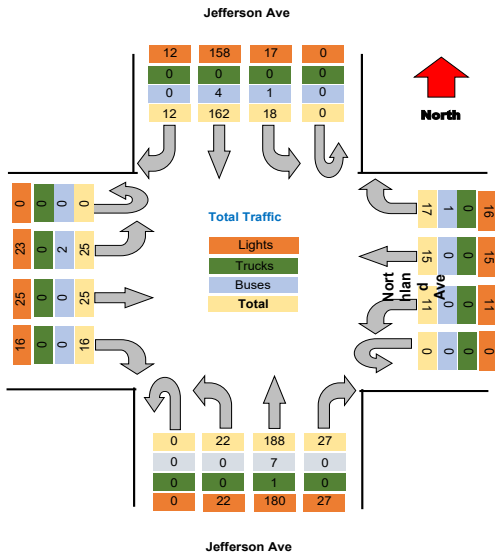

Project : VBH Malta NY
Site : Site 4
Location : 42.948550, -73.790036

TSTData.com

Survey Date : 2021-04-28, Wednesday

Project	LaBella
Project Code	LaBella
Site Name	30
Legs and Movements	All Processed Legs & Move
Bin Size	15 minutes
Survey Date	2021-11-04, Thursday
Location	30
Latitude and Longitude	42.919362, -78.853974

	Start	End	PHF
Forced Peak AM	2021/11/04 07:30:00	2021/11/04 08:30:00	0.9
Forced Peak PM	2021/11/04 16:30:00	2021/11/04 17:30:00	0.88
AM Peak	2021/11/04 07:30:00	2021/11/04 08:30:00	0.9
PM Peak	2021/11/04 17:00:00	2021/11/04 18:00:00	0.8

Turning Movement Data

Leg Direction	Jefferson Ave										Northland Ave										Jefferson Ave										Northland Ave										Total
	Southbound					Westbound					Northbound					Eastbound					Southbound					Westbound					Northbound					Eastbound					
	Right	Thru	Left	U-Turn	App Total	Peds CV	Peds CCV	Right	Thru	Left	U-Turn	App Total	Peds CV	Peds CCV	Right	Thru	Left	U-Turn	App Total	Peds CV	Peds CCV	Right	Thru	Left	U-Turn	App Total	Peds CV	Peds CCV	Right	Thru	Left	U-Turn	App Total	Peds CV	Peds CCV						
6:30:00 AM	1	14	0	0	15	0	0	1	0	0	0	1	0	0	2	13	1	0	16	0	0	1	3	1	0	5	0	0	1	3	1	0	5	0	0	37					
6:45:00 AM	3	9	1	0	13	0	0	0	1	2	0	3	0	1	1	19	0	0	21	0	0	1	0	3	0	4	1	0	1	0	3	0	4	1	0	41					
Hourly Total	4	23	1	0	28	0	0	1	1	2	0	4	0	1	3	32	1	0	37	0	0	2	3	4	0	9	1	1	2	3	4	0	9	1	1	78					
7:00:00 AM	1	8	1	0	10	0	0	4	2	2	0	8	0	1	1	19	1	0	22	0	0	0	2	1	0	3	3	2	0	2	1	0	3	3	2	43					
7:15:00 AM	4	17	0	0	21	0	0	1	1	2	0	4	0	0	1	29	1	0	31	0	0	0	3	3	0	6	1	0	0	3	3	0	6	1	0	62					
7:30:00 AM	5	31	2	0	38	0	0	1	0	1	0	2	0	0	2	30	4	0	36	0	0	0	2	3	3	8	0	0	0	2	3	3	8	0	0	84					
7:45:00 AM	6	25	2	0	33	0	1	7	4	2	0	14	0	0	4	30	1	0	35	0	0	0	2	2	5	9	0	0	0	2	2	5	9	0	0	91					
Hourly Total	16	81	5	0	102	0	1	13	7	7	0	28	0	1	8	108	7	0	124	0	0	0	7	10	9	26	4	2	0	7	10	9	26	4	2	280					
8:00:00 AM	3	37	7	0	47	0	0	1	5	0	0	6	0	1	2	38	0	0	41	0	1	0	5	4	2	11	2	2	0	5	4	2	11	2	2	105					
8:15:00 AM	5	31	2	0	38	0	0	0	0	1	0	1	0	0	3	40	3	0	46	0	0	0	3	7	4	14	0	0	0	3	7	4	14	0	0	99					
Hourly Total	8	68	9	0	85	0	0	1	5	1	0	7	0	1	5	78	3	0	87	0	1	0	8	11	6	25	2	2	0	8	11	6	25	2	2	204					
4:00:00 PM	3	56	4	0	63	0	0	4	6	0	0	10	0	1	7	51	0	0	58	2	6	0	5	6	4	15	1	4	0	5	6	4	15	1	4	146					
4:15:00 PM	2	45	7	0	54	1	0	4	6	6	0	16	0	0	12	45	4	0	61	5	3	0	3	2	7	12	1	1	0	3	2	7	12	1	1	143					
4:30:00 PM	6	48	5	0	59	0	0	4	5	2	0	11	1	1	5	47	5	0	57	3	1	0	5	3	4	12	2	2	0	5	3	4	12	2	2	139					
4:45:00 PM	4	42	3	0	49	0	0	2	3	2	0	7	1	0	8	46	4	0	56	3	3	0	7	6	3	16	4	2	0	7	6	3	16	4	2	130					
Hourly Total	15	191	19	0	225	1	0	14	20	10	0	44	2	2	32	199	13	0	234	13	13	0	20	17	18	55	8	9	0	20	17	18	55	8	9	558					
5:00:00 PM	3	47	4	0	54	0	0	3	3	4	0	10	0	0	3	63	3	0	69	1	4	0	6	5	7	18	1	2	0	6	5	7	18	1	2	151					
5:15:00 PM	1	36	5	0	42	0	0	1	6	3	0	10	0	1	4	42	7	0	53	3	2	0	2	5	5	7	2	1	0	2	5	5	7	2	1	112					
5:30:00 PM	3	44	5	0	52	0	0	1	0	1	0	2	0	0	7	50	6	0	63	2	1	0	2	4	1	7	1	2	0	2	4	1	7	1	2	124					
5:45:00 PM	5	38	4	0	47	0	0	4	3	2	0	9	0	0	2	25	7	1	35	0	0	0	2	4	2	8	5	2	0	2	4	2	8	5	2	89					
Hourly Total	12	165	18	0	195	0	0	9	12	10	0	31	0	1	16	180	23	1	220	6	7	0	10	15	15	40	9	7	0	10	15	15	40	9	7	486					
Grand Total	55	528	52	0	635	1	1	38	45	30	0	114	2	6	64	587	47	1	702	19	21	0	47	56	52	155	24	21	0	47	56	52	155	24	21	1608					
% Approach	8.7%	83.1%	8.2%	0.0%	0.0%	0.0%	0.0%	33.3%	39.5%	26.3%	0.0%	0.0%	0.0%	0.0%	9.1%	83.6%	6.7%	0.1%	0.0%	0.0%	0.0%	0.0%	30.3%	36.1%	33.5%	0.0%	0.0%	0.0%	0.0%	0.0%	0.0%	0.0%	0.0%								
% Total	3.4%	32.9%	3.2%	0.0%	39.5%	0.0%	0.0%	2.4%	2.8%	1.9%	0.0%	7.1%	0.0%	0.0%	4.0%	36.6%	2.9%	0.1%	43.7%	0.0%	0.0%	0.0%	2.9%	3.5%	3.2%	0.0%	9.7%	0.0%	0.0%	9.7%	0.0%	0.0%	0.0%								
Lights	55	508	48	0	611	0	0	34	42	24	0	100	0	0	62	558	44	1	665	0	0	0	44	51	46	141	0	0	0	44	51	46	141	0	0	1517					
% Lights	100.0%	96.2%	92.3%	0.0%	96.2%	0.0%	0.0%	89.5%	83.3%	80.0%	0.0%	87.7%	0.0%	0.0%	86.9%	85.1%	93.8%	100.0%	94.7%	0.0%	0.0%	0.0%	93.6%	91.1%	88.5%	0.0%	91.0%	0.0%	0.0%	91.0%	0.0%	0.0%	94.8%								
Trucks	0	0	0	0	0	0	0	0	0	0	0	0	0	0	0	1	0	0	1	0	0	0	0	0	0	0	0	0	0	0	0	0	0	0	0	1					
% Trucks	0.0%	0.0%	0.0%	0.0%	0.0%	0.0%	0.0%	0.0%	0.0%	0.0%	0.0%	0.0%	0.0%	0.0%	0.0%	0.2%	0.0%	0.0%	0.1%	0.0%	0.0%	0.0%	0.0%	0.0%	0.0%	0.0%	0.0%	0.0%	0.0%	0.0%	0.0%	0.0%									
Buses	0	19	4	0	23	0	0	4	3	6	0	13	0	0	2	28	3	0	33	0	0	0	3	5	6	14	0	0	0	3	5	6	14	0	0	83					
% Buses	0.0%	3.6%	7.7%	0.0%	0.0%	0.0%	0.0%	0.0%	6.7%	20.0%	0.0%	0.0%	0.0%	0.0%	3.1%	4.8%	6.4%	0.0%	0.0%	0.0%	0.0%	0.0%	6.4%	8.9%	11.5%	0.0%	0.0%	0.0%	0.0%	6.4%	8.9%	11.5%	0.0%	0.0%	0.0%	5.2%					
Pedestrians	0	0	0	0	0	1	1	0	0	0	0	0	1	6	0	0	0	0	0	19	21	0	0	0	0	0	24	21	0	0	0	0	24	21	0	0					
% Pedestrians	0.0%	0.0%	0.0%	0.0%	0.0%	100.0%	100.0%	0.0%	0.0%	0.0%	0.0%	0.0%	50.0%	100.0%	0.0%	0.0%	0.0%	0.0%	0.0%	100.0%	100.0%	0.0%	0.0%	0.0%	0.0%	0.0%	100.0%	100.0%	0.0%	0.0%	0.0%	0.0%	100.0%	100.0%	0.0%	0.0%					
Bicycles on Crosswalk	0	0	0	0	0	0	0	0	0	0	0	0	1	0	0	0	0	0	0	0	0	0	0	0	0	0	0	0	0	0	0	0	0	0	0	0					
% Bicycles on Crosswalk	0.0%	0.0%	0.0%	0.0%	0.0%	0.0%	0.0%	0.0%	0.0%	0.0%	0.0%	0.0%	50.0%	0.0%	0.0%	0.0%	0.0%	0.0%	0.0%	0.0%	0.0%	0.0%	0.0%	0.0%	0.0%	0.0%	0.0%	0.0%	0.0%	0.0%	0.0%	0.0%									

Project : VBH Malta NY
 Site : Site 4
 Location : 42.948550, -73.790036
 Survey Date : 2021-04-28, Wednesday

Turning Movement Data Plot

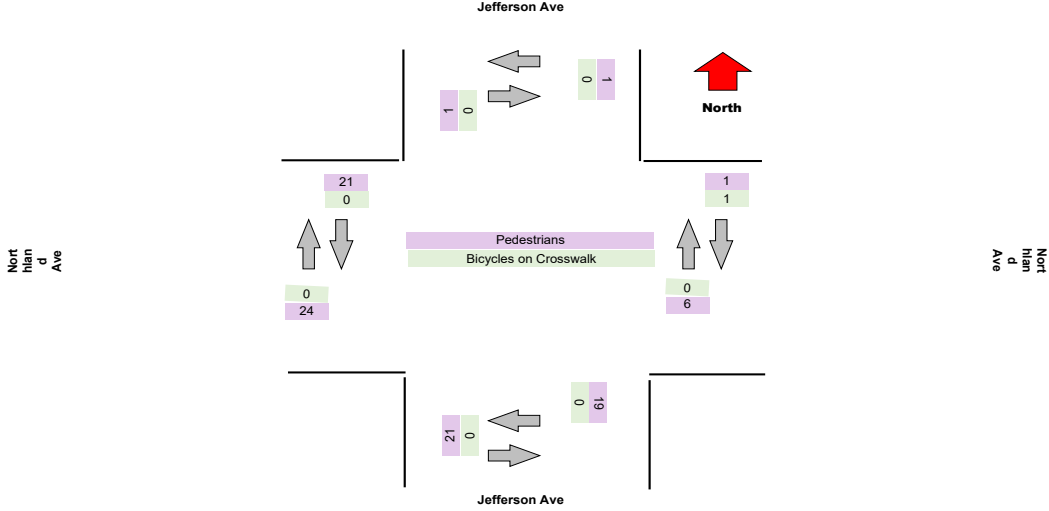
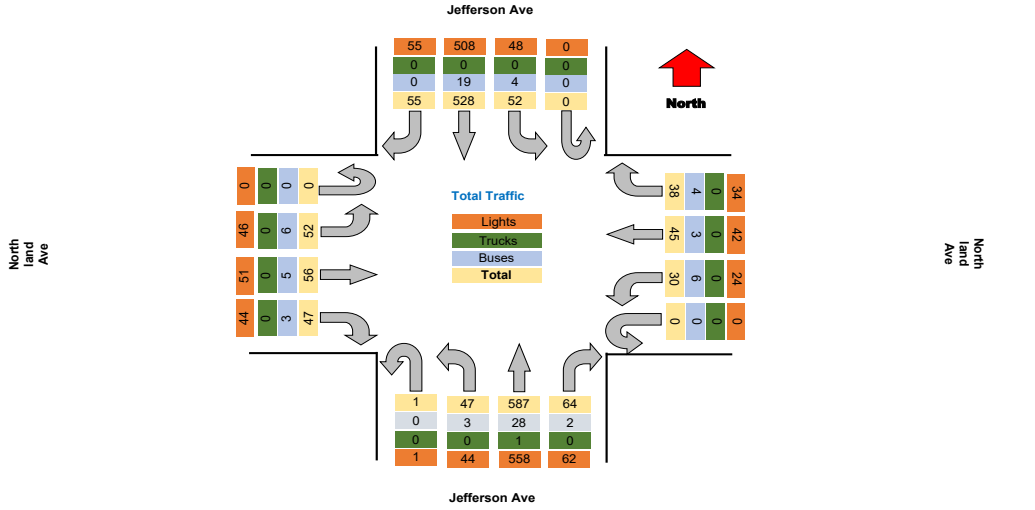

Turning Movement Peak Hour Data (AM)

7:30:00 AM

Leg Direction	Jefferson Ave				Northland Ave				Jefferson Ave				Northland Ave				Total						
	Southbound		Northbound		Westbound		Eastbound		Northbound		Eastbound		Westbound		Eastbound								
Start Time	Right	Thru	Left	U-Turn	App Total	Peds CW	Peds CCW	Right	Thru	Left	U-Turn	App Total	Peds CW	Peds CCW	Right	Thru	Left	U-Turn	App Total	Peds CW	Peds CCW	Total	
7:30:00 AM	5	31	2	0	38	0	0	1	0	1	0	2	0	0	2	30	4	0	36	0	0	84	
7:45:00 AM	6	25	2	0	33	0	1	7	4	2	0	14	0	0	4	30	1	0	35	0	0	91	
8:00:00 AM	3	37	7	0	47	0	0	1	5	0	0	6	0	1	2	38	0	0	41	0	1	105	
8:15:00 AM	5	31	2	0	38	0	0	0	0	1	0	1	0	0	3	40	3	0	46	0	0	99	
Grand Total	19	124	13	0	156	0	1	9	9	4	0	23	0	1	11	138	8	0	158	0	1	379	
% Approach	12.2%	79.5%	8.3%	0.0%	0.0%	0.0%	0.0%	39.1%	39.1%	17.4%	0.0%	0.0%	0.0%	0.0%	7.0%	87.3%	5.1%	0.0%	0.0%	0.0%	0.0%	0.0%	0.0%
% Total	5.0%	32.7%	3.4%	0.0%	41.2%	0.0%	0.0%	2.4%	2.4%	1.1%	0.0%	6.1%	0.0%	0.0%	2.9%	36.4%	2.1%	0.0%	41.7%	0.0%	0.0%	0.0%	0.0%
PHF	0.792	0.838	0.464	0.000	0.830	0.000	0.000	0.321	0.450	0.500	0.000	0.411	0.000	0.000	0.688	0.863	0.500	0.000	0.859	0.000	0.000	0.000	0.902
Lights	19	119	12	0	150	0	0	8	9	3	0	20	0	0	11	126	6	0	143	0	0	350	
% Lights	100.0%	96.0%	92.3%	0.0%	96.2%	0.0%	0.0%	88.9%	100.0%	75.0%	0.0%	87.0%	0.0%	0.0%	100.0%	91.3%	75.0%	0.0%	90.5%	0.0%	0.0%	92.3%	
Trucks	0	0	0	0	0	0	0	0	0	0	0	0	0	0	0	0	0	0	0	0	0	0	0
% Trucks	0.0%	0.0%	0.0%	0.0%	0.0%	0.0%	0.0%	0.0%	0.0%	0.0%	0.0%	0.0%	0.0%	0.0%	0.0%	0.0%	0.0%	0.0%	0.0%	0.0%	0.0%	0.0%	0.0%
Buses	0	5	1	0	6	0	0	1	0	1	0	2	0	0	0	12	2	0	14	0	0	27	
% Buses	0.0%	4.0%	7.7%	0.0%	0.0%	0.0%	0.0%	11.1%	0.0%	25.0%	0.0%	0.0%	0.0%	0.0%	0.0%	8.7%	25.0%	0.0%	0.0%	0.0%	0.0%	7.1%	
Pedestrians	0	0	0	0	0	0	1	0	0	0	0	0	1	0	0	0	0	0	0	0	1	2	0
% Pedestrians	0.0%	0.0%	0.0%	0.0%	0.0%	100.0%	100.0%	0.0%	0.0%	0.0%	0.0%	0.0%	0.0%	100.0%	0.0%	0.0%	0.0%	0.0%	0.0%	0.0%	0.0%	100.0%	0.0%
Bicycles on Crosswalk	0	0	0	0	0	0	0	0	0	0	0	0	0	0	0	0	0	0	0	0	0	0	0
% Bicycles on Crosswalk	0.0%	0.0%	0.0%	0.0%	0.0%	0.0%	0.0%	0.0%	0.0%	0.0%	0.0%	0.0%	0.0%	0.0%	0.0%	0.0%	0.0%	0.0%	0.0%	0.0%	0.0%	0.0%	0.0%

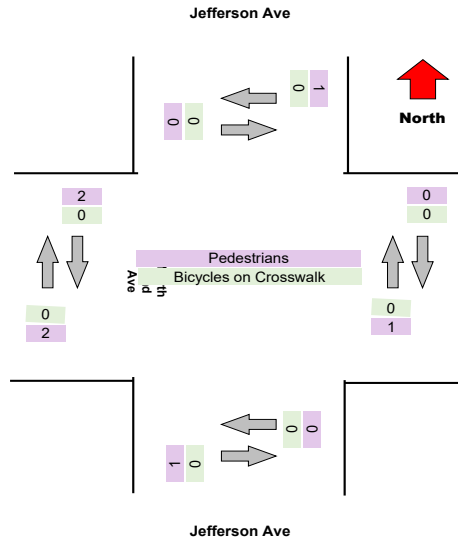
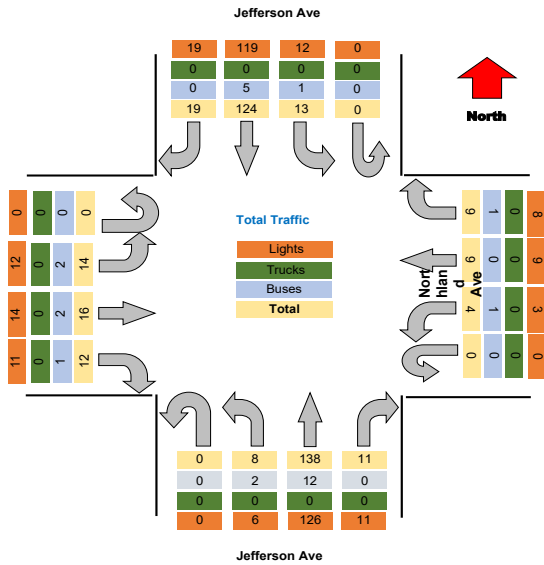

Turning Movement Peak Hour Data (PM)

5:00:00 PM

Leg Direction	Jefferson Ave								Northland Ave								Jefferson Ave								Northland Ave								Total
	Southbound				Westbound				Northbound				Eastbound				Southbound				Westbound				Northbound				Eastbound				
	Right	Thru	Left	U-Turn	App Total	Peds CW	Peds CCW		Right	Thru	Left	U-Turn	App Total	Peds CW	Peds CCW		Right	Thru	Left	U-Turn	App Total	Peds CW	Peds CCW		Right	Thru	Left	U-Turn	App Total	Peds CW	Peds CCW		
5:00:00 PM	3	47	4	0	54	0	0		3	3	4	0	10	0	0		3	63	3	0	69	1	4		6	5	7	0	18	1	2		151
5:15:00 PM	1	36	5	0	42	0	0		1	6	3	0	10	0	1		4	42	7	0	53	3	2		0	2	5	0	7	2	1		112
5:30:00 PM	3	44	5	0	52	0	0		1	0	1	0	2	0	0		7	50	6	0	63	2	1		2	4	1	0	7	1	2		124
5:45:00 PM	5	39	4	0	47	0	0		4	3	2	0	9	0	0		2	25	7	1	35	0	0		2	4	2	0	8	5	2		99
Grand Total	12	165	18	0	195	0	0		9	12	10	0	31	0	1		16	190	23	1	230	3	7		10	15	15	0	40	3	7		488
% Approach	6.2%	84.6%	9.2%	0.0%	0.0%	0.0%	0.0%		29.0%	38.7%	32.3%	0.0%	0.0%	0.0%	0.0%		7.3%	81.6%	10.5%	0.5%	0.0%	0.0%	0.0%		25.0%	37.5%	37.5%	0.0%	0.0%	0.0%	0.0%		
% Total	2.5%	34.0%	3.7%	0.0%	40.1%	0.0%	0.0%		1.9%	2.5%	2.1%	0.0%	6.4%	0.0%	0.0%		3.3%	37.0%	4.7%	0.2%	45.3%	0.0%	0.0%		2.1%	3.1%	3.1%	0.0%	8.2%	0.0%	0.0%		
PHF	0.600	0.878	0.900	0.000	0.903	0.000	0.000		0.563	0.500	0.625	0.000	0.775	0.000	0.000		0.571	0.714	0.821	0.250	0.787	0.000	0.000		0.417	0.750	0.536	0.000	0.556	0.000	0.000		0.805
Lights	12	162	18	0	192	0	0		9	12	10	0	31	0	0		16	176	23	1	216	0	0		10	15	15	0	40	0	0		479
% Lights	100.0%	98.2%	100.0%	0.0%	98.5%	0.0%	0.0%		100.0%	100.0%	100.0%	0.0%	100.0%	0.0%	0.0%		100.0%	97.8%	100.0%	100.0%	98.2%	0.0%	0.0%		100.0%	100.0%	100.0%	0.0%	100.0%	0.0%	0.0%		98.6%
Trucks	0	0	0	0	0	0	0		0	0	0	0	0	0	0		0	0	0	0	0	0	0		0	0	0	0	0	0	0		0
% Trucks	0.0%	0.0%	0.0%	0.0%	0.0%	0.0%	0.0%		0.0%	0.0%	0.0%	0.0%	0.0%	0.0%	0.0%		0.0%	0.0%	0.0%	0.0%	0.0%	0.0%	0.0%		0.0%	0.0%	0.0%	0.0%	0.0%	0.0%	0.0%		0.0%
Buses	0	3	0	0	3	0	0		0	0	0	0	0	0	0		0	4	0	0	4	0	0		0	0	0	0	0	0	0		7
% Buses	0.0%	1.8%	0.0%	0.0%	0.0%	0.0%	0.0%		0.0%	0.0%	0.0%	0.0%	0.0%	0.0%	0.0%		0.0%	2.2%	0.0%	0.0%	0.0%	0.0%	0.0%		0.0%	0.0%	0.0%	0.0%	0.0%	0.0%	0.0%		1.4%
Pedestrians	0	0	0	0	0	0	0		0	0	0	0	0	1	0		0	0	0	0	0	6	7		0	0	0	0	0	9	7		0
% Pedestrians	0.0%	0.0%	0.0%	0.0%	0.0%	0.0%	0.0%		0.0%	0.0%	0.0%	0.0%	0.0%	0.0%	100.0%		0.0%	0.0%	0.0%	0.0%	0.0%	100.0%	100.0%		0.0%	0.0%	0.0%	0.0%	0.0%	100.0%	100.0%		0.0%
Bicycles on Crosswalk	0	0	0	0	0	0	0		0	0	0	0	0	0	0		0	0	0	0	0	0	0		0	0	0	0	0	0	0		0
% Bicycles on Crosswalk	0.0%	0.0%	0.0%	0.0%	0.0%	0.0%	0.0%		0.0%	0.0%	0.0%	0.0%	0.0%	0.0%	0.0%		0.0%	0.0%	0.0%	0.0%	0.0%	0.0%	0.0%		0.0%	0.0%	0.0%	0.0%	0.0%	0.0%	0.0%		0.0%

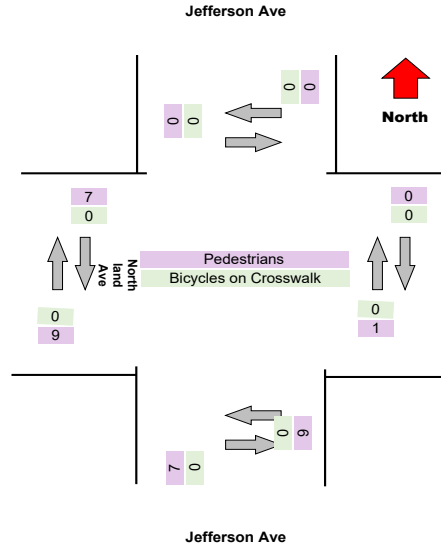
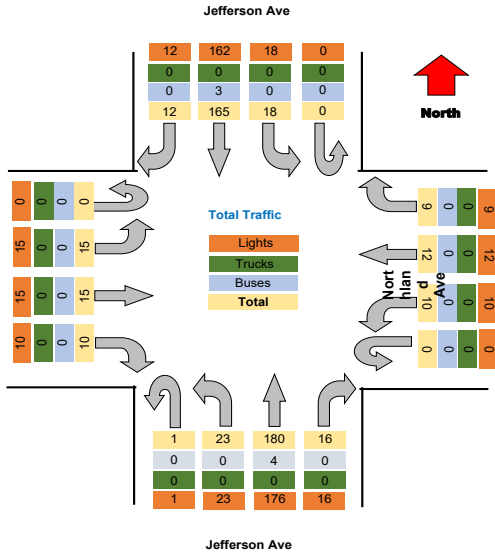

Intersection: Elm St Pine St
 Location: Kennett Square, PA
 Site: 01
 Survey Date: Wednesday, 04-28-2021
 GPS: 42.948550, -72.790034



Project	LaBella
Project Code	LaBella
Site Name	31
Legs and Movements	All Processed Legs & Movements
Bin Size	15 minutes
Survey Date	2021-11-02, Tuesday
Location	31
Latitude and Longitude	42.917042, -78.853981

	Start	End	PHF
Forced Peak AM	2021/11/02 07:30:00	2021/11/02 08:30:00	0.903225806
Forced Peak PM	2021/11/02 16:30:00	2021/11/02 17:30:00	0.917938931
AM Peak	2021/11/02 07:30:00	2021/11/02 08:30:00	0.903225806
PM Peak	2021/11/02 17:00:00	2021/11/02 18:00:00	0.849236641

Turning Movement Data

Leg Direction	Jefferson Ave Southbound						Brunswick Blvd Westbound						Jefferson Ave Northbound						Total
	Thru	Left	U-Turn	App Total	Peds CW	Peds CCW	Right	Left	U-Turn	App Total	Peds CW	Peds CCW	Right	Thru	U-Turn	App Total	Peds CW	Peds CCW	
Start Time																			
6:30:00 AM	11	2	0	13	0	0	2	1	0	3	0	2	3	14	0	19	0	0	
6:45:00 AM	13	0	0	13	0	0	1	3	0	4	0	0	3	20	0	23	0	0	
Hourly Total	24	2	0	26	0	0	3	4	0	7	0	2	6	34	0	42	0	0	
7:00:00 AM	12	0	0	12	0	0	2	2	0	4	1	0	4	41	0	46	0	0	
7:15:00 AM	15	0	0	15	0	0	4	4	0	8	0	1	2	23	0	26	1	1	
7:30:00 AM	13	1	0	14	0	0	7	4	0	11	1	1	5	19	0	26	0	1	
7:45:00 AM	22	2	0	24	0	0	1	3	0	4	0	0	6	28	0	34	0	0	
Hourly Total	62	3	0	65	0	0	14	13	0	27	2	2	17	111	0	132	1	2	
8:00:00 AM	20	4	0	24	0	0	3	3	0	6	1	1	7	17	0	26	0	0	
8:15:00 AM	27	1	0	28	0	0	3	7	0	10	0	0	4	13	0	17	0	0	
Hourly Total	47	5	0	52	0	0	6	10	0	16	1	1	11	30	0	43	0	0	
4:00:00 PM	46	5	0	51	0	0	4	6	0	10	0	2	9	49	0	58	0	0	
4:15:00 PM	46	3	0	49	0	0	4	5	1	10	3	2	13	52	0	65	0	0	
4:30:00 PM	52	1	0	53	4	2	4	4	0	8	2	2	11	52	0	63	0	0	
4:45:00 PM	39	3	0	42	0	0	7	6	0	13	2	0	9	55	0	64	1	0	
Hourly Total	183	12	0	195	4	2	19	21	1	41	7	6	42	208	0	250	1	0	
5:00:00 PM	39	6	0	45	0	0	5	7	0	12	0	0	18	56	0	74	0	1	
5:15:00 PM	41	2	0	43	0	0	3	5	0	8	0	0	5	51	0	56	1	0	
5:30:00 PM	35	3	0	38	0	0	6	7	0	13	2	3	17	49	0	66	0	0	
5:45:00 PM	28	0	0	28	0	0	1	5	0	6	0	1	11	45	0	56	0	0	
Hourly Total	143	11	0	154	0	0	15	24	0	39	2	4	51	201	0	252	1	1	
Grand Total	459	33	0	492	4	2	57	72	1	130	12	15	127	584	0	719	3	3	
% Approach	93.3%	6.7%	0.0%	0.0%	0.0%	0.0%	43.8%	55.4%	0.8%	0.0%	0.0%	0.0%	17.7%	81.2%	0.0%	0.0%	0.0%	0.0%	
% Total	34.2%	2.5%	0.0%	36.7%	0.0%	0.0%	4.3%	5.4%	0.1%	9.7%	0.0%	0.0%	9.5%	43.5%	0.0%	53.6%	0.0%	0.0%	
Lights	448	33	0	481	0	0	56	72	1	129	0	0	126	572	0	698	0	0	
% Lights	97.6%	100.0%	0.0%	97.8%	0.0%	0.0%	98.2%	100.0%	100.0%	99.2%	0.0%	0.0%	99.2%	97.9%	0.0%	97.1%	0.0%	0.0%	
Trucks	0	0	0	0	0	0	0	0	0	0	0	0	0	0	0	0	0	0	
% Trucks	0.0%	0.0%	0.0%	0.0%	0.0%	0.0%	0.0%	0.0%	0.0%	0.0%	0.0%	0.0%	0.0%	0.0%	0.0%	0.0%	0.0%	0.0%	
Buses	10	0	0	10	0	0	1	0	0	1	0	0	1	11	0	12	0	0	
% Buses	2.2%	0.0%	0.0%	0.0%	0.0%	0.0%	0.0%	0.0%	0.0%	0.0%	0.0%	0.0%	0.8%	1.9%	0.0%	0.0%	0.0%	0.0%	
Pedestrians	0	0	0	0	2	2	0	0	0	0	12	14	0	0	0	0	3	3	
% Pedestrians	0.0%	0.0%	0.0%	0.0%	50.0%	100.0%	0.0%	0.0%	0.0%	0.0%	100.0%	93.3%	0.0%	0.0%	0.0%	0.0%	100.0%	100.0%	
Bicycles on Crosswalk	0	0	0	0	2	0	0	0	0	0	0	1	0	0	0	0	0	0	
% Bicycles on Crosswalk	0.0%	0.0%	0.0%	0.0%	50.0%	0.0%	0.0%	0.0%	0.0%	0.0%	0.0%	6.7%	0.0%	0.0%	0.0%	0.0%	0.0%	0.0%	

Turning Movement Data Plot

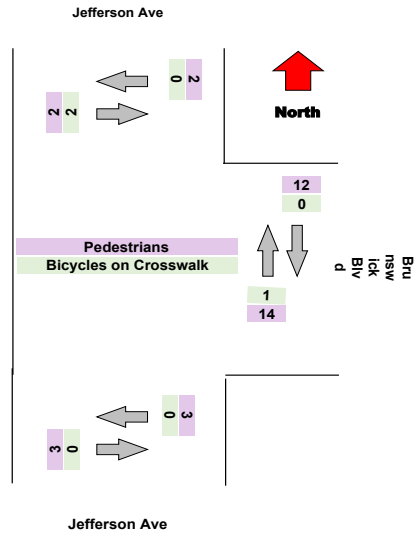
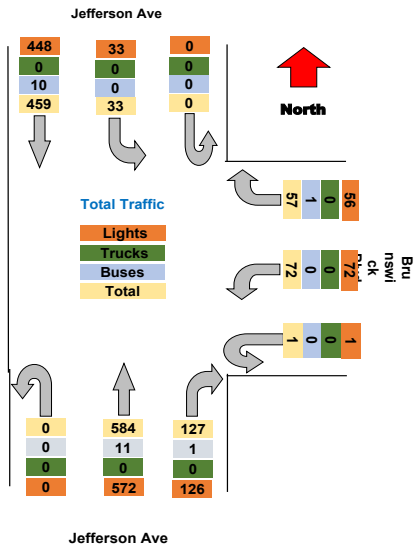

Turning Movement Peak Hour Data (AM)
 7:30:00 AM

Leg Direction	Jefferson Ave Southbound						Brunswick Blvd Westbound						Jefferson Ave Northbound						Total
	Thru	Left	U-Turn	App Total	Peds CW	Peds CCW	Right	Left	U-Turn	App Total	Peds CW	Peds CCW	Right	Thru	U-Turn	App Total	Peds CW	Peds CCW	
7:30:00 AM	13	1	0	14	0	0	7	4	0	11	1	1	5	19	0	26	0	1	51
7:45:00 AM	22	2	0	24	0	0	1	3	0	4	0	0	6	28	0	34	0	0	62
8:00:00 AM	20	4	0	24	0	0	3	3	0	6	1	1	7	17	0	26	0	0	56
8:15:00 AM	27	1	0	28	0	0	3	7	0	10	0	0	4	13	0	17	0	0	55
Grand Total	82	8	0	90	0	0	14	17	0	31	2	2	22	77	0	103	0	1	224
% Approach	91.1%	8.9%	0.0%	0.0%	0.0%	0.0%	45.2%	54.8%	0.0%	0.0%	0.0%	0.0%	21.4%	74.8%	0.0%	0.0%	0.0%	0.0%	
% Total	36.6%	3.6%	0.0%	40.2%	0.0%	0.0%	6.3%	7.6%	0.0%	13.8%	0.0%	0.0%	9.8%	34.4%	0.0%	46.0%	0.0%	0.0%	
PHF	0.759	0.500	0.000	0.804	0.000	0.000	0.500	0.607	0.000	0.705	0.000	0.000	0.786	0.688	0.000	0.757	0.000	0.000	0.903
Lights	80	8	0	88	0	0	13	17	0	30	0	0	21	74	0	95	0	0	213
% Lights	97.6%	100.0%	0.0%	97.8%	0.0%	0.0%	92.9%	100.0%	0.0%	96.8%	0.0%	0.0%	95.5%	96.1%	0.0%	92.2%	0.0%	0.0%	95.1%
Trucks	0	0	0	0	0	0	0	0	0	0	0	0	0	0	0	0	0	0	0
% Trucks	0.0%	0.0%	0.0%	0.0%	0.0%	0.0%	0.0%	0.0%	0.0%	0.0%	0.0%	0.0%	0.0%	0.0%	0.0%	0.0%	0.0%	0.0%	0.0%
Buses	2	0	0	2	0	0	1	0	0	1	0	0	1	3	0	4	0	0	7
% Buses	2.4%	0.0%	0.0%	0.0%	0.0%	0.0%	7.1%	0.0%	0.0%	0.0%	0.0%	0.0%	4.5%	3.9%	0.0%	0.0%	0.0%	0.0%	3.1%
Pedestrians	0	0	0	0	0	0	0	0	0	2	2	0	0	0	0	0	0	1	0
% Pedestrians	0.0%	0.0%	0.0%	0.0%	0.0%	0.0%	0.0%	0.0%	0.0%	0.0%	100.0%	100.0%	0.0%	0.0%	0.0%	0.0%	0.0%	100.0%	0.0%
Bicycles on Crosswalk	0	0	0	0	0	0	0	0	0	0	0	0	0	0	0	0	0	0	0
% Bicycles on Crosswalk	0.0%	0.0%	0.0%	0.0%	0.0%	0.0%	0.0%	0.0%	0.0%	0.0%	0.0%	0.0%	0.0%	0.0%	0.0%	0.0%	0.0%	0.0%	0.0%

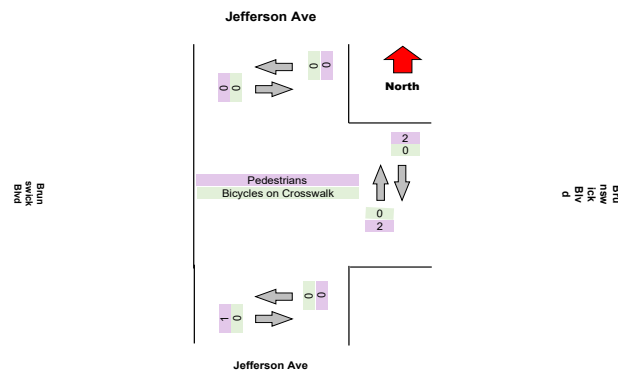
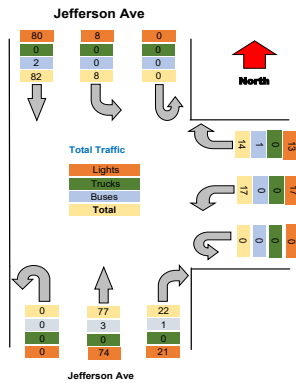

Turning Movement Peak Hour Data (PM)
 5:00:00 PM

Leg Direction	Jefferson Ave Southbound						Brunswick Blvd Westbound						Jefferson Ave Northbound						Total
	Thru	Left	U-Turn	App Total	Peds CW	Peds CCW	Right	Left	U-Turn	App Total	Peds CW	Peds CCW	Right	Thru	U-Turn	App Total	Peds CW	Peds CCW	
5:00:00 PM	39	6	0	45	0	0	5	7	0	12	0	0	18	56	0	74	0	1	131
5:15:00 PM	41	2	0	43	0	0	3	5	0	8	0	0	5	51	0	56	1	0	107
5:30:00 PM	35	3	0	38	0	0	6	7	0	13	2	3	17	49	0	66	0	0	117
5:45:00 PM	28	0	0	28	0	0	1	5	0	6	0	1	11	45	0	56	0	0	90
Grand Total	143	11	0	154	0	0	15	24	0	39	2	4	51	201	0	252	1	1	445
% Approach	92.9%	7.1%	0.0%	0.0%	0.0%	0.0%	38.5%	61.5%	0.0%	0.0%	0.0%	0.0%	20.2%	79.8%	0.0%	0.0%	0.0%	0.0%	
% Total	32.1%	2.5%	0.0%	34.6%	0.0%	0.0%	3.4%	5.4%	0.0%	8.8%	0.0%	0.0%	11.5%	45.2%	0.0%	56.6%	0.0%	0.0%	
PHF	0.872	0.458	0.000	0.856	0.000	0.000	0.625	0.857	0.000	0.750	0.000	0.000	0.708	0.897	0.000	0.851	0.000	0.000	0.849
Lights	141	11	0	152	0	0	15	24	0	39	0	0	51	199	0	250	0	0	441
% Lights	98.6%	100.0%	0.0%	98.7%	0.0%	0.0%	100.0%	100.0%	0.0%	100.0%	0.0%	0.0%	100.0%	99.0%	0.0%	99.2%	0.0%	0.0%	99.1%
Trucks	0	0	0	0	0	0	0	0	0	0	0	0	0	0	0	0	0	0	0
% Trucks	0.0%	0.0%	0.0%	0.0%	0.0%	0.0%	0.0%	0.0%	0.0%	0.0%	0.0%	0.0%	0.0%	0.0%	0.0%	0.0%	0.0%	0.0%	0.0%
Buses	2	0	0	2	0	0	0	0	0	0	0	0	0	0	0	2	0	0	4
% Buses	1.4%	0.0%	0.0%	0.0%	0.0%	0.0%	0.0%	0.0%	0.0%	0.0%	0.0%	0.0%	0.0%	1.0%	0.0%	0.0%	0.0%	0.0%	0.9%
Pedestrians	0	0	0	0	0	0	0	0	0	0	2	4	0	0	0	0	1	1	0
% Pedestrians	0.0%	0.0%	0.0%	0.0%	0.0%	0.0%	0.0%	0.0%	0.0%	0.0%	100.0%	100.0%	0.0%	0.0%	0.0%	0.0%	100.0%	100.0%	0.0%
Bicycles on Crosswalk	0	0	0	0	0	0	0	0	0	0	0	0	0	0	0	0	0	0	0
% Bicycles on Crosswalk	0.0%	0.0%	0.0%	0.0%	0.0%	0.0%	0.0%	0.0%	0.0%	0.0%	0.0%	0.0%	0.0%	0.0%	0.0%	0.0%	0.0%	0.0%	0.0%

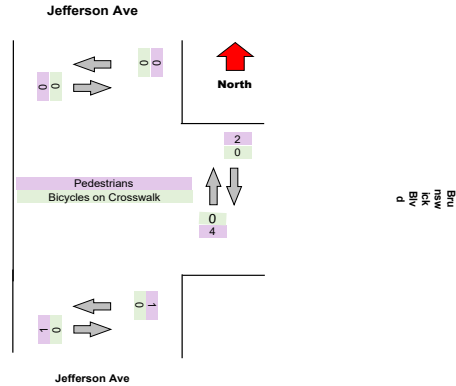
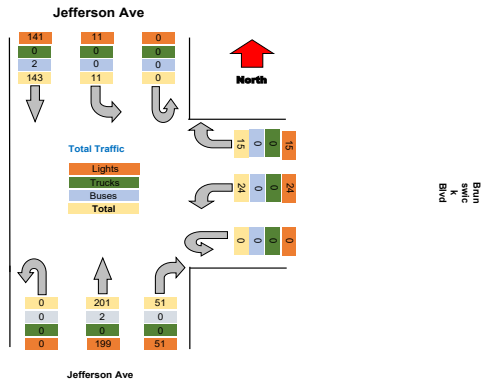

Turning Movement Data Plot

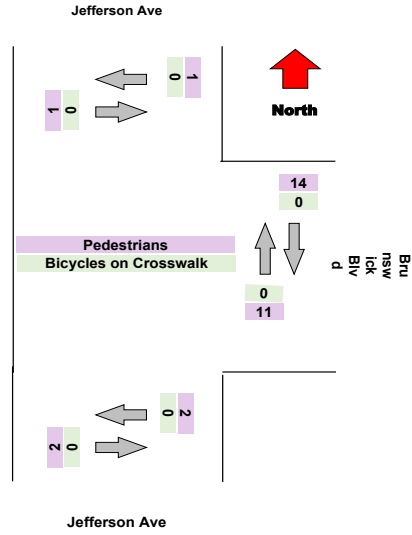
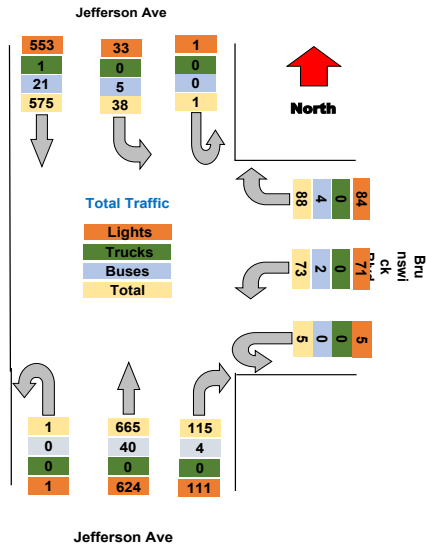

Turning Movement Peak Hour Data (AM)
 7:30:00 AM

Leg Direction	Jefferson Ave Southbound						Brunswick Blvd Westbound						Jefferson Ave Northbound						Total
	Thru	Left	U-Turn	App Total	Peds CW	Peds CCW	Right	Left	U-Turn	App Total	Peds CW	Peds CCW	Right	Thru	U-Turn	App Total	Peds CW	Peds CCW	
7:30:00 AM	24	1	0	25	0	0	6	6	0	12	0	2	4	29	0	35	0	1	72
7:45:00 AM	51	4	0	55	0	1	4	6	1	12	2	0	8	21	0	31	0	0	98
8:00:00 AM	28	2	0	30	0	0	4	7	0	11	0	1	7	41	0	49	0	1	90
8:15:00 AM	27	1	0	28	0	0	4	4	0	8	1	0	2	41	0	44	0	0	80
Grand Total	130	8	0	138	0	1	18	23	1	43	3	3	21	132	0	159	0	2	340
% Approach	94.2%	5.8%	0.0%	0.0%	0.0%	0.0%	41.9%	53.5%	2.3%	0.0%	0.0%	0.0%	13.2%	83.0%	0.0%	0.0%	0.0%	0.0%	72
% Total	38.2%	2.4%	0.0%	40.6%	0.0%	0.0%	5.3%	6.8%	0.3%	12.6%	0.0%	0.0%	6.2%	38.8%	0.0%	46.8%	0.0%	0.0%	98
PHF	0.637	0.500	0.000	0.627	0.000	0.000	0.750	0.821	0.250	0.896	0.000	0.000	0.656	0.805	0.000	0.811	0.000	0.000	0.867
Lights	124	7	0	131	0	0	16	22	1	39	0	0	20	120	0	140	0	0	310
% Lights	95.4%	87.5%	0.0%	94.9%	0.0%	0.0%	88.9%	95.7%	100.0%	90.7%	0.0%	0.0%	95.2%	90.9%	0.0%	88.1%	0.0%	0.0%	91.2%
Trucks	0	0	0	0	0	0	0	0	0	0	0	0	0	0	0	0	0	0	0
% Trucks	0.0%	0.0%	0.0%	0.0%	0.0%	0.0%	0.0%	0.0%	0.0%	0.0%	0.0%	0.0%	0.0%	0.0%	0.0%	0.0%	0.0%	0.0%	0.0%
Buses	6	1	0	7	0	0	2	1	0	3	0	0	1	12	0	13	0	0	23
% Buses	4.6%	12.5%	0.0%	0.0%	0.0%	0.0%	11.1%	4.3%	0.0%	0.0%	0.0%	0.0%	4.8%	9.1%	0.0%	0.0%	0.0%	0.0%	6.8%
Pedestrians	0	0	0	0	0	1	0	0	0	0	3	3	0	0	0	0	0	2	0
% Pedestrians	0.0%	0.0%	0.0%	0.0%	0.0%	100.0%	0.0%	0.0%	0.0%	0.0%	100.0%	100.0%	0.0%	0.0%	0.0%	0.0%	0.0%	100.0%	0.0%
Bicycles on Crosswalk	0	0	0	0	0	0	0	0	0	0	0	0	0	0	0	0	0	0	0
% Bicycles on Crosswalk	0.0%	0.0%	0.0%	0.0%	0.0%	0.0%	0.0%	0.0%	0.0%	0.0%	0.0%	0.0%	0.0%	0.0%	0.0%	0.0%	0.0%	0.0%	0.0%

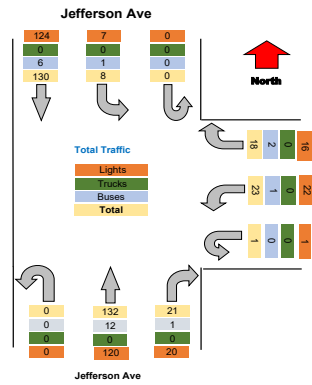

Brunswick Blvd

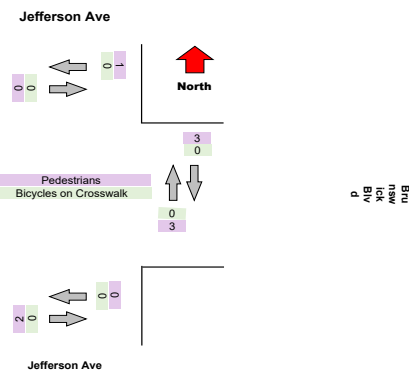

Brunswick Blvd

Turning Movement Peak Hour Data (PM)

5:00:00 PM

Leg Direction	Jefferson Ave Southbound						Brunswick Blvd Westbound						Jefferson Ave Northbound						Total
	Thru	Left	U-Turn	App Total	Peds CW	Peds CCW	Right	Left	U-Turn	App Total	Peds CW	Peds CCW	Right	Thru	U-Turn	App Total	Peds CW	Peds CCW	
5:00:00 PM	43	2	0	45	0	0	7	6	0	13	0	0	11	61	0	72	0	0	130
5:15:00 PM	41	1	0	42	1	0	3	8	0	11	0	0	10	64	0	74	0	0	127
5:30:00 PM	47	2	0	49	0	0	7	5	1	13	0	0	5	58	0	63	0	0	125
5:45:00 PM	38	3	0	41	0	0	6	4	0	10	0	1	13	45	1	59	1	0	110
Grand Total	169	8	0	177	1	0	23	23	1	47	0	1	39	228	1	268	1	0	492
% Approach	95.5%	4.5%	0.0%	0.0%	0.0%	0.0%	48.9%	48.9%	2.1%	0.0%	0.0%	0.0%	14.6%	85.1%	0.4%	0.0%	0.0%	0.0%	
% Total	34.3%	1.6%	0.0%	36.0%	0.0%	0.0%	4.7%	4.7%	0.2%	9.6%	0.0%	0.0%	7.9%	46.3%	0.2%	54.5%	0.0%	0.0%	
PHF	0.899	0.667	0.000	0.903	0.000	0.000	0.821	0.719	0.250	0.904	0.000	0.000	0.750	0.891	0.250	0.905	0.000	0.000	0.946
Lights	166	8	0	174	0	0	23	22	1	46	0	0	38	219	1	258	0	0	478
% Lights	98.2%	100.0%	0.0%	98.3%	0.0%	0.0%	100.0%	95.7%	100.0%	97.9%	0.0%	0.0%	97.4%	96.1%	100.0%	96.3%	0.0%	0.0%	97.2%
Trucks	0	0	0	0	0	0	0	0	0	0	0	0	0	0	0	0	0	0	0
% Trucks	0.0%	0.0%	0.0%	0.0%	0.0%	0.0%	0.0%	0.0%	0.0%	0.0%	0.0%	0.0%	0.0%	0.0%	0.0%	0.0%	0.0%	0.0%	0.0%
Buses	3	0	0	3	0	0	0	1	0	1	0	0	0	9	0	10	0	0	14
% Buses	1.8%	0.0%	0.0%	0.0%	0.0%	0.0%	0.0%	4.3%	0.0%	0.0%	0.0%	0.0%	2.6%	3.9%	0.0%	0.0%	0.0%	0.0%	2.8%
Pedestrians	0	0	0	0	1	0	0	0	0	0	1	0	0	0	0	1	0	0	0
% Pedestrians	0.0%	0.0%	0.0%	0.0%	100.0%	0.0%	0.0%	0.0%	0.0%	0.0%	100.0%	0.0%	0.0%	0.0%	0.0%	0.0%	100.0%	0.0%	0.0%
Bicycles on Crosswalk	0	0	0	0	0	0	0	0	0	0	0	0	0	0	0	0	0	0	0
% Bicycles on Crosswalk	0.0%	0.0%	0.0%	0.0%	0.0%	0.0%	0.0%	0.0%	0.0%	0.0%	0.0%	0.0%	0.0%	0.0%	0.0%	0.0%	0.0%	0.0%	0.0%

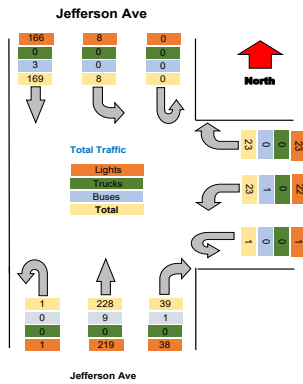

Brunswick Blvd

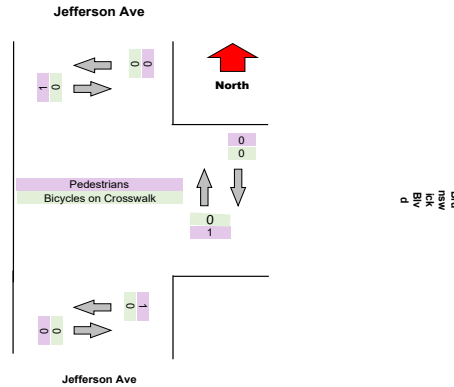

Brunswick Blvd

Turning Movement Data Plot

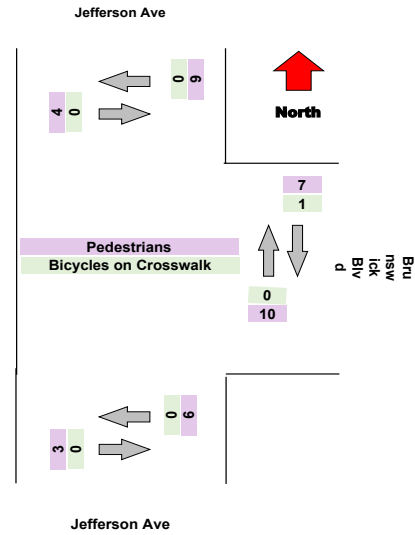
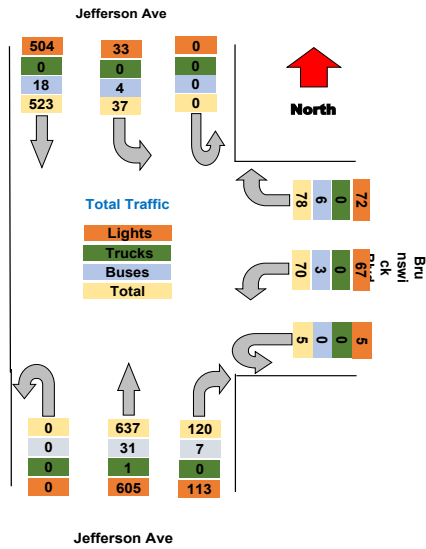

Turning Movement Peak Hour Data (AM)

7:30:00 AM

Leg Direction	Jefferson Ave Southbound						Brunswick Blvd Westbound						Jefferson Ave Northbound						Total
	Thru	Left	U-Turn	App Total	Peds CW	Peds CCW	Right	Left	U-Turn	App Total	Peds CW	Peds CCW	Right	Thru	U-Turn	App Total	Peds CW	Peds CCW	
7:30:00 AM	32	2	0	34	0	0	8	7	0	15	0	0	0	28	0	28	0	0	77
7:45:00 AM	29	1	0	30	0	1	5	7	0	13	0	0	3	34	0	37	0	0	80
8:00:00 AM	38	2	0	40	0	0	4	4	1	9	1	1	11	37	0	50	0	0	99
8:15:00 AM	31	2	0	33	0	0	7	3	1	11	0	0	6	41	0	47	0	0	91
Grand Total	130	7	0	137	0	1	24	21	2	48	1	1	20	140	0	162	0	0	347
% Approach	94.9%	5.1%	0.0%	0.0%	0.0%	0.0%	50.0%	43.8%	4.2%	0.0%	0.0%	0.0%	12.3%	86.4%	0.0%	0.0%	0.0%	0.0%	
% Total	37.5%	2.0%	0.0%	39.5%	0.0%	0.0%	6.9%	6.1%	0.6%	13.8%	0.0%	0.0%	5.8%	40.3%	0.0%	46.7%	0.0%	0.0%	
PHF	0.855	0.875	0.000	0.856	0.000	0.000	0.750	0.750	0.500	0.800	0.000	0.000	0.455	0.854	0.000	0.810	0.000	0.000	0.876
Lights	125	6	0	131	0	0	20	20	2	42	0	0	18	128	0	146	0	0	319
% Lights	96.2%	85.7%	0.0%	95.6%	0.0%	0.0%	83.3%	95.2%	100.0%	87.5%	0.0%	0.0%	90.0%	91.4%	0.0%	90.1%	0.0%	0.0%	91.9%
Trucks	0	0	0	0	0	0	0	0	0	0	0	0	0	0	0	0	0	0	0
% Trucks	0.0%	0.0%	0.0%	0.0%	0.0%	0.0%	0.0%	0.0%	0.0%	0.0%	0.0%	0.0%	0.0%	0.0%	0.0%	0.0%	0.0%	0.0%	0.0%
Buses	5	1	0	6	0	0	4	1	0	5	0	0	2	12	0	14	0	0	25
% Buses	3.8%	14.3%	0.0%	0.0%	0.0%	0.0%	16.7%	4.8%	0.0%	0.0%	0.0%	0.0%	10.0%	8.6%	0.0%	0.0%	0.0%	0.0%	7.2%
Pedestrians	0	0	0	0	0	1	0	0	0	0	1	1	0	0	0	0	0	0	0
% Pedestrians	0.0%	0.0%	0.0%	0.0%	0.0%	100.0%	0.0%	0.0%	0.0%	0.0%	100.0%	100.0%	0.0%	0.0%	0.0%	0.0%	0.0%	0.0%	0.0%
Bicycles on Crosswalk	0	0	0	0	0	0	0	0	0	0	0	0	0	0	0	0	0	0	0
% Bicycles on Crosswalk	0.0%	0.0%	0.0%	0.0%	0.0%	0.0%	0.0%	0.0%	0.0%	0.0%	0.0%	0.0%	0.0%	0.0%	0.0%	0.0%	0.0%	0.0%	0.0%



Brunswick Blvd

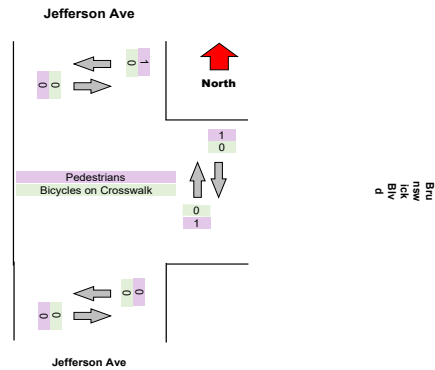

Brunswick Blvd

Turning Movement Peak Hour Data (PM)
 5:00:00 PM

Leg Direction	Jefferson Ave Southbound						Brunswick Blvd Westbound						Jefferson Ave Northbound						Total
	Thru	Left	U-Turn	App Total	Peds CW	Peds CCW	Right	Left	U-Turn	App Total	Peds CW	Peds CCW	Right	Thru	U-Turn	App Total	Peds CW	Peds CCW	
5:00:00 PM	49	2	0	51	1	2	7	5	0	12	0	1	16	63	0	79	4	3	142
5:15:00 PM	30	2	0	32	0	0	4	2	0	6	1	0	6	50	0	56	0	0	94
5:30:00 PM	47	3	0	50	0	3	8	4	1	13	2	2	13	59	0	72	0	0	135
5:45:00 PM	32	4	0	36	2	0	8	4	0	12	0	1	9	31	0	40	1	0	88
Grand Total	158	11	0	169	3	5	27	15	1	43	3	4	44	203	0	247	5	3	459
% Approach	93.5%	6.5%	0.0%	0.0%	0.0%	0.0%	62.8%	34.9%	2.3%	0.0%	0.0%	0.0%	17.8%	82.2%	0.0%	0.0%	0.0%	0.0%	0.0%
% Total	34.4%	2.4%	0.0%	36.8%	0.0%	0.0%	5.9%	3.3%	0.2%	9.4%	0.0%	0.0%	9.6%	44.2%	0.0%	53.8%	0.0%	0.0%	0.0%
PHF	0.806	0.688	0.000	0.828	0.000	0.000	0.844	0.750	0.250	0.827	0.000	0.000	0.688	0.806	0.000	0.782	0.000	0.000	0.808
Lights	155	11	0	166	0	0	27	15	1	43	0	0	43	198	0	241	0	0	450
% Lights	98.1%	100.0%	0.0%	98.2%	0.0%	0.0%	100.0%	100.0%	100.0%	100.0%	0.0%	0.0%	97.7%	97.5%	0.0%	97.6%	0.0%	0.0%	98.0%
Trucks	0	0	0	0	0	0	0	0	0	0	0	0	0	0	0	0	0	0	0
% Trucks	0.0%	0.0%	0.0%	0.0%	0.0%	0.0%	0.0%	0.0%	0.0%	0.0%	0.0%	0.0%	0.0%	0.0%	0.0%	0.0%	0.0%	0.0%	0.0%
Buses	3	0	0	3	0	0	0	0	0	0	0	0	1	5	0	6	0	0	9
% Buses	1.9%	0.0%	0.0%	0.0%	0.0%	0.0%	0.0%	0.0%	0.0%	0.0%	0.0%	0.0%	2.3%	2.5%	0.0%	0.0%	0.0%	0.0%	2.0%
Pedestrians	0	0	0	0	3	5	0	0	0	0	3	4	0	0	0	0	5	3	0
% Pedestrians	0.0%	0.0%	0.0%	0.0%	100.0%	100.0%	0.0%	0.0%	0.0%	0.0%	100.0%	100.0%	0.0%	0.0%	0.0%	0.0%	100.0%	100.0%	0.0%
Bicycles on Crosswalk	0	0	0	0	0	0	0	0	0	0	0	0	0	0	0	0	0	0	0
% Bicycles on Crosswalk	0.0%	0.0%	0.0%	0.0%	0.0%	0.0%	0.0%	0.0%	0.0%	0.0%	0.0%	0.0%	0.0%	0.0%	0.0%	0.0%	0.0%	0.0%	0.0%

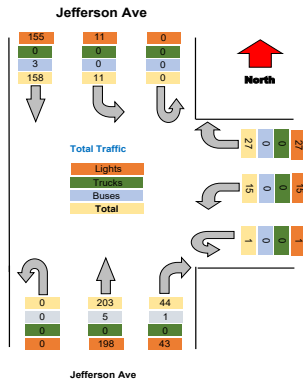

Brunswick Blvd

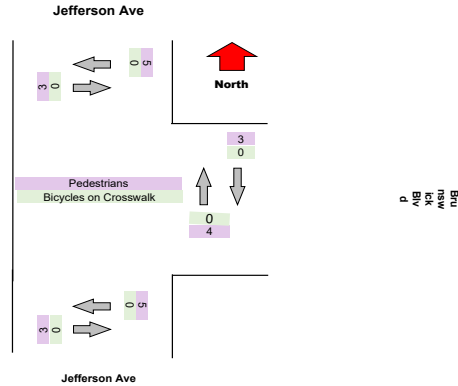

Brunswick Blvd

Project : VBH Malta NY
 Site : Site 4
 Location : 42.948550, -73.790036
 Survey Date : 2021-04-28, Wednesday

Turning Movement Data Plot

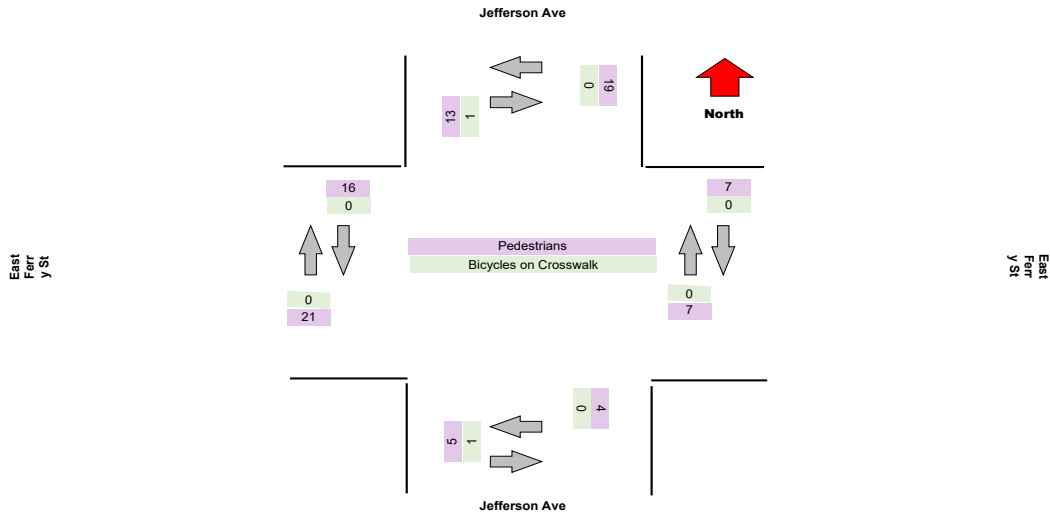
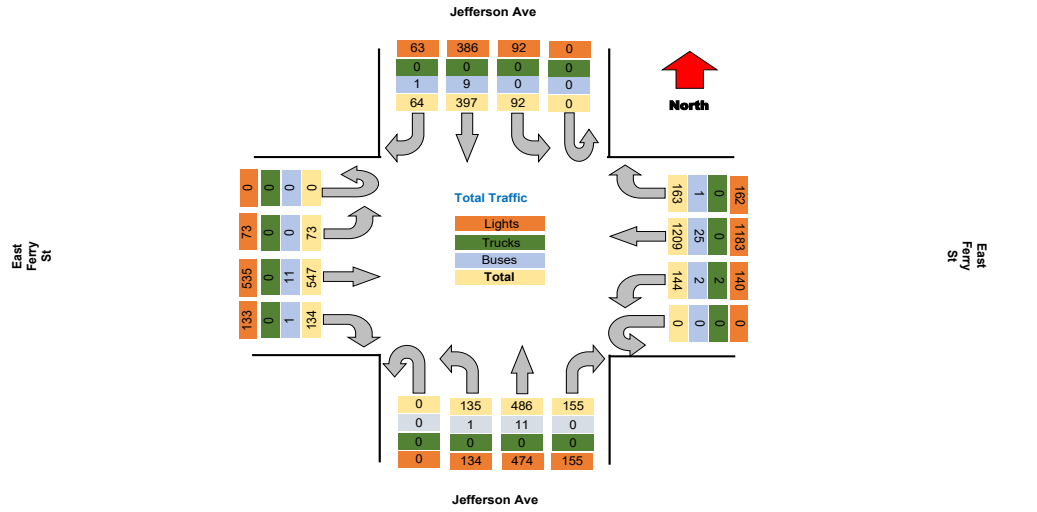

Turning Movement Peak Hour Data (AM)

7:30:00 AM

Leg Direction	Jefferson Ave					East Ferry St					Jefferson Ave					East Ferry St					Total									
	Right	Thru	Left	U-Turn	App Total	Peds CW	Peds CCW	Right	Thru	Left	U-Turn	App Total	Peds CW	Peds CCW	Right	Thru	Left	U-Turn	App Total	Peds CW		Peds CCW								
7:30:00 AM	1	14	5	0	20	1	0	6	64	3	0	73	2	0	5	18	5	0	30	1	1	6	24	1	0	31	1	1	154	
7:45:00 AM	5	15	3	0	23	1	2	9	104	10	0	125	0	1	2	22	4	0	29	1	1	3	33	3	0	39	0	2	216	
8:00:00 AM	2	18	3	0	23	3	5	7	90	5	0	107	0	1	5	17	2	0	25	0	0	2	29	2	0	33	1	1	188	
8:15:00 AM	2	30	3	0	35	1	1	9	70	7	0	87	0	1	6	9	7	0	23	0	1	7	27	0	0	34	3	1	179	
Grand Total	10	77	14	0	101	6	9	31	328	25	0	392	2	2	18	66	18	0	107	2	2	18	113	8	0	137	3	5	737	
% Approach	9.9%	76.2%	13.9%	0.0%	0.0%	0.0%	0.0%	7.9%	83.7%	6.4%	0.0%	0.0%	0.0%	0.0%	16.8%	61.7%	16.8%	0.0%	0.0%	0.0%	0.0%	13.1%	82.5%	4.4%	0.0%	0.0%	0.0%	0.0%	0.0%	
% Total	1.4%	10.4%	1.9%	0.0%	13.7%	0.0%	0.0%	4.2%	44.5%	3.4%	0.0%	53.2%	0.0%	0.0%	2.4%	9.0%	2.4%	0.0%	14.5%	0.0%	0.0%	2.4%	15.3%	0.8%	0.0%	18.6%	0.0%	0.0%	0.0%	
PHF	0.500	0.642	0.700	0.000	0.721	0.000	0.000	0.861	0.788	0.625	0.000	0.784	0.000	0.000	0.750	0.750	0.643	0.000	0.892	0.000	0.000	0.643	0.856	0.500	0.000	0.878	0.000	0.000	0.853	
Lights	10	74	14	0	98	0	9	31	321	24	0	376	0	0	18	62	18	0	98	0	0	18	110	6	0	134	0	0	706	
% Lights	100.0%	96.1%	100.0%	0.0%	97.0%	0.0%	0.0%	100.0%	97.9%	96.0%	0.0%	95.9%	0.0%	0.0%	100.0%	93.9%	100.0%	0.0%	91.6%	0.0%	0.0%	100.0%	97.3%	100.0%	0.0%	97.8%	0.0%	0.0%	95.8%	
Trucks	0	0	0	0	0	0	0	0	0	1	0	1	0	0	0	0	0	0	0	0	0	0	0	0	0	0	0	0	1	
% Trucks	0.0%	0.0%	0.0%	0.0%	0.0%	0.0%	0.0%	0.0%	0.0%	4.0%	0.0%	0.3%	0.0%	0.0%	0.0%	0.0%	0.0%	0.0%	0.0%	0.0%	0.0%	0.0%	0.0%	0.0%	0.0%	0.0%	0.0%	0.0%	0.1%	
Buses	0	2	0	0	2	0	0	0	6	0	0	6	0	0	0	4	0	0	4	0	0	0	3	0	0	3	0	0	15	
% Buses	0.0%	2.6%	0.0%	0.0%	0.0%	0.0%	0.0%	0.0%	1.8%	0.0%	0.0%	0.0%	0.0%	0.0%	0.0%	6.1%	0.0%	0.0%	0.0%	0.0%	0.0%	0.0%	2.7%	0.0%	0.0%	0.0%	0.0%	0.0%	2.0%	
Pedestrians	0	0	0	0	0	6	5	0	0	0	0	0	2	3	0	0	0	0	0	2	3	0	0	0	0	0	5	5	0	
% Pedestrians	0.0%	0.0%	0.0%	0.0%	0.0%	100.0%	100.0%	0.0%	0.0%	0.0%	0.0%	0.0%	100.0%	100.0%	0.0%	0.0%	0.0%	0.0%	0.0%	0.0%	100.0%	100.0%	0.0%	0.0%	0.0%	0.0%	0.0%	100.0%	100.0%	0.0%
Bicycles on Crosswalk	0	0	0	0	0	0	0	0	0	0	0	0	0	0	0	0	0	0	0	0	0	0	0	0	0	0	0	0	0	
% Bicycles on Crosswalk	0.0%	0.0%	0.0%	0.0%	0.0%	0.0%	0.0%	0.0%	0.0%	0.0%	0.0%	0.0%	0.0%	0.0%	0.0%	0.0%	0.0%	0.0%	0.0%	0.0%	0.0%	0.0%	0.0%	0.0%	0.0%	0.0%	0.0%	0.0%	0.0%	

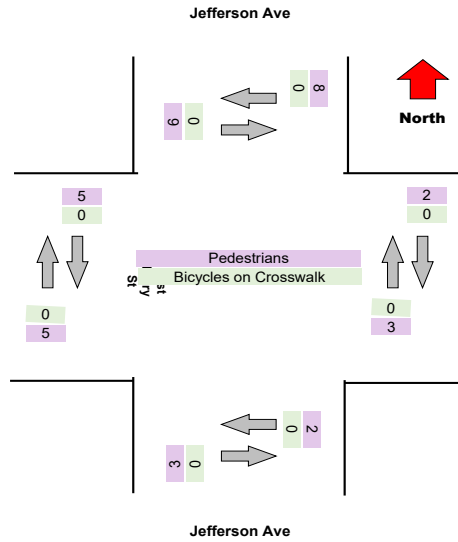
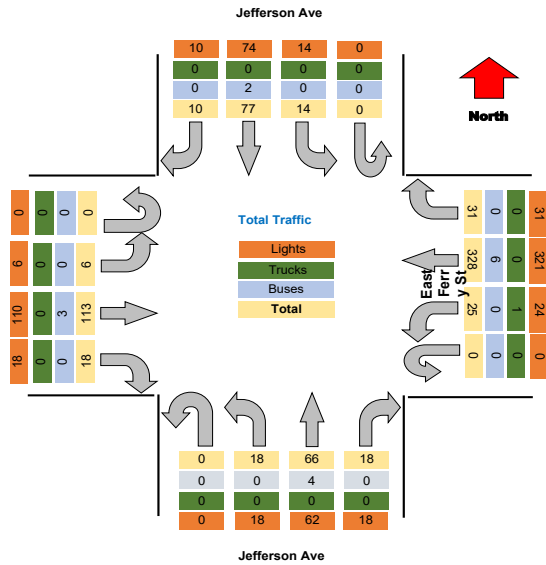

Turning Movement Peak Hour Data (PM)

4:15:00 PM

Leg Direction	Jefferson Ave					East Ferry St					Jefferson Ave					East Ferry St					Total									
	Southbound					Westbound					Northbound					Eastbound														
Start Time	Right	Thru	Left	U-Turn	App Total	Peds CW	Peds CCW	Right	Thru	Left	U-Turn	App Total	Peds CW	Peds CCW	Right	Thru	Left	U-Turn	App Total	Peds CW	Peds CCW	Right	Thru	Left	U-Turn	App Total	Peds CW	Peds CCW		
4:15:00 PM	5	33	5	0	43	3	1	10	93	13	0	116	2	1	16	47	13	0	76	0	0	12	47	9	0	68	3	1	303	
4:30:00 PM	6	46	6	0	58	1	0	13	85	9	0	107	1	0	22	46	13	0	81	1	0	18	47	7	0	72	2	1	318	
4:45:00 PM	3	35	7	0	45	3	3	5	97	13	0	115	1	1	8	43	13	0	64	0	0	7	50	12	0	69	2	1	293	
5:00:00 PM	11	31	11	0	53	0	0	17	75	9	0	102	1	0	15	43	8	0	66	0	0	18	45	11	0	74	0	1	298	
Grand Total	25	145	29	0	199	7	4	45	351	44	0	440	5	2	64	179	47	0	290	1	1	55	189	39	0	293	7	4	1212	
% Approach	12.6%	72.9%	14.6%	0.0%	0.0%	0.0%	0.0%	10.2%	79.8%	10.0%	0.0%	0.0%	0.0%	0.0%	22.1%	61.7%	16.2%	0.0%	0.0%	0.0%	0.0%	19.4%	66.8%	13.8%	0.0%	0.0%	0.0%	0.0%	0.0%	
% Total	2.1%	12.0%	2.4%	0.0%	16.4%	0.0%	0.0%	3.7%	29.0%	3.6%	0.0%	36.3%	0.0%	0.0%	5.3%	14.8%	3.9%	0.0%	23.9%	0.0%	0.0%	4.5%	15.6%	3.2%	0.0%	23.3%	0.0%	0.0%		
PHF	0.568	0.788	0.659	0.000	0.858	0.000	0.000	0.662	0.905	0.846	0.000	0.948	0.000	0.000	0.727	0.952	0.904	0.000	0.895	0.000	0.000	0.764	0.945	0.813	0.000	0.956	0.000	0.000	0.953	
Lights	25	141	29	0	195	0	0	45	346	43	0	434	0	0	64	176	46	0	286	0	0	54	186	39	0	279	0	0	1194	
% Lights	100.0%	97.2%	100.0%	0.0%	98.0%	0.0%	0.0%	100.0%	98.6%	97.7%	0.0%	98.6%	0.0%	0.0%	100.0%	98.3%	97.9%	0.0%	98.6%	0.0%	0.0%	98.2%	98.4%	100.0%	0.0%	98.6%	0.0%	0.0%	98.6%	
Trucks	0	0	0	0	0	0	0	0	0	1	0	1	0	0	0	0	0	0	0	0	0	0	0	0	0	0	0	0	1	
% Trucks	0.0%	0.0%	0.0%	0.0%	0.0%	0.0%	0.0%	0.0%	0.0%	2.3%	0.0%	0.2%	0.0%	0.0%	0.0%	0.0%	0.0%	0.0%	0.0%	0.0%	0.0%	0.0%	0.0%	0.0%	0.0%	0.0%	0.0%	0.0%	0.1%	
Buses	0	3	0	0	3	0	0	0	5	0	0	5	0	0	0	2	1	0	3	0	0	1	3	0	0	4	0	0	15	
% Buses	0.0%	2.1%	0.0%	0.0%	0.0%	0.0%	0.0%	0.0%	1.4%	0.0%	0.0%	0.0%	0.0%	0.0%	0.0%	1.1%	2.1%	0.0%	0.0%	0.0%	0.0%	1.8%	1.6%	0.0%	0.0%	0.0%	0.0%	0.0%	1.2%	
Pedestrians	0	0	0	0	0	7	4	0	0	0	0	0	5	3	0	0	0	0	1	0	0	0	0	0	0	0	7	4	0	
% Pedestrians	0.0%	0.0%	0.0%	0.0%	0.0%	100.0%	100.0%	0.0%	0.0%	0.0%	0.0%	0.0%	100.0%	100.0%	0.0%	0.0%	0.0%	0.0%	0.0%	0.0%	0.0%	0.0%	0.0%	0.0%	0.0%	0.0%	0.0%	100.0%	100.0%	0.0%
Bicycles on Crosswalk	0	0	0	0	0	0	0	0	0	0	0	0	0	0	0	0	0	0	0	0	1	0	0	0	0	0	0	0	0	
% Bicycles on Crosswalk	0.0%	0.0%	0.0%	0.0%	0.0%	0.0%	0.0%	0.0%	0.0%	0.0%	0.0%	0.0%	0.0%	0.0%	0.0%	0.0%	0.0%	0.0%	0.0%	0.0%	100.0%	0.0%	0.0%	0.0%	0.0%	0.0%	0.0%	0.0%	0.0%	0.0%

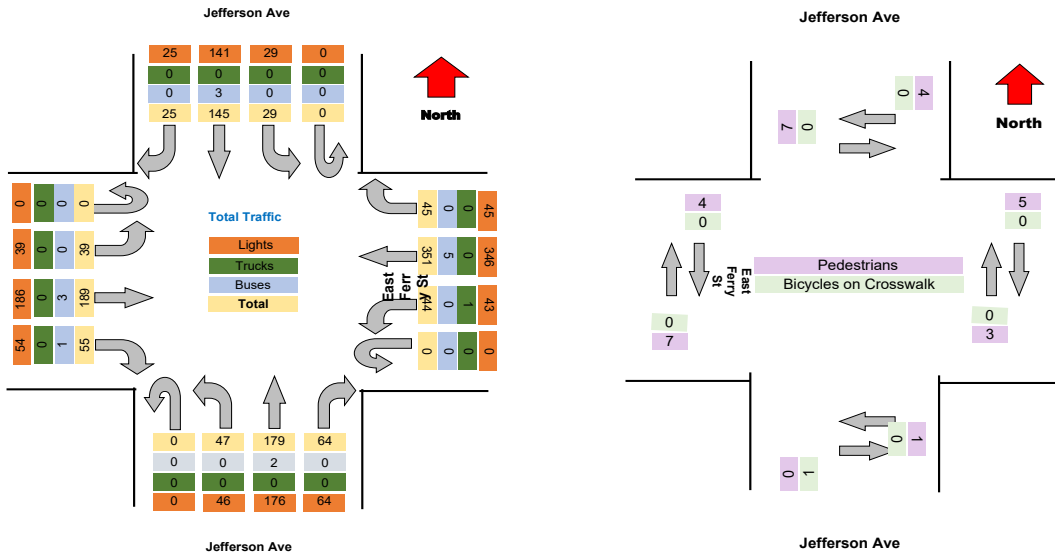

Project : VBH Malta NY
 Site : Site 4
 Location : 42.948550, -73.790036

TSTData.com

Survey Date : 2021-04-28, Wednesday

Project	LaBella
Project Code	LaBella
Site Name	32
Legs and Movements	All Processed Legs & Move
Bin Size	15 minutes
Survey Date	2021-11-03, Wednesday
Location	32
Latitude and Longitude	42.914969, -78.853981

	Start	End	PHF
Forced Peak AM	2021/11/03 07:30:00	2021/11/03 08:30:00	0.84
Forced Peak PM	2021/11/03 16:30:00	2021/11/03 17:30:00	0.96
AM Peak	2021/11/03 07:30:00	2021/11/03 08:30:00	0.84
PM Peak	2021/11/03 16:15:00	2021/11/03 17:15:00	0.95

Turning Movement Data

Leg Direction	Jefferson Ave							East Ferry St							Jefferson Ave							East Ferry St							Total				
	Southbound			Northbound				Westbound			Eastbound				Northbound			Eastbound															
Start Time	Right	Thru	Left	U-Turn	App Total	Peds CV	Peds CCV	Right	Thru	Left	U-Turn	App Total	Peds CV	Peds CCV	Right	Thru	Left	U-Turn	App Total	Peds CV	Peds CCV	Right	Thru	Left	U-Turn	App Total	Peds CV	Peds CCV					
6:30:00 AM	3	6	4	0	13	1	2	6	39	2	0	49	0	0	4	13	4	0	21	1	0	3	21	0	0	5	15	1	0	24	0	0	107
6:45:00 AM	2	18	1	0	21	0	0	6	58	1	0	63	0	0	3	5	4	0	12	0	0	5	15	1	0	21	1	0	21	1	0	117	
Hourly Total	5	24	5	0	34	1	2	12	95	3	0	112	0	0	7	18	8	0	33	1	0	8	36	1	0	45	1	0	45	1	0	224	
7:00:00 AM	2	14	3	0	19	1	3	4	59	4	0	70	0	0	5	28	2	0	35	3	0	6	28	3	0	35	2	4	159				
7:15:00 AM	5	15	1	0	21	1	1	5	74	8	0	86	0	0	5	22	7	0	34	0	0	11	30	5	0	46	2	0	167				
7:30:00 AM	5	18	4	0	27	0	1	6	106	11	0	124	1	0	6	24	4	0	35	3	0	8	49	4	0	61	1	0	247				
7:45:00 AM	5	46	6	0	57	1	0	9	132	13	0	154	0	0	5	17	7	0	29	1	0	14	53	6	0	73	0	0	313				
Hourly Total	17	93	14	0	124	3	5	24	371	34	0	434	1	0	21	91	20	0	133	7	0	39	158	18	0	215	5	4	906				
8:00:00 AM	4	25	3	0	32	1	3	11	109	10	0	133	1	4	3	33	13	0	54	1	0	14	45	7	0	66	0	2	285				
8:15:00 AM	6	24	4	0	34	0	0	10	65	8	0	83	1	0	7	25	9	0	42	0	0	4	41	8	0	53	1	0	212				
Hourly Total	10	49	7	0	66	1	3	21	174	18	0	216	2	4	10	58	22	0	96	1	0	18	86	15	0	119	1	2	497				
4:00:00 PM	4	40	9	0	53	1	0	14	86	10	0	110	0	0	12	59	11	0	82	3	1	16	67	8	0	91	3	1	336				
4:15:00 PM	9	37	9	0	55	0	1	18	92	15	0	125	0	1	18	50	17	0	85	0	0	9	58	6	0	73	1	0	338				
4:30:00 PM	6	60	14	0	80	1	2	14	83	11	0	108	2	2	17	38	13	0	68	0	1	12	53	5	0	70	0	0	326				
4:45:00 PM	4	33	10	0	47	0	3	13	94	6	0	113	0	1	15	43	14	0	72	1	1	12	61	3	0	66	3	2	298				
Hourly Total	23	170	42	0	235	2	6	59	355	42	0	456	2	4	62	190	55	0	397	4	3	49	229	22	0	390	7	3	1298				
5:00:00 PM	4	39	9	0	52	0	1	11	78	20	0	108	0	1	15	58	15	0	86	0	0	16	54	8	0	78	0	0	322				
5:15:00 PM	5	37	7	0	49	0	2	9	105	12	0	126	0	0	20	54	14	0	88	0	0	13	52	5	0	70	1	1	333				
5:30:00 PM	3	42	7	0	52	1	4	12	80	16	0	108	0	0	10	42	15	0	67	0	2	13	52	3	0	68	1	2	295				
5:45:00 PM	5	32	4	0	41	1	1	11	88	11	0	120	0	0	17	41	10	0	68	0	0	6	46	5	0	57	1	4	286				
Hourly Total	17	150	27	0	194	2	8	43	358	59	0	460	0	1	62	193	54	0	309	0	2	48	204	21	0	273	3	7	1236				
Grand Total	72	486	95	0	653	5	24	159	1353	156	0	1678	5	9	162	550	159	0	878	13	5	162	713	77	0	952	17	15	4181				
% Approach	11.0%	74.4%	14.5%	0.0%	0.0%	0.0%	0.0%	9.5%	80.6%	9.3%	0.0%	0.0%	0.0%	0.0%	18.5%	62.6%	18.1%	0.0%	0.0%	0.0%	0.0%	17.0%	74.9%	8.1%	0.0%	0.0%	0.0%	0.0%	0.0%				
% Total	1.7%	11.7%	2.3%	0.0%	15.7%	0.0%	0.0%	3.8%	32.5%	3.7%	0.0%	40.3%	0.0%	0.0%	3.9%	13.2%	3.8%	0.0%	21.1%	0.0%	0.0%	3.9%	17.1%	1.9%	0.0%	22.9%	0.0%	0.0%	0.0%				
Lights	66	471	91	0	628	0	0	147	1300	145	0	1592	0	0	158	526	154	0	838	0	0	153	667	71	0	891	0	0	3949				
% Lights	91.7%	96.9%	95.8%	0.0%	96.2%	0.0%	0.0%	92.5%	96.1%	92.9%	0.0%	94.9%	0.0%	0.0%	97.5%	95.6%	96.9%	0.0%	95.4%	0.0%	0.0%	94.4%	93.5%	92.2%	0.0%	93.6%	0.0%	0.0%	94.9%				
Trucks	0	1	0	0	1	0	0	0	0	0	0	0	0	0	0	0	0	0	0	0	0	0	1	0	0	1	0	0	2				
% Trucks	0.0%	0.2%	0.0%	0.0%	0.2%	0.0%	0.0%	0.0%	0.0%	0.0%	0.0%	0.0%	0.0%	0.0%	0.0%	0.0%	0.0%	0.0%	0.0%	0.0%	0.0%	0.0%	0.1%	0.0%	0.0%	0.1%	0.0%	0.0%	0.0%				
Buses	6	14	4	0	24	0	0	12	53	11	0	76	0	0	4	24	5	0	33	0	0	9	45	6	0	60	0	0	193				
% Buses	8.3%	2.9%	4.2%	0.0%	0.0%	0.0%	0.0%	0.0%	3.9%	7.1%	0.0%	0.0%	0.0%	0.0%	2.5%	4.4%	3.1%	0.0%	0.0%	0.0%	0.0%	5.6%	6.3%	7.8%	0.0%	0.0%	0.0%	0.0%	4.6%				
Pedestrians	0	0	0	0	0	9	23	0	0	0	0	5	8	0	0	0	0	0	13	5	0	0	0	0	17	12	0	29					
% Pedestrians	0.0%	0.0%	0.0%	0.0%	0.0%	100.0%	85.8%	0.0%	0.0%	0.0%	0.0%	100.0%	88.9%	0.0%	0.0%	0.0%	0.0%	100.0%	100.0%	100.0%	0.0%	0.0%	0.0%	0.0%	0.0%	100.0%	75.0%	0.0%					
Bicycles on Crosswalk	0	0	0	0	0	0	1	0	0	0	0	0	0	1	0	0	0	0	0	0	0	0	0	0	0	0	0	0	1				
% Bicycles on Crosswalk	0.0%	0.0%	0.0%	0.0%	0.0%	0.0%	4.2%	0.0%	0.0%	0.0%	0.0%	0.0%	0.0%	11.1%	0.0%	0.0%	0.0%	0.0%	0.0%	0.0%	0.0%	0.0%	0.0%	0.0%	0.0%	0.0%	0.0%	0.0%	0.0%				

Project : VBH Malta NY
 Site : Site 4
 Location : 42.948550, -73.790036
 Survey Date : 2021-04-28, Wednesday

Turning Movement Data Plot

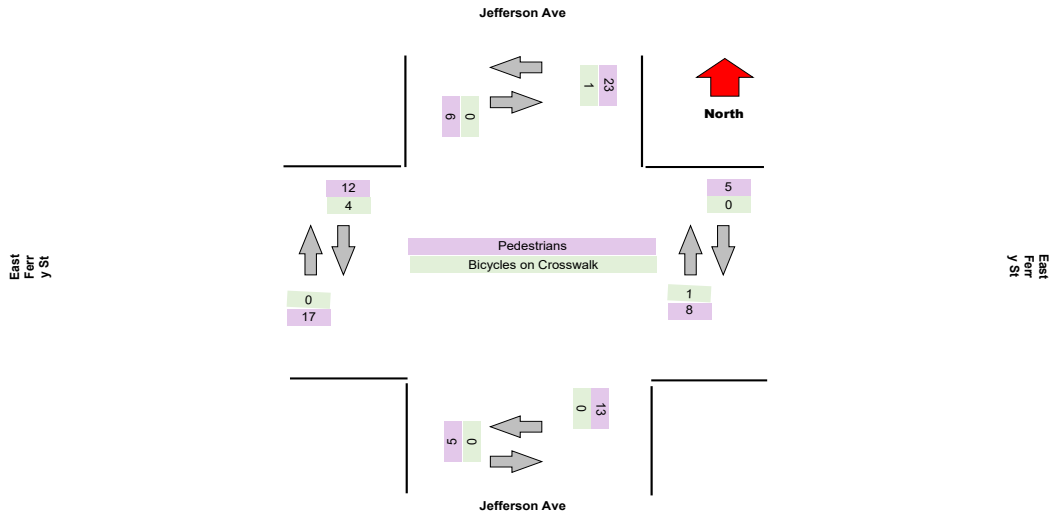
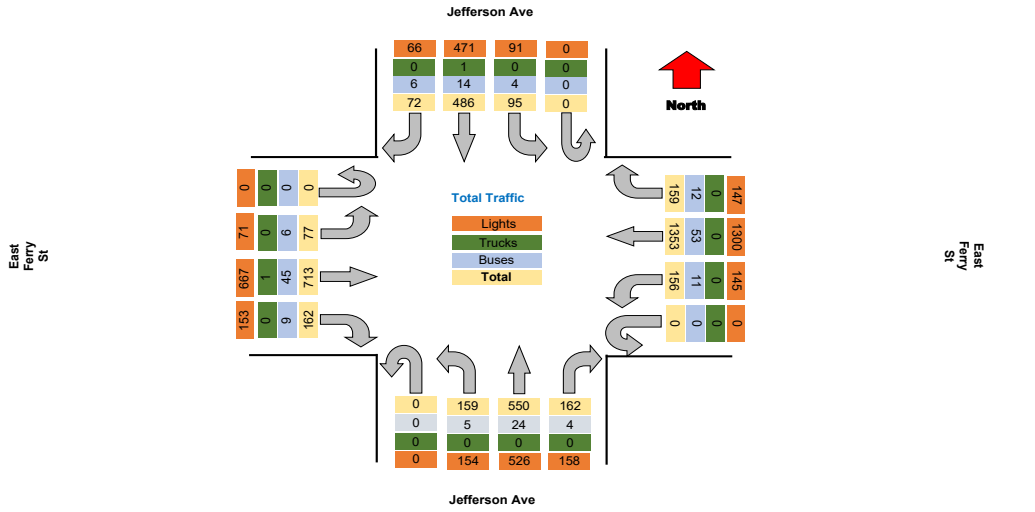

Project : VBH Malta NY
Site : Site 4
Location : 42.948550, -73.790036

TSTData.com

Survey Date : 2021-04-28, Wednesday

Turning Movement Peak Hour Data (AM)

7:30:00 AM

Leg Direction	Jefferson Ave					East Ferry St					Jefferson Ave					East Ferry St					Total	
	Southbound					Westbound					Northbound					Eastbound						
Start Time	Right	Thru	Left	U-Turn	App Total	Peds CW	Peds CCW	Right	Thru	Left	U-Turn	App Total	Peds CW	Peds CCW	Right	Thru	Left	U-Turn	App Total	Peds CW	Peds CCW	Total
7:30:00 AM	5	18	4	0	27	0	1	6	106	11	0	124	1	0	6	24	4	0	35	3	0	247
7:45:00 AM	5	46	6	0	57	1	0	9	132	13	0	154	0	0	5	17	7	0	29	1	0	313
8:00:00 AM	4	25	3	0	32	1	0	11	109	10	0	133	1	4	3	33	13	0	54	1	0	285
8:15:00 AM	6	24	4	0	34	0	0	10	65	8	0	83	1	0	7	25	9	0	42	0	0	212
Grand Total	20	113	17	0	150	2	1	36	412	42	0	494	3	4	21	99	33	0	160	5	0	1057
% Approach	13.3%	75.3%	11.3%	0.0%	0.0%	0.0%	0.0%	7.3%	83.4%	8.5%	0.0%	0.0%	0.0%	0.0%	13.1%	61.9%	20.6%	0.0%	0.0%	0.0%	0.0%	0.0%
% Total	1.9%	10.7%	1.6%	0.0%	14.2%	0.0%	0.0%	3.4%	39.0%	4.0%	0.0%	46.7%	0.0%	0.0%	2.0%	9.4%	3.1%	0.0%	15.1%	0.0%	0.0%	0.0%
PHF	0.833	0.614	0.708	0.000	0.658	0.000	0.000	0.818	0.780	0.808	0.000	0.802	0.000	0.000	0.750	0.750	0.635	0.000	0.741	0.000	0.000	0.844
Lights	18	110	15	0	143	0	0	33	395	37	0	465	0	0	18	91	31	0	140	0	0	976
% Lights	80.0%	97.3%	88.2%	0.0%	95.3%	0.0%	0.0%	81.7%	95.9%	88.1%	0.0%	94.1%	0.0%	0.0%	85.7%	91.0%	93.9%	0.0%	87.5%	0.0%	0.0%	92.3%
Trucks	0	0	0	0	0	0	0	0	0	0	0	0	0	0	0	0	0	0	0	0	0	0
% Trucks	0.0%	0.0%	0.0%	0.0%	0.0%	0.0%	0.0%	0.0%	0.0%	0.0%	0.0%	0.0%	0.0%	0.0%	0.0%	0.0%	0.0%	0.0%	0.0%	0.0%	0.0%	0.0%
Buses	2	3	2	0	7	0	0	3	17	5	0	25	0	0	3	8	2	0	13	0	0	69
% Buses	10.0%	2.7%	11.8%	0.0%	0.0%	0.0%	0.0%	8.3%	4.1%	11.9%	0.0%	0.0%	0.0%	0.0%	14.3%	8.1%	6.1%	0.0%	0.0%	0.0%	0.0%	6.5%
Pedestrians	0	0	0	0	0	2	4	0	0	0	0	3	4	0	0	0	0	0	0	5	0	0
% Pedestrians	0.0%	0.0%	0.0%	0.0%	0.0%	100.0%	100.0%	0.0%	0.0%	0.0%	0.0%	0.0%	100.0%	100.0%	0.0%	0.0%	0.0%	0.0%	0.0%	100.0%	0.0%	0.0%
Bicycles on Crosswalk	0	0	0	0	0	0	0	0	0	0	0	0	0	0	0	0	0	0	0	0	0	0
% Bicycles on Crosswalk	0.0%	0.0%	0.0%	0.0%	0.0%	0.0%	0.0%	0.0%	0.0%	0.0%	0.0%	0.0%	0.0%	0.0%	0.0%	0.0%	0.0%	0.0%	0.0%	0.0%	0.0%	0.0%

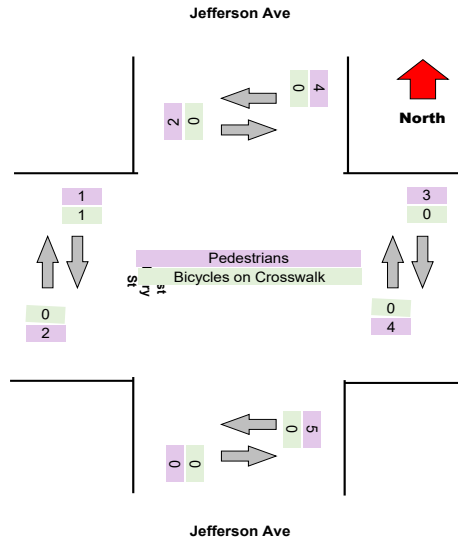
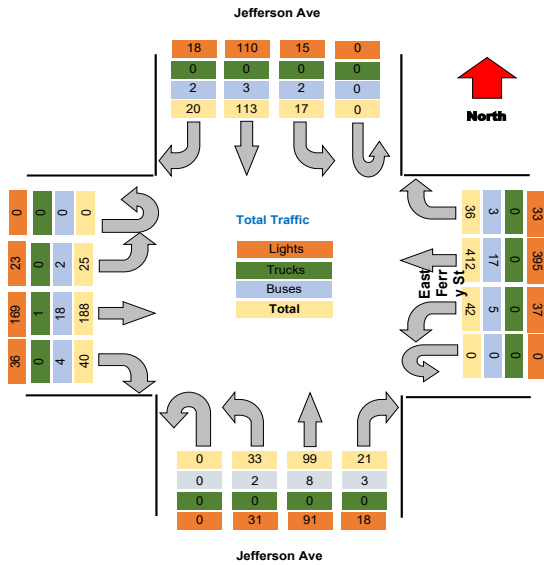

Turning Movement Peak Hour Data (PM)

4:15:00 PM

Leg Direction	Jefferson Ave				East Ferry St				Jefferson Ave				East Ferry St				Total					
	Southbound		Northbound		Westbound		Eastbound		Northbound		Southbound		Westbound									
Start Time	Right	Thru	Left	U-Turn	App Total	Peds CW	Peds CCW	Right	Thru	Left	U-Turn	App Total	Peds CW	Peds CCW	Right	Thru	Left	U-Turn	App Total	Peds CW	Peds CCW	
4:15:00 PM	9	37	9	0	55	0	1	18	92	15	0	125	0	1	18	50	17	0	85	0	0	338
4:30:00 PM	6	60	14	0	80	1	2	14	83	11	0	108	2	2	12	53	5	0	70	0	0	326
4:45:00 PM	4	33	10	0	47	0	3	13	94	6	0	113	0	1	15	43	14	0	72	1	1	298
5:00:00 PM	4	39	9	0	52	0	1	11	75	20	0	106	0	1	15	56	15	0	86	0	0	322
Grand Total	23	169	42	0	234	1	7	56	344	52	0	452	2	6	65	187	59	0	311	1	2	1284
% Approach	9.8%	72.2%	17.9%	0.0%	0.0%	0.0%	0.0%	12.4%	76.1%	11.5%	0.0%	0.0%	0.0%	0.0%	20.9%	60.1%	19.0%	0.0%	0.0%	0.0%	0.0%	0.0%
% Total	1.8%	13.2%	3.3%	0.0%	18.2%	0.0%	0.0%	4.4%	26.8%	4.0%	0.0%	35.2%	0.0%	0.0%	5.1%	14.6%	4.6%	0.0%	24.2%	0.0%	0.0%	0.0%
PHF	0.639	0.704	0.750	0.000	0.731	0.000	0.000	0.778	0.915	0.650	0.000	0.904	0.000	0.000	0.903	0.835	0.868	0.000	0.904	0.000	0.000	0.950
Lights	22	163	42	0	227	0	0	51	334	48	0	433	0	0	65	181	57	0	303	0	0	1238
% Lights	95.7%	96.4%	100.0%	0.0%	97.0%	0.0%	0.0%	91.1%	97.1%	92.3%	0.0%	95.8%	0.0%	0.0%	100.0%	96.8%	96.6%	0.0%	97.4%	0.0%	0.0%	96.4%
Trucks	0	0	0	0	0	0	0	0	0	0	0	0	0	0	0	0	0	0	0	0	0	0
% Trucks	0.0%	0.0%	0.0%	0.0%	0.0%	0.0%	0.0%	0.0%	0.0%	0.0%	0.0%	0.0%	0.0%	0.0%	0.0%	0.0%	0.0%	0.0%	0.0%	0.0%	0.0%	0.0%
Buses	1	6	0	0	7	0	0	5	10	4	0	19	0	0	0	6	2	0	8	0	0	46
% Buses	4.3%	3.6%	0.0%	0.0%	0.0%	0.0%	0.0%	8.9%	2.9%	7.7%	0.0%	0.0%	0.0%	0.0%	0.0%	3.2%	3.4%	0.0%	0.0%	0.0%	0.0%	3.6%
Pedestrians	0	0	0	0	0	1	6	0	0	0	0	0	2	4	0	0	0	0	0	1	2	0
% Pedestrians	0.0%	0.0%	0.0%	0.0%	0.0%	100.0%	85.7%	0.0%	0.0%	0.0%	0.0%	0.0%	100.0%	80.0%	0.0%	0.0%	0.0%	0.0%	0.0%	0.0%	100.0%	100.0%
Bicycles on Crosswalk	0	0	0	0	0	0	1	0	0	0	0	0	1	0	0	0	0	0	0	0	0	0
% Bicycles on Crosswalk	0.0%	0.0%	0.0%	0.0%	0.0%	0.0%	14.3%	0.0%	0.0%	0.0%	0.0%	0.0%	20.0%	0.0%	0.0%	0.0%	0.0%	0.0%	0.0%	0.0%	0.0%	0.0%

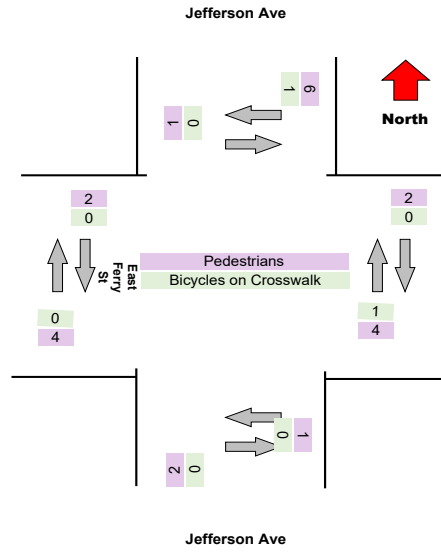
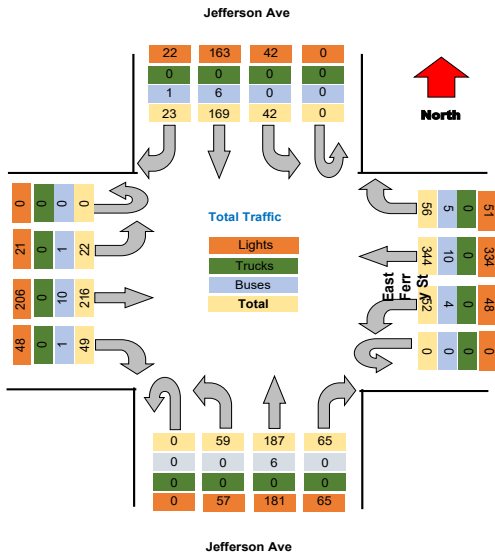

Turning Movement Data Plot

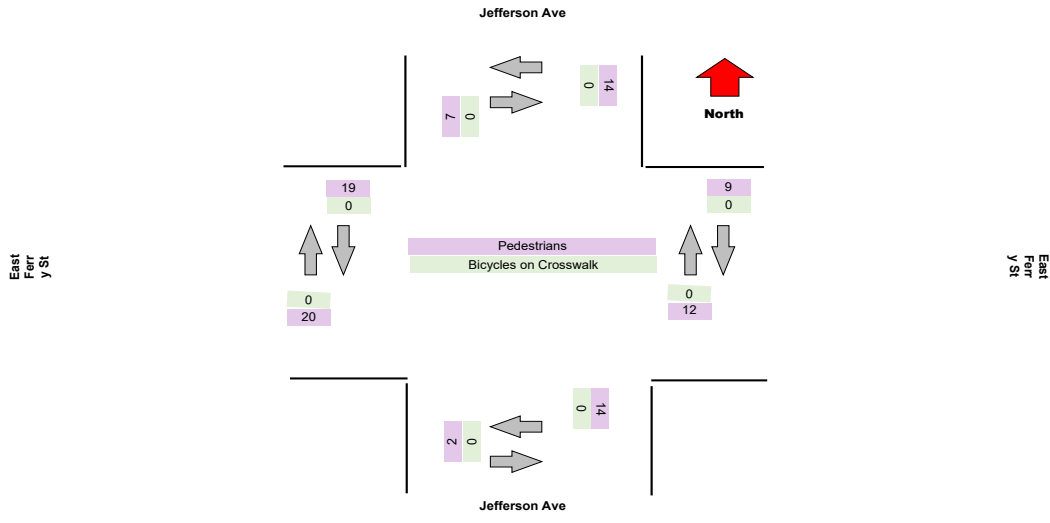
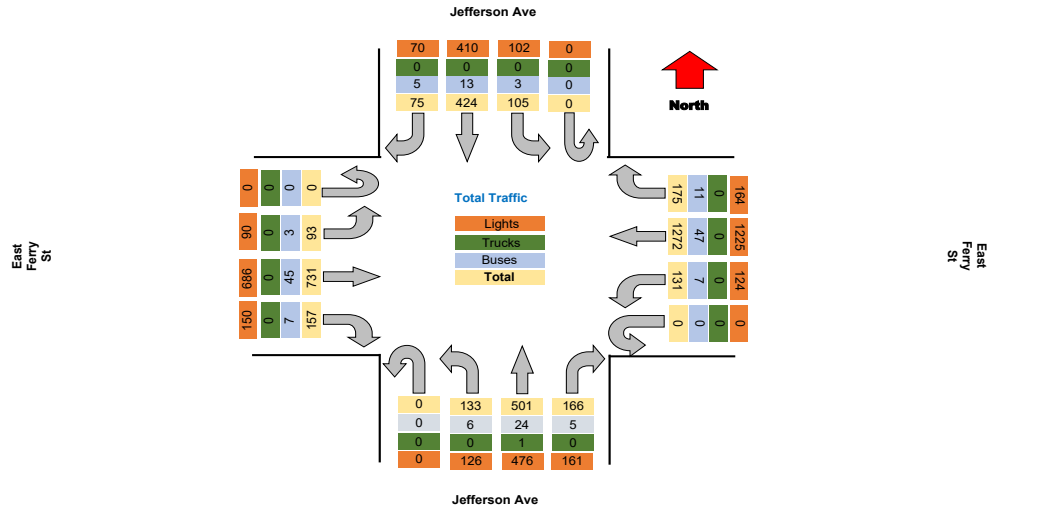

Project : VBH Malta NY
Site : Site 4
Location : 42.948550, -73.790036

TSTData.com

Survey Date : 2021-04-28, Wednesday

Turning Movement Peak Hour Data (AM)

7:30:00 AM

Leg Direction	Jefferson Ave					East Ferry St					Jefferson Ave					East Ferry St					Total	
	Southbound		Westbound			Northbound		Eastbound			Southbound		Westbound			Northbound		Eastbound				
Start Time	Right	Thru	Left	U-Turn	App Total	Peds CW	Peds CCW	Right	Thru	Left	U-Turn	App Total	Peds CW	Peds CCW	Right	Thru	Left	U-Turn	App Total	Peds CW	Peds CCW	Total
7:30:00 AM	7	19	6	0	32	0	2	5	105	7	0	119	0	1	6	14	6	0	27	4	1	241
7:45:00 AM	10	20	6	0	36	0	3	14	131	7	0	155	1	0	4	21	8	0	34	0	0	307
8:00:00 AM	5	31	7	0	43	0	0	19	102	6	0	129	0	3	10	27	9	0	49	1	1	288
8:15:00 AM	5	25	8	0	39	1	0	8	69	11	0	87	1	0	8	30	2	0	41	0	0	222
Grand Total	27	99	27	0	150	1	5	46	406	33	0	490	2	4	28	92	25	0	151	5	2	1088
% Approach	18.0%	64.0%	18.0%	0.0%	0.0%	0.0%	0.0%	9.4%	82.9%	6.7%	0.0%	0.0%	0.0%	0.0%	18.5%	60.9%	16.6%	0.0%	0.0%	0.0%	0.0%	0.0%
% Total	2.6%	9.1%	2.6%	0.0%	14.2%	0.0%	0.0%	4.3%	38.4%	3.1%	0.0%	46.3%	0.0%	0.0%	2.6%	8.7%	2.4%	0.0%	14.3%	0.0%	0.0%	0.0%
PHF	0.675	0.774	0.844	0.000	0.872	0.000	0.000	0.605	0.775	0.750	0.000	0.790	0.000	0.000	0.700	0.767	0.694	0.000	0.770	0.000	0.000	0.862
Lights	25	94	25	0	144	0	0	42	389	29	0	460	0	0	25	83	23	0	131	0	0	983
% Lights	92.6%	97.9%	92.6%	0.0%	96.0%	0.0%	0.0%	81.3%	95.8%	87.9%	0.0%	93.9%	0.0%	0.0%	89.3%	90.2%	92.0%	0.0%	86.8%	0.0%	0.0%	92.9%
Trucks	0	0	0	0	0	0	0	0	0	0	0	0	0	0	0	0	0	0	0	0	0	0
% Trucks	0.0%	0.0%	0.0%	0.0%	0.0%	0.0%	0.0%	0.0%	0.0%	0.0%	0.0%	0.0%	0.0%	0.0%	0.0%	0.0%	0.0%	0.0%	0.0%	0.0%	0.0%	0.0%
Buses	2	2	2	0	6	0	0	4	17	4	0	25	0	0	3	9	2	0	14	0	0	64
% Buses	7.4%	2.1%	7.4%	0.0%	0.0%	0.0%	0.0%	8.7%	4.2%	12.1%	0.0%	0.0%	0.0%	0.0%	10.7%	9.8%	8.0%	0.0%	0.0%	0.0%	0.0%	6.0%
Pedestrians	0	0	0	0	0	1	5	0	0	0	0	2	4	0	0	0	0	0	0	5	2	0
% Pedestrians	0.0%	0.0%	0.0%	0.0%	0.0%	100.0%	100.0%	0.0%	0.0%	0.0%	0.0%	0.0%	100.0%	100.0%	0.0%	0.0%	0.0%	0.0%	0.0%	100.0%	100.0%	0.0%
Bicycles on Crosswalk	0	0	0	0	0	0	0	0	0	0	0	0	0	0	0	0	0	0	0	0	0	0
% Bicycles on Crosswalk	0.0%	0.0%	0.0%	0.0%	0.0%	0.0%	0.0%	0.0%	0.0%	0.0%	0.0%	0.0%	0.0%	0.0%	0.0%	0.0%	0.0%	0.0%	0.0%	0.0%	0.0%	0.0%

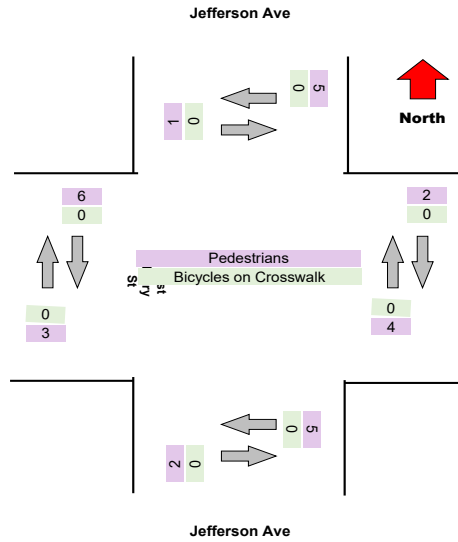
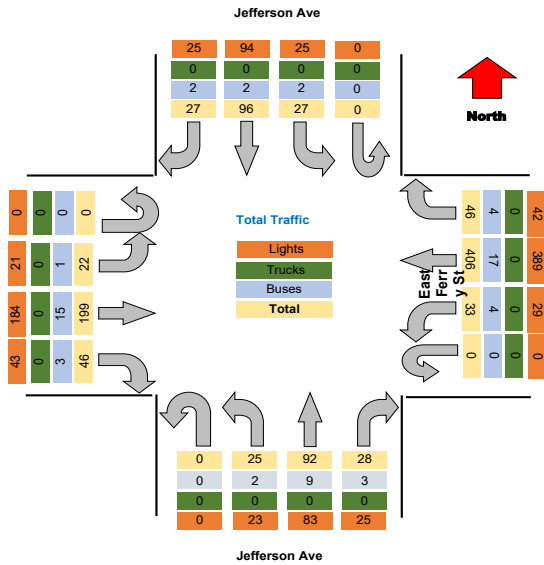

Turning Movement Peak Hour Data (PM)

4:15:00 PM

Leg Direction	Jefferson Ave					East Ferry St					Jefferson Ave					East Ferry St					Total					
	Southbound					Westbound					Northbound					Eastbound										
Start Time	Right	Thru	Left	U-Turn	App Total	Peds CW	Peds CCW	Right	Thru	Left	U-Turn	App Total	Peds CW	Peds CCW	Right	Thru	Left	U-Turn	App Total	Peds CW	Peds CCW	Total				
4:15:00 PM	6	36	11	0	53	0	0	14	81	11	0	106	0	1	19	54	15	0	88	0	0	77	1	0	324	
4:30:00 PM	4	36	7	0	47	0	1	9	93	10	0	112	2	1	15	39	7	0	61	1	0	99	1	4	319	
4:45:00 PM	6	35	8	0	49	1	3	14	86	15	0	115	1	2	20	40	13	0	73	0	0	73	1	0	310	
5:00:00 PM	8	41	8	0	57	0	0	19	82	8	0	109	0	1	15	54	6	0	75	2	0	80	6	0	321	
Grand Total	24	149	34	0	206	1	4	56	342	44	0	442	3	5	69	197	41	0	297	3	0	338	9	4	1274	
% Approach	11.7%	71.8%	16.5%	0.0%	0.0%	0.0%	0.0%	12.7%	77.4%	10.0%	0.0%	0.0%	0.0%	0.0%	23.2%	63.0%	13.8%	0.0%	0.0%	0.0%	0.0%	0.0%	0.0%	0.0%	0.0%	0.0%
% Total	1.9%	11.6%	2.7%	0.0%	16.2%	0.0%	0.0%	4.4%	26.8%	3.5%	0.0%	34.7%	0.0%	0.0%	5.4%	14.7%	3.2%	0.0%	23.3%	0.0%	0.0%	4.2%	16.8%	2.7%	0.0%	25.8%
PHF	0.750	0.902	0.773	0.000	0.904	0.000	0.000	0.737	0.919	0.733	0.000	0.961	0.000	0.000	0.863	0.866	0.683	0.000	0.844	0.000	0.000	0.794	0.789	0.875	0.000	0.831
Lights	21	144	34	0	199	0	0	51	333	42	0	426	0	0	68	182	38	0	288	0	0	53	228	34	0	315
% Lights	87.5%	97.3%	100.0%	0.0%	96.6%	0.0%	0.0%	81.1%	97.4%	95.5%	0.0%	96.4%	0.0%	0.0%	88.6%	97.3%	92.7%	0.0%	97.0%	0.0%	0.0%	98.1%	95.0%	97.1%	0.0%	95.7%
Trucks	0	0	0	0	0	0	0	0	0	0	0	0	0	0	0	0	0	0	0	0	0	0	0	0	0	0
% Trucks	0.0%	0.0%	0.0%	0.0%	0.0%	0.0%	0.0%	0.0%	0.0%	0.0%	0.0%	0.0%	0.0%	0.0%	0.0%	0.0%	0.0%	0.0%	0.0%	0.0%	0.0%	0.0%	0.0%	0.0%	0.0%	0.0%
Buses	3	4	0	0	7	0	0	5	9	2	0	16	0	0	1	5	3	0	9	0	0	1	12	1	0	14
% Buses	12.5%	2.7%	0.0%	0.0%	0.0%	0.0%	0.0%	8.9%	2.6%	4.5%	0.0%	0.0%	0.0%	0.0%	1.4%	2.7%	7.3%	0.0%	0.0%	0.0%	0.0%	1.9%	5.0%	2.9%	0.0%	0.0%
Pedestrians	0	0	0	0	0	1	4	0	0	0	0	3	5	0	0	0	0	0	3	0	0	0	0	0	0	9
% Pedestrians	0.0%	0.0%	0.0%	0.0%	0.0%	100.0%	100.0%	0.0%	0.0%	0.0%	0.0%	0.0%	100.0%	100.0%	0.0%	0.0%	0.0%	0.0%	0.0%	0.0%	0.0%	0.0%	0.0%	0.0%	0.0%	0.0%
Bicycles on Crosswalk	0	0	0	0	0	0	0	0	0	0	0	0	0	0	0	0	0	0	0	0	0	0	0	0	0	0
% Bicycles on Crosswalk	0.0%	0.0%	0.0%	0.0%	0.0%	0.0%	0.0%	0.0%	0.0%	0.0%	0.0%	0.0%	0.0%	0.0%	0.0%	0.0%	0.0%	0.0%	0.0%	0.0%	0.0%	0.0%	0.0%	0.0%	0.0%	0.0%

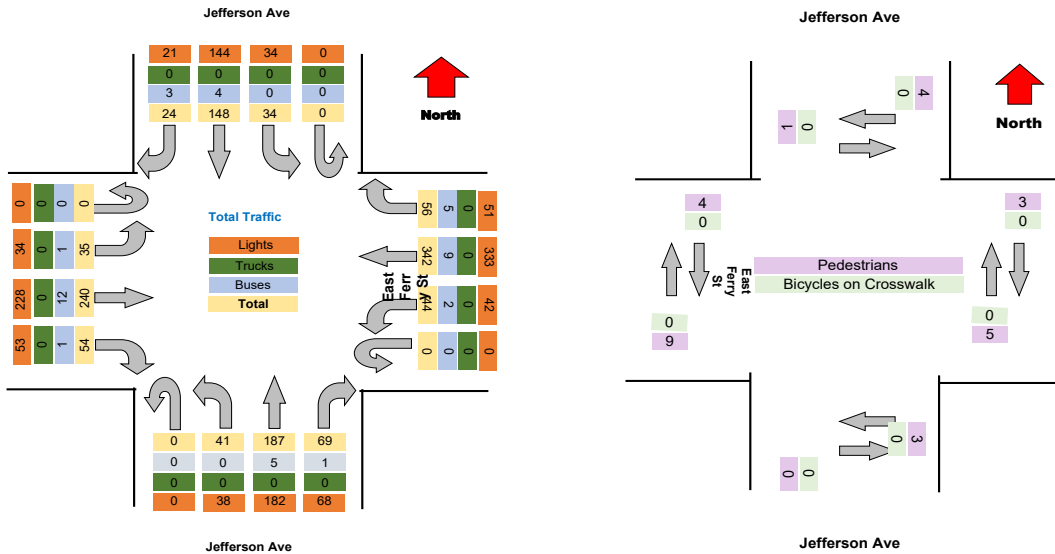

Project : VBH Malta NY
 Site : Site 4
 Location : 42.948550, -73.790036
 Survey Date : 2021-04-28, Wednesday

Turning Movement Data Plot

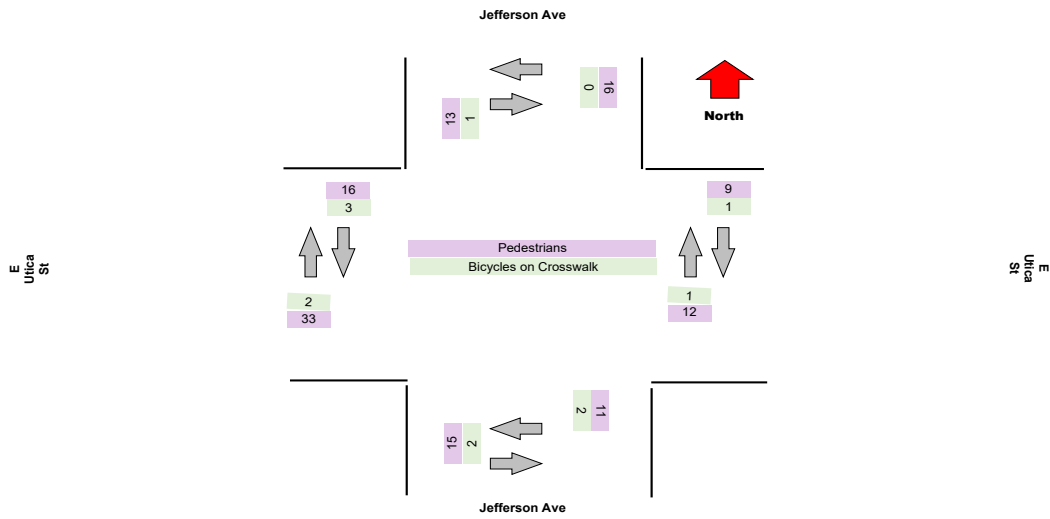
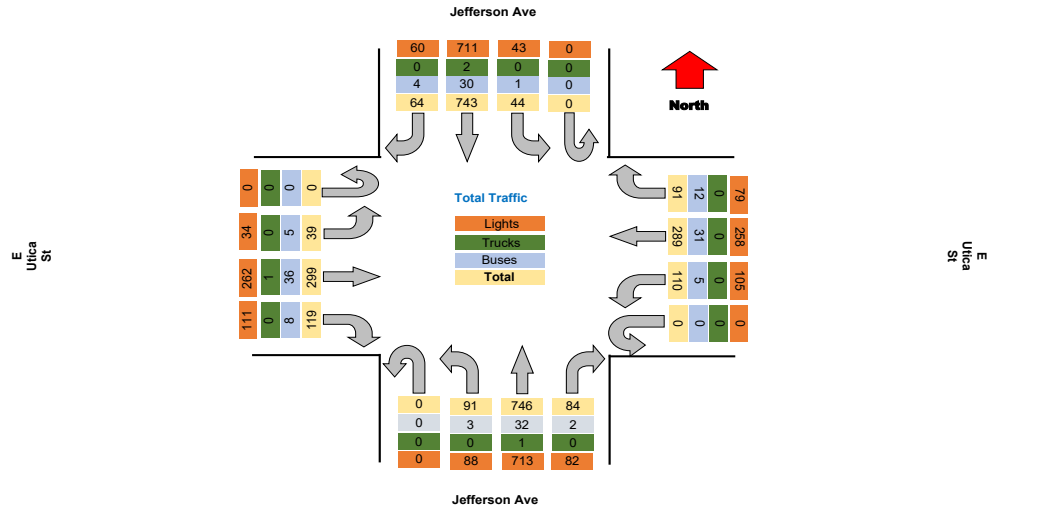

Project : VBH Malta NY
Site : Site 4
Location : 42.948550, -73.790036
Survey Date : 2021-04-28, Wednesday

TSTData.com

Turning Movement Peak Hour Data (AM)

7:30:00 AM

Leg Direction	Jefferson Ave					E Ulrica St					Jefferson Ave					E Ulrica St					Total									
	Right	Thru	Left	U-Turn	App Total	Peds CW	Peds CCW	Right	Thru	Left	U-Turn	App Total	Peds CW	Peds CCW	Right	Thru	Left	U-Turn	App Total	Peds CW		Peds CCW								
7:30:00 AM	5	28	1	0	34	0	1	4	17	4	0	26	1	0	2	27	2	0	32	1	1	5	15	2	0	22	2	1	114	
7:45:00 AM	6	67	4	0	77	0	1	1	31	4	0	37	0	1	3	25	5	0	34	1	0	5	20	1	0	26	2	0	174	
8:00:00 AM	3	47	2	0	52	1	1	5	24	7	0	37	1	0	1	40	7	0	49	1	0	10	25	2	0	37	5	3	175	
8:15:00 AM	4	30	1	0	35	1	0	1	17	5	0	25	1	0	3	39	5	0	49	2	0	11	23	3	0	37	4	0	146	
Grand Total	18	172	8	0	198	2	2	11	89	20	0	125	3	1	9	131	20	0	164	3	1	31	83	8	0	122	13	4	699	
% Approach	9.1%	86.9%	4.0%	0.0%	0.0%	0.0%	0.0%	8.8%	71.2%	16.0%	0.0%	0.0%	0.0%	0.0%	5.5%	79.9%	12.2%	0.0%	0.0%	0.0%	0.0%	25.4%	66.0%	6.6%	0.0%	0.0%	0.0%	0.0%	0.0%	
% Total	3.0%	28.2%	1.3%	0.0%	32.5%	0.0%	0.0%	1.8%	14.6%	3.3%	0.0%	20.5%	0.0%	0.0%	1.5%	21.5%	3.3%	0.0%	26.9%	0.0%	0.0%	5.1%	13.6%	1.3%	0.0%	20.0%	0.0%	0.0%	0.0%	
PHF	0.750	0.642	0.500	0.000	0.643	0.000	0.000	0.550	0.718	0.714	0.000	0.845	0.000	0.000	0.750	0.819	0.714	0.000	0.837	0.000	0.000	0.705	0.830	0.667	0.000	0.824	0.000	0.000	0.870	
Lights	17	164	7	0	188	0	0	9	79	17	0	105	0	0	8	119	18	0	145	0	0	28	68	8	0	104	0	0	542	
% Lights	84.4%	85.3%	87.5%	0.0%	94.9%	0.0%	0.0%	81.8%	88.8%	85.0%	0.0%	84.0%	0.0%	0.0%	88.9%	90.8%	90.0%	0.0%	88.4%	0.0%	0.0%	90.3%	81.9%	100.0%	0.0%	85.2%	0.0%	0.0%	89.0%	
Trucks	0	1	0	0	1	0	0	0	0	0	0	0	0	0	0	0	0	0	0	0	0	0	0	0	0	0	0	0	1	
% Trucks	0.0%	0.6%	0.0%	0.0%	0.5%	0.0%	0.0%	0.0%	0.0%	0.0%	0.0%	0.0%	0.0%	0.0%	0.0%	0.0%	0.0%	0.0%	0.0%	0.0%	0.0%	0.0%	0.0%	0.0%	0.0%	0.0%	0.0%	0.0%	0.2%	
Buses	1	7	1	0	9	0	0	2	10	3	0	15	0	0	1	12	2	0	15	0	0	3	15	0	0	18	0	0	57	
% Buses	5.6%	4.1%	12.5%	0.0%	0.0%	0.0%	0.0%	18.2%	11.2%	15.0%	0.0%	0.0%	0.0%	0.0%	11.1%	9.2%	10.0%	0.0%	0.0%	0.0%	0.0%	9.7%	18.1%	0.0%	0.0%	0.0%	0.0%	0.0%	9.4%	
Pedestrians	0	0	0	0	0	2	5	0	0	0	0	0	2	1	0	0	0	0	0	4	4	0	0	0	0	0	11	3	0	
% Pedestrians	0.0%	0.0%	0.0%	0.0%	0.0%	100.0%	100.0%	0.0%	0.0%	0.0%	0.0%	0.0%	66.7%	100.0%	0.0%	0.0%	0.0%	0.0%	0.0%	0.0%	80.0%	80.0%	0.0%	0.0%	0.0%	0.0%	0.0%	84.9%	75.0%	0.0%
Bicycles on Crosswalk	0	0	0	0	0	0	0	0	0	0	0	1	0	0	0	0	0	0	1	1	0	0	0	0	0	0	2	1	0	
% Bicycles on Crosswalk	0.0%	0.0%	0.0%	0.0%	0.0%	0.0%	0.0%	0.0%	0.0%	0.0%	0.0%	0.0%	33.3%	0.0%	0.0%	0.0%	0.0%	0.0%	0.0%	20.0%	20.0%	0.0%	0.0%	0.0%	0.0%	0.0%	15.4%	25.0%	0.0%	

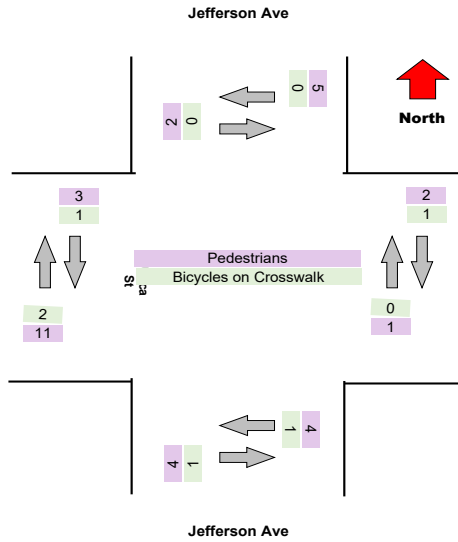
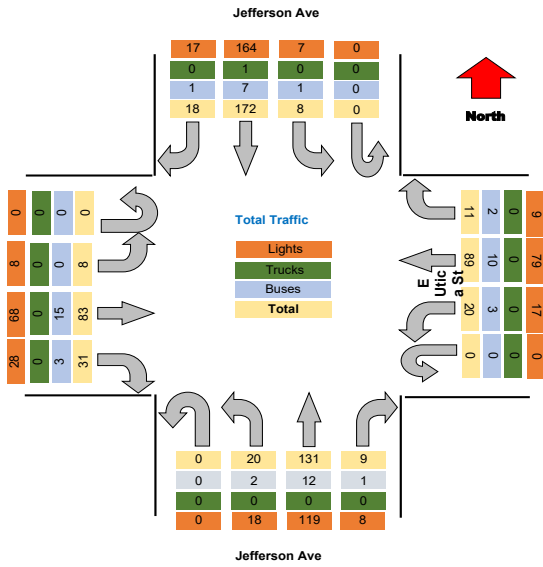

Turning Movement Peak Hour Data (PM)

4:15:00 PM

Leg Direction	Jefferson Ave				E Ulica St				Jefferson Ave				E Ulica St				Total													
	Southbound				Westbound				Northbound				Eastbound																	
	Right	Thru	Left	U-Turn	App Total	Peds CW	Peds CCW	Right	Thru	Left	U-Turn	App Total	Peds CW	Peds CCW	Right	Thru		Left	U-Turn	App Total	Peds CW	Peds CCW								
4:15:00 PM	4	62	2	0	68	0	2	8	24	11	0	43	0	1	13	69	10	0	92	2	3	6	20	3	0	29	4	2	232	
4:30:00 PM	4	84	4	0	92	0	0	6	27	9	0	42	0	0	6	64	6	0	76	0	1	11	23	1	0	35	1	2	246	
4:45:00 PM	4	47	3	0	54	2	2	7	17	12	0	36	0	4	7	61	10	0	78	2	1	8	19	4	0	31	5	1	199	
5:00:00 PM	7	64	6	0	77	1	0	9	21	12	0	42	0	0	8	73	9	0	90	1	0	9	24	3	0	36	0	0	245	
Grand Total	19	257	15	0	291	3	2	30	89	44	0	163	0	5	34	297	35	0	336	3	4	34	86	11	0	131	13	3	921	
% Approach	6.5%	88.3%	5.2%	0.0%	0.0%	0.0%	0.0%	18.4%	54.6%	27.0%	0.0%	0.0%	0.0%	0.0%	10.1%	79.5%	10.4%	0.0%	0.0%	0.0%	0.0%	26.0%	65.6%	8.4%	0.0%	0.0%	0.0%	0.0%	0.0%	
% Total	2.1%	27.9%	1.6%	0.0%	31.6%	0.0%	0.0%	3.3%	9.7%	4.8%	0.0%	17.7%	0.0%	0.0%	3.7%	29.0%	3.8%	0.0%	36.5%	0.0%	0.0%	3.7%	9.3%	1.2%	0.0%	14.2%	0.0%	0.0%	0.0%	
PHF	0.679	0.765	0.625	0.000	0.791	0.000	0.000	0.833	0.824	0.917	0.000	0.948	0.000	0.000	0.654	0.914	0.875	0.000	0.913	0.000	0.000	0.773	0.896	0.688	0.000	0.910	0.000	0.000	0.940	
Lights	19	246	15	0	280	0	0	24	80	43	0	147	0	0	34	261	34	0	329	0	0	32	78	11	0	121	0	0	877	
% Lights	100.0%	95.7%	100.0%	0.0%	96.2%	0.0%	0.0%	80.0%	89.9%	97.7%	0.0%	90.2%	0.0%	0.0%	100.0%	97.8%	97.1%	0.0%	97.9%	0.0%	0.0%	94.1%	90.7%	100.0%	0.0%	92.4%	0.0%	0.0%	95.2%	
Trucks	0	0	0	0	0	0	0	0	0	0	0	0	0	0	0	0	0	0	0	0	0	0	1	0	0	1	0	0	1	
% Trucks	0.0%	0.0%	0.0%	0.0%	0.0%	0.0%	0.0%	0.0%	0.0%	0.0%	0.0%	0.0%	0.0%	0.0%	0.0%	0.0%	0.0%	0.0%	0.0%	0.0%	0.0%	0.0%	1.2%	0.0%	0.0%	0.8%	0.0%	0.0%	0.1%	
Buses	0	11	0	0	11	0	0	6	9	1	0	16	0	0	0	6	1	0	7	0	0	2	7	0	0	9	0	0	43	
% Buses	0.0%	4.3%	0.0%	0.0%	0.0%	0.0%	0.0%	20.0%	10.1%	2.3%	0.0%	0.0%	0.0%	0.0%	0.0%	2.2%	2.9%	0.0%	0.0%	0.0%	0.0%	5.9%	8.1%	0.0%	0.0%	0.0%	0.0%	0.0%	4.7%	
Pedestrians	0	0	0	0	0	3	4	0	0	0	0	4	0	4	0	0	0	0	5	5	5	0	0	0	0	0	10	5	0	
% Pedestrians	0.0%	0.0%	0.0%	0.0%	0.0%	100.0%	100.0%	0.0%	0.0%	0.0%	0.0%	0.0%	0.0%	80.0%	0.0%	0.0%	0.0%	0.0%	0.0%	0.0%	0.0%	100.0%	100.0%	0.0%	0.0%	0.0%	0.0%	100.0%	100.0%	0.0%
Bicycles on Crosswalk	0	0	0	0	0	0	0	0	0	0	0	0	1	0	0	0	0	0	0	0	0	0	0	0	0	0	0	0	0	
% Bicycles on Crosswalk	0.0%	0.0%	0.0%	0.0%	0.0%	0.0%	0.0%	0.0%	0.0%	0.0%	0.0%	0.0%	0.0%	20.0%	0.0%	0.0%	0.0%	0.0%	0.0%	0.0%	0.0%	0.0%	0.0%	0.0%	0.0%	0.0%	0.0%	0.0%	0.0%	

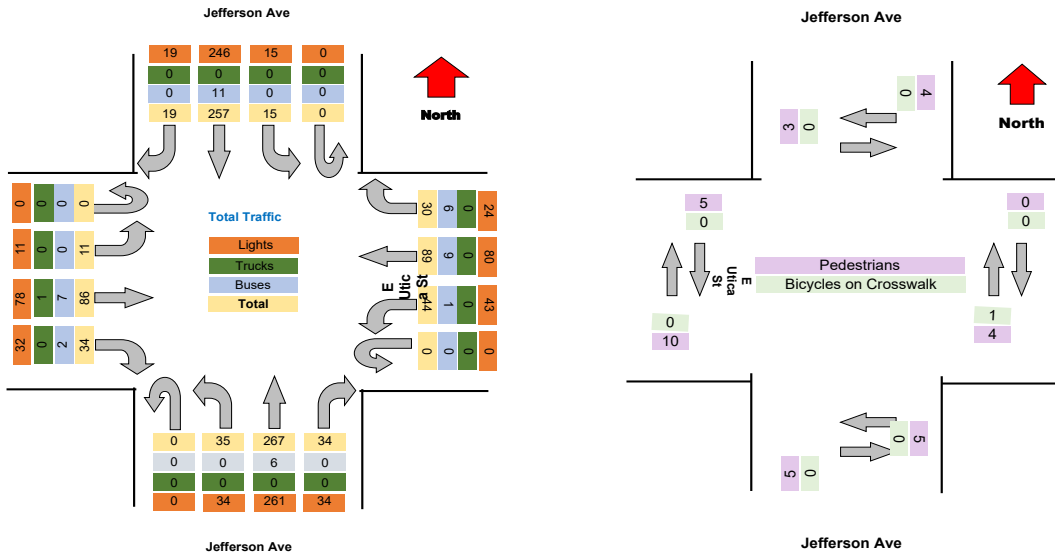

Project : VBH Malta NY
 Site : Site 4
 Location : 42.948550, -73.790036

TSTData.com

Survey Date : 2021-04-28, Wednesday

Project	LaBella
Project Code	LaBella
Site Name	33
Legs and Movements	All Processed Legs & Move
Bin Size	15 minutes
Survey Date	2021-11-04, Thursday
Location	33
Latitude and Longitude	42.911146, -78.853969

	Start	End	PHF
Forced Peak AM	2021/11/04 07:30:00	2021/11/04 08:30:00	0.89
Forced Peak PM	2021/11/04 16:30:00	2021/11/04 17:30:00	0.85
AM Peak	2021/11/04 07:30:00	2021/11/04 08:30:00	0.89
PM Peak	2021/11/04 16:15:00	2021/11/04 17:15:00	0.88

Turning Movement Data

Leg Direction	Jefferson Ave					E Utica St					Jefferson Ave					E Utica St					Total					
	Right	Thru	Left	U-Turn	App Total	Right	Thru	Left	U-Turn	App Total	Right	Thru	Left	U-Turn	App Total	Right	Thru	Left	U-Turn	App Total						
6:30:00 AM	1	11	0	0	12	0	7	1	0	8	1	5	0	0	6	2	4	2	0	8	1	0	0	0	1	45
6:45:00 AM	2	14	2	0	18	1	7	0	0	8	1	24	3	0	28	4	12	3	0	19	1	0	0	0	1	66
Hourly Total	3	25	2	0	30	1	14	1	0	17	2	29	3	0	34	6	16	5	0	27	2	0	0	0	2	111
7:00:00 AM	2	9	0	0	11	3	12	5	0	20	4	20	7	0	31	2	11	3	0	16	3	1	0	0	4	80
7:15:00 AM	3	24	1	0	28	2	22	5	0	29	2	29	5	0	36	2	9	8	2	19	6	0	0	0	6	112
7:30:00 AM	6	34	0	0	40	2	27	4	0	33	0	21	5	0	27	0	3	18	2	23	2	0	0	0	2	123
7:45:00 AM	5	35	5	0	45	2	28	7	0	37	1	5	34	4	44	0	5	16	2	23	0	1	0	0	1	150
Hourly Total	16	102	6	0	124	9	89	21	0	120	7	12	104	21	140	3	19	53	9	81	11	2	0	0	14	465
8:00:00 AM	6	41	2	0	49	3	20	6	0	30	2	6	39	4	51	2	7	19	4	30	6	5	0	0	11	162
8:15:00 AM	1	40	0	0	41	2	15	2	0	20	1	1	41	6	50	0	9	14	5	28	4	2	0	0	6	139
Hourly Total	7	81	2	0	90	5	35	8	0	50	3	7	80	10	103	2	16	33	9	58	10	7	0	0	17	301
4:00:00 PM	1	60	5	0	66	13	18	10	0	41	3	11	60	8	79	2	10	24	3	37	5	4	0	0	9	223
4:15:00 PM	3	69	3	0	75	6	25	10	0	41	4	9	60	12	81	0	6	24	8	38	7	4	0	0	11	235
4:30:00 PM	2	51	3	0	56	6	15	10	0	31	1	0	12	49	61	0	7	26	3	36	2	8	0	0	10	194
4:45:00 PM	10	59	1	0	70	13	25	13	0	51	0	16	68	9	83	1	10	26	6	42	3	2	0	0	5	256
Hourly Total	16	239	12	0	267	38	63	43	0	144	8	25	148	39	192	3	33	100	20	153	17	18	0	0	35	308
5:00:00 PM	9	67	5	0	71	9	27	8	0	44	2	3	60	9	72	1	4	21	7	32	4	1	0	0	5	219
5:15:00 PM	4	54	0	0	58	8	19	10	0	37	0	2	8	53	61	0	9	24	2	35	2	2	0	0	4	206
5:30:00 PM	4	60	1	0	65	10	15	11	0	36	0	1	5	52	57	0	14	19	4	37	0	0	0	0	14	202
5:45:00 PM	4	50	2	0	56	10	25	7	0	42	0	6	51	7	64	0	5	17	0	22	1	1	0	0	2	184
Hourly Total	21	221	8	0	250	37	86	36	0	159	2	22	216	38	276	1	32	81	13	126	7	4	0	0	11	611
Grand Total	63	668	30	0	761	90	307	109	0	510	14	90	672	116	888	14	104	279	54	437	46	21	0	0	67	2596
% Approach	8.3%	87.8%	3.9%	0.0%	0.0%	17.6%	60.2%	21.4%	0.0%	0.0%	10.1%	75.7%	13.1%	0.0%	0.0%	23.8%	63.8%	12.4%	0.0%	0.0%	0.0%	0.0%	0.0%	0.0%	0.0%	0.0%
% Total	2.4%	25.7%	1.2%	0.0%	29.3%	3.5%	11.8%	4.2%	0.0%	19.6%	3.5%	25.9%	4.5%	0.0%	34.2%	4.0%	10.7%	2.1%	0.0%	16.8%	0.0%	0.0%	0.0%	0.0%	0.0%	0.0%
Lights	60	639	29	0	728	81	277	105	0	463	0	82	639	112	833	0	97	249	50	396	0	0	0	0	0	2420
% Lights	95.2%	95.7%	96.7%	0.0%	95.7%	90.9%	90.2%	96.3%	0.0%	90.6%	0.0%	81.1%	95.1%	96.6%	93.8%	0.0%	93.3%	89.2%	92.6%	90.6%	0.0%	0.0%	0.0%	0.0%	0.0%	93.2%
Trucks	0	0	0	0	0	0	0	0	0	0	0	3	0	0	3	0	0	0	0	0	0	0	0	0	0	3
% Trucks	0.0%	0.0%	0.0%	0.0%	0.0%	0.0%	0.0%	0.0%	0.0%	0.0%	0.0%	0.4%	0.0%	0.0%	0.3%	0.0%	0.0%	0.0%	0.0%	0.0%	0.0%	0.0%	0.0%	0.0%	0.0%	0.1%
Buses	3	28	1	0	32	9	30	4	0	43	0	8	28	4	40	0	7	30	4	41	0	0	0	0	0	156
% Buses	4.8%	4.2%	3.3%	0.0%	0.0%	0.0%	9.8%	3.7%	0.0%	0.0%	0.0%	8.9%	4.2%	3.4%	0.0%	0.0%	6.7%	10.8%	7.4%	0.0%	0.0%	0.0%	0.0%	0.0%	0.0%	6.0%
Pedestrians	0	0	0	0	0	0	0	0	0	0	13	0	0	0	13	0	0	0	0	0	45	31	0	0	0	76
% Pedestrians	0.0%	0.0%	0.0%	0.0%	0.0%	0.0%	0.0%	0.0%	0.0%	0.0%	82.8%	100.0%	0.0%	0.0%	0.0%	88.9%	100.0%	0.0%	0.0%	0.0%	87.8%	100.0%	0.0%	0.0%	0.0%	100.0%
Bicycles on Crosswalk	0	0	0	0	0	0	0	0	0	0	1	0	0	0	1	0	0	0	0	0	1	0	0	0	0	2
% Bicycles on Crosswalk	0.0%	0.0%	0.0%	0.0%	0.0%	0.0%	0.0%	0.0%	0.0%	0.0%	7.1%	0.0%	0.0%	0.0%	0.0%	11.1%	0.0%	0.0%	0.0%	0.0%	2.2%	0.0%	0.0%	0.0%	0.0%	0.0%

Project : VBH Malta NY
 Site : Site 4
 Location : 42.948550, -73.790036
 Survey Date : 2021-04-28, Wednesday

Turning Movement Data Plot

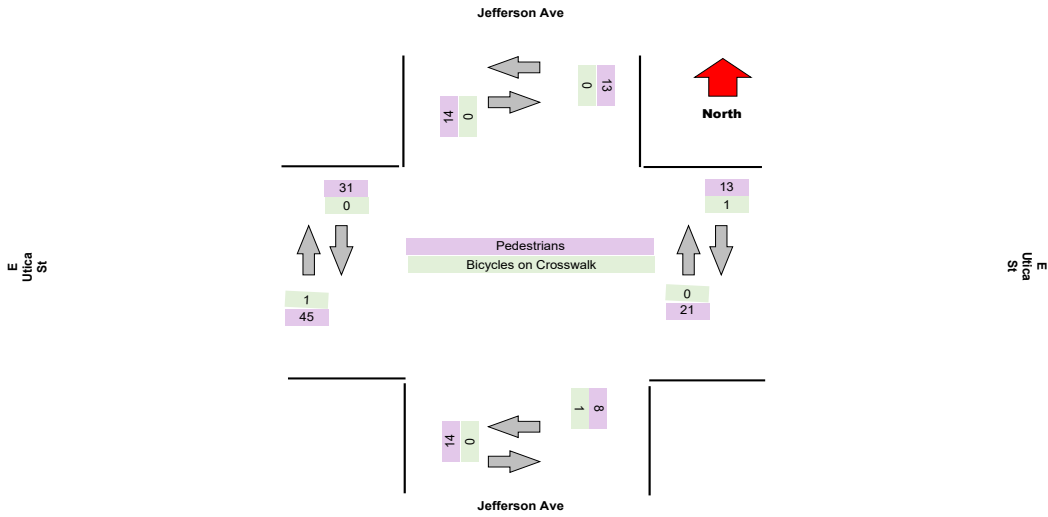
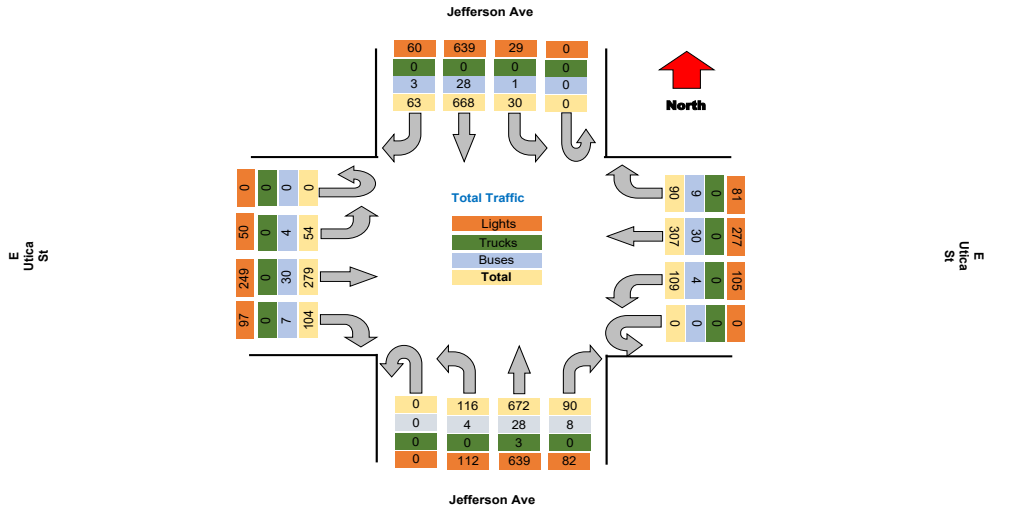

Project : VBH Malta NY
Site : Site 4
Location : 42.948550, -73.790036

TSTData.com

Survey Date : 2021-04-28, Wednesday

Turning Movement Peak Hour Data (AM)

7:30:00 AM

Leg Direction	Jefferson Ave					E Ulrica St					Jefferson Ave					E Ulrica St					Total									
	Southbound					Westbound					Northbound					Eastbound														
Start Time	Right	Thru	Left	U-Turn	App Total	Peds CW	Peds CCW	Right	Thru	Left	U-Turn	App Total	Peds CW	Peds CCW	Right	Thru	Left	U-Turn	App Total	Peds CW	Peds CCW	Total								
7:30:00 AM	6	34	0	0	40	0	0	2	27	4	0	33	0	0	1	21	5	0	27	0	0	23	2	0	123					
7:45:00 AM	5	35	5	0	45	1	1	2	28	7	0	38	0	1	5	34	4	0	44	0	1	5	16	2	0	23	0	1	160	
8:00:00 AM	6	41	2	0	49	0	1	3	20	6	0	30	2	2	6	39	4	0	53	2	1	7	19	4	0	30	6	5	162	
8:15:00 AM	1	40	0	0	41	1	1	2	15	2	0	20	1	1	1	41	6	0	50	0	0	9	14	5	0	28	4	2	139	
Grand Total	18	150	7	0	175	2	3	9	90	19	0	121	3	4	13	135	19	0	174	2	2	24	67	13	0	104	12	8	674	
% Approach	10.3%	85.7%	4.0%	0.0%	0.0%	0.0%	0.0%	7.4%	74.4%	15.7%	0.0%	0.0%	0.0%	0.0%	7.5%	77.6%	10.9%	0.0%	0.0%	0.0%	0.0%	23.1%	64.4%	12.5%	0.0%	0.0%	0.0%	0.0%	0.0%	
% Total	3.1%	26.1%	1.2%	0.0%	30.6%	0.0%	0.0%	1.6%	15.7%	3.3%	0.0%	21.1%	0.0%	0.0%	2.3%	23.5%	3.3%	0.0%	30.3%	0.0%	0.0%	4.2%	11.7%	2.3%	0.0%	18.1%	0.0%	0.0%	0.0%	
PHF	0.750	0.915	0.350	0.000	0.893	0.000	0.000	0.750	0.804	0.679	0.000	0.796	0.000	0.000	0.542	0.823	0.792	0.000	0.821	0.000	0.000	0.667	0.882	0.650	0.000	0.867	0.000	0.000	0.886	
Lights	17	144	6	0	167	0	0	7	80	17	0	104	0	0	9	121	18	0	148	0	0	22	54	13	0	89	0	0	508	
% Lights	84.4%	96.0%	85.7%	0.0%	95.4%	0.0%	0.0%	77.8%	88.9%	89.5%	0.0%	86.0%	0.0%	0.0%	69.2%	89.6%	94.7%	0.0%	85.1%	0.0%	0.0%	91.7%	80.6%	100.0%	0.0%	85.6%	0.0%	0.0%	88.6%	
Trucks	0	0	0	0	0	0	0	0	0	0	0	0	0	0	0	2	0	0	2	0	0	0	0	0	0	0	0	0	2	
% Trucks	0.0%	0.0%	0.0%	0.0%	0.0%	0.0%	0.0%	0.0%	0.0%	0.0%	0.0%	0.0%	0.0%	0.0%	0.0%	1.5%	0.0%	0.0%	1.1%	0.0%	0.0%	0.0%	0.0%	0.0%	0.0%	0.0%	0.0%	0.0%	0.3%	
Buses	1	6	1	0	8	0	0	2	10	2	0	14	0	0	4	12	1	0	17	0	0	2	13	0	0	15	0	0	54	
% Buses	5.6%	4.0%	14.3%	0.0%	0.0%	0.0%	0.0%	22.2%	11.1%	10.5%	0.0%	0.0%	0.0%	0.0%	30.8%	8.9%	5.3%	0.0%	0.0%	0.0%	0.0%	8.3%	19.4%	0.0%	0.0%	0.0%	0.0%	0.0%	9.4%	
Pedestrians	0	0	0	0	0	2	3	0	0	0	0	3	4	0	0	0	0	0	0	2	2	0	0	0	0	0	0	11	8	0
% Pedestrians	0.0%	0.0%	0.0%	0.0%	0.0%	100.0%	100.0%	0.0%	0.0%	0.0%	0.0%	0.0%	100.0%	100.0%	0.0%	0.0%	0.0%	0.0%	0.0%	0.0%	100.0%	100.0%	0.0%	0.0%	0.0%	0.0%	0.0%	91.7%	100.0%	0.0%
Bicycles on Crosswalk	0	0	0	0	0	0	0	0	0	0	0	0	0	0	0	0	0	0	0	0	0	0	0	0	0	0	0	1	0	0
% Bicycles on Crosswalk	0.0%	0.0%	0.0%	0.0%	0.0%	0.0%	0.0%	0.0%	0.0%	0.0%	0.0%	0.0%	0.0%	0.0%	0.0%	0.0%	0.0%	0.0%	0.0%	0.0%	0.0%	0.0%	0.0%	0.0%	0.0%	0.0%	0.0%	8.3%	0.0%	0.0%

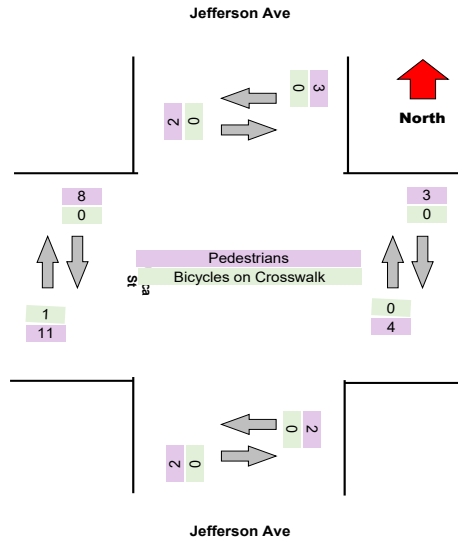
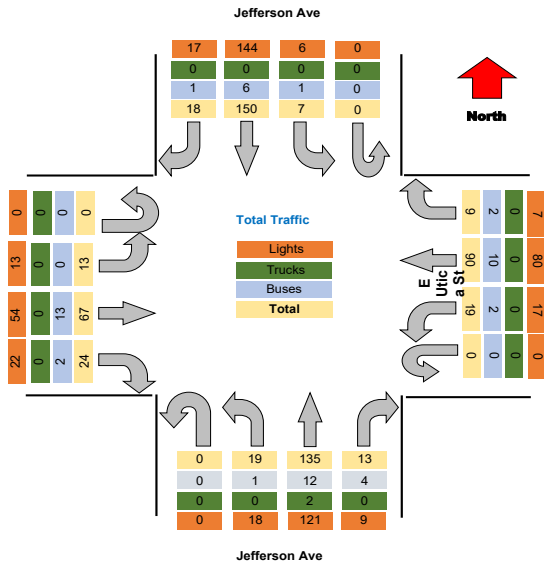

Turning Movement Peak Hour Data (PM)

4:15:00 PM

Leg Direction	Jefferson Ave								E Ulica St								Jefferson Ave								E Ulica St								Total
	Southbound				Westbound				Northbound				Eastbound				Southbound				Westbound				Northbound				Eastbound				
	Right	Thru	Left	U-Turn	App Total	Peds CW	Peds CCW		Right	Thru	Left	U-Turn	App Total	Peds CW	Peds CCW		Right	Thru	Left	U-Turn	App Total	Peds CW	Peds CCW		Right	Thru	Left	U-Turn	App Total	Peds CW	Peds CCW		
4:15:00 PM	3	69	3	0	75	4	1		6	25	10	0	41	4	3		9	60	12	0	81	0	1		6	24	8	0	38	7	4		235
4:30:00 PM	2	51	3	0	56	0	1		6	15	10	0	31	1	0		12	49	10	0	71	0	3		7	26	3	0	36	2	8		194
4:45:00 PM	10	59	1	0	70	4	2		13	25	13	0	51	0	4		16	68	9	0	93	1	0		10	26	6	0	42	3	2		256
5:00:00 PM	9	57	5	0	71	4	1		9	27	8	0	44	2	1		3	50	8	0	72	1	1		4	21	7	0	32	4	1		219
Grand Total	24	236	12	0	272	8	5		34	92	41	0	157	7	8		40	237	40	0	317	2	5		27	87	24	0	148	15	15		904
% Approach	8.8%	86.8%	4.4%	0.0%	0.0%	0.0%	0.0%		20.4%	55.1%	24.6%	0.0%	0.0%	0.0%	0.0%		12.6%	74.8%	12.6%	0.0%	0.0%	0.0%	0.0%		18.2%	65.5%	16.2%	0.0%	0.0%	0.0%	0.0%		
% Total	2.7%	26.1%	1.3%	0.0%	30.1%	0.0%	0.0%		3.8%	10.2%	4.5%	0.0%	18.5%	0.0%	0.0%		4.4%	26.2%	4.4%	0.0%	35.1%	0.0%	0.0%		3.0%	10.7%	2.7%	0.0%	16.4%	0.0%	0.0%		
PHF	0.600	0.855	0.600	0.000	0.907	0.000	0.000		0.654	0.852	0.788	0.000	0.819	0.000	0.000		0.625	0.871	0.833	0.000	0.852	0.000	0.000		0.675	0.933	0.750	0.000	0.881	0.000	0.000		0.883
Lights	24	226	12	0	262	0	0		29	83	41	0	153	0	0		39	229	38	0	306	0	0		26	93	24	0	143	0	0		864
% Lights	100.0%	95.8%	100.0%	0.0%	96.3%	0.0%	0.0%		85.3%	90.2%	100.0%	0.0%	91.6%	0.0%	0.0%		97.5%	96.6%	95.0%	0.0%	96.5%	0.0%	0.0%		96.3%	95.9%	100.0%	0.0%	96.6%	0.0%	0.0%		95.6%
Trucks	0	0	0	0	0	0	0		0	0	0	0	0	0	0		0	0	0	0	0	0	0		0	0	0	0	0	0	0		0
% Trucks	0.0%	0.0%	0.0%	0.0%	0.0%	0.0%	0.0%		0.0%	0.0%	0.0%	0.0%	0.0%	0.0%	0.0%		0.0%	0.0%	0.0%	0.0%	0.0%	0.0%	0.0%		0.0%	0.0%	0.0%	0.0%	0.0%	0.0%	0.0%		0.0%
Buses	0	10	0	0	10	0	0		5	9	0	0	14	0	0		1	7	2	0	10	0	0		1	4	0	0	5	0	0		39
% Buses	0.0%	4.2%	0.0%	0.0%	0.0%	0.0%	0.0%		14.7%	9.8%	0.0%	0.0%	0.0%	0.0%	0.0%		2.5%	3.0%	5.0%	0.0%	0.0%	0.0%	0.0%		3.7%	4.1%	0.0%	0.0%	0.0%	0.0%	0.0%		4.3%
Pedestrians	0	0	0	0	0	9	5		0	0	0	0	6	6	8		0	0	0	0	1	5	1		0	0	0	0	0	16	15		0
% Pedestrians	0.0%	0.0%	0.0%	0.0%	0.0%	100.0%	100.0%		0.0%	0.0%	0.0%	0.0%	0.0%	85.7%	100.0%		0.0%	0.0%	0.0%	0.0%	0.0%	50.0%	100.0%		0.0%	0.0%	0.0%	0.0%	0.0%	100.0%	100.0%		0.0%
Bicycles on Crosswalk	0	0	0	0	0	0	0		0	0	0	0	1	0	0		0	0	0	0	1	0	0		0	0	0	0	0	0	0		0
% Bicycles on Crosswalk	0.0%	0.0%	0.0%	0.0%	0.0%	0.0%	0.0%		0.0%	0.0%	0.0%	0.0%	0.0%	14.3%	0.0%		0.0%	0.0%	0.0%	0.0%	0.0%	50.0%	0.0%		0.0%	0.0%	0.0%	0.0%	0.0%	0.0%	0.0%		0.0%

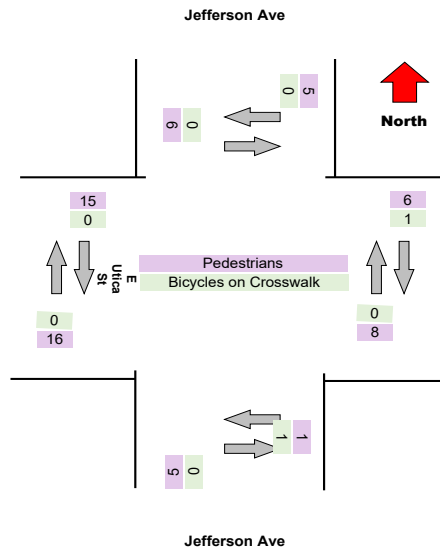
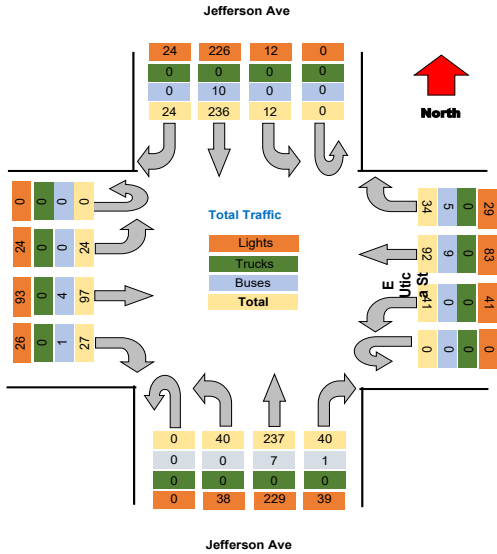

Project : VBH Malta NY
Site : Site 4
Location : 42.948550, -73.790036

TSTData.com

Survey Date : 2021-04-28, Wednesday

Project	LaBella
Project Code	LaBella
Site Name	33
Legs and Movements	All Processed Legs & Move
Bin Size	15 minutes
Survey Date	2021-11-02, Tuesday
Location	33
Latitude and Longitude	42.911146, -78.853969

	Start	End	PHF
Forced Peak AM	2021/11/02 07:30:00	2021/11/02 08:30:00	0.85
Forced Peak PM	2021/11/02 16:30:00	2021/11/02 17:30:00	0.85
AM Peak	2021/11/02 07:30:00	2021/11/02 08:30:00	0.85
PM Peak	2021/11/02 16:15:00	2021/11/02 17:15:00	0.93

Turning Movement Data

Leg Direction	Jefferson Ave										E Utica St										Total								
	Southbound					Westbound					Northbound					Eastbound													
	Right	Thru	Left	U-Turn	App Total	Peds CV	Peds CCV	Right	Thru	Left	U-Turn	App Total	Peds CV	Peds CCV	Right	Thru	Left	U-Turn	App Total	Peds CV		Peds CCV							
6:30:00 AM	0	7	2	0	9	0	1	2	4	3	0	10	0	1	1	12	3	0	17	0	0	4	6	1	0	11	1	0	47
6:45:00 AM	2	18	3	0	23	0	0	3	17	1	0	21	0	0	2	21	2	0	25	0	0	1	5	0	0	6	4	0	75
Hourly Total	2	25	5	0	32	0	1	5	21	4	0	31	0	1	3	33	5	0	42	0	0	5	11	1	0	17	5	0	122
7:00:00 AM	2	13	1	0	16	0	1	2	11	6	0	20	0	0	1	31	2	0	34	0	0	4	13	4	0	21	1	1	91
7:15:00 AM	1	25	0	0	26	1	2	6	8	4	0	20	0	0	0	24	3	0	27	0	0	6	7	1	0	14	1	1	87
7:30:00 AM	1	24	2	0	27	3	0	7	5	4	0	16	2	0	1	24	4	0	31	2	0	1	10	2	0	13	4	2	87
7:45:00 AM	3	22	4	0	29	0	0	1	18	1	0	20	0	0	4	20	3	0	27	0	0	4	6	1	0	11	3	2	87
Hourly Total	7	84	7	0	98	4	3	16	42	15	0	76	2	0	6	99	12	0	119	2	0	15	36	8	0	59	9	6	352
8:00:00 AM	2	25	1	0	28	0	0	5	20	2	0	27	0	1	5	21	8	0	36	0	0	7	15	1	0	23	7	5	113
8:15:00 AM	5	32	2	0	39	0	1	2	15	4	0	22	0	0	4	20	2	0	26	0	1	3	9	0	0	12	2	1	99
Hourly Total	7	57	3	0	67	0	1	7	35	6	0	49	0	1	9	41	10	0	61	0	1	10	24	1	0	35	9	6	212
4:00:00 PM	3	55	8	0	66	0	6	7	18	6	0	31	1	1	6	70	4	0	80	2	4	6	28	6	0	40	4	2	217
4:15:00 PM	7	55	4	0	66	1	1	11	19	7	0	37	0	1	5	58	4	0	67	0	0	11	20	3	0	34	1	1	204
4:30:00 PM	4	75	5	0	84	3	0	12	22	13	0	47	0	1	9	58	8	0	75	2	1	5	26	7	0	38	2	4	244
4:45:00 PM	7	53	5	0	65	0	3	8	22	7	0	37	0	1	9	67	8	0	84	0	0	9	27	3	0	39	4	9	225
Hourly Total	21	238	22	0	281	4	10	38	81	33	0	152	1	4	29	253	24	0	306	4	5	31	101	19	0	151	11	16	890
5:00:00 PM	2	63	4	0	69	3	0	9	28	9	0	44	1	0	17	64	7	0	88	4	1	9	21	4	0	34	4	2	235
5:15:00 PM	9	71	4	0	84	2	0	7	18	8	0	33	4	3	10	60	4	0	74	1	0	6	26	3	0	35	1	1	226
5:30:00 PM	10	42	5	0	57	0	2	5	16	8	0	29	1	1	9	57	5	0	71	1	3	8	22	3	0	33	3	1	190
5:45:00 PM	2	53	3	0	58	3	4	11	12	9	0	32	1	2	8	59	10	0	77	1	0	5	14	2	0	21	1	1	188
Hourly Total	23	229	16	0	268	8	6	32	72	34	0	138	7	6	44	240	26	0	310	7	4	28	83	12	0	123	9	5	839
Grand Total	60	633	53	0	746	15	21	98	251	92	0	446	10	12	91	666	77	0	838	13	10	89	255	41	0	385	43	23	2415
% Approach	8.0%	84.9%	7.1%	0.0%	0.0%	0.0%	0.0%	22.0%	56.3%	20.6%	0.0%	0.0%	0.0%	10.9%	79.5%	9.2%	0.0%	0.0%	0.0%	0.0%	23.1%	66.2%	10.6%	0.0%	0.0%	0.0%	0.0%	0.0%	
% Total	2.5%	26.2%	2.2%	0.0%	30.9%	0.0%	0.0%	4.1%	10.4%	3.8%	0.0%	18.5%	0.0%	0.0%	3.8%	27.6%	3.2%	0.0%	34.7%	0.0%	0.0%	3.7%	10.6%	1.7%	0.0%	15.9%	0.0%	0.0%	0.0%
Lights	59	619	51	0	729	0	0	97	236	92	0	425	0	0	87	655	75	0	817	0	0	89	240	40	0	369	0	0	2340
% Lights	98.3%	97.8%	96.2%	0.0%	97.7%	0.0%	0.0%	99.0%	94.0%	100.0%	0.0%	95.3%	0.0%	0.0%	95.0%	98.3%	97.4%	0.0%	97.8%	0.0%	0.0%	100.0%	94.1%	97.6%	0.0%	95.8%	0.0%	0.0%	96.9%
Trucks	0	2	0	0	2	0	0	0	0	0	0	0	0	0	0	0	0	0	0	0	0	0	0	0	0	0	0	0	2
% Trucks	0.0%	0.3%	0.0%	0.0%	0.3%	0.0%	0.0%	0.0%	0.0%	0.0%	0.0%	0.0%	0.0%	0.0%	0.0%	0.0%	0.0%	0.0%	0.0%	0.0%	0.0%	0.0%	0.0%	0.0%	0.0%	0.0%	0.0%	0.0%	0.1%
Buses	1	11	1	0	13	0	0	1	15	0	0	16	0	0	4	11	2	0	17	0	0	0	15	1	0	16	0	0	62
% Buses	1.7%	1.7%	1.9%	0.0%	0.0%	0.0%	0.0%	0.0%	6.0%	0.0%	0.0%	0.0%	0.0%	0.0%	4.4%	1.7%	2.6%	0.0%	0.0%	0.0%	0.0%	0.0%	5.9%	2.4%	0.0%	0.0%	0.0%	0.0%	2.6%
Pedestrians	0	0	0	0	0	16	21	0	0	0	0	0	10	11	0	0	0	0	0	13	10	0	0	0	0	0	41	32	0
% Pedestrians	0.0%	0.0%	0.0%	0.0%	0.0%	100.0%	100.0%	0.0%	0.0%	0.0%	0.0%	0.0%	100.0%	91.7%	0.0%	0.0%	0.0%	0.0%	0.0%	100.0%	100.0%	0.0%	0.0%	0.0%	0.0%	0.0%	85.3%	87.0%	0.0%
Bicycles on Crosswalk	0	0	0	0	0	0	0	0	0	0	0	0	0	1	0	0	0	0	0	0	0	0	0	0	0	0	2	1	0
% Bicycles on Crosswalk	0.0%	0.0%	0.0%	0.0%	0.0%	0.0%	0.0%	0.0%	0.0%	0.0%	0.0%	0.0%	0.0%	8.3%	0.0%	0.0%	0.0%	0.0%	0.0%	0.0%	0.0%	0.0%	0.0%	0.0%	0.0%	0.0%	4.7%	3.0%	0.0%

Turning Movement Data Plot

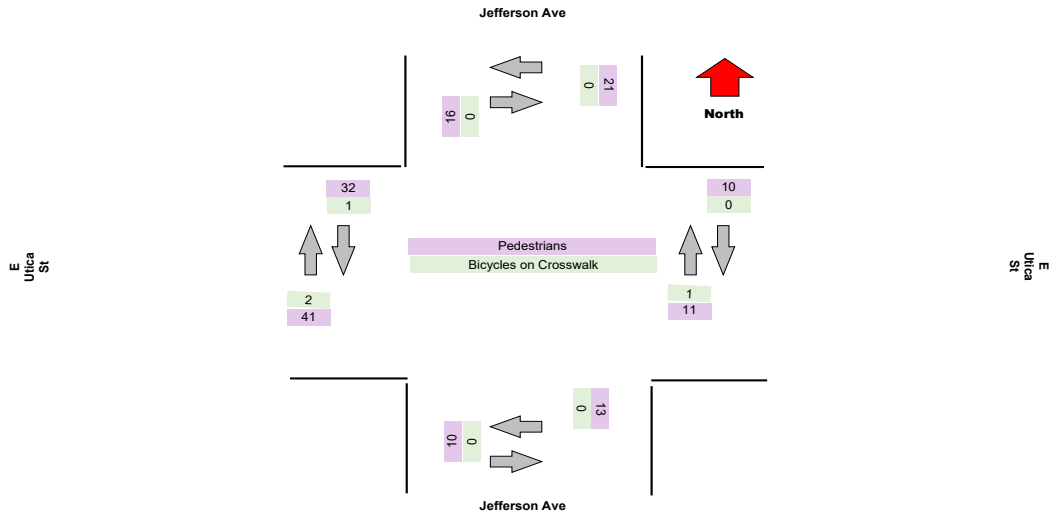
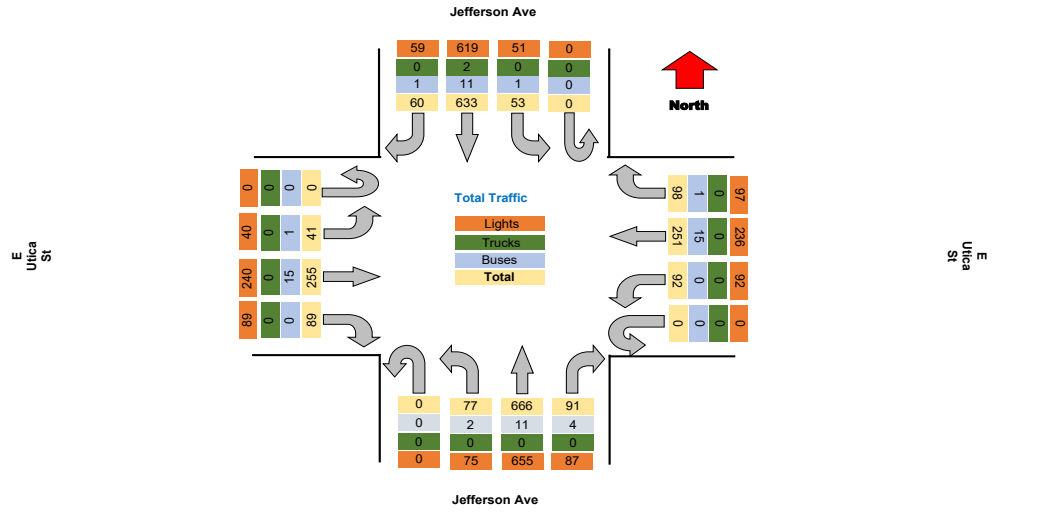

Project : VBH Malta NY
Site : Site 4
Location : 42.948550, -73.790036
Survey Date : 2021-04-28, Wednesday

TSTData.com

Turning Movement Peak Hour Data (AM)

7:30:00 AM

Leg Direction	Jefferson Ave				E Ulica St				Jefferson Ave				E Ulica St				Total				
	Southbound		Northbound		Westbound		Eastbound		Northbound		Eastbound		Westbound		Eastbound						
Start Time	Right	Thru	Left	U-Turn	App Total	Peds CW	Peds CCW	Right	Thru	Left	U-Turn	App Total	Peds CW	Peds CCW	Right	Thru	Left	U-Turn	App Total	Peds CW	Peds CCW
7:30:00 AM	1	24	2	0	27	3	0	7	5	4	0	16	2	0	1	24	4	0	31	2	0
7:45:00 AM	3	22	4	0	29	0	0	1	18	1	0	20	0	0	4	20	3	0	27	0	0
8:00:00 AM	2	25	1	0	28	0	0	5	20	2	0	27	0	1	5	21	8	0	35	0	0
8:15:00 AM	5	32	2	0	39	0	0	2	15	4	0	22	0	0	4	20	2	0	26	0	0
Grand Total	11	103	9	0	123	3	0	15	58	11	0	85	2	1	14	85	17	0	119	2	1
% Approach	8.9%	83.7%	7.3%	0.0%	0.0%	0.0%	0.0%	17.6%	68.2%	12.9%	0.0%	0.0%	0.0%	0.0%	11.8%	71.4%	14.3%	0.0%	0.0%	0.0%	0.0%
% Total	2.8%	26.7%	2.3%	0.0%	31.9%	0.0%	0.0%	3.9%	15.0%	2.8%	0.0%	22.0%	0.0%	0.0%	3.6%	22.0%	4.4%	0.0%	30.8%	0.0%	0.0%
PHF	0.550	0.805	0.563	0.000	0.788	0.000	0.000	0.536	0.725	0.688	0.000	0.787	0.000	0.000	0.700	0.885	0.531	0.000	0.850	0.000	0.000
Lights	11	101	9	0	121	0	0	15	54	11	0	80	0	0	13	81	17	0	111	0	0
% Trucks	100.0%	98.1%	100.0%	0.0%	98.4%	0.0%	0.0%	100.0%	93.1%	100.0%	0.0%	94.1%	0.0%	0.0%	92.9%	95.3%	100.0%	0.0%	93.3%	0.0%	0.0%
% Buses	0.0%	1.0%	0.0%	0.0%	0.0%	0.0%	0.0%	0.0%	6.9%	0.0%	0.0%	0.0%	0.0%	0.0%	7.1%	4.7%	0.0%	0.0%	0.0%	0.0%	0.0%
Pedestrians	0	0	0	0	0	3	1	0	0	0	0	2	1	0	0	0	0	0	0	0	0
% Pedestrians	0.0%	0.0%	0.0%	0.0%	0.0%	100.0%	100.0%	0.0%	0.0%	0.0%	0.0%	0.0%	100.0%	100.0%	0.0%	0.0%	0.0%	0.0%	0.0%	0.0%	100.0%
Bicycles on Crosswalk	0	0	0	0	0	0	0	0	0	0	0	0	0	0	0	0	0	0	0	0	0
% Bicycles on Crosswalk	0.0%	0.0%	0.0%	0.0%	0.0%	0.0%	0.0%	0.0%	0.0%	0.0%	0.0%	0.0%	0.0%	0.0%	0.0%	0.0%	0.0%	0.0%	0.0%	0.0%	0.0%

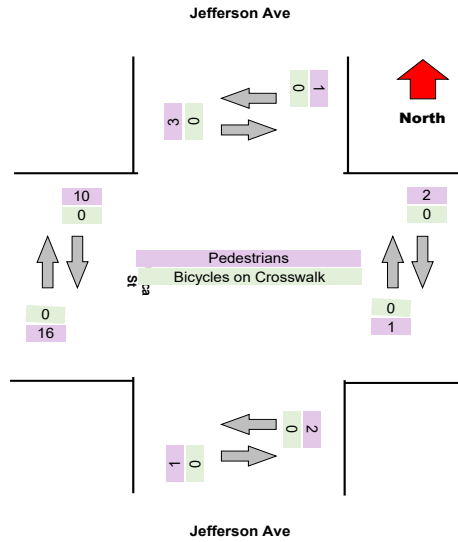
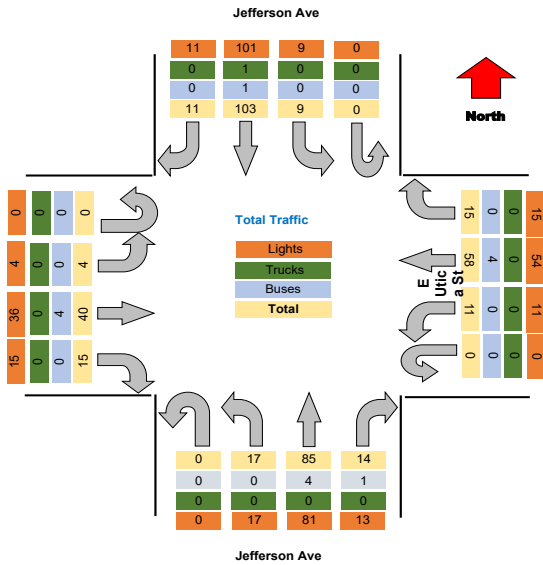

Project : VBH Malta NY
Site : Site 4
Location : 42.948550, -73.790036

TSTData.com

Survey Date : 2021-04-28, Wednesday

Turning Movement Peak Hour Data (PM)

4:15:00 PM

Leg Direction	Jefferson Ave										E Ulica St										Jefferson Ave										E Ulica St										Total
	Southbound					Westbound					Northbound					Eastbound																									
	Right	Thru	Left	U-Turn	App Total	Right	Thru	Left	U-Turn	App Total	Right	Thru	Left	U-Turn	App Total	Right	Thru	Left	U-Turn	App Total																					
4:15:00 PM	7	55	4	0	66	11	19	7	0	37	5	58	4	0	67	11	20	3	0	34																					
4:30:00 PM	4	75	5	0	84	12	22	13	0	47	9	58	8	0	75	5	26	7	0	38																					
4:45:00 PM	7	53	5	0	65	8	22	7	0	37	9	67	8	0	84	9	27	3	0	39																					
5:00:00 PM	2	53	4	0	59	9	25	9	0	44	17	54	7	0	80	9	21	4	0	34																					
Grand Total	20	245	15	0	284	40	89	35	0	165	40	247	27	0	314	34	94	17	0	145																					
% Approach	7.0%	86.6%	6.3%	0.0%	0.0%	24.2%	53.9%	21.8%	0.0%	0.0%	12.7%	78.7%	8.6%	0.0%	0.0%	23.4%	64.8%	11.7%	0.0%	0.0%																					
% Total	2.2%	27.1%	2.0%	0.0%	31.3%	4.4%	9.8%	4.0%	0.0%	18.2%	4.4%	27.2%	3.0%	0.0%	34.6%	3.7%	10.4%	1.9%	0.0%	16.0%																					
PHF	0.714	0.820	0.900	0.000	0.845	0.833	0.856	0.692	0.000	0.878	0.588	0.922	0.844	0.000	0.892	0.773	0.870	0.607	0.000	0.929																					
Lights	20	241	17	0	278	39	86	36	0	161	39	244	26	0	309	34	91	17	0	142																					
% Lights	100.0%	98.0%	94.4%	0.0%	97.9%	97.5%	96.6%	100.0%	0.0%	97.6%	97.5%	98.8%	96.3%	0.0%	98.4%	100.0%	96.8%	100.0%	0.0%	97.9%																					
Trucks	0	1	0	0	1	0	0	0	0	0	0	0	0	0	0	0	0	0	0	0																					
% Trucks	0.0%	0.4%	0.0%	0.0%	0.4%	0.0%	0.0%	0.0%	0.0%	0.0%	0.0%	0.0%	0.0%	0.0%	0.0%	0.0%	0.0%	0.0%	0.0%	0.0%																					
Buses	0	3	0	0	3	1	3	0	0	4	1	3	1	0	5	0	3	0	0	3																					
% Buses	0.0%	1.2%	0.0%	0.0%	0.0%	2.5%	3.4%	0.0%	0.0%	0.0%	2.5%	1.2%	3.7%	0.0%	0.0%	0.0%	3.2%	0.0%	0.0%	0.0%																					
Pedestrians	0	0	0	0	0	7	4	0	0	1	6	6	2	0	14	0	0	0	0	0																					
% Pedestrians	0.0%	0.0%	0.0%	0.0%	0.0%	100.0%	100.0%	0.0%	0.0%	0.0%	0.0%	0.0%	0.0%	0.0%	0.0%	0.0%	0.0%	0.0%	0.0%	0.0%																					
Bicycles on Crosswalk	0	0	0	0	0	0	0	0	0	0	0	0	0	0	0	0	0	0	0	0																					
% Bicycles on Crosswalk	0.0%	0.0%	0.0%	0.0%	0.0%	0.0%	0.0%	0.0%	0.0%	0.0%	0.0%	0.0%	0.0%	0.0%	0.0%	0.0%	0.0%	0.0%	0.0%	0.0%																					

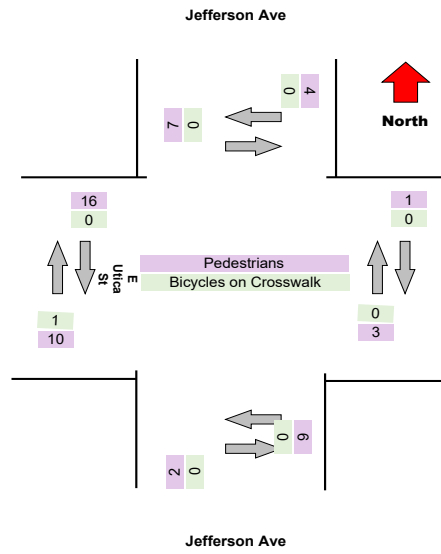
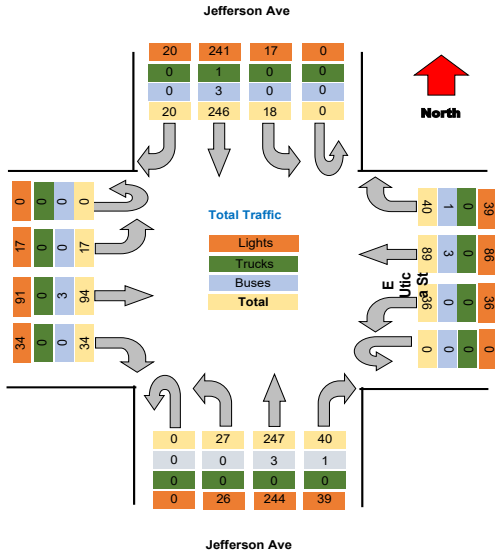

Turning Movement Data Plot

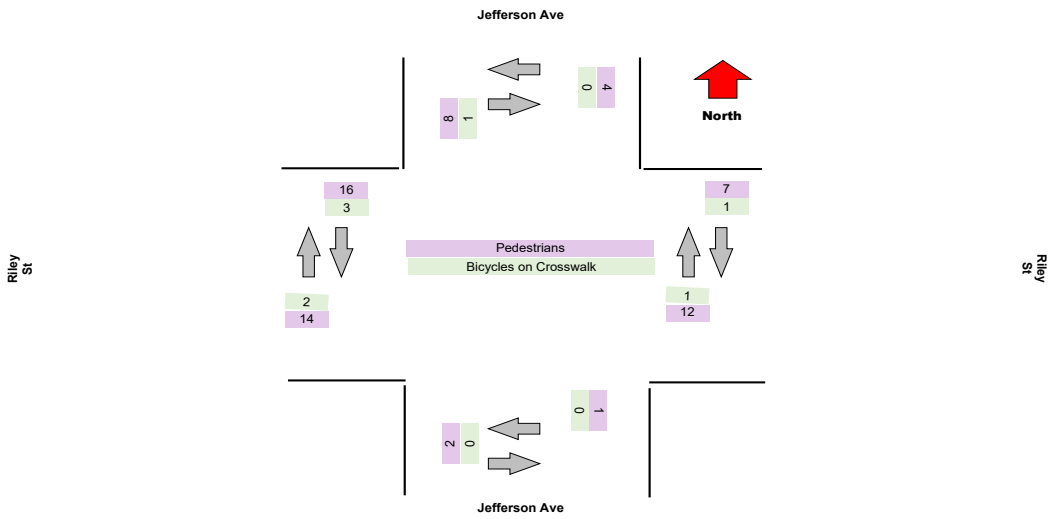
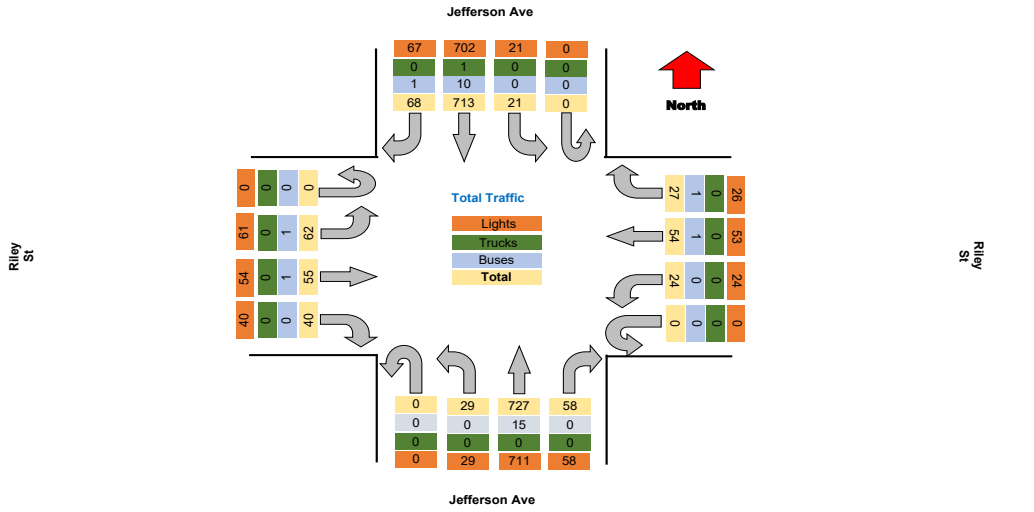

Project : VBH Malta NY
Site : Site 4
Location : 42.948550, -73.790036

TSTData.com

Survey Date : 2021-04-28, Wednesday

Turning Movement Peak Hour Data (AM)

7:30:00 AM

Leg Direction	Jefferson Ave						Riley St						Jefferson Ave						Riley St						Total					
	Southbound			Westbound			Northbound			Eastbound			Northbound			Eastbound														
Start Time	Right	Thru	Left	U-Turn	App Total	Peds CW	Peds CCW	Right	Thru	Left	U-Turn	App Total	Peds CW	Peds CCW	Right	Thru	Left	U-Turn	App Total	Peds CW	Peds CCW	Right	Thru	Left	U-Turn	App Total	Peds CW	Peds CCW		
7:30:00 AM	1	23	0	0	24	1	1	0	3	0	0	4	0	1	1	24	0	0	0	26	0	0	1	2	3	0	6	3	2	60
7:45:00 AM	1	28	0	0	29	0	1	0	6	0	0	7	0	0	2	26	0	0	28	0	0	1	2	0	0	3	0	1	67	
8:00:00 AM	2	29	0	0	31	0	0	0	3	3	0	7	0	0	5	26	4	0	35	0	0	6	2	5	0	13	1	0	85	
8:15:00 AM	0	40	0	0	40	0	0	1	5	0	0	7	0	0	2	26	1	0	29	0	0	10	6	3	0	19	1	1	95	
Grand Total	4	120	0	0	124	1	2	1	18	3	0	24	0	1	10	102	5	0	118	0	0	19	12	11	0	41	3	4	397	
% Approach	3.2%	96.8%	0.0%	0.0%	0.0%	0.0%	0.0%	4.2%	75.0%	12.5%	0.0%	0.0%	0.0%	0.0%	8.5%	96.4%	4.2%	0.0%	0.0%	0.0%	0.0%	43.9%	29.3%	26.8%	0.0%	0.0%	0.0%	0.0%	0.0%	
% Total	1.3%	39.1%	0.0%	0.0%	40.4%	0.0%	0.0%	0.3%	5.9%	1.0%	0.0%	7.8%	0.0%	0.0%	3.3%	33.2%	1.6%	0.0%	38.4%	0.0%	0.0%	5.9%	3.9%	3.6%	0.0%	13.4%	0.0%	0.0%	0.0%	
PHF	0.500	0.750	0.000	0.000	0.775	0.000	0.000	0.250	0.750	0.250	0.000	0.857	0.000	0.000	0.500	0.981	0.313	0.000	0.843	0.000	0.000	0.450	0.500	0.550	0.000	0.539	0.000	0.000	0.808	
Lights	4	119	0	0	123	0	0	1	18	3	0	22	0	0	10	97	5	0	112	0	0	18	12	11	0	41	0	0	298	
% Lights	100.0%	99.2%	0.0%	0.0%	99.2%	0.0%	0.0%	100.0%	100.0%	100.0%	0.0%	91.7%	0.0%	0.0%	100.0%	95.1%	100.0%	0.0%	94.9%	0.0%	0.0%	100.0%	100.0%	100.0%	0.0%	100.0%	0.0%	0.0%	97.1%	
Trucks	0	0	0	0	0	0	0	0	0	0	0	0	0	0	0	0	0	0	0	0	0	0	0	0	0	0	0	0	0	
% Trucks	0.0%	0.0%	0.0%	0.0%	0.0%	0.0%	0.0%	0.0%	0.0%	0.0%	0.0%	0.0%	0.0%	0.0%	0.0%	0.0%	0.0%	0.0%	0.0%	0.0%	0.0%	0.0%	0.0%	0.0%	0.0%	0.0%	0.0%	0.0%	0.0%	
Buses	0	1	0	0	1	0	0	0	0	0	0	0	0	0	0	5	0	0	5	0	0	0	0	0	0	0	0	0	6	
% Buses	0.0%	0.8%	0.0%	0.0%	0.0%	0.0%	0.0%	0.0%	0.0%	0.0%	0.0%	0.0%	0.0%	0.0%	0.0%	4.9%	0.0%	0.0%	0.0%	0.0%	0.0%	0.0%	0.0%	0.0%	0.0%	0.0%	0.0%	0.0%	2.0%	
Pedestrians	0	0	0	0	0	1	2	0	0	0	0	0	1	0	0	0	0	0	0	0	0	0	0	0	0	0	5	3	0	
% Pedestrians	0.0%	0.0%	0.0%	0.0%	0.0%	100.0%	100.0%	0.0%	0.0%	0.0%	0.0%	0.0%	0.0%	100.0%	0.0%	0.0%	0.0%	0.0%	0.0%	0.0%	0.0%	0.0%	0.0%	0.0%	0.0%	0.0%	0.0%	100.0%	75.0%	0.0%
Bicycles on Crosswalk	0	0	0	0	0	0	0	0	0	0	0	0	0	0	0	0	0	0	0	0	0	0	0	0	0	0	0	1	0	
% Bicycles on Crosswalk	0.0%	0.0%	0.0%	0.0%	0.0%	0.0%	0.0%	0.0%	0.0%	0.0%	0.0%	0.0%	0.0%	0.0%	0.0%	0.0%	0.0%	0.0%	0.0%	0.0%	0.0%	0.0%	0.0%	0.0%	0.0%	0.0%	0.0%	25.0%	0.0%	

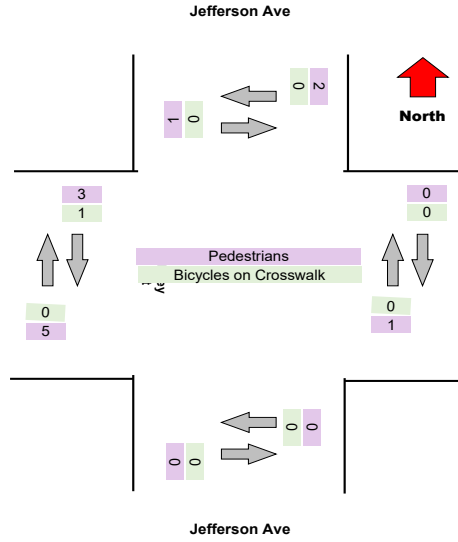
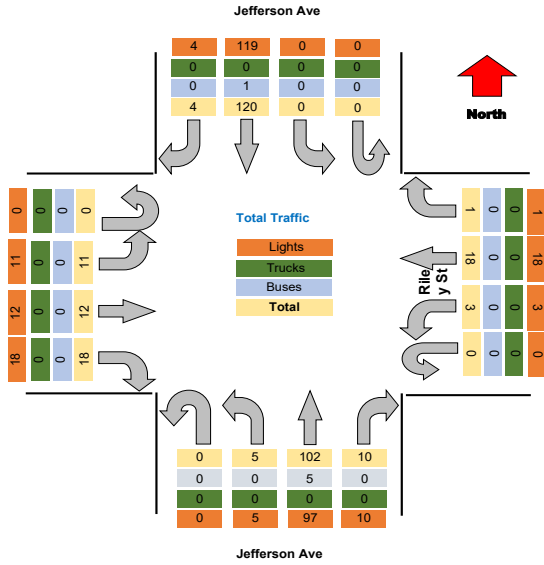

Turning Movement Peak Hour Data (PM)

4:15:00 PM

Leg Direction	Jefferson Ave										Riley St										Jefferson Ave										Riley St										Total
	Southbound					Westbound					Northbound					Eastbound					Northbound					Eastbound															
	Right	Thru	Left	U-Turn	App Total	Right	Thru	Left	U-Turn	App Total	Right	Thru	Left	U-Turn	App Total	Right	Thru	Left	U-Turn	App Total	Right	Thru	Left	U-Turn	App Total	Right	Thru	Left	U-Turn	App Total	Peds CW	Peds CCW									
4:15:00 PM	8	55	3	0	66	2	4	5	0	11	4	60	3	0	67	2	3	5	0	10	11	71	2	0	84	1	1	1	0	3	0	0									
4:30:00 PM	10	86	4	0	100	4	2	1	0	7	7	2	2	0	11	3	69	3	0	75	2	7	5	0	14	2	2	2	0	6	0	0									
4:45:00 PM	6	58	3	0	67	4	4	3	0	11	4	3	0	0	7	4	54	2	0	60	0	5	9	0	14	1	1	1	0	3	0	0									
5:00:00 PM	11	52	2	0	65	4	4	1	0	9	1	1	1	0	3	2	2	0	0	4	0	5	9	0	14	0	0														
Grand Total	35	257	12	0	304	14	14	10	0	38	22	234	10	0	316	5	18	25	0	48	49	141	11	0	161	4	5														
% Approach	11.4%	84.7%	3.9%	0.0%	0.0%	36.8%	36.8%	26.3%	0.0%	0.0%	7.0%	89.9%	3.2%	0.0%	0.0%	10.2%	36.7%	53.1%	0.0%	0.0%	10.2%	36.7%	53.1%	0.0%	0.0%	0.0%	0.0%														
% Total	4.9%	36.7%	1.7%	0.0%	43.3%	2.0%	2.0%	1.4%	0.0%	5.3%	3.1%	39.9%	1.4%	0.0%	44.4%	0.7%	2.5%	3.7%	0.0%	6.9%	0.7%	2.5%	3.7%	0.0%	6.9%	0.0%	0.0%														
PHF	0.795	0.759	0.750	0.000	0.770	0.875	0.875	0.500	0.000	0.864	0.500	0.845	0.833	0.000	0.878	0.625	0.643	0.722	0.000	0.875	0.000	0.000	0.000	0.000	0.000	0.000	0.000														
Lights	35	257	12	0	304	13	14	10	0	37	22	279	10	0	311	5	18	25	0	48	49	141	11	0	161	4	5														
% Lights	100.0%	98.5%	100.0%	0.0%	98.7%	82.9%	100.0%	100.0%	0.0%	97.4%	100.0%	98.2%	100.0%	0.0%	98.4%	100.0%	100.0%	98.2%	0.0%	98.0%	100.0%	100.0%	98.2%	0.0%	98.0%	0.0%	0.0%														
Trucks	0	1	0	0	1	0	0	0	0	0	0	0	0	0	0	0	0	0	0	0	0	0	0	0	0	0	0														
% Trucks	0.0%	0.4%	0.0%	0.0%	0.3%	0.0%	0.0%	0.0%	0.0%	0.0%	0.0%	0.0%	0.0%	0.0%	0.0%	0.0%	0.0%	0.0%	0.0%	0.0%	0.0%	0.0%	0.0%	0.0%	0.0%	0.0%	0.0%														
Buses	0	3	0	0	3	1	0	0	0	1	0	4	0	0	4	0	0	1	0	1	0	0	0	0	0	0	0														
% Buses	0.0%	1.1%	0.0%	0.0%	0.9%	7.1%	0.0%	0.0%	0.0%	0.0%	0.0%	1.4%	0.0%	0.0%	0.0%	0.0%	0.0%	3.8%	0.0%	0.0%	0.0%	0.0%	3.8%	0.0%	0.0%	0.0%	0.0%														
Pedestrians	0	0	0	0	0	0	0	0	0	0	4	6	0	1	11	0	0	0	0	0	0	0	0	0	0	3	5														
% Pedestrians	0.0%	0.0%	0.0%	0.0%	0.0%	0.0%	0.0%	0.0%	0.0%	0.0%	80.0%	85.7%	0.0%	100.0%	0.0%	0.0%	0.0%	0.0%	0.0%	0.0%	0.0%	0.0%	0.0%	0.0%	0.0%	75.0%	100.0%														
Bicycles on Crosswalk	0	0	0	0	0	0	0	0	0	1	0	0	0	0	0	0	0	0	0	0	0	0	0	0	0	0	1														
% Bicycles on Crosswalk	0.0%	0.0%	0.0%	0.0%	0.0%	0.0%	0.0%	0.0%	0.0%	0.0%	0.0%	0.0%	0.0%	0.0%	0.0%	0.0%	0.0%	0.0%	0.0%	0.0%	0.0%	0.0%	0.0%	0.0%	0.0%	0.0%	20.0%														

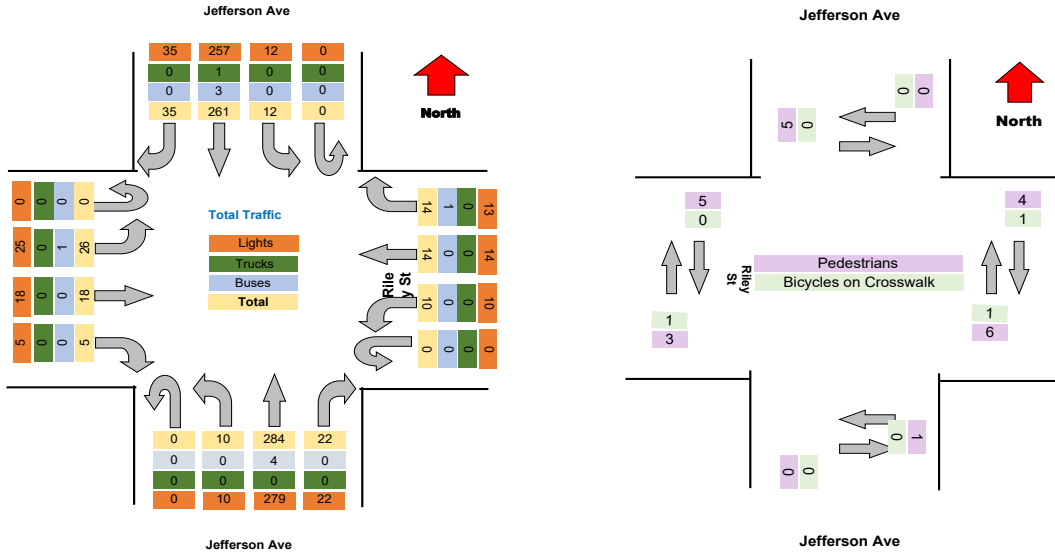



Project : VBH Malta NY
 Site : Site 4
 Location : 42.948550, -73.790036

TSTData.com

Survey Date : 2021-04-28, Wednesday

Project	LaBella
Project Code	LaBella
Site Name	34
Legs and Movements	All Processed Legs & Move
Bin Size	15 minutes
Survey Date	2021-11-03, Wednesday
Location	34
Latitude and Longitude	42.909386, -78.853967

	Start	End	PHF
Forced Peak AM	2021/11/03 07:30:00	2021/11/03 08:30:00	0.89
Forced Peak PM	2021/11/03 16:30:00	2021/11/03 17:30:00	0.91
AM Peak	2021/11/03 07:30:00	2021/11/03 08:30:00	0.89
PM Peak	2021/11/03 16:15:00	2021/11/03 17:15:00	0.92

Turning Movement Data

Leg Direction	Jefferson Ave								Riley St								Jefferson Ave								Riley St								Total
	Southbound				Westbound				Northbound				Eastbound				Westbound				Eastbound												
	Right	Thru	Left	U-Turn	App Total	Peds CW	Peds CCW		Right	Thru	Left	U-Turn	App Total	Peds CW	Peds CCW		Right	Thru	Left	U-Turn	App Total	Peds CW	Peds CCW		Right	Thru	Left	U-Turn	App Total	Peds CW	Peds CCW		
6:30:00 AM	1	12	0	0	13	0	0		0	2	0	0	2	0	0		2	19	0	0	21	0	0		1	2	3	0	6	1	0	42	
6:45:00 AM	2	18	0	0	20	0	0		2	0	3	0	5	0	2		3	22	1	0	28	0	0		2	2	0	0	4	2	0	57	
Hourly Total	3	30	0	0	33	0	0		2	2	3	0	7	0	2		5	41	1	0	49	0	0		3	4	3	0	10	3	0	99	
7:00:00 AM	1	28	0	0	29	0	0		2	3	2	0	7	0	0		2	41	1	0	44	0	0		2	2	3	0	7	1	2	85	
7:15:00 AM	2	30	2	0	34	0	1		3	4	1	0	8	0	0		7	31	0	0	38	0	0		2	1	0	0	3	0	0	84	
7:30:00 AM	2	31	0	0	33	0	0		0	6	2	0	8	0	0		3	29	3	0	35	0	0		8	4	0	0	12	2	1	88	
7:45:00 AM	2	64	0	0	66	4	1		3	2	1	0	7	0	0		0	38	1	0	39	0	0		0	5	0	0	5	5	0	117	
Hourly Total	7	151	2	0	160	4	2		8	15	6	0	31	0	0		12	139	5	0	156	0	0		12	12	3	0	27	8	3	374	
8:00:00 AM	3	54	1	0	58	0	0		0	1	3	0	4	0	0		1	44	3	0	48	0	0		3	6	3	0	12	0	1	122	
8:15:00 AM	1	37	0	0	38	1	0		2	5	1	0	8	0	1		2	43	1	0	47	0	0		2	7	4	0	13	3	1	106	
Hourly Total	4	91	1	0	96	1	0		2	6	4	0	12	0	1		3	87	4	0	95	0	0		5	13	7	0	25	3	2	228	
4:00:00 PM	5	61	1	0	67	0	0		2	3	4	0	9	1	0		9	82	2	0	93	1	0		3	9	4	0	16	2	3	185	
4:15:00 PM	1	68	2	0	71	1	6		4	4	4	0	12	0	1		9	79	1	0	89	0	0		1	8	2	0	11	0	0	183	
4:30:00 PM	9	61	5	0	95	0	1		4	3	4	0	11	2	2		12	60	0	0	72	0	0		5	7	4	0	18	0	0	194	
4:45:00 PM	3	54	2	0	59	0	0		3	6	5	0	14	0	2		7	72	1	0	80	0	1		1	5	2	0	8	1	0	161	
Hourly Total	18	264	10	0	292	1	7		13	18	17	0	48	3	5		37	293	4	0	334	1	1		10	29	12	0	51	3	3	723	
5:00:00 PM	4	79	1	0	84	0	0		5	6	2	0	13	0	1		9	80	4	0	93	0	1		3	6	3	0	12	2	2	202	
5:15:00 PM	11	60	2	0	73	0	2		1	4	3	0	8	1	0		4	75	1	0	80	3	0		3	10	3	0	16	0	3	177	
5:30:00 PM	6	66	3	0	75	0	0		2	2	2	0	6	0	2		5	61	2	0	68	1	0		2	7	3	0	12	1	1	161	
5:45:00 PM	4	59	2	0	65	0	2		0	2	1	0	3	1	0		2	51	1	0	54	0	0		2	1	3	0	6	3	2	128	
Hourly Total	25	264	6	0	297	0	4		6	14	8	0	30	2	3		20	267	8	0	295	4	1		10	24	12	0	46	6	8	668	
Grand Total	57	800	21	0	878	6	13		33	53	38	0	126	5	11		77	827	22	0	929	5	2		40	82	37	0	159	23	16	2092	
% Approach	6.5%	91.1%	2.4%	0.0%	0.0%	0.0%	0.0%		26.2%	42.1%	30.2%	0.0%	0.0%	0.0%	0.0%		6.3%	89.0%	2.4%	0.0%	0.0%	0.0%	0.0%		25.2%	51.6%	23.3%	0.0%	0.0%	0.0%	0.0%	0.0%	
% Total	2.7%	38.2%	1.0%	0.0%	42.0%	0.0%	0.0%		1.6%	2.5%	1.8%	0.0%	6.0%	0.0%	0.0%		3.7%	39.5%	1.1%	0.0%	44.4%	0.0%	0.0%		1.9%	3.9%	1.8%	0.0%	7.6%	0.0%	0.0%	0.0%	
Lights	56	758	19	0	833	0	0		29	51	36	0	116	0	0		75	796	19	0	890	0	0		36	76	35	0	147	0	0	1886	
% Lights	98.2%	94.8%	90.5%	0.0%	94.9%	0.0%	0.0%		87.9%	86.2%	94.7%	0.0%	92.1%	0.0%	0.0%		87.4%	86.3%	88.4%	0.0%	95.8%	0.0%	0.0%		90.0%	92.7%	94.6%	0.0%	92.5%	0.0%	0.0%	94.9%	
Trucks	0	2	0	0	2	0	0		0	0	0	0	0	0	0		0	0	0	0	0	0	0		0	0	0	0	0	0	0	2	
% Trucks	0.0%	0.3%	0.0%	0.0%	0.2%	0.0%	0.0%		0.0%	0.0%	0.0%	0.0%	0.0%	0.0%	0.0%		0.0%	0.0%	0.0%	0.0%	0.0%	0.0%	0.0%		0.0%	0.0%	0.0%	0.0%	0.0%	0.0%	0.0%	0.1%	
Buses	1	40	2	0	43	0	0		4	2	2	0	8	0	0		2	31	3	0	36	0	0		4	6	2	0	12	0	0	99	
% Buses	1.8%	5.0%	9.5%	0.0%	0.0%	0.0%	0.0%		0.0%	3.8%	5.3%	0.0%	0.0%	0.0%	0.0%		2.6%	3.7%	13.6%	0.0%	0.0%	0.0%	0.0%		10.0%	7.3%	5.4%	0.0%	0.0%	0.0%	0.0%	4.7%	
Pedestrians	0	0	0	0	0	6	13		0	0	0	0	0	5	11		0	0	0	0	0	5	2		0	0	0	0	0	23	15	0	
% Pedestrians	0.0%	0.0%	0.0%	0.0%	0.0%	100.0%	100.0%		0.0%	0.0%	0.0%	0.0%	0.0%	100.0%	100.0%		0.0%	0.0%	0.0%	0.0%	0.0%	100.0%	100.0%		0.0%	0.0%	0.0%	0.0%	0.0%	100.0%	93.8%	0.0%	
Bicycles on Crosswalk	0	0	0	0	0	0	0		0	0	0	0	0	0	0		0	0	0	0	0	0	0		0	0	0	0	0	0	1	0	
% Bicycles on Crosswalk	0.0%	0.0%	0.0%	0.0%	0.0%	0.0%	0.0%		0.0%	0.0%	0.0%	0.0%	0.0%	0.0%	0.0%		0.0%	0.0%	0.0%	0.0%	0.0%	0.0%	0.0%		0.0%	0.0%	0.0%	0.0%	0.0%	0.0%	6.3%	0.0%	

Project : VBH Malta NY
 Site : Site 4
 Location : 42.948550, -73.790036
 Survey Date : 2021-04-28, Wednesday

Turning Movement Data Plot

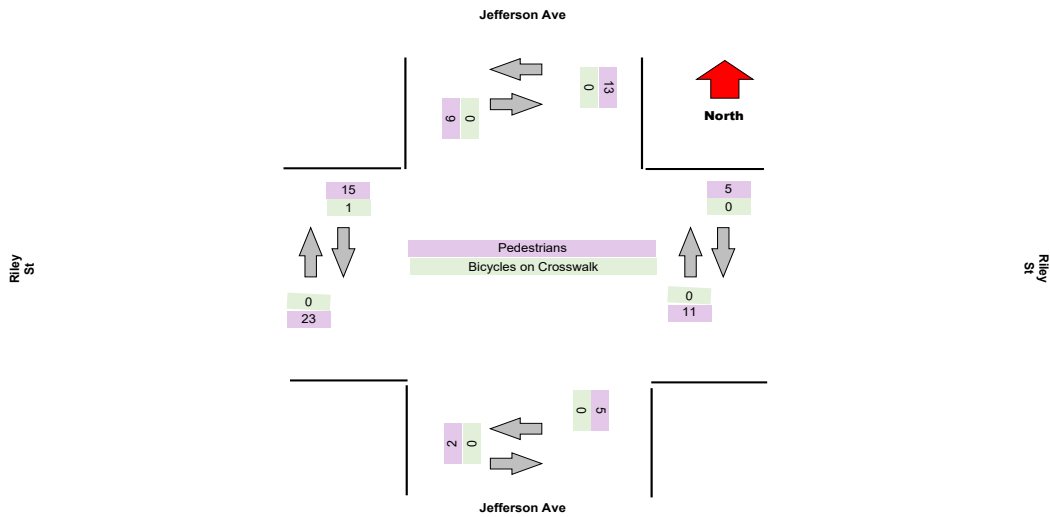
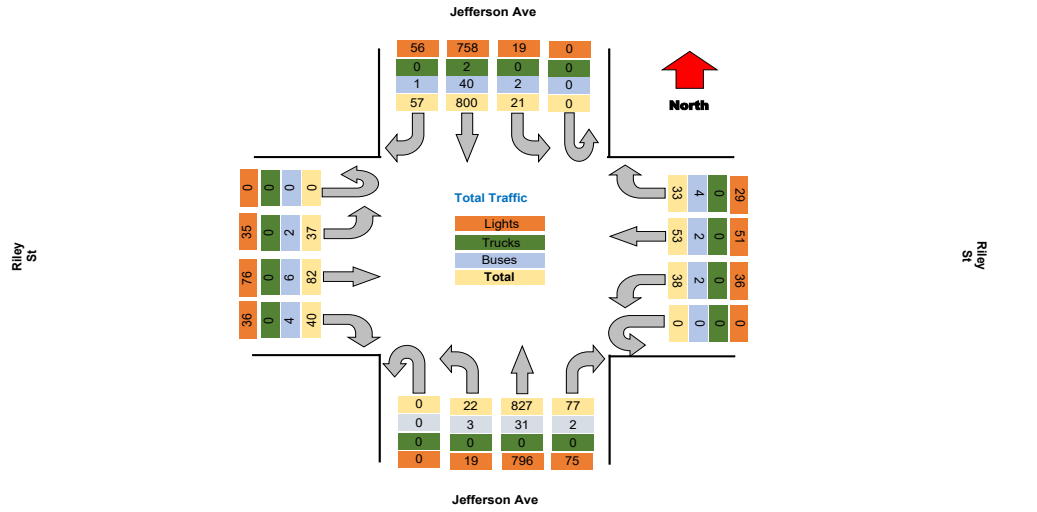

Project : VBH Malta NY
Site : Site 4
Location : 42.948550, -73.790036

TSTData.com

Survey Date : 2021-04-28, Wednesday

Turning Movement Peak Hour Data (AM)

7:30:00 AM

Leg Direction	Jefferson Ave				Riley St				Jefferson Ave				Riley St				Total													
	Southbound		Northbound		Westbound		Eastbound		Northbound		Southbound		Eastbound																	
Start Time	Right	Thru	Left	U-Turn	App Total	Peds CW	Peds CCW	Right	Thru	Left	U-Turn	App Total	Peds CW	Peds CCW	Right	Thru	Left	U-Turn	App Total	Peds CW	Peds CCW									
7:30:00 AM	2	31	0	0	33	0	0	0	6	2	0	8	0	0	3	29	3	0	35	0	0	8	4	0	0	12	2	1	88	
7:45:00 AM	2	64	0	0	66	4	1	3	2	1	0	7	0	0	0	38	1	0	39	0	0	0	5	0	0	5	5	0	117	
8:00:00 AM	3	54	1	0	58	0	0	0	1	3	0	4	0	0	1	44	3	0	48	0	0	0	6	3	0	12	0	1	122	
8:15:00 AM	1	37	0	0	38	1	0	2	5	1	0	8	0	1	2	43	1	0	47	0	0	0	7	4	0	13	3	1	106	
Grand Total	9	186	1	0	195	5	1	5	14	7	0	27	0	1	6	154	8	0	169	0	0	13	22	7	0	42	13	3	433	
% Approach	4.1%	95.4%	0.5%	0.0%	0.0%	0.0%	0.0%	18.5%	51.9%	25.9%	0.0%	0.0%	0.0%	0.0%	3.6%	91.1%	4.7%	0.0%	0.0%	0.0%	0.0%	31.0%	52.4%	16.7%	0.0%	0.0%	0.0%	0.0%	0.0%	
% Total	1.8%	43.0%	0.2%	0.0%	45.0%	0.0%	0.0%	1.2%	3.2%	1.6%	0.0%	6.2%	0.0%	0.0%	1.4%	35.6%	1.8%	0.0%	39.0%	0.0%	0.0%	3.0%	5.1%	1.6%	0.0%	9.7%	0.0%	0.0%		
PHF	0.667	0.727	0.250	0.000	0.739	0.000	0.000	0.417	0.583	0.583	0.000	0.844	0.000	0.000	0.500	0.875	0.667	0.000	0.880	0.000	0.000	0.406	0.786	0.438	0.000	0.808	0.000	0.000	0.887	
Lights	8	171	1	0	180	0	0	3	14	5	0	22	0	0	6	138	7	0	151	0	0	11	21	7	0	39	0	0	392	
% Lights	100.0%	91.9%	100.0%	0.0%	92.3%	0.0%	0.0%	80.0%	100.0%	71.4%	0.0%	81.5%	0.0%	0.0%	100.0%	89.6%	87.5%	0.0%	89.3%	0.0%	0.0%	84.6%	95.5%	100.0%	0.0%	92.9%	0.0%	0.0%	90.5%	
Trucks	0	1	0	0	1	0	0	0	0	0	0	0	0	0	0	0	0	0	0	0	0	0	0	0	0	0	0	0	1	
% Trucks	0.0%	0.5%	0.0%	0.0%	0.5%	0.0%	0.0%	0.0%	0.0%	0.0%	0.0%	0.0%	0.0%	0.0%	0.0%	0.0%	0.0%	0.0%	0.0%	0.0%	0.0%	0.0%	0.0%	0.0%	0.0%	0.0%	0.0%	0.0%	0.2%	
Buses	0	14	0	0	14	0	0	2	0	2	0	4	0	0	0	16	1	0	17	0	0	2	1	0	0	3	0	0	38	
% Buses	0.0%	7.5%	0.0%	0.0%	0.0%	0.0%	0.0%	40.0%	0.0%	28.6%	0.0%	0.0%	0.0%	0.0%	0.0%	10.4%	12.5%	0.0%	0.0%	0.0%	0.0%	15.4%	4.5%	0.0%	0.0%	0.0%	0.0%	0.0%	8.8%	
Pedestrians	0	0	0	0	0	5	1	0	0	0	0	0	1	0	0	0	0	0	0	0	0	0	0	0	0	0	10	3	0	
% Pedestrians	0.0%	0.0%	0.0%	0.0%	0.0%	100.0%	100.0%	0.0%	0.0%	0.0%	0.0%	0.0%	0.0%	0.0%	0.0%	0.0%	0.0%	0.0%	0.0%	0.0%	0.0%	0.0%	0.0%	0.0%	0.0%	0.0%	0.0%	100.0%	100.0%	0.0%
Bicycles on Crosswalk	0	0	0	0	0	0	0	0	0	0	0	0	0	0	0	0	0	0	0	0	0	0	0	0	0	0	0	0	0	
% Bicycles on Crosswalk	0.0%	0.0%	0.0%	0.0%	0.0%	0.0%	0.0%	0.0%	0.0%	0.0%	0.0%	0.0%	0.0%	0.0%	0.0%	0.0%	0.0%	0.0%	0.0%	0.0%	0.0%	0.0%	0.0%	0.0%	0.0%	0.0%	0.0%	0.0%	0.0%	0.0%

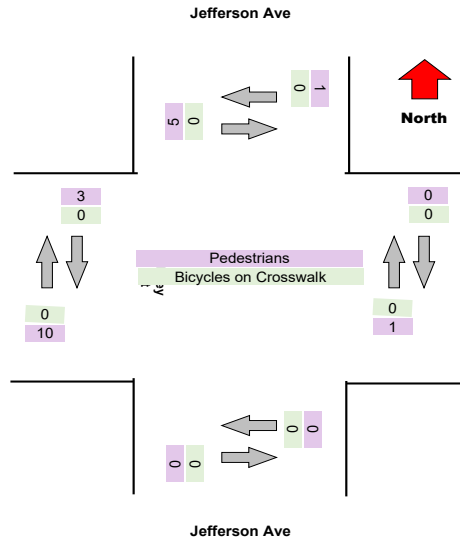
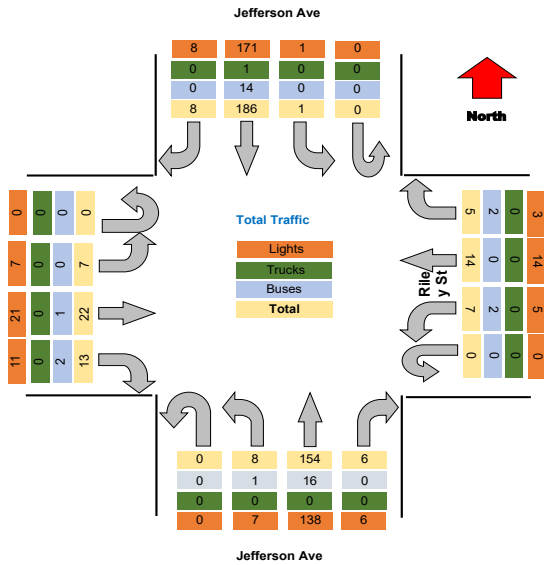

Turning Movement Peak Hour Data (PM)

4:15:00 PM

Leg Direction	Jefferson Ave								Riley St								Jefferson Ave								Riley St								Total
	Southbound				Westbound				Northbound				Eastbound				Southbound				Westbound				Northbound				Eastbound				
Start Time	Right	Thru	Left	U-Turn	App Total	Peds CW	Peds CCW		Right	Thru	Left	U-Turn	App Total	Peds CW	Peds CCW		Right	Thru	Left	U-Turn	App Total	Peds CW	Peds CCW		Right	Thru	Left	U-Turn	App Total	Peds CW	Peds CCW		
4:15:00 PM	1	68	2	0	71	1	6		4	4	4	0	12	0	1		9	79	1	0	89	0	0		1	8	2	0	11	0	0		183
4:30:00 PM	9	81	5	0	95	0	1		4	3	4	0	11	2	2		12	60	0	0	72	0	0		5	7	4	0	16	0	0		194
4:45:00 PM	3	54	2	0	59	0	0		3	6	5	0	14	0	2		7	72	1	0	80	0	1		1	5	2	0	8	1	0		161
5:00:00 PM	4	79	1	0	84	0	0		5	6	2	0	13	0	1		8	60	4	0	72	0	1		3	6	3	0	12	2	2		202
Grand Total	17	282	10	0	299	1	7		16	19	15	0	39	2	6		37	291	6	0	334	0	2		10	26	11	0	47	3	2		740
% Approach	5.5%	91.3%	3.2%	0.0%	0.0%	0.0%	0.0%		32.0%	38.0%	30.0%	0.0%	0.0%	0.0%	0.0%		11.1%	87.1%	1.8%	0.0%	0.0%	0.0%	0.0%		21.3%	55.3%	23.4%	0.0%	0.0%	0.0%	0.0%		
% Total	2.3%	38.1%	1.4%	0.0%	41.8%	0.0%	0.0%		2.2%	2.6%	2.0%	0.0%	6.8%	0.0%	0.0%		5.0%	39.3%	0.8%	0.0%	45.1%	0.0%	0.0%		1.4%	3.5%	1.5%	0.0%	6.4%	0.0%	0.0%		
PHF	0.472	0.870	0.500	0.000	0.813	0.000	0.000		0.800	0.792	0.750	0.000	0.893	0.000	0.000		0.771	0.909	0.375	0.000	0.898	0.000	0.000		0.500	0.813	0.688	0.000	0.734	0.000	0.000		
Lights	16	271	8	0	295	0	0		15	18	15	0	48	0	0		36	286	5	0	327	0	0		10	24	9	0	43	0	0		
% Lights	84.1%	96.1%	80.0%	0.0%	95.5%	0.0%	0.0%		83.8%	94.7%	100.0%	0.0%	96.0%	0.0%	0.0%		87.3%	98.3%	83.3%	0.0%	97.9%	0.0%	0.0%		100.0%	92.3%	81.8%	0.0%	91.5%	0.0%	0.0%		
Trucks	0	0	0	0	0	0	0		0	0	0	0	0	0	0		0	0	0	0	0	0	0		0	0	0	0	0	0	0		
% Trucks	0.0%	0.0%	0.0%	0.0%	0.0%	0.0%	0.0%		0.0%	0.0%	0.0%	0.0%	0.0%	0.0%	0.0%		0.0%	0.0%	0.0%	0.0%	0.0%	0.0%	0.0%		0.0%	0.0%	0.0%	0.0%	0.0%	0.0%	0.0%		
Buses	1	11	2	0	14	0	0		1	1	0	0	2	0	0		1	5	1	0	7	0	0		0	2	2	0	4	0	0		
% Buses	5.9%	3.9%	20.0%	0.0%	0.0%	0.0%	0.0%		6.3%	5.3%	0.0%	0.0%	0.0%	0.0%	0.0%		2.7%	1.7%	16.7%	0.0%	0.0%	0.0%	0.0%		0.0%	7.7%	18.2%	0.0%	0.0%	0.0%	0.0%		
Pedestrians	0	0	0	0	0	1	7		0	0	0	0	2	6	0		0	0	0	0	0	0	2	0	0	0	0	0	0	3	1		
% Pedestrians	0.0%	0.0%	0.0%	0.0%	0.0%	100.0%	100.0%		0.0%	0.0%	0.0%	0.0%	0.0%	100.0%	100.0%		0.0%	0.0%	0.0%	0.0%	0.0%	0.0%	100.0%		0.0%	0.0%	0.0%	0.0%	0.0%	100.0%	50.0%		
Bicycles on Crosswalk	0	0	0	0	0	0	0		0	0	0	0	0	0	0		0	0	0	0	0	0	0		0	0	0	0	0	0	1		
% Bicycles on Crosswalk	0.0%	0.0%	0.0%	0.0%	0.0%	0.0%	0.0%		0.0%	0.0%	0.0%	0.0%	0.0%	0.0%	0.0%		0.0%	0.0%	0.0%	0.0%	0.0%	0.0%	0.0%		0.0%	0.0%	0.0%	0.0%	0.0%	0.0%	50.0%		

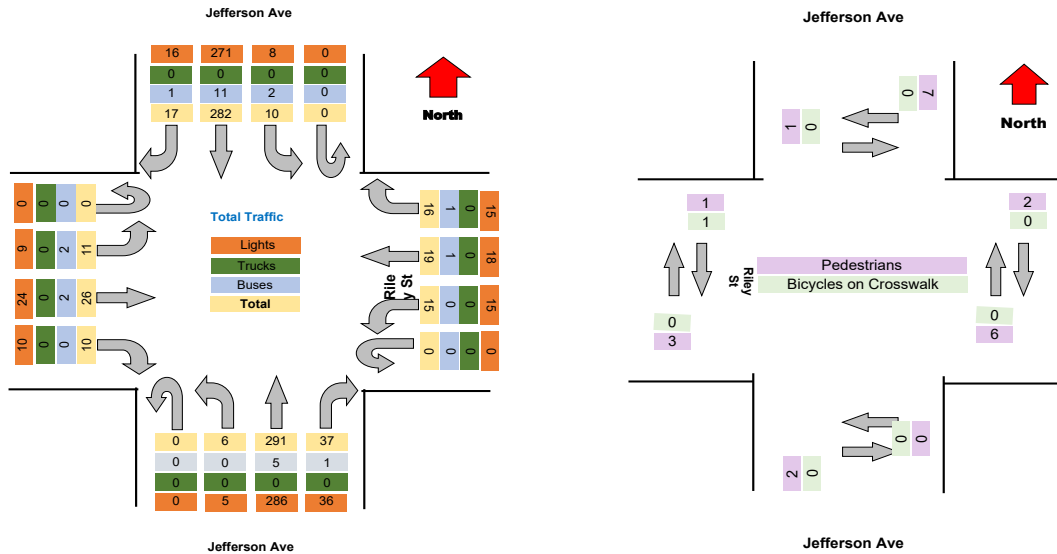

Project : VBH Malta NY
 Site : Site 4
 Location : 42.948550, -73.790036
 Survey Date : 2021-04-28, Wednesday

Turning Movement Data Plot

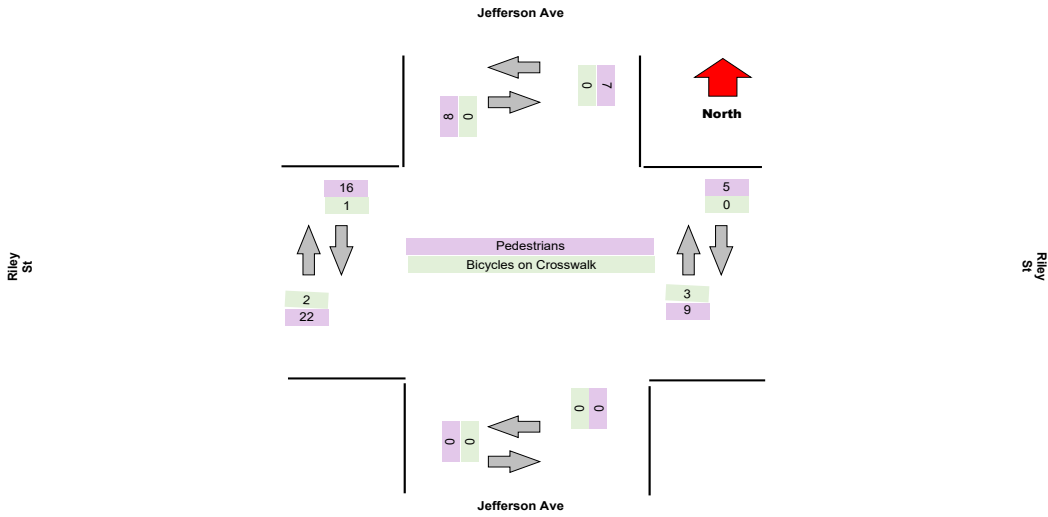
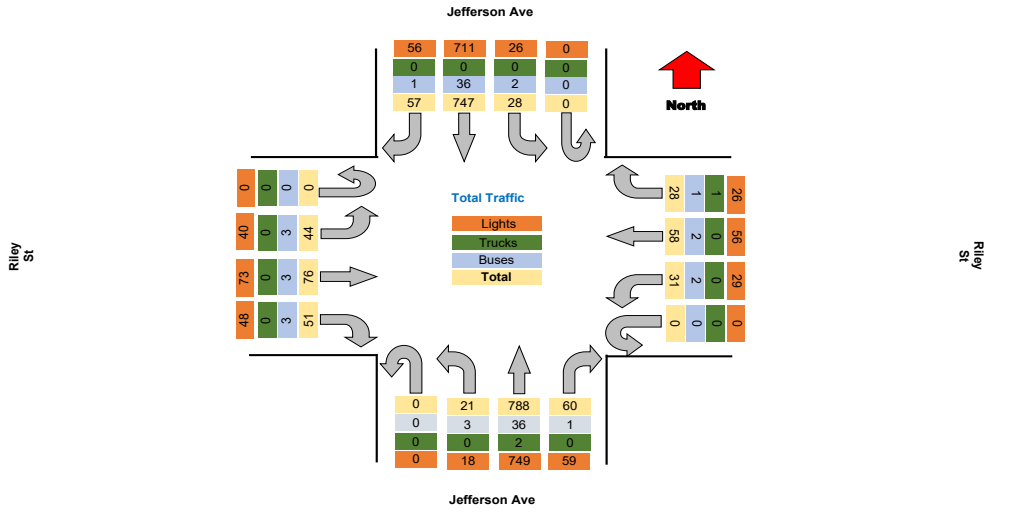

Turning Movement Peak Hour Data (AM)

7:30:00 AM

Leg Direction	Jefferson Ave				Riley St				Jefferson Ave				Riley St				Total													
	Southbound		Northbound		Westbound		Eastbound		Northbound		Eastbound		Westbound		Eastbound															
Start Time	Right	Thru	Left	U-Turn	App Total	Peds CW	Peds CCW	Right	Thru	Left	U-Turn	App Total	Peds CW	Peds CCW	Right	Thru	Left	U-Turn	App Total	Peds CW	Peds CCW									
7:30:00 AM	1	42	0	0	43	0	0	1	2	0	0	3	1	1	2	29	1	0	34	0	0	92								
7:45:00 AM	0	39	1	0	40	4	1	3	4	3	0	11	0	0	0	47	3	0	50	0	0	107								
8:00:00 AM	4	44	1	0	49	0	1	1	4	1	0	7	1	0	1	40	1	0	43	0	0	111								
8:15:00 AM	4	39	1	0	44	0	0	0	5	0	0	5	0	0	4	47	1	0	53	0	0	118								
Grand Total	9	164	3	0	176	4	2	5	15	4	0	25	2	2	7	153	6	0	160	0	0	428								
% Approach	5.1%	93.2%	1.7%	0.0%	0.0%	0.0%	0.0%	19.2%	57.7%	15.4%	0.0%	0.0%	0.0%	0.0%	3.9%	90.6%	3.3%	0.0%	0.0%	0.0%	0.0%	37.0%	43.5%	19.6%	0.0%	0.0%	0.0%			
% Total	2.1%	38.3%	0.7%	0.0%	41.1%	0.0%	0.0%	1.2%	3.5%	0.9%	0.0%	6.1%	0.0%	0.0%	1.6%	38.1%	1.4%	0.0%	42.1%	0.0%	0.0%	4.0%	4.7%	2.1%	0.0%	10.7%	0.0%	0.0%		
PHF	0.563	0.932	0.750	0.000	0.898	0.000	0.000	0.417	0.750	0.333	0.000	0.591	0.000	0.000	0.438	0.867	0.500	0.000	0.849	0.000	0.000	0.607	0.500	0.563	0.000	0.719	0.000	0.000		
Lights	9	154	3	0	166	0	0	3	14	3	0	20	0	0	7	146	5	0	158	0	0	15	19	9	0	43	0	0	387	
% Lights	100.0%	93.9%	100.0%	0.0%	94.3%	0.0%	0.0%	60.0%	93.3%	75.0%	0.0%	76.9%	0.0%	0.0%	100.0%	89.6%	83.3%	0.0%	87.8%	0.0%	0.0%	88.2%	95.0%	100.0%	0.0%	93.5%	0.0%	0.0%	90.4%	
Trucks	0	0	0	0	0	0	0	1	0	0	0	1	0	0	0	1	0	0	1	0	0	0	0	0	0	0	0	0	2	
% Trucks	0.0%	0.0%	0.0%	0.0%	0.0%	0.0%	0.0%	20.0%	0.0%	0.0%	0.0%	3.8%	0.0%	0.0%	0.0%	0.6%	0.0%	0.0%	0.6%	0.0%	0.0%	0.0%	0.0%	0.0%	0.0%	0.0%	0.0%	0.0%	0.5%	
Buses	0	10	0	0	10	0	0	1	1	1	0	3	0	0	0	16	1	0	17	0	0	2	1	0	0	3	0	0	33	
% Buses	0.0%	6.1%	0.0%	0.0%	0.0%	0.0%	0.0%	20.0%	6.7%	25.0%	0.0%	0.0%	0.0%	0.0%	0.0%	9.8%	16.7%	0.0%	0.0%	0.0%	0.0%	11.8%	5.0%	0.0%	0.0%	0.0%	0.0%	0.0%	7.7%	
Pedestrians	0	0	0	0	0	4	2	0	0	0	0	0	2	1	0	0	0	0	0	0	0	0	0	0	0	0	0	7	2	0
% Pedestrians	0.0%	0.0%	0.0%	0.0%	0.0%	100.0%	100.0%	0.0%	0.0%	0.0%	0.0%	0.0%	100.0%	50.0%	0.0%	0.0%	0.0%	0.0%	0.0%	0.0%	0.0%	0.0%	0.0%	0.0%	0.0%	0.0%	0.0%	87.5%	100.0%	0.0%
Bicycles on Crosswalk	0	0	0	0	0	0	0	0	0	0	0	0	1	0	0	0	0	0	0	0	0	0	0	0	0	0	0	1	0	0
% Bicycles on Crosswalk	0.0%	0.0%	0.0%	0.0%	0.0%	0.0%	0.0%	0.0%	0.0%	0.0%	0.0%	0.0%	0.0%	50.0%	0.0%	0.0%	0.0%	0.0%	0.0%	0.0%	0.0%	0.0%	0.0%	0.0%	0.0%	0.0%	0.0%	12.5%	0.0%	0.0%

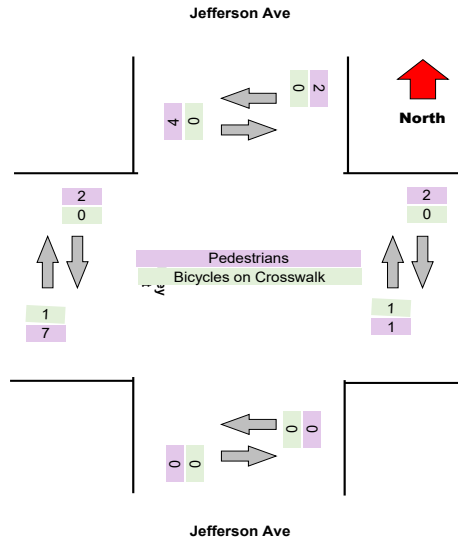
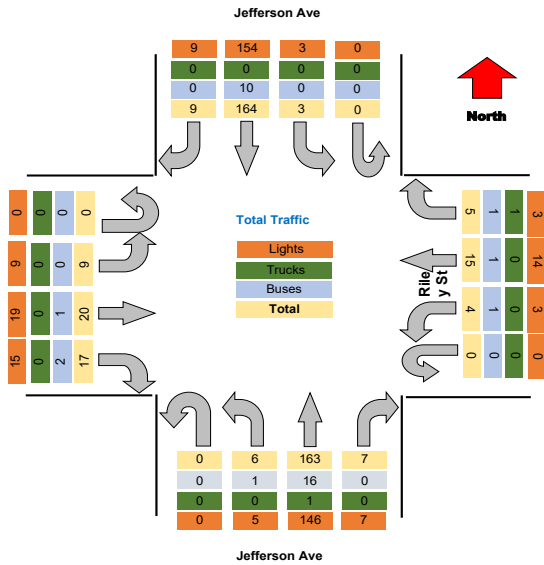

Turning Movement Peak Hour Data (PM)

4:15:00 PM

Leg Direction	Jefferson Ave				Riley St				Jefferson Ave				Riley St				Total													
	Southbound				Westbound				Northbound				Eastbound																	
	Right	Thru	Left	U-Turn	App Total	Peds CW	Peds CCW	Right	Thru	Left	U-Turn	App Total	Peds CW	Peds CCW	Right	Thru		Left	U-Turn	App Total	Peds CW	Peds CCW								
4:15:00 PM	5	72	2	0	79	1	1	3	6	7	0	16	0	3	10	71	0	0	81	0	0	5	11	1	0	17	4	2	193	
4:30:00 PM	4	60	4	0	68	0	2	4	3	0	0	7	1	2	7	66	1	0	74	0	0	3	6	1	0	10	1	1	159	
4:45:00 PM	7	65	1	0	73	1	1	1	1	3	0	5	1	0	6	77	3	0	86	0	0	1	4	8	0	13	1	2	177	
5:00:00 PM	5	70	8	0	83	0	0	3	7	1	0	11	0	0	6	65	4	0	75	0	0	2	7	5	0	14	1	2	183	
Grand Total	21	267	15	0	303	2	4	11	17	11	0	39	2	5	29	279	8	0	316	0	0	11	28	15	0	54	7	7	712	
% Approach	6.9%	88.1%	5.0%	0.0%	0.0%	0.0%	0.0%	28.2%	43.6%	28.2%	0.0%	0.0%	0.0%	0.0%	9.2%	88.3%	2.5%	0.0%	0.0%	0.0%	0.0%	20.4%	51.9%	27.8%	0.0%	0.0%	0.0%	0.0%	0.0%	
% Total	2.9%	37.5%	2.1%	0.0%	42.6%	0.0%	0.0%	1.5%	2.4%	1.5%	0.0%	5.5%	0.0%	0.0%	4.1%	39.2%	1.1%	0.0%	44.4%	0.0%	0.0%	1.5%	3.9%	2.1%	0.0%	7.6%	0.0%	0.0%	0.0%	
PHF	0.750	0.927	0.469	0.000	0.913	0.000	0.000	0.688	0.607	0.393	0.000	0.609	0.000	0.000	0.725	0.906	0.500	0.000	0.919	0.000	0.000	0.550	0.636	0.469	0.000	0.794	0.000	0.000	0.922	
Lights	20	258	14	0	292	0	0	11	16	11	0	38	0	0	28	270	7	0	305	0	0	10	27	12	0	49	0	0	684	
% Lights	65.2%	96.6%	93.3%	0.0%	96.4%	0.0%	0.0%	100.0%	94.1%	100.0%	0.0%	97.4%	0.0%	0.0%	96.6%	96.8%	87.5%	0.0%	96.5%	0.0%	0.0%	90.9%	96.4%	80.0%	0.0%	90.7%	0.0%	0.0%	96.1%	
Trucks	0	0	0	0	0	0	0	0	0	0	0	0	0	0	0	0	0	0	0	0	0	0	0	0	0	0	0	0	0	
% Trucks	0.0%	0.0%	0.0%	0.0%	0.0%	0.0%	0.0%	0.0%	0.0%	0.0%	0.0%	0.0%	0.0%	0.0%	0.0%	0.0%	0.0%	0.0%	0.0%	0.0%	0.0%	0.0%	0.0%	0.0%	0.0%	0.0%	0.0%	0.0%	0.0%	
Buses	1	9	1	0	11	0	0	0	1	0	0	1	0	0	1	8	1	0	10	0	0	1	1	3	0	5	0	0	27	
% Buses	4.8%	3.4%	6.7%	0.0%	0.0%	0.0%	0.0%	0.0%	5.9%	0.0%	0.0%	0.0%	0.0%	0.0%	3.4%	2.9%	12.5%	0.0%	0.0%	0.0%	0.0%	9.1%	3.8%	20.0%	0.0%	0.0%	0.0%	0.0%	3.8%	
Pedestrians	0	0	0	0	0	2	4	0	0	0	0	2	4	0	0	0	0	0	0	0	0	0	0	0	0	0	6	6	0	
% Pedestrians	0.0%	0.0%	0.0%	0.0%	0.0%	100.0%	100.0%	0.0%	0.0%	0.0%	0.0%	0.0%	100.0%	80.0%	0.0%	0.0%	0.0%	0.0%	0.0%	0.0%	0.0%	0.0%	0.0%	0.0%	0.0%	0.0%	0.0%	85.7%	85.7%	0.0%
Bicycles on Crosswalk	0	0	0	0	0	0	0	0	0	0	0	1	0	0	0	0	0	0	0	0	0	0	0	0	0	0	1	1	0	
% Bicycles on Crosswalk	0.0%	0.0%	0.0%	0.0%	0.0%	0.0%	0.0%	0.0%	0.0%	0.0%	0.0%	0.0%	0.0%	20.0%	0.0%	0.0%	0.0%	0.0%	0.0%	0.0%	0.0%	0.0%	0.0%	0.0%	0.0%	0.0%	14.3%	14.3%	0.0%	

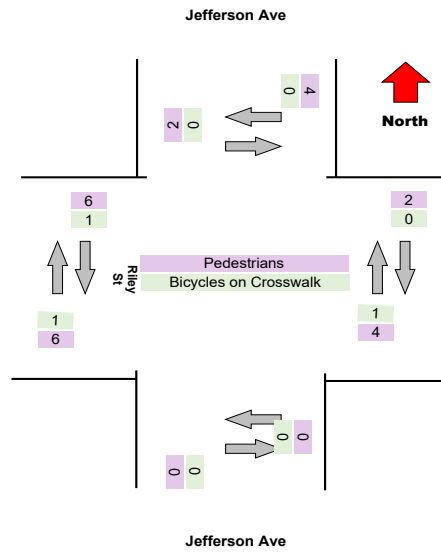
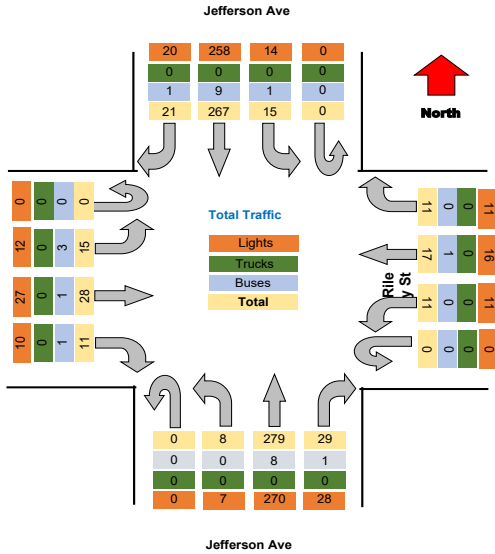

Project : VBH Malta NY
 Site : Site 4
 Location : 42.948550, -73.790036
 Survey Date : 2021-04-28, Wednesday

Turning Movement Data Plot

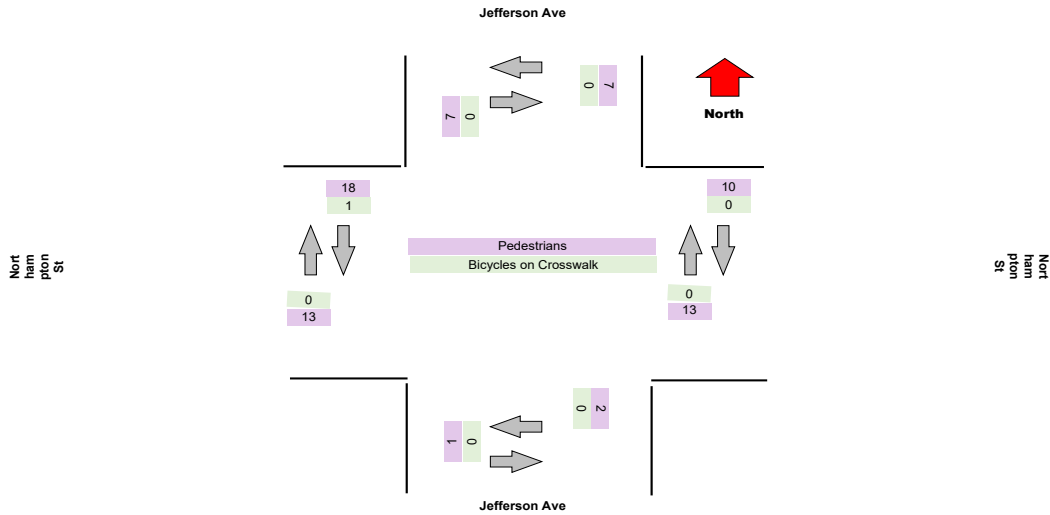
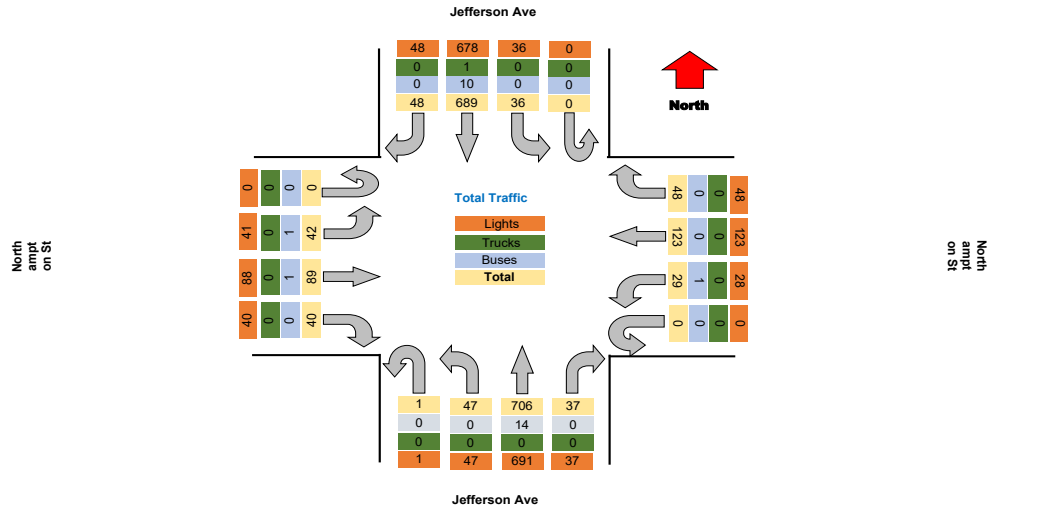

Project : VBH Malta NY
Site : Site 4
Location : 42.948550, -73.790036
Survey Date : 2021-04-28, Wednesday

TSTData.com

Turning Movement Peak Hour Data (AM)

7:30:00 AM

Leg Direction	Jefferson Ave						Northampton St						Jefferson Ave						Northampton St						Total					
	Southbound			Northbound			Westbound			Eastbound			Northbound			Eastbound														
Start Time	Right	Thru	Left	U-Turn	App Total	Peds CW	Peds CCW	Right	Thru	Left	U-Turn	App Total	Peds CW	Peds CCW	Right	Thru	Left	U-Turn	App Total	Peds CW	Peds CCW	Right	Thru	Left	U-Turn	App Total	Peds CW	Peds CCW		
7:30:00 AM	3	21	0	0	24	0	0	1	5	2	0	8	0	1	1	24	4	0	0	30	0	0	1	4	0	0	5	2	0	67
7:45:00 AM	0	25	3	0	28	0	0	1	8	0	0	9	0	0	2	26	4	0	0	32	0	0	4	3	1	0	8	0	2	77
8:00:00 AM	1	32	2	0	35	0	0	3	13	1	0	17	1	0	2	31	4	0	0	38	0	0	2	3	1	0	6	0	1	96
8:15:00 AM	4	44	3	0	48	0	0	5	13	1	0	20	0	0	1	23	3	0	0	29	1	0	3	6	1	0	10	0	0	108
Grand Total	8	117	8	0	135	0	0	10	39	4	0	54	1	0	6	104	15	0	128	1	0	10	16	3	0	29	2	3	348	
% Approach	5.9%	88.1%	5.9%	0.0%	0.0%	0.0%	0.0%	18.5%	72.2%	7.4%	0.0%	0.0%	0.0%	0.0%	4.7%	81.3%	11.7%	0.0%	0.0%	0.0%	0.0%	34.5%	55.2%	10.3%	0.0%	0.0%	0.0%	0.0%	0.0%	
% Total	2.3%	34.4%	2.3%	0.0%	38.0%	0.0%	0.0%	2.9%	11.3%	1.2%	0.0%	15.6%	0.0%	0.0%	1.7%	30.1%	4.3%	0.0%	37.0%	0.0%	0.0%	2.9%	4.6%	0.9%	0.0%	8.4%	0.0%	0.0%	0.0%	
PHF	0.500	0.728	0.667	0.000	0.703	0.000	0.000	0.500	0.750	0.500	0.000	0.675	0.000	0.000	0.750	0.839	0.938	0.000	0.842	0.000	0.000	0.625	0.667	0.750	0.000	0.725	0.000	0.000	0.816	
Lights	8	117	8	0	133	0	0	10	39	4	0	53	0	0	6	100	15	0	121	0	0	10	15	2	0	27	0	0	334	
% Lights	100.0%	98.3%	100.0%	0.0%	98.5%	0.0%	0.0%	100.0%	100.0%	100.0%	0.0%	98.1%	0.0%	0.0%	100.0%	96.2%	100.0%	0.0%	94.5%	0.0%	0.0%	100.0%	93.8%	66.7%	0.0%	93.1%	0.0%	0.0%	96.5%	
Trucks	0	0	0	0	0	0	0	0	0	0	0	0	0	0	0	0	0	0	0	0	0	0	0	0	0	0	0	0	0	0
% Trucks	0.0%	0.0%	0.0%	0.0%	0.0%	0.0%	0.0%	0.0%	0.0%	0.0%	0.0%	0.0%	0.0%	0.0%	0.0%	0.0%	0.0%	0.0%	0.0%	0.0%	0.0%	0.0%	0.0%	0.0%	0.0%	0.0%	0.0%	0.0%	0.0%	
Buses	0	2	0	0	2	0	0	0	0	0	0	0	0	0	0	4	0	0	4	0	0	0	1	1	0	2	0	0	8	
% Buses	0.0%	1.7%	0.0%	0.0%	0.0%	0.0%	0.0%	0.0%	0.0%	0.0%	0.0%	0.0%	0.0%	0.0%	0.0%	3.8%	0.0%	0.0%	0.0%	0.0%	0.0%	0.0%	6.3%	33.3%	0.0%	0.0%	0.0%	0.0%	2.3%	
Pedestrians	0	0	0	0	0	0	0	0	0	0	0	1	2	0	0	0	0	0	0	1	0	0	0	0	0	0	2	3	0	
% Pedestrians	0.0%	0.0%	0.0%	0.0%	0.0%	0.0%	100.0%	0.0%	0.0%	0.0%	0.0%	0.0%	100.0%	100.0%	0.0%	0.0%	0.0%	0.0%	0.0%	100.0%	0.0%	0.0%	0.0%	0.0%	0.0%	0.0%	100.0%	100.0%	0.0%	
Bicycles on Crosswalk	0	0	0	0	0	0	0	0	0	0	0	0	0	0	0	0	0	0	0	0	0	0	0	0	0	0	0	0	0	
% Bicycles on Crosswalk	0.0%	0.0%	0.0%	0.0%	0.0%	0.0%	0.0%	0.0%	0.0%	0.0%	0.0%	0.0%	0.0%	0.0%	0.0%	0.0%	0.0%	0.0%	0.0%	0.0%	0.0%	0.0%	0.0%	0.0%	0.0%	0.0%	0.0%	0.0%	0.0%	

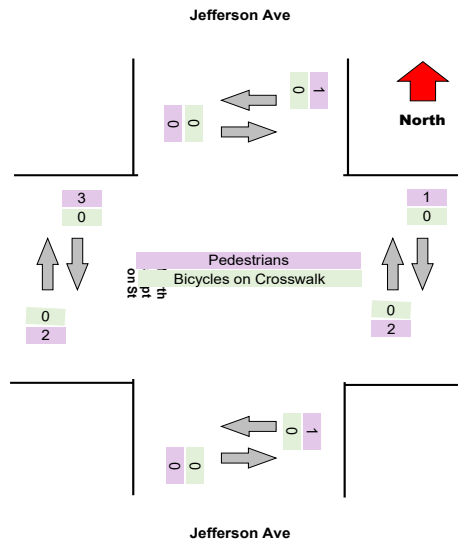
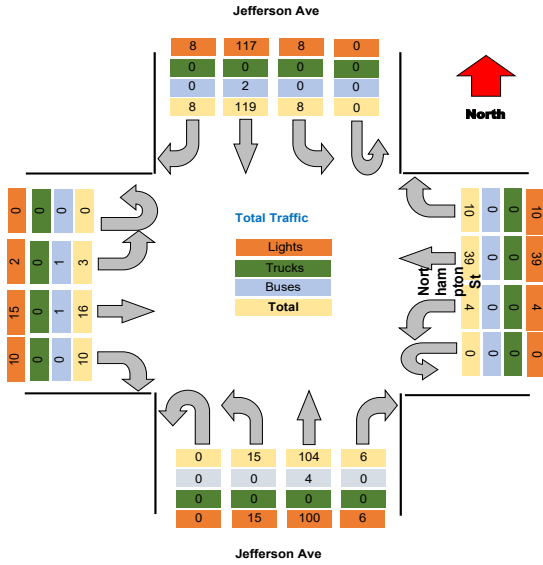

Turning Movement Peak Hour Data (PM)

4:15:00 PM

Leg Direction	Jefferson Ave								Northampton St								Jefferson Ave								Northampton St								Total
	Southbound				Westbound				Northbound				Eastbound				Southbound				Westbound				Northbound				Eastbound				
	Right	Thru	Left	U-Turn	App Total	Peds CW	Peds CCW		Right	Thru	Left	U-Turn	App Total	Peds CW	Peds CCW		Right	Thru	Left	U-Turn	App Total	Peds CW	Peds CCW		Right	Thru	Left	U-Turn	App Total	Peds CW	Peds CCW		
4:15:00 PM	4	64	2	0	70	0	1		8	9	2	0	19	0	1		2	50	3	0	55	0	0		4	11	8	0	23	0	0		167
4:30:00 PM	3	72	4	0	79	3	0		11	4	2	0	17	2	1		2	68	4	0	74	0	0		3	7	4	0	14	1	2		184
4:45:00 PM	5	59	4	0	68	0	2		2	11	5	0	18	0	3		4	70	6	0	80	1	0		3	13	4	0	20	1	1		186
5:00:00 PM	4	49	4	0	57	0	0		4	14	3	0	21	2	2		7	79	3	0	89	0	1		4	6	5	0	15	0	1		182
Grand Total	16	244	14	0	274	0	0		25	38	12	0	75	0	7		15	287	16	0	298	1	1		14	37	21	0	72	2	4		719
% Approach	5.8%	89.1%	5.1%	0.0%	0.0%	0.0%	0.0%		33.3%	50.7%	16.0%	0.0%	0.0%	0.0%	0.0%		5.0%	89.6%	5.4%	0.0%	0.0%	0.0%	0.0%		19.4%	51.4%	29.2%	0.0%	0.0%	0.0%	0.0%		
% Total	2.2%	33.9%	1.9%	0.0%	38.1%	0.0%	0.0%		3.5%	5.3%	1.7%	0.0%	10.4%	0.0%	0.0%		2.1%	37.1%	2.2%	0.0%	41.4%	0.0%	0.0%		1.9%	5.1%	2.9%	0.0%	10.0%	0.0%	0.0%		
PHF	0.800	0.847	0.875	0.000	0.867	0.000	0.000		0.568	0.679	0.600	0.000	0.893	0.000	0.000		0.536	0.845	0.667	0.000	0.837	0.000	0.000		0.875	0.712	0.656	0.000	0.783	0.000	0.000		0.966
Lights	16	240	14	0	270	0	0		25	38	11	0	74	0	0		15	261	16	0	292	0	0		14	37	21	0	72	0	0		708
% Lights	100.0%	98.4%	100.0%	0.0%	98.5%	0.0%	0.0%		100.0%	100.0%	91.7%	0.0%	98.7%	0.0%	0.0%		100.0%	97.8%	100.0%	0.0%	98.0%	0.0%	0.0%		100.0%	100.0%	100.0%	0.0%	100.0%	0.0%	0.0%		98.5%
Trucks	0	1	0	0	1	0	0		0	0	0	0	0	0	0		0	0	0	0	0	0	0		0	0	0	0	0	0	0		1
% Trucks	0.0%	0.4%	0.0%	0.0%	0.4%	0.0%	0.0%		0.0%	0.0%	0.0%	0.0%	0.0%	0.0%	0.0%		0.0%	0.0%	0.0%	0.0%	0.0%	0.0%	0.0%		0.0%	0.0%	0.0%	0.0%	0.0%	0.0%	0.0%		0.1%
Buses	0	3	0	0	3	0	0		0	0	1	0	1	0	0		0	5	0	0	5	0	0		0	0	0	0	0	0	0		9
% Buses	0.0%	1.2%	0.0%	0.0%	0.0%	0.0%	0.0%		0.0%	0.0%	8.3%	0.0%	0.0%	0.0%	0.0%		0.0%	1.9%	0.0%	0.0%	0.0%	0.0%	0.0%		0.0%	0.0%	0.0%	0.0%	0.0%	0.0%	0.0%		1.3%
Pedestrians	0	0	0	0	0	4	3		0	0	0	0	0	4	7		0	0	0	0	0	1	1		0	0	0	0	0	2	4		0
% Pedestrians	0.0%	0.0%	0.0%	0.0%	0.0%	100.0%	100.0%		0.0%	0.0%	0.0%	0.0%	0.0%	100.0%	100.0%		0.0%	0.0%	0.0%	0.0%	0.0%	100.0%	100.0%		0.0%	0.0%	0.0%	0.0%	0.0%	100.0%	100.0%		0.0%
Bicycles on Crosswalk	0	0	0	0	0	0	0		0	0	0	0	0	0	0		0	0	0	0	0	0	0		0	0	0	0	0	0	0		0
% Bicycles on Crosswalk	0.0%	0.0%	0.0%	0.0%	0.0%	0.0%	0.0%		0.0%	0.0%	0.0%	0.0%	0.0%	0.0%	0.0%		0.0%	0.0%	0.0%	0.0%	0.0%	0.0%	0.0%		0.0%	0.0%	0.0%	0.0%	0.0%	0.0%	0.0%		0.0%

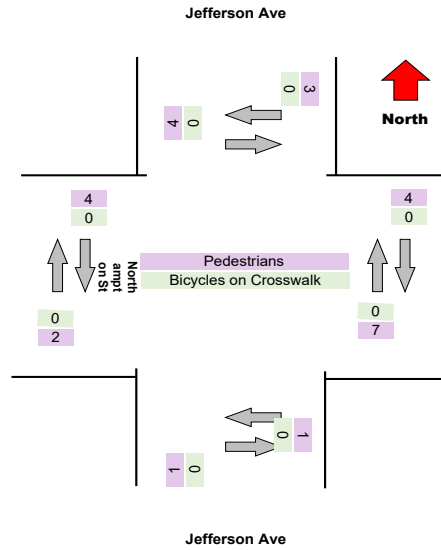
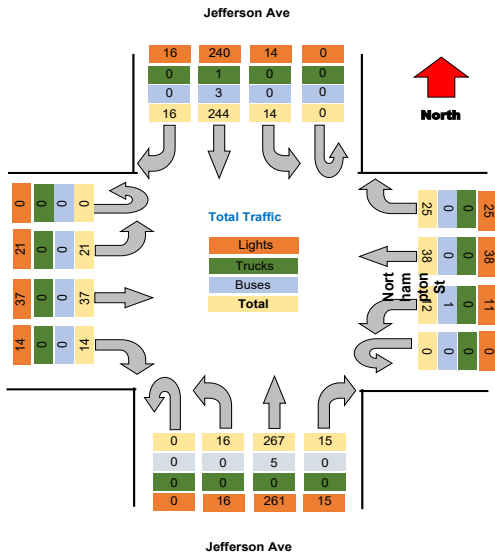

Project : VBH Malta NY
 Site : Site 4
 Location : 42.948550, -73.790036
 Survey Date : 2021-04-28, Wednesday

Turning Movement Data Plot

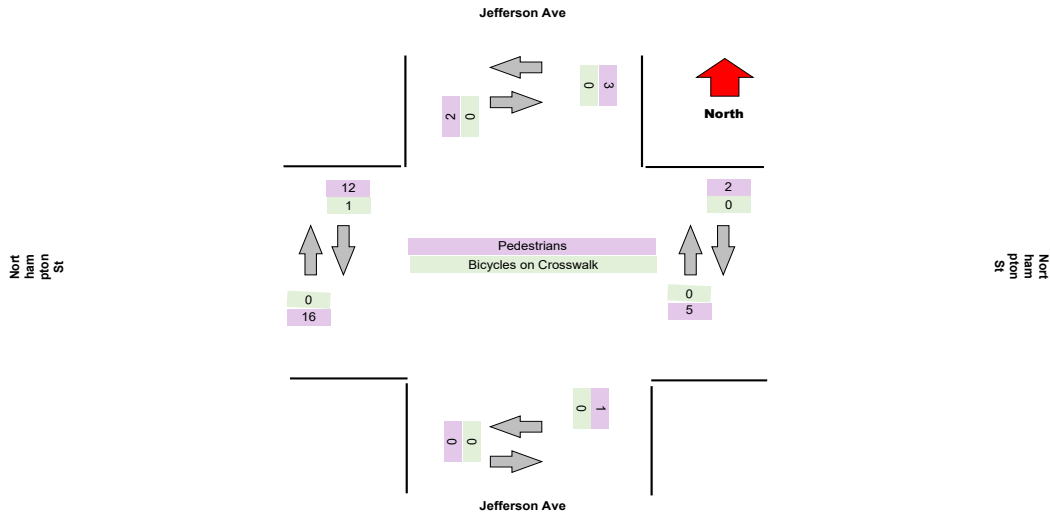
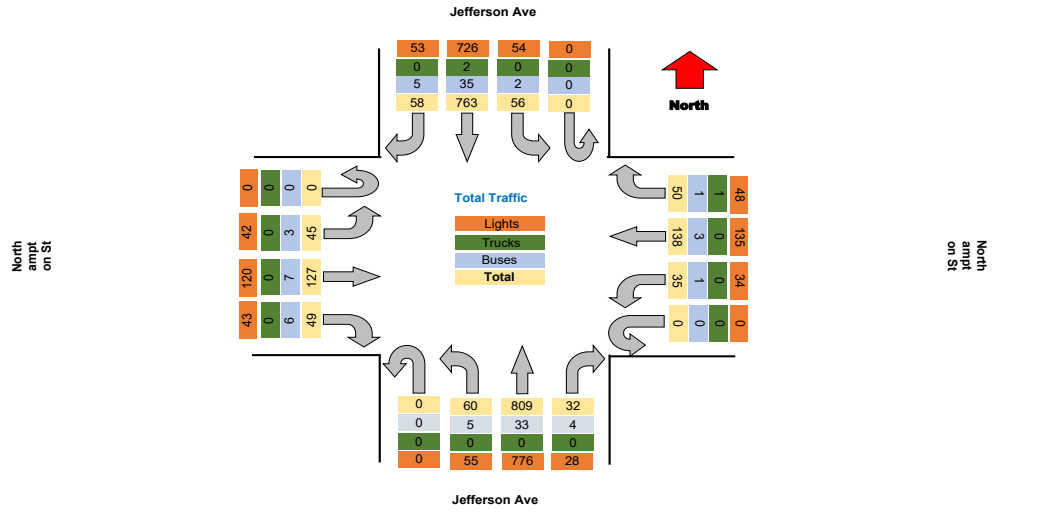

Project : VBH Malta NY
Site : Site 4
Location : 42.948550, -73.790036

TSTData.com

Survey Date : 2021-04-28, Wednesday

Turning Movement Peak Hour Data (AM)

7:30:00 AM

Leg Direction	Jefferson Ave					Northampton St					Jefferson Ave					Northampton St					Total									
	Right	Thru	Left	U-Turn	App Total	Peds CW	Peds CCW	Right	Thru	Left	U-Turn	App Total	Peds CW	Peds CCW	Right	Thru	Left	U-Turn	App Total	Peds CW		Peds CCW								
7:30:00 AM	4	36	0	0	40	0	0	1	7	5	0	14	0	0	0	32	3	0	35	0	0	10	1	0	99					
7:45:00 AM	3	60	3	0	66	0	0	0	15	4	0	19	0	0	2	40	1	0	43	0	0	1	9	0	10	4	0	138		
8:00:00 AM	2	56	1	0	59	0	0	4	14	1	0	19	0	1	2	41	4	0	48	0	0	4	8	0	14	0	1	140		
8:15:00 AM	2	33	2	0	37	0	0	4	19	2	0	24	0	0	0	42	5	0	47	0	0	4	8	0	12	2	1	120		
Grand Total	11	185	6	0	202	0	0	9	54	12	0	75	0	1	4	155	13	0	173	0	0	6	34	8	46	7	2	497		
% Approach	5.4%	91.6%	3.0%	0.0%	0.0%	0.0%	0.0%	11.8%	71.1%	15.8%	0.0%	0.0%	0.0%	0.0%	2.3%	89.6%	7.5%	0.0%	0.0%	0.0%	0.0%	13.0%	73.9%	13.0%	0.0%	0.0%	0.0%	0.0%		
% Total	2.2%	37.2%	1.2%	0.0%	46.6%	0.0%	0.0%	1.8%	10.9%	2.4%	0.0%	15.3%	0.0%	0.0%	0.8%	31.2%	2.6%	0.0%	34.8%	0.0%	0.0%	1.2%	6.8%	1.2%	0.0%	9.3%	0.0%	0.0%		
PHF	0.688	0.771	0.500	0.000	0.765	0.000	0.000	0.563	0.750	0.600	0.000	0.792	0.000	0.000	0.500	0.923	0.650	0.000	0.801	0.000	0.000	0.375	0.944	0.375	0.000	0.821	0.000	0.000	0.888	
Lights	8	171	5	0	184	0	0	9	53	11	0	73	0	0	4	139	11	0	154	0	0	6	31	5	0	42	0	0	463	
% Lights	72.7%	92.4%	83.3%	0.0%	91.1%	0.0%	0.0%	100.0%	98.1%	91.7%	0.0%	96.1%	0.0%	0.0%	100.0%	89.7%	84.6%	0.0%	89.0%	0.0%	0.0%	100.0%	91.2%	83.3%	0.0%	91.3%	0.0%	0.0%	91.1%	
Trucks	0	1	0	0	1	0	0	0	0	0	0	0	0	0	0	0	0	0	0	0	0	0	0	0	0	0	0	0	1	
% Trucks	0.0%	0.5%	0.0%	0.0%	0.5%	0.0%	0.0%	0.0%	0.0%	0.0%	0.0%	0.0%	0.0%	0.0%	0.0%	0.0%	0.0%	0.0%	0.0%	0.0%	0.0%	0.0%	0.0%	0.0%	0.0%	0.0%	0.0%	0.0%	0.2%	
Buses	3	13	1	0	17	0	0	0	1	1	0	2	0	0	0	16	2	0	18	0	0	0	3	1	0	4	0	0	41	
% Buses	27.3%	7.0%	16.7%	0.0%	0.0%	0.0%	0.0%	0.0%	1.9%	8.3%	0.0%	0.0%	0.0%	0.0%	0.0%	10.3%	15.4%	0.0%	0.0%	0.0%	0.0%	0.0%	8.8%	16.7%	0.0%	0.0%	0.0%	0.0%	8.2%	
Pedestrians	0	0	0	0	0	0	0	0	0	0	0	0	0	0	0	0	0	0	0	0	0	0	0	0	0	0	7	2	0	
% Pedestrians	0.0%	0.0%	0.0%	0.0%	0.0%	0.0%	100.0%	0.0%	0.0%	0.0%	0.0%	0.0%	0.0%	0.0%	0.0%	0.0%	0.0%	0.0%	0.0%	0.0%	0.0%	0.0%	0.0%	0.0%	0.0%	0.0%	0.0%	100.0%	100.0%	0.0%
Bicycles on Crosswalk	0	0	0	0	0	0	0	0	0	0	0	0	0	0	0	0	0	0	0	0	0	0	0	0	0	0	0	0	0	
% Bicycles on Crosswalk	0.0%	0.0%	0.0%	0.0%	0.0%	0.0%	0.0%	0.0%	0.0%	0.0%	0.0%	0.0%	0.0%	0.0%	0.0%	0.0%	0.0%	0.0%	0.0%	0.0%	0.0%	0.0%	0.0%	0.0%	0.0%	0.0%	0.0%	0.0%	0.0%	

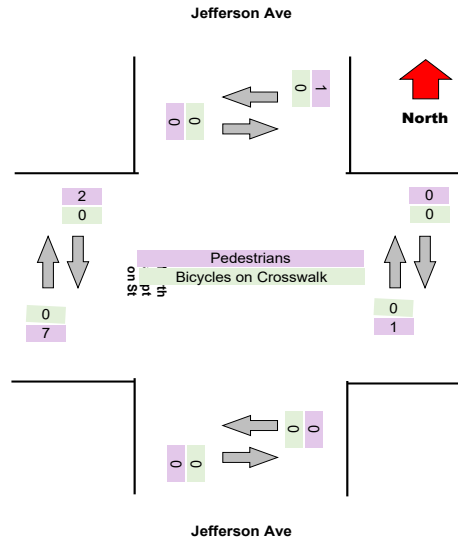
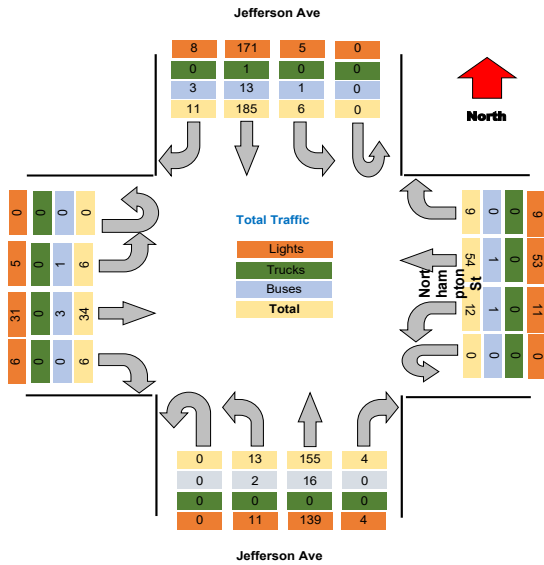

Turning Movement Peak Hour Data (PM)

4:15:00 PM

Leg Direction	Jefferson Ave								Northampton St								Jefferson Ave								Northampton St								Total
	Southbound				Northbound				Westbound				Eastbound				Northbound				Eastbound												
	Right	Thru	Left	U-Turn	App Total	Peds CW	Peds CCW		Right	Thru	Left	U-Turn	App Total	Peds CW	Peds CCW		Right	Thru	Left	U-Turn	App Total	Peds CW	Peds CCW		Right	Thru	Left	U-Turn	App Total	Peds CW	Peds CCW		
4:15:00 PM	6	63	9	0	78	0	0		5	12	1	0	18	0	0		4	72	3	0	79	0	0		6	5	5	0	16	0	0		191
4:30:00 PM	7	77	7	0	91	0	1		5	6	6	0	17	0	1		3	59	3	0	65	0	0		8	14	3	0	25	0	1		198
4:45:00 PM	7	47	4	0	58	0	0		4	10	3	0	17	2	1		2	79	7	0	79	0	0		2	10	5	0	17	1	0		171
5:00:00 PM	8	72	5	0	85	0	0		4	11	1	0	16	0	0		2	79	6	0	87	0	0		6	12	5	0	23	3	1		211
Grand Total	28	259	25	0	312	0	0		18	39	11	0	63	2	2		12	279	19	0	310	0	0		22	41	18	0	81	4	2		771
% Approach	9.0%	83.0%	8.0%	0.0%	0.0%	0.0%	0.0%		29.5%	57.4%	16.2%	0.0%	0.0%	0.0%	0.0%		3.9%	90.0%	6.1%	0.0%	0.0%	0.0%	0.0%		27.2%	50.6%	22.2%	0.0%	0.0%	0.0%	0.0%		
% Total	3.6%	33.6%	3.2%	0.0%	40.5%	0.0%	0.0%		2.3%	5.1%	1.4%	0.0%	8.8%	0.0%	0.0%		1.6%	36.2%	2.5%	0.0%	40.2%	0.0%	0.0%		2.9%	5.3%	2.3%	0.0%	10.5%	0.0%	0.0%		
PHF	0.875	0.841	0.694	0.000	0.857	0.000	0.000		0.900	0.813	0.458	0.000	0.944	0.000	0.000		0.750	0.883	0.679	0.000	0.891	0.000	0.000		0.688	0.732	0.900	0.000	0.810	0.000	0.000		
Lights	27	251	24	0	302	0	0		18	38	11	0	67	0	0		9	273	19	0	301	0	0		18	40	17	0	75	0	0		
% Lights	96.4%	96.9%	96.0%	0.0%	96.8%	0.0%	0.0%		100.0%	97.4%	100.0%	0.0%	98.5%	0.0%	0.0%		75.0%	97.8%	100.0%	0.0%	97.1%	0.0%	0.0%		81.8%	97.6%	94.4%	0.0%	92.6%	0.0%	0.0%		
Trucks	0	0	0	0	0	0	0		0	0	0	0	0	0	0		0	0	0	0	0	0	0		0	0	0	0	0	0	0		
% Trucks	0.0%	0.0%	0.0%	0.0%	0.0%	0.0%	0.0%		0.0%	0.0%	0.0%	0.0%	0.0%	0.0%	0.0%		0.0%	0.0%	0.0%	0.0%	0.0%	0.0%	0.0%		0.0%	0.0%	0.0%	0.0%	0.0%	0.0%	0.0%		
Buses	1	8	1	0	10	0	0		0	1	0	0	1	0	0		3	6	0	0	9	0	0		4	1	1	0	6	0	0		
% Buses	3.6%	3.1%	4.0%	0.0%	0.0%	0.0%	0.0%		0.0%	2.6%	0.0%	0.0%	0.0%	0.0%	0.0%		25.0%	2.2%	0.0%	0.0%	0.0%	0.0%	0.0%		18.2%	2.4%	5.6%	0.0%	0.0%	0.0%	0.0%		
Pedestrians	0	0	0	0	0	0	0		0	0	0	0	2	2	2		0	0	0	0	0	0	0		0	0	0	0	0	4	2		
% Pedestrians	0.0%	0.0%	0.0%	0.0%	0.0%	0.0%	100.0%		0.0%	0.0%	0.0%	0.0%	0.0%	100.0%	100.0%		0.0%	0.0%	0.0%	0.0%	0.0%	0.0%	0.0%		0.0%	0.0%	0.0%	0.0%	0.0%	100.0%	100.0%		
Bicycles on Crosswalk	0	0	0	0	0	0	0		0	0	0	0	0	0	0		0	0	0	0	0	0	0		0	0	0	0	0	0	0		
% Bicycles on Crosswalk	0.0%	0.0%	0.0%	0.0%	0.0%	0.0%	0.0%		0.0%	0.0%	0.0%	0.0%	0.0%	0.0%	0.0%		0.0%	0.0%	0.0%	0.0%	0.0%	0.0%	0.0%		0.0%	0.0%	0.0%	0.0%	0.0%	0.0%	0.0%		

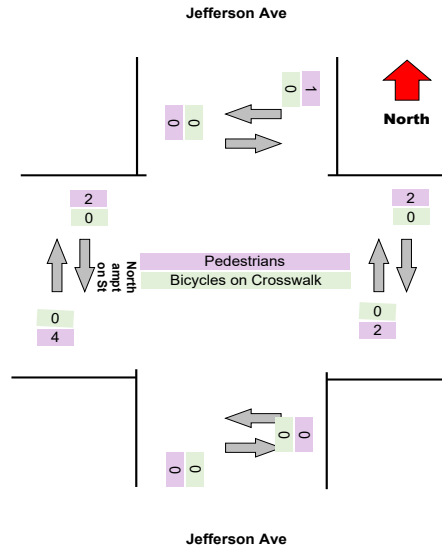
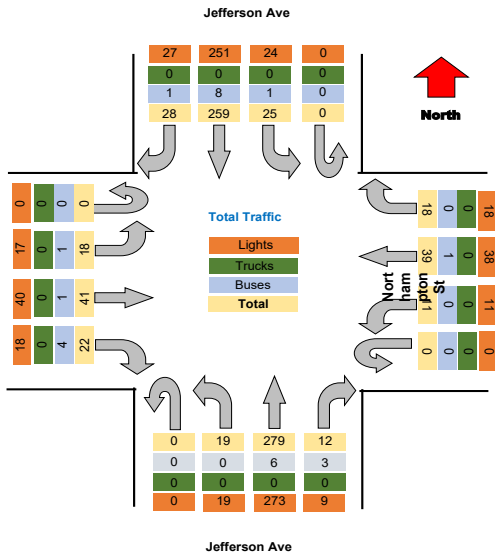

Turning Movement Data Plot

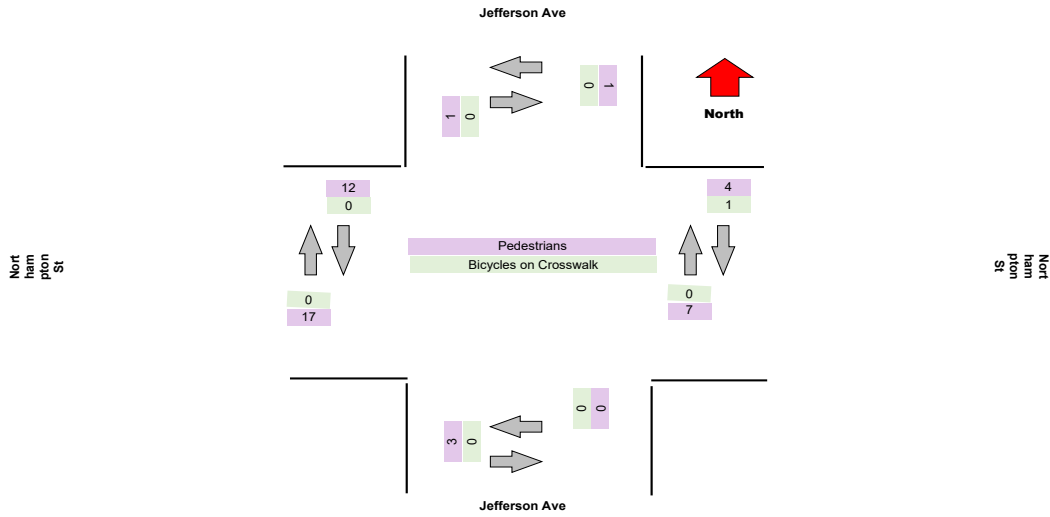
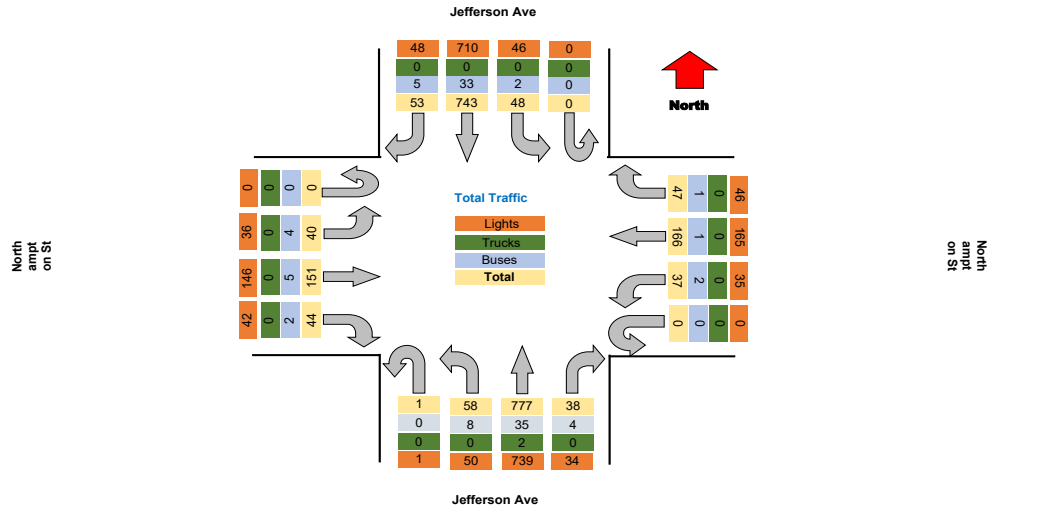

Project : VBH Malta NY
Site : Site 4
Location : 42.948550, -73.790036
Survey Date : 2021-04-28, Wednesday

TSTData.com

Turning Movement Peak Hour Data (AM)

7:30:00 AM

Leg Direction	Jefferson Ave					Northampton St					Jefferson Ave					Northampton St					Total									
	Southbound					Westbound					Northbound					Eastbound														
Start Time	Right	Thru	Left	U-Turn	App Total	Peds CW	Peds CCW	Right	Thru	Left	U-Turn	App Total	Peds CW	Peds CCW	Right	Thru	Left	U-Turn	App Total	Peds CW	Peds CCW	Right	Thru	Left	U-Turn	App Total	Peds CW	Peds CCW		
7:30:00 AM	2	36	2	0	40	0	1	0	9	2	0	12	0	0	1	32	3	0	0	36	0	0	2	6	1	0	9	0	0	97
7:45:00 AM	6	43	2	0	51	0	0	1	15	0	0	16	1	0	2	49	7	0	0	59	0	0	0	13	2	0	15	2	0	141
8:00:00 AM	3	44	2	0	49	0	0	1	17	5	0	23	0	0	2	41	4	0	0	47	0	2	3	10	1	0	14	0	0	133
8:15:00 AM	3	37	2	0	42	0	0	3	19	3	0	25	1	1	2	43	9	0	0	56	0	0	7	11	3	0	21	1	2	144
Grand Total	14	160	8	0	182	0	1	5	50	10	0	75	2	1	7	155	23	0	0	198	0	2	12	40	7	0	59	3	2	515
% Approach	7.7%	87.9%	4.4%	0.0%	0.0%	0.0%	0.0%	6.6%	78.9%	13.2%	0.0%	0.6%	0.0%	0.0%	3.5%	83.3%	11.6%	0.0%	0.0%	0.0%	0.0%	0.0%	20.3%	67.8%	11.9%	0.0%	0.0%	0.0%	0.0%	0.0%
% Total	2.7%	31.1%	1.6%	0.0%	35.3%	0.0%	0.0%	1.0%	11.7%	1.9%	0.0%	14.8%	0.0%	0.0%	1.4%	32.0%	4.5%	0.0%	38.4%	0.0%	0.0%	2.3%	7.8%	1.4%	0.0%	11.5%	0.0%	0.0%	0.0%	0.0%
PHF	0.583	0.909	1.000	0.000	0.892	0.000	0.000	0.417	0.789	0.500	0.000	0.760	0.000	0.000	0.875	0.842	0.639	0.000	0.839	0.000	0.000	0.429	0.769	0.583	0.000	0.702	0.000	0.000	0.894	
Lights	12	151	7	0	170	0	0	5	59	9	0	73	0	0	6	150	20	0	0	176	0	0	12	38	5	0	55	0	0	474
% Lights	85.7%	94.4%	87.5%	0.0%	93.4%	0.0%	0.0%	100.0%	98.3%	90.0%	0.0%	96.1%	0.0%	0.0%	85.7%	90.0%	87.0%	0.0%	88.9%	0.0%	0.0%	100.0%	95.0%	71.4%	0.0%	93.2%	0.0%	0.0%	92.0%	
Trucks	0	0	0	0	0	0	0	0	0	0	0	0	0	0	0	1	0	0	0	1	0	0	0	0	0	0	0	0	0	1
% Trucks	0.0%	0.0%	0.0%	0.0%	0.0%	0.0%	0.0%	0.0%	0.0%	0.0%	0.0%	0.0%	0.0%	0.0%	0.0%	0.6%	0.0%	0.0%	0.5%	0.0%	0.0%	0.0%	0.0%	0.0%	0.0%	0.0%	0.0%	0.0%	0.2%	
Buses	2	9	1	0	12	0	0	0	1	1	0	2	0	0	1	14	3	0	0	18	0	0	0	2	2	0	4	0	0	36
% Buses	14.3%	5.6%	12.5%	0.0%	6.6%	0.0%	0.0%	0.0%	1.7%	10.0%	0.0%	2.7%	0.0%	0.0%	14.3%	8.5%	13.0%	0.0%	9.1%	0.0%	0.0%	0.0%	5.0%	28.6%	0.0%	6.7%	0.0%	0.0%	7.0%	
Pedestrians	0	0	0	0	0	0	1	0	0	0	0	0	2	1	0	0	0	0	0	0	2	0	0	0	0	0	0	3	2	0
% Pedestrians	0.0%	0.0%	0.0%	0.0%	0.0%	100.0%	100.0%	0.0%	0.0%	0.0%	0.0%	0.0%	100.0%	100.0%	0.0%	0.0%	0.0%	0.0%	0.0%	0.0%	10.0%	0.0%	0.0%	0.0%	0.0%	0.0%	0.0%	0.0%	100.0%	0.0%
Bicycles on Crosswalk	0	0	0	0	0	0	0	0	0	0	0	0	0	0	0	0	0	0	0	0	0	0	0	0	0	0	0	0	0	0
% Bicycles on Crosswalk	0.0%	0.0%	0.0%	0.0%	0.0%	0.0%	0.0%	0.0%	0.0%	0.0%	0.0%	0.0%	0.0%	0.0%	0.0%	0.0%	0.0%	0.0%	0.0%	0.0%	0.0%	0.0%	0.0%	0.0%	0.0%	0.0%	0.0%	0.0%	0.0%	0.0%

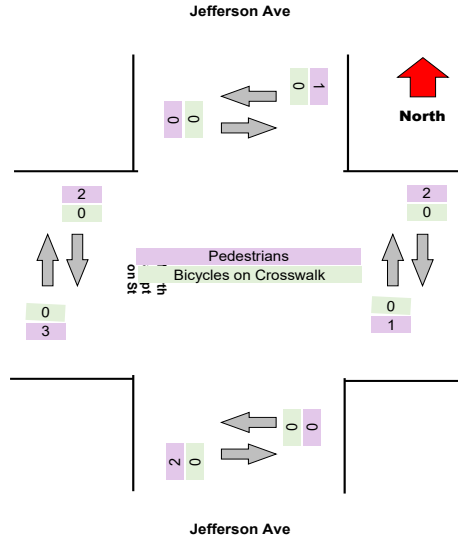
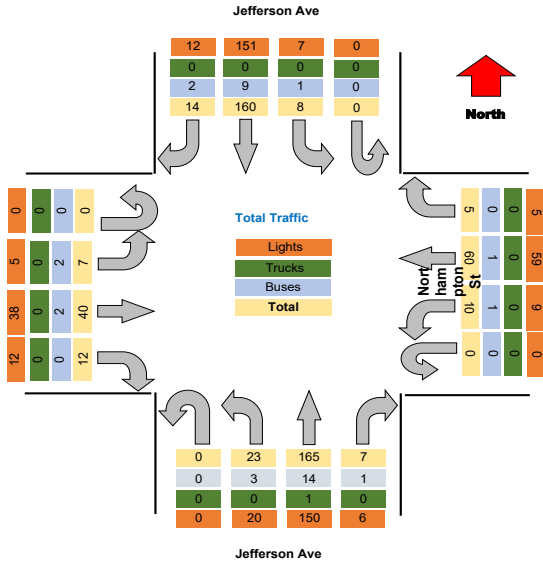

Turning Movement Peak Hour Data (PM)

4:15:00 PM

Leg Direction	Jefferson Ave				Northampton St				Jefferson Ave				Northampton St				Total													
	Southbound				Westbound				Northbound				Eastbound																	
	Right	Thru	Left	U-Turn	App Total	Peds CW	Peds CCW	Right	Thru	Left	U-Turn	App Total	Peds CW	Peds CCW	Right	Thru		Left	U-Turn	App Total	Peds CW	Peds CCW								
4:15:00 PM	9	70	5	0	84	0	0	2	17	0	0	19	0	0	6	73	2	0	81	0	0	2	13	7	0	22	3	0	206	
4:30:00 PM	4	65	0	0	69	1	0	4	13	4	0	21	1	1	0	66	3	0	69	0	0	5	19	4	0	28	0	0	187	
4:45:00 PM	6	52	4	0	62	0	0	7	12	1	0	20	0	1	3	73	3	0	79	0	0	5	15	6	0	26	1	2	187	
5:00:00 PM	6	71	4	0	81	0	0	4	10	2	0	16	0	0	5	64	4	1	74	0	0	4	8	6	0	18	0	1	189	
Grand Total	25	238	13	0	296	1	0	17	52	7	0	76	1	0	14	276	12	1	393	0	0	15	55	23	0	94	3	3	789	
% Approach	8.4%	87.2%	4.4%	0.0%	0.0%	0.0%	0.0%	22.4%	68.4%	9.2%	0.0%	0.0%	0.0%	0.0%	4.6%	91.1%	4.0%	0.3%	0.0%	0.0%	0.0%	17.0%	56.5%	24.5%	0.0%	0.0%	0.0%	0.0%	0.0%	
% Total	3.3%	33.6%	1.7%	0.0%	38.5%	0.0%	0.0%	2.2%	6.8%	0.9%	0.0%	9.9%	0.0%	0.0%	1.8%	35.9%	1.6%	0.1%	39.4%	0.0%	0.0%	2.1%	7.2%	3.0%	0.0%	12.2%	0.0%	0.0%	0.0%	
PHF	0.694	0.908	0.650	0.000	0.881	0.000	0.000	0.607	0.765	0.438	0.000	0.905	0.000	0.000	0.583	0.945	0.750	0.250	0.835	0.000	0.000	0.800	0.724	0.821	0.000	0.839	0.000	0.000	0.933	
Lights	25	248	12	0	285	0	0	17	52	7	0	76	0	0	13	266	11	1	291	0	0	14	53	22	0	89	0	0	741	
% Lights	100.0%	96.1%	92.3%	0.0%	96.3%	0.0%	0.0%	100.0%	100.0%	100.0%	0.0%	100.0%	0.0%	0.0%	82.9%	96.4%	91.7%	100.0%	96.0%	0.0%	0.0%	87.5%	96.4%	95.7%	0.0%	94.7%	0.0%	0.0%	96.4%	
Trucks	0	0	0	0	0	0	0	0	0	0	0	0	0	0	0	0	0	0	0	0	0	0	0	0	0	0	0	0	0	
% Trucks	0.0%	0.0%	0.0%	0.0%	0.0%	0.0%	0.0%	0.0%	0.0%	0.0%	0.0%	0.0%	0.0%	0.0%	0.0%	0.0%	0.0%	0.0%	0.0%	0.0%	0.0%	0.0%	0.0%	0.0%	0.0%	0.0%	0.0%	0.0%	0.0%	
Buses	0	10	1	0	11	0	0	0	0	0	0	0	0	0	1	9	1	0	11	0	0	2	2	1	0	5	0	0	27	
% Buses	0.0%	3.9%	7.7%	0.0%	0.0%	0.0%	0.0%	0.0%	0.0%	0.0%	0.0%	0.0%	0.0%	0.0%	7.1%	3.3%	8.3%	0.0%	0.0%	0.0%	0.0%	12.5%	3.6%	4.3%	0.0%	0.0%	0.0%	0.0%	3.5%	
Pedestrians	0	0	0	0	0	1	0	0	0	0	0	1	5	0	0	0	0	0	0	0	0	0	0	0	0	0	4	3	0	
% Pedestrians	0.0%	0.0%	0.0%	0.0%	0.0%	100.0%	0.0%	0.0%	0.0%	0.0%	0.0%	100.0%	100.0%	0.0%	0.0%	0.0%	0.0%	0.0%	0.0%	0.0%	0.0%	0.0%	0.0%	0.0%	0.0%	0.0%	0.0%	0.0%	100.0%	0.0%
Bicycles on Crosswalk	0	0	0	0	0	0	0	0	0	0	0	0	0	0	0	0	0	0	0	0	0	0	0	0	0	0	0	0	0	
% Bicycles on Crosswalk	0.0%	0.0%	0.0%	0.0%	0.0%	0.0%	0.0%	0.0%	0.0%	0.0%	0.0%	0.0%	0.0%	0.0%	0.0%	0.0%	0.0%	0.0%	0.0%	0.0%	0.0%	0.0%	0.0%	0.0%	0.0%	0.0%	0.0%	0.0%	0.0%	

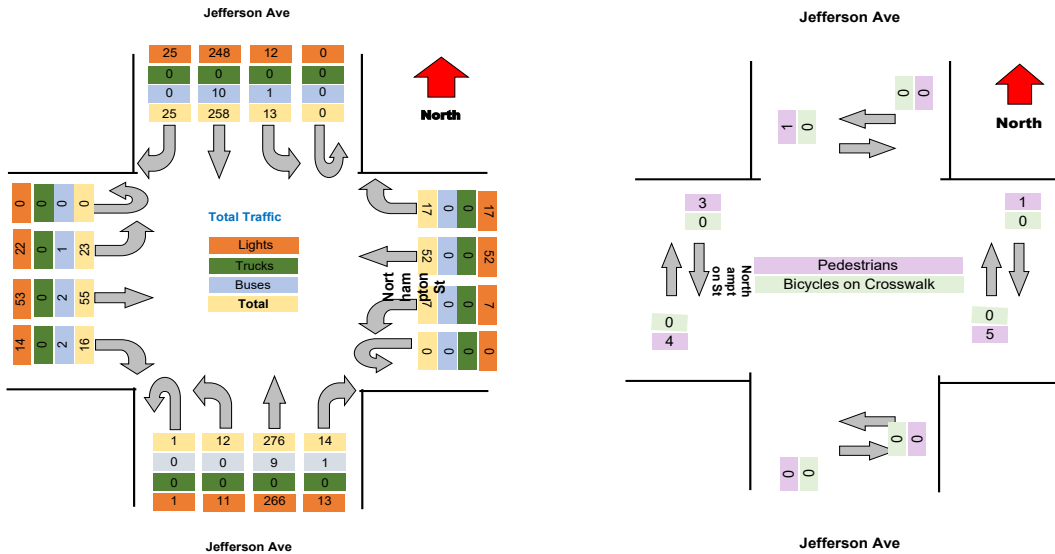

Project : VBH Malta NY
Site : Site 4
Location : 42.948550, -73.790036

TSTData.com

Survey Date : 2021-04-28, Wednesday

Project	LaBella
Project Code	LaBella
Site Name	36
Legs and Movements	All Processed Legs & Move
Bin Size	15 minutes
Survey Date	2021-11-02, Tuesday
Location	36
Latitude and Longitude	42.903857, -78.853998

	Start	End	PHF
Forced Peak AM	2021/11/02 07:30:00	2021/11/02 08:30:00	0.99
Forced Peak PM	2021/11/02 16:30:00	2021/11/02 17:30:00	0.92
AM Peak	2021/11/02 07:30:00	2021/11/02 08:30:00	0.99
PM Peak	2021/11/02 16:15:00	2021/11/02 17:15:00	0.9

Turning Movement Data

Leg Direction	Jefferson Ave								Best St				Jefferson Ave				Best St				Total											
	Southbound				Westbound				Northbound				Eastbound																			
Start Time	Right	Thru	Left	U-Turn	App Total	Peds CV	Peds CCV		Right	Thru	Left	U-Turn	App Total	Peds CV	Peds CCV		Right	Thru	Left	U-Turn	App Total	Peds CV	Peds CCV									
6:30:00 AM	1	9	3	0	13	0	0		7	56	9	0	72	0	0		7	11	0	0	18	1	0		1	22	0	0	23	0	0	126
6:45:00 AM	2	18	5	0	25	0	0		6	82	9	0	97	0	0		2	17	2	0	21	0	1		1	28	4	0	33	0	1	178
Hourly Total	3	27	8	0	38	0	0		13	138	18	0	169	0	0		9	28	2	0	39	1	1		2	50	4	0	56	0	1	302
7:00:00 AM	0	13	1	0	14	0	0		8	49	5	0	60	0	0		7	14	0	0	21	1	0		2	32	18	0	52	0	0	147
7:15:00 AM	1	20	7	0	28	0	0		8	49	7	0	64	0	1		3	17	1	0	22	0	0		1	32	2	0	35	1	0	149
7:30:00 AM	5	14	7	0	26	0	0		11	65	13	0	89	0	0		11	32	0	0	43	0	0		3	57	1	0	61	0	0	219
7:45:00 AM	2	28	7	0	37	0	0		5	92	5	0	102	0	1		4	19	5	0	29	0	0		4	49	1	0	54	0	0	222
Hourly Total	8	75	22	0	105	0	0		30	255	30	0	315	0	2		25	82	6	0	115	1	0		10	170	22	0	202	1	0	737
8:00:00 AM	3	29	4	0	36	0	0		17	66	5	0	88	1	0		5	30	8	0	44	0	0		7	46	1	0	54	0	0	222
8:15:00 AM	4	29	10	0	43	0	0		15	73	8	0	96	0	0		5	21	4	0	30	0	0		2	44	3	0	49	0	0	218
Hourly Total	7	58	14	0	79	0	0		32	139	13	0	184	1	0		10	51	12	0	74	0	0		9	90	4	0	103	0	0	440
4:00:00 PM	5	50	19	0	74	1	1		12	72	8	0	92	0	0		21	48	4	0	73	0	0		5	99	7	0	111	0	2	350
4:15:00 PM	6	46	17	0	69	0	0		10	75	4	0	89	0	1		19	38	6	0	63	0	1		12	84	5	0	101	0	0	322
4:30:00 PM	7	55	13	0	75	1	0		25	48	4	0	77	0	0		22	58	3	0	83	0	0		14	94	1	0	109	0	1	344
4:45:00 PM	10	45	9	0	64	0	0		16	55	7	0	78	0	2		13	60	1	0	74	0	1		2	86	6	0	94	0	0	310
Hourly Total	28	196	58	0	282	2	1		63	250	23	0	338	0	3		75	204	14	0	293	0	2		33	363	19	0	415	0	3	1326
5:00:00 PM	6	44	10	0	60	0	1		14	74	10	0	98	0	0		16	68	10	0	94	1	0		10	111	1	0	122	0	0	374
5:15:00 PM	5	59	22	0	86	0	0		15	75	6	0	96	5	0		20	41	9	0	70	0	0		6	90	3	0	99	0	0	351
5:30:00 PM	4	36	20	0	60	1	0		12	65	4	0	81	0	0		18	52	4	0	74	1	1		6	70	3	0	79	0	0	294
5:45:00 PM	7	45	8	0	60	1	0		18	63	4	0	85	0	2		8	46	4	0	58	1	0		6	76	2	0	84	2	0	287
Hourly Total	22	184	60	0	266	2	1		59	277	24	0	360	5	2		62	207	27	0	296	3	4		28	347	9	0	384	2	0	1306
Grand Total	68	540	162	0	770	4	2		197	1059	108	0	1364	6	7		181	572	61	0	817	5	7		82	1020	56	0	1160	5	4	4111
% Approach	8.8%	70.1%	21.0%	0.0%	0.0%	0.0%	0.0%		14.4%	77.6%	7.9%	0.0%	0.0%	0.0%	0.0%		22.2%	70.0%	7.5%	0.0%	0.0%	0.0%	0.0%		7.1%	87.9%	5.0%	0.0%	0.0%	0.0%	0.0%	0.0%
% Total	1.7%	13.1%	3.9%	0.0%	18.7%	0.0%	0.0%		4.8%	25.8%	2.6%	0.0%	33.2%	0.0%	0.0%		4.4%	13.9%	1.5%	0.0%	19.9%	0.0%	0.0%		2.0%	24.8%	1.4%	0.0%	28.2%	0.0%	0.0%	0.0%
Lights	66	529	160	0	755	0	0		196	1043	106	0	1345	0	0		181	556	60	0	797	0	0		82	1007	58	0	1147	0	0	4044
% Lights	97.1%	98.0%	98.9%	0.0%	98.1%	0.0%	0.0%		99.5%	98.9%	98.1%	0.0%	98.6%	0.0%	0.0%		100.0%	97.2%	98.4%	0.0%	97.6%	0.0%	0.0%		100.0%	98.7%	100.0%	0.0%	98.9%	0.0%	0.0%	98.4%
Trucks	0	1	0	0	1	0	0		1	1	0	0	2	0	0		0	0	0	0	0	0	0	0	0	0	0	0	0	0	0	3
% Trucks	0.0%	0.2%	0.0%	0.0%	0.1%	0.0%	0.0%		0.5%	0.1%	0.0%	0.0%	0.1%	0.0%	0.0%		0.0%	0.0%	0.0%	0.0%	0.0%	0.0%	0.0%	0.0%	0.0%	0.0%	0.0%	0.0%	0.0%	0.0%	0.0%	0.1%
Buses	2	9	2	0	13	0	0		0	14	2	0	16	0	0		0	15	1	0	16	0	0	0	0	12	0	0	12	0	0	57
% Buses	2.9%	1.7%	1.2%	0.0%	0.0%	0.0%	0.0%		0.0%	1.3%	1.9%	0.0%	0.0%	0.0%	0.0%		0.0%	2.6%	1.6%	0.0%	0.0%	0.0%	0.0%	0.0%	0.0%	1.2%	0.0%	0.0%	0.0%	0.0%	1.4%	
Pedestrians	0	0	0	0	0	4	2		0	0	0	0	0	6	7		0	0	0	0	0	5	7	0	0	0	0	1	3	0	0	0
% Pedestrians	0.0%	0.0%	0.0%	0.0%	0.0%	100.0%	100.0%		0.0%	0.0%	0.0%	0.0%	0.0%	100.0%	100.0%		0.0%	0.0%	0.0%	0.0%	0.0%	100.0%	100.0%		0.0%	0.0%	0.0%	0.0%	33.3%	75.0%	0.0%	
Bicycles on Crosswalk	0	0	0	0	0	0	0		0	0	0	0	0	0	0		0	0	0	0	0	0	0	0	0	0	0	0	2	1	0	
% Bicycles on Crosswalk	0.0%	0.0%	0.0%	0.0%	0.0%	0.0%	0.0%		0.0%	0.0%	0.0%	0.0%	0.0%	0.0%	0.0%		0.0%	0.0%	0.0%	0.0%	0.0%	0.0%	0.0%	0.0%	0.0%	0.0%	0.0%	0.0%	66.7%	25.0%	0.0%	

Turning Movement Data Plot

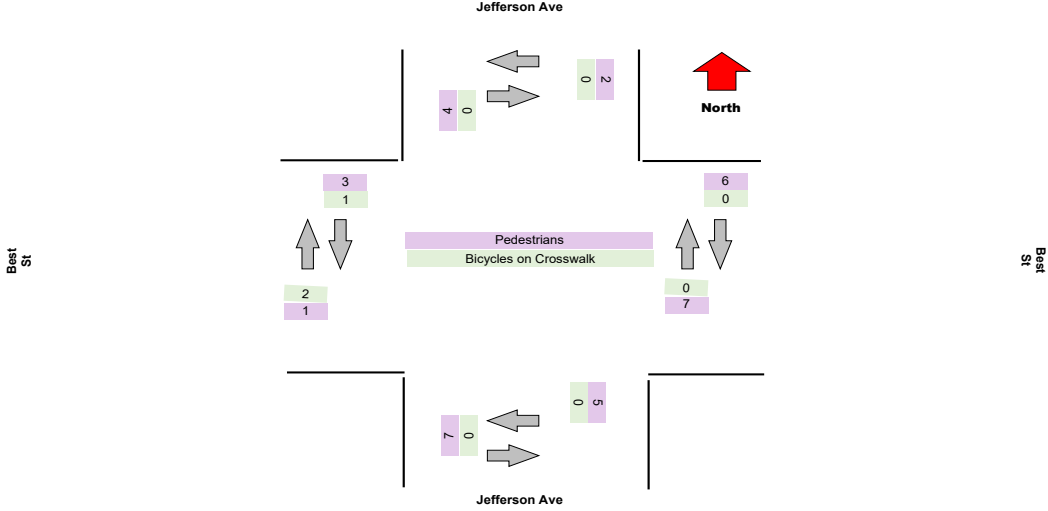
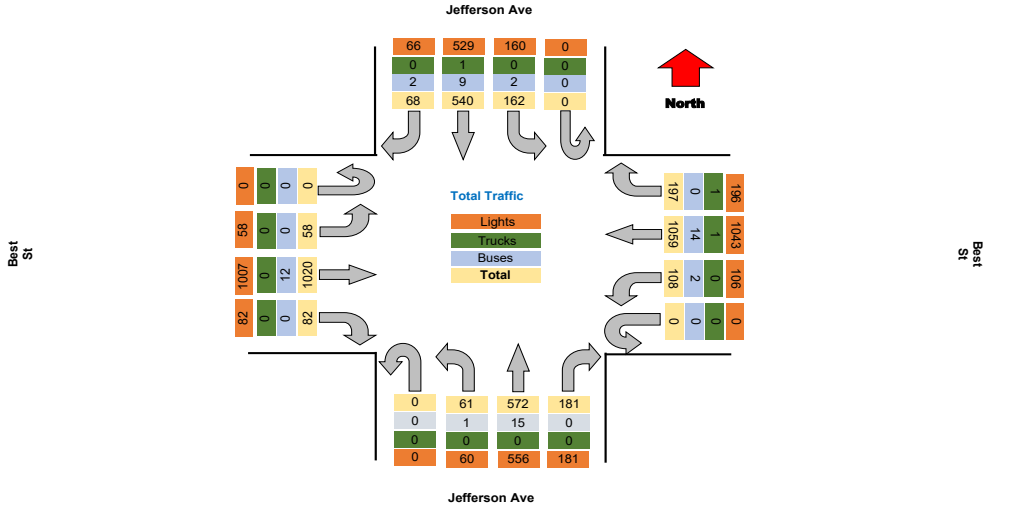

Project : VBH Malta NY
Site : Site 4
Location : 42.948550, -73.790036

TSTData.com

Survey Date : 2021-04-28, Wednesday

Turning Movement Peak Hour Data (AM)

7:30:00 AM

Leg Direction	Jefferson Ave				Best St				Jefferson Ave				Best St				Total				
	Southbound		Northbound		Westbound		Eastbound		Northbound		Eastbound		Westbound		Eastbound						
Start Time	Right	Thru	Left	U-Turn	App Total	Peds CW	Peds CCW	Right	Thru	Left	U-Turn	App Total	Peds CW	Peds CCW	Right	Thru	Left	U-Turn	App Total	Peds CW	Peds CCW
7:30:00 AM	5	14	7	0	26	0	0	11	65	13	0	89	0	0	11	32	0	0	43	0	0
7:45:00 AM	2	28	7	0	37	0	0	5	92	5	0	102	0	1	4	19	5	0	29	0	0
8:00:00 AM	3	29	4	0	36	0	0	17	66	5	0	88	1	0	5	30	8	0	44	0	0
8:15:00 AM	4	29	10	0	43	0	0	15	73	8	0	96	0	0	5	21	4	0	30	0	0
Grand Total	14	109	28	0	142	0	0	48	296	31	0	375	1	1	25	102	17	0	146	0	0
% Approach	9.9%	70.4%	19.7%	0.0%	0.0%	0.0%	0.0%	12.8%	78.9%	8.3%	0.0%	0.0%	0.0%	0.0%	17.1%	69.9%	11.6%	0.0%	0.0%	0.0%	0.0%
% Total	1.6%	11.4%	3.2%	0.0%	16.1%	0.0%	0.0%	5.4%	33.6%	3.5%	0.0%	42.6%	0.0%	0.0%	2.8%	11.6%	1.9%	0.0%	16.6%	0.0%	0.0%
PHF	0.700	0.862	0.700	0.000	0.826	0.000	0.000	0.706	0.804	0.596	0.000	0.919	0.000	0.000	0.568	0.797	0.531	0.000	0.830	0.000	0.000
Lights	13	98	27	0	138	0	0	48	292	29	0	369	0	0	25	99	17	0	141	0	0
% Lights	92.9%	98.0%	96.4%	0.0%	97.2%	0.0%	0.0%	100.0%	98.6%	93.5%	0.0%	98.4%	0.0%	0.0%	100.0%	97.1%	100.0%	0.0%	96.6%	0.0%	0.0%
Trucks	0	0	0	0	0	0	0	0	0	0	0	0	0	0	0	0	0	0	0	0	0
% Trucks	0.0%	0.0%	0.0%	0.0%	0.0%	0.0%	0.0%	0.0%	0.0%	0.0%	0.0%	0.0%	0.0%	0.0%	0.0%	0.0%	0.0%	0.0%	0.0%	0.0%	0.0%
Buses	1	2	1	0	4	0	0	0	4	2	0	6	0	0	0	3	0	0	3	0	0
% Buses	7.1%	2.0%	3.6%	0.0%	0.0%	0.0%	0.0%	0.0%	1.4%	6.5%	0.0%	0.0%	0.0%	0.0%	0.0%	2.9%	0.0%	0.0%	0.0%	0.0%	0.0%
Pedestrians	0	0	0	0	0	0	0	0	0	0	0	1	1	0	0	0	0	0	0	0	0
% Pedestrians	0.0%	0.0%	0.0%	0.0%	0.0%	0.0%	0.0%	0.0%	0.0%	0.0%	0.0%	0.0%	100.0%	100.0%	0.0%	0.0%	0.0%	0.0%	0.0%	0.0%	0.0%
Bicycles on Crosswalk	0	0	0	0	0	0	0	0	0	0	0	0	0	0	0	0	0	0	0	0	0
% Bicycles on Crosswalk	0.0%	0.0%	0.0%	0.0%	0.0%	0.0%	0.0%	0.0%	0.0%	0.0%	0.0%	0.0%	0.0%	0.0%	0.0%	0.0%	0.0%	0.0%	0.0%	0.0%	0.0%

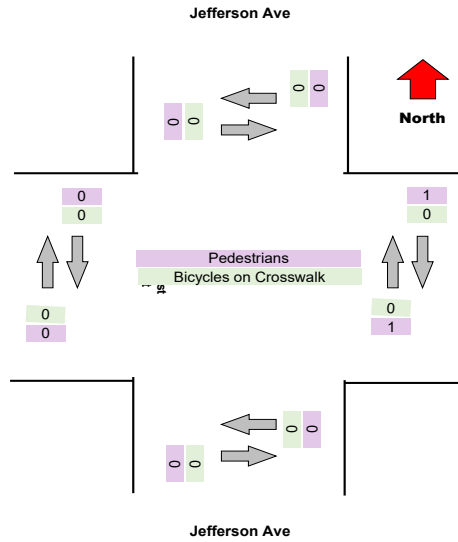
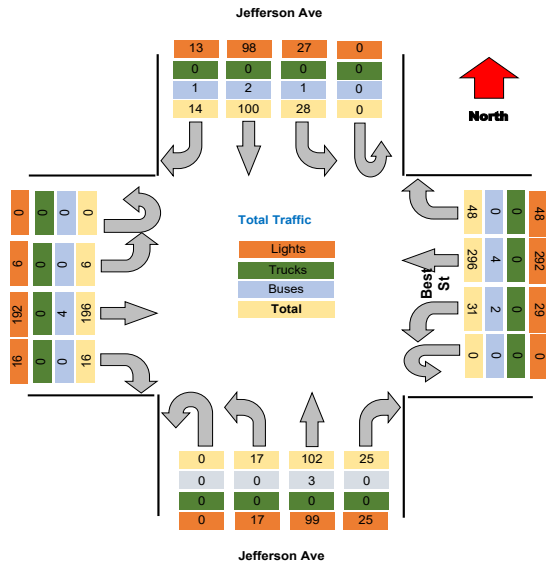

Turning Movement Peak Hour Data (PM)

4:15:00 PM

Leg Direction	Jefferson Ave										Best St				Jefferson Ave										Best St				Total
	Southbound					Westbound					Northbound					Eastbound													
	Right	Thru	Left	U-Turn	App Total	Right	Thru	Left	U-Turn	App Total	Right	Thru	Left	U-Turn	App Total	Right	Thru	Left	U-Turn	App Total									
4:15:00 PM	6	46	17	0	69	10	75	4	0	89	19	38	6	0	63	12	84	5	0	101									
4:30:00 PM	7	55	13	0	75	25	48	4	0	77	22	58	3	0	83	14	94	1	0	109									
4:45:00 PM	10	45	9	0	64	16	55	7	0	78	13	60	1	0	74	2	86	6	0	94									
5:00:00 PM	6	44	10	0	60	14	74	10	0	98	16	56	10	0	82	10	111	1	0	122									
Grand Total	29	190	49	0	268	65	252	25	0	342	70	224	20	0	314	38	375	13	0	426									
% Approach	10.8%	70.9%	18.3%	0.0%	0.0%	19.0%	73.7%	7.3%	0.0%	0.0%	22.3%	71.3%	6.4%	0.0%	0.0%	8.9%	86.0%	3.1%	0.0%	0.0%									
% Total	2.1%	14.1%	3.6%	0.0%	19.9%	4.8%	18.7%	1.9%	0.0%	25.3%	5.2%	16.6%	1.5%	0.0%	23.3%	2.8%	27.8%	1.0%	0.0%	31.6%									
PHF	0.725	0.864	0.721	0.000	0.893	0.650	0.840	0.625	0.000	0.872	0.795	0.824	0.500	0.000	0.835	0.679	0.845	0.542	0.000	0.873									
Lights	28	185	49	0	262	65	248	25	0	338	70	218	19	0	307	38	371	13	0	422									
% Lights	96.6%	97.4%	100.0%	0.0%	97.8%	100.0%	98.4%	100.0%	0.0%	98.8%	100.0%	97.3%	95.0%	0.0%	97.8%	100.0%	98.9%	100.0%	0.0%	99.1%									
Trucks	0	1	0	0	1	0	0	0	0	0	0	0	0	0	0	0	0	0	0	0									
% Trucks	0.0%	0.5%	0.0%	0.0%	0.4%	0.0%	0.0%	0.0%	0.0%	0.0%	0.0%	0.0%	0.0%	0.0%	0.0%	0.0%	0.0%	0.0%	0.0%	0.0%									
Buses	1	3	0	0	4	0	3	0	0	3	0	5	1	0	6	0	3	0	0	3									
% Buses	3.4%	1.6%	0.0%	0.0%	0.0%	0.0%	1.2%	0.0%	0.0%	0.0%	0.0%	2.2%	5.0%	0.0%	0.0%	0.0%	0.8%	0.0%	0.0%	0.0%									
Pedestrians	0	0	0	0	0	0	0	0	0	0	0	0	0	0	0	0	0	0	0	0									
% Pedestrians	0.0%	0.0%	0.0%	0.0%	0.0%	0.0%	0.0%	0.0%	0.0%	0.0%	0.0%	0.0%	0.0%	0.0%	0.0%	0.0%	0.0%	0.0%	0.0%	0.0%									
Bicycles on Crosswalk	0	0	0	0	0	0	0	0	0	0	0	0	0	0	0	0	0	0	0	0									
% Bicycles on Crosswalk	0.0%	0.0%	0.0%	0.0%	0.0%	0.0%	0.0%	0.0%	0.0%	0.0%	0.0%	0.0%	0.0%	0.0%	0.0%	0.0%	0.0%	0.0%	0.0%	0.0%									

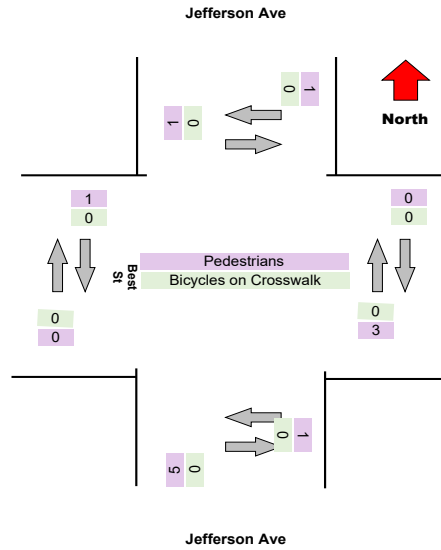
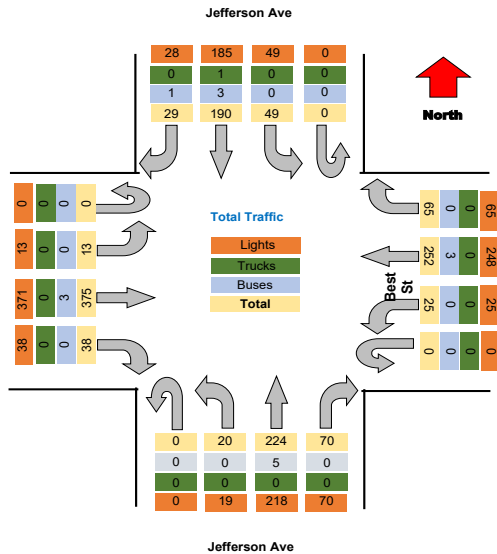

Turning Movement Data Plot

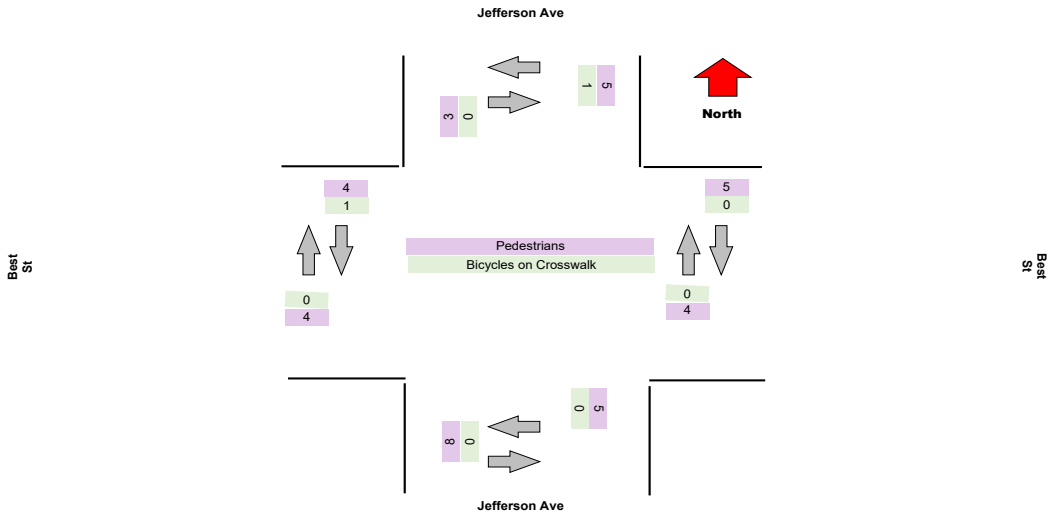
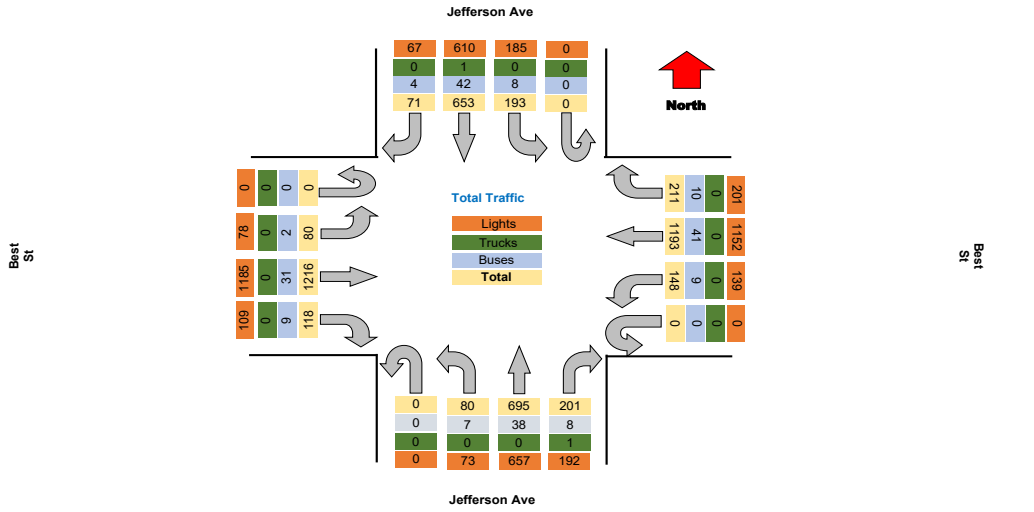

Project : VBH Malta NY
Site : Site 4
Location : 42.948550, -73.790036
Survey Date : 2021-04-28, Wednesday

TSTData.com

Turning Movement Peak Hour Data (AM)

7:30:00 AM

Leg Direction	Jefferson Ave										Best St										Jefferson Ave										Best St										Total
	Southbound					Westbound					Northbound					Eastbound																									
Start Time	Right	Thru	Left	U-Turn	App Total	Peds CW	Peds CCW	Right	Thru	Left	U-Turn	App Total	Peds CW	Peds CCW	Right	Thru	Left	U-Turn	App Total	Peds CW	Peds CCW	Right	Thru	Left	U-Turn	App Total	Peds CW	Peds CCW													
7:30:00 AM	5	30	12	0	47	0	0	7	81	7	0	95	0	1	9	32	2	0	44	1	0	7	81	4	0	92	0	0	278												
7:45:00 AM	10	49	9	0	68	0	0	10	106	19	0	135	0	0	12	36	8	0	56	0	0	9	96	3	0	108	0	0	367												
8:00:00 AM	5	51	12	0	68	0	0	15	105	10	0	130	0	1	15	35	4	0	55	1	0	16	92	7	0	115	0	0	368												
8:15:00 AM	2	35	6	0	43	0	0	19	74	5	0	100	0	0	6	37	5	0	48	1	0	5	60	5	0	70	0	1	261												
Grand Total	22	165	39	0	226	0	0	51	366	41	0	459	0	2	42	140	19	0	253	3	0	37	329	19	0	385	0	1	1274												
% Approach	9.7%	73.0%	17.3%	0.0%	0.0%	0.0%	0.0%	11.1%	79.6%	8.9%	0.0%	0.0%	0.0%	20.7%	69.0%	9.4%	0.0%	0.0%	0.0%	0.0%	0.0%	9.6%	85.5%	4.9%	0.0%	0.0%	0.0%	0.0%													
% Total	1.7%	13.0%	3.1%	0.0%	17.7%	0.0%	0.0%	4.0%	28.7%	3.2%	0.0%	36.1%	0.0%	0.0%	3.3%	11.0%	1.5%	0.0%	15.9%	0.0%	0.0%	2.9%	25.8%	1.5%	0.0%	30.2%	0.0%	0.0%													
PHF	0.550	0.809	0.613	0.000	0.831	0.000	0.000	0.671	0.863	0.539	0.000	0.852	0.000	0.000	0.700	0.946	0.594	0.000	0.806	0.000	0.000	0.578	0.857	0.679	0.000	0.837	0.000	0.000	0.865												
Lights	19	148	37	0	204	0	0	49	352	39	0	440	0	0	38	126	15	0	179	0	0	31	324	19	0	374	0	0	1197												
% Lights	86.4%	89.7%	94.9%	0.0%	90.3%	0.0%	0.0%	96.1%	96.2%	95.1%	0.0%	95.7%	0.0%	0.0%	90.5%	90.0%	78.9%	0.0%	88.2%	0.0%	0.0%	83.8%	98.5%	100.0%	0.0%	97.1%	0.0%	0.0%	94.0%												
Trucks	0	0	0	0	0	0	0	0	0	0	0	0	0	0	0	0	0	0	0	0	0	0	0	0	0	0	0	0	0												
% Trucks	0.0%	0.0%	0.0%	0.0%	0.0%	0.0%	0.0%	0.0%	0.0%	0.0%	0.0%	0.0%	0.0%	0.0%	0.0%	0.0%	0.0%	0.0%	0.0%	0.0%	0.0%	0.0%	0.0%	0.0%	0.0%	0.0%	0.0%	0.0%	0.0%												
Buses	3	17	2	0	22	0	0	2	14	2	0	18	0	0	4	14	4	0	22	0	0	6	5	0	0	11	0	0	73												
% Buses	13.6%	10.3%	5.1%	0.0%	0.0%	0.0%	0.0%	3.9%	3.8%	4.9%	0.0%	0.0%	0.0%	9.5%	10.0%	21.1%	0.0%	0.0%	0.0%	0.0%	16.2%	1.5%	0.0%	0.0%	0.0%	0.0%	0.0%	5.7%													
Pedestrians	0	0	0	0	0	0	2	0	0	0	0	0	2	0	0	0	0	3	0	0	0	0	0	0	0	0	1	0													
% Pedestrians	0.0%	0.0%	0.0%	0.0%	0.0%	0.0%	100.0%	0.0%	0.0%	0.0%	0.0%	0.0%	100.0%	0.0%	0.0%	0.0%	0.0%	0.0%	100.0%	0.0%	0.0%	0.0%	0.0%	0.0%	0.0%	0.0%	100.0%	0.0%													
Bicycles on Crosswalk	0	0	0	0	0	0	0	0	0	0	0	0	0	0	0	0	0	0	0	0	0	0	0	0	0	0	0	0	0												
% Bicycles on Crosswalk	0.0%	0.0%	0.0%	0.0%	0.0%	0.0%	0.0%	0.0%	0.0%	0.0%	0.0%	0.0%	0.0%	0.0%	0.0%	0.0%	0.0%	0.0%	0.0%	0.0%	0.0%	0.0%	0.0%	0.0%	0.0%	0.0%	0.0%	0.0%	0.0%												

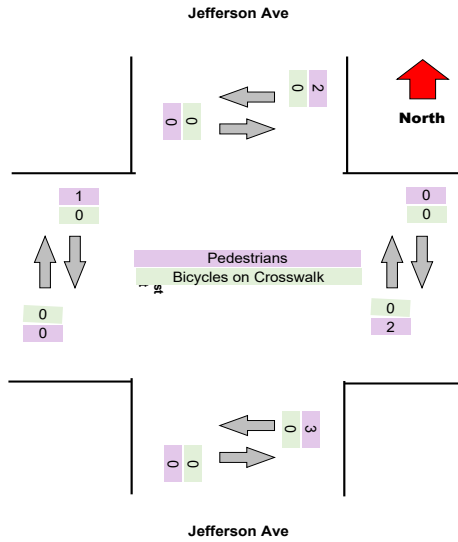
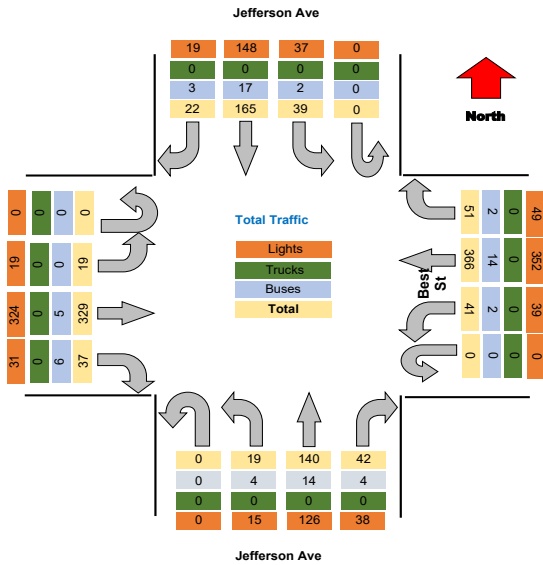

Turning Movement Peak Hour Data (PM)

4:15:00 PM

Leg Direction	Jefferson Ave					Best St					Jefferson Ave					Best St					Total								
	Southbound					Westbound					Northbound					Eastbound													
Start Time	Right	Thru	Left	U-Turn	App Total	Peds CW	Peds CCW	Right	Thru	Left	U-Turn	App Total	Peds CW	Peds CCW	Right	Thru	Left	U-Turn	App Total	Peds CW	Peds CCW	App Total	Peds CW	Peds CCW					
4:15:00 PM	4	52	22	0	78	0	0	19	82	10	0	111	1	0	17	59	6	0	82	0	0	9	100	3	0	112	0	0	383
4:30:00 PM	9	63	20	0	92	0	0	7	65	10	0	82	0	0	22	48	5	0	75	0	1	8	109	2	0	119	0	0	368
4:45:00 PM	3	44	10	0	57	0	0	13	65	4	0	82	0	0	18	61	3	0	82	0	1	12	86	5	0	103	0	0	324
5:00:00 PM	6	63	14	0	83	0	0	19	74	11	0	104	1	0	17	73	10	0	100	2	2	10	105	3	0	118	0	0	405
Grand Total	22	222	66	0	310	0	0	58	286	35	0	379	2	0	74	281	24	0	379	2	4	39	400	13	0	452	0	0	1489
% Approach	7.1%	71.6%	21.3%	0.0%	0.0%	0.0%	0.0%	15.3%	75.5%	9.2%	0.0%	0.0%	0.0%	0.0%	21.8%	71.1%	7.1%	0.0%	0.0%	0.0%	0.0%	8.6%	85.5%	2.9%	0.0%	0.0%	0.0%	0.0%	0.0%
% Total	1.5%	15.0%	4.5%	0.0%	20.8%	0.0%	0.0%	3.9%	19.3%	2.4%	0.0%	25.6%	0.0%	0.0%	5.0%	16.3%	1.6%	0.0%	22.9%	0.0%	0.0%	2.6%	27.0%	0.9%	0.0%	30.5%	0.0%	0.0%	0.0%
PHF	0.611	0.881	0.750	0.000	0.842	0.000	0.000	0.763	0.872	0.795	0.000	0.854	0.000	0.000	0.841	0.825	0.600	0.000	0.848	0.000	0.000	0.813	0.917	0.650	0.000	0.950	0.000	0.000	0.914
Lights	22	213	64	0	299	0	0	55	279	31	0	365	0	0	73	233	22	0	328	0	0	38	389	12	0	439	0	0	1431
% Lights	100.0%	95.9%	97.0%	0.0%	96.5%	0.0%	0.0%	94.8%	97.6%	88.6%	0.0%	96.3%	0.0%	0.0%	88.6%	96.7%	91.7%	0.0%	96.8%	0.0%	0.0%	97.4%	97.3%	92.3%	0.0%	97.1%	0.0%	0.0%	96.7%
Trucks	0	0	0	0	0	0	0	0	0	0	0	0	0	0	0	0	0	0	0	0	0	0	0	0	0	0	0	0	0
% Trucks	0.0%	0.0%	0.0%	0.0%	0.0%	0.0%	0.0%	0.0%	0.0%	0.0%	0.0%	0.0%	0.0%	0.0%	0.0%	0.0%	0.0%	0.0%	0.0%	0.0%	0.0%	0.0%	0.0%	0.0%	0.0%	0.0%	0.0%	0.0%	0.0%
Buses	0	9	2	0	11	0	0	3	7	4	0	14	0	0	1	8	2	0	11	0	0	1	11	1	0	13	0	0	49
% Buses	0.0%	4.1%	3.0%	0.0%	0.0%	0.0%	0.0%	5.2%	2.4%	11.4%	0.0%	0.0%	0.0%	0.0%	1.4%	3.3%	8.3%	0.0%	0.0%	0.0%	0.0%	2.6%	2.8%	7.7%	0.0%	0.0%	0.0%	3.3%	
Pedestrians	0	0	0	0	0	0	0	0	0	0	0	0	2	0	0	0	0	0	0	2	4	0	0	0	0	0	0	0	0
% Pedestrians	0.0%	0.0%	0.0%	0.0%	0.0%	0.0%	100.0%	0.0%	0.0%	0.0%	0.0%	0.0%	100.0%	0.0%	0.0%	0.0%	0.0%	0.0%	0.0%	0.0%	100.0%	0.0%	0.0%	0.0%	0.0%	0.0%	0.0%	0.0%	0.0%
Bicycles on Crosswalk	0	0	0	0	0	0	0	0	0	0	0	0	0	0	0	0	0	0	0	0	0	0	0	0	0	0	0	0	0
% Bicycles on Crosswalk	0.0%	0.0%	0.0%	0.0%	0.0%	0.0%	0.0%	0.0%	0.0%	0.0%	0.0%	0.0%	0.0%	0.0%	0.0%	0.0%	0.0%	0.0%	0.0%	0.0%	0.0%	0.0%	0.0%	0.0%	0.0%	0.0%	0.0%	0.0%	0.0%

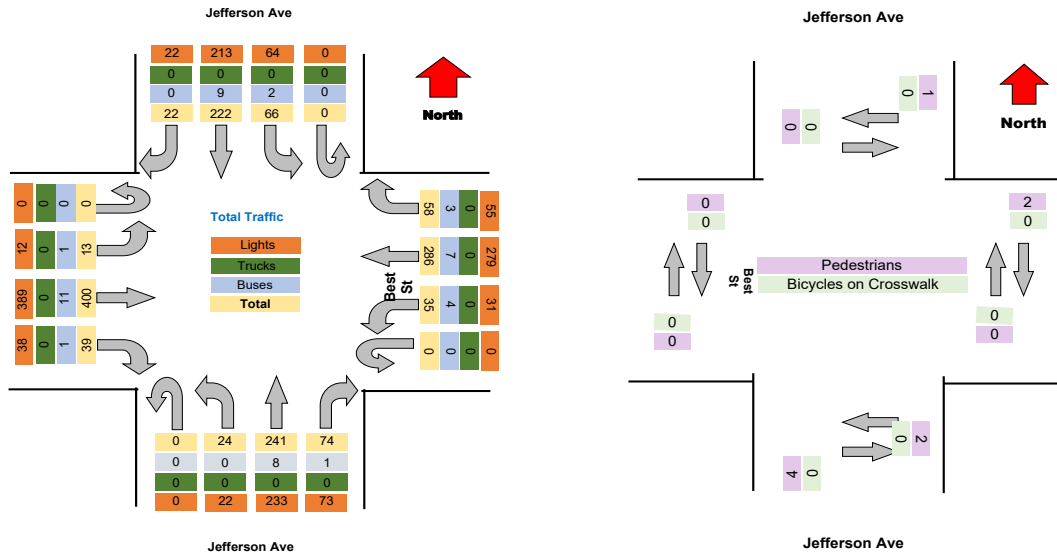

Project : VBH Malta NY
Site : Site 4
Location : 42.948550, -73.790036

TSTData.com

Survey Date : 2021-04-28, Wednesday

Project	LaBella
Project Code	LaBella
Site Name	36
Legs and Movements	All Processed Legs & Move
Bin Size	15 minutes
Survey Date	2021-11-04, Thursday
Location	36
Latitude and Longitude	42.903857, -78.853998

	Start	End	PHF
Forced Peak AM	2021/11/04 07:30:00	2021/11/04 08:30:00	0.84
Forced Peak PM	2021/11/04 16:30:00	2021/11/04 17:30:00	0.87
AM Peak	2021/11/04 07:30:00	2021/11/04 08:30:00	0.84
PM Peak	2021/11/04 16:15:00	2021/11/04 17:15:00	0.98

Turning Movement Data

Leg Direction	Jefferson Ave							Best St							Jefferson Ave							Best St							Total
	Southbound							Westbound							Northbound							Eastbound							
	Right	Thru	Left	U-Turn	App Total	Peds CV	Peds CCV	Right	Thru	Left	U-Turn	App Total	Peds CV	Peds CCV	Right	Thru	Left	U-Turn	App Total	Peds CV	Peds CCV	Right	Thru	Left	U-Turn	App Total	Peds CV	Peds CCV	
6:30:00 AM	2	14	5	0	21	0	0	4	76	13	0	93	0	0	2	14	2	0	18	0	0	1	31	0	0	32	0	0	164
6:45:00 AM	0	11	2	0	13	0	0	8	78	11	0	97	2	0	5	23	0	0	30	1	0	2	34	0	0	36	1	0	178
Hourly Total	2	25	7	0	34	0	0	12	154	24	0	190	2	0	7	37	2	0	48	1	0	3	65	0	0	68	1	0	340
7:00:00 AM	2	19	3	0	24	1	0	7	57	4	0	68	0	1	4	21	2	0	28	0	0	0	31	3	0	34	2	0	154
7:15:00 AM	1	29	10	0	40	1	0	12	63	11	0	86	0	0	6	22	2	0	30	0	0	6	45	2	0	53	1	0	209
7:30:00 AM	4	35	11	0	50	0	0	8	69	9	0	86	0	0	11	35	3	0	49	1	0	7	70	3	0	80	0	1	265
7:45:00 AM	8	29	8	0	45	0	1	20	113	17	0	151	0	0	9	42	7	0	58	0	0	9	117	5	0	131	0	0	385
Hourly Total	15	112	32	0	159	2	1	47	302	41	0	391	0	1	30	120	14	0	165	1	0	22	263	13	0	298	3	1	1013
8:00:00 AM	5	39	7	0	51	0	0	11	95	14	0	120	0	0	12	45	6	0	63	0	0	16	101	1	0	118	0	0	352
8:15:00 AM	6	35	7	0	48	0	1	17	85	9	0	112	0	0	8	38	2	0	48	1	0	8	68	5	0	81	0	0	289
Hourly Total	11	74	14	0	99	0	1	28	180	23	0	232	0	0	20	83	8	0	111	1	0	24	169	6	0	199	0	0	641
4:00:00 PM	8	59	15	0	82	0	0	19	75	5	0	99	0	0	19	49	2	0	70	1	0	15	118	2	0	135	1	1	386
4:15:00 PM	5	61	12	0	78	0	0	12	71	1	0	84	0	2	11	51	6	0	68	0	0	12	97	10	0	119	0	0	349
4:30:00 PM	6	50	20	0	76	0	0	16	49	6	0	71	0	1	19	58	7	0	84	1	0	9	104	6	0	119	1	0	350
4:45:00 PM	5	40	18	0	63	0	0	17	56	9	0	82	0	0	10	61	8	0	79	0	1	10	66	3	0	109	0	1	333
Hourly Total	24	210	65	0	299	0	0	64	251	21	0	336	0	3	59	219	23	0	301	2	1	46	415	21	0	482	2	2	1418
5:00:00 PM	10	67	15	0	82	0	0	10	65	3	0	78	0	0	11	61	5	0	77	0	0	7	103	5	0	115	0	0	352
5:15:00 PM	8	53	17	0	78	1	0	19	60	7	0	86	0	0	8	46	12	0	66	1	0	4	93	3	0	100	1	0	330
5:30:00 PM	7	43	18	0	68	2	0	12	82	6	0	100	1	0	20	56	5	0	81	0	0	12	67	4	0	83	0	0	332
5:45:00 PM	6	42	24	0	72	0	0	12	72	7	0	91	2	0	18	55	5	0	78	0	1	5	71	3	0	79	1	1	320
Hourly Total	31	195	74	0	300	3	2	53	279	23	0	355	3	0	57	218	27	0	302	1	1	28	334	15	0	377	2	1	1334
Grand Total	83	616	192	0	891	5	4	204	1166	132	0	1504	5	4	173	677	74	0	927	6	2	123	1246	55	0	1424	6	4	4746
% Approach	9.3%	69.1%	21.5%	0.0%	0.0%	0.0%	0.0%	13.6%	77.5%	8.8%	0.0%	0.0%	0.0%	0.0%	18.7%	73.0%	8.0%	0.0%	0.0%	0.0%	0.0%	8.6%	87.5%	3.9%	0.0%	0.0%	0.0%	0.0%	0.0%
% Total	1.7%	13.0%	4.0%	0.0%	18.8%	0.0%	0.0%	4.3%	24.6%	2.8%	0.0%	31.7%	0.0%	0.0%	3.6%	14.3%	1.6%	0.0%	19.5%	0.0%	0.0%	2.6%	26.3%	1.2%	0.0%	30.0%	0.0%	0.0%	0.0%
Lights	77	576	188	0	841	0	0	194	1124	124	0	1442	0	0	169	636	69	0	874	0	0	113	1217	51	0	1381	0	0	4538
% Lights	92.8%	93.5%	97.9%	0.0%	84.4%	0.0%	0.0%	95.1%	96.4%	93.9%	0.0%	95.9%	0.0%	0.0%	97.7%	93.9%	93.2%	0.0%	94.3%	0.0%	0.0%	91.9%	97.7%	92.7%	0.0%	97.0%	0.0%	0.0%	95.6%
Trucks	1	0	0	0	1	0	0	0	1	0	0	1	0	0	0	0	0	0	0	0	0	0	0	1	0	1	0	0	3
% Trucks	1.2%	0.0%	0.0%	0.0%	0.1%	0.0%	0.0%	0.0%	0.1%	0.0%	0.0%	0.1%	0.0%	0.0%	0.0%	0.0%	0.0%	0.0%	0.0%	0.0%	0.0%	0.0%	0.0%	1.8%	0.0%	0.1%	0.0%	0.0%	0.1%
Buses	5	39	4	0	48	0	0	10	41	8	0	59	0	0	4	41	5	0	50	0	0	9	29	3	0	41	0	0	198
% Buses	6.0%	6.3%	2.1%	0.0%	0.0%	0.0%	0.0%	0.0%	3.5%	6.1%	0.0%	0.0%	0.0%	0.0%	2.3%	6.1%	6.8%	0.0%	0.0%	0.0%	0.0%	7.3%	2.3%	5.5%	0.0%	0.0%	0.0%	0.0%	4.2%
Pedestrians	0	0	0	0	0	5	4	0	0	0	0	0	4	2	0	0	0	0	0	5	2	0	0	0	0	0	8	4	0
% Pedestrians	0.0%	0.0%	0.0%	0.0%	0.0%	100.0%	100.0%	0.0%	0.0%	0.0%	0.0%	0.0%	80.0%	50.0%	0.0%	0.0%	0.0%	0.0%	0.0%	83.3%	100.0%	0.0%	0.0%	0.0%	0.0%	0.0%	100.0%	100.0%	0.0%
Bicycles on Crosswalk	0	0	0	0	0	0	0	0	0	0	0	0	1	2	0	0	0	0	0	1	0	0	0	0	0	0	0	0	0
% Bicycles on Crosswalk	0.0%	0.0%	0.0%	0.0%	0.0%	0.0%	0.0%	0.0%	0.0%	0.0%	0.0%	0.0%	20.0%	50.0%	0.0%	0.0%	0.0%	0.0%	0.0%	16.7%	0.0%	0.0%	0.0%	0.0%	0.0%	0.0%	0.0%	0.0%	0.0%

Project : VBH Malta NY
 Site : Site 4
 Location : 42.948550, -73.790036
 Survey Date : 2021-04-28, Wednesday

Turning Movement Data Plot

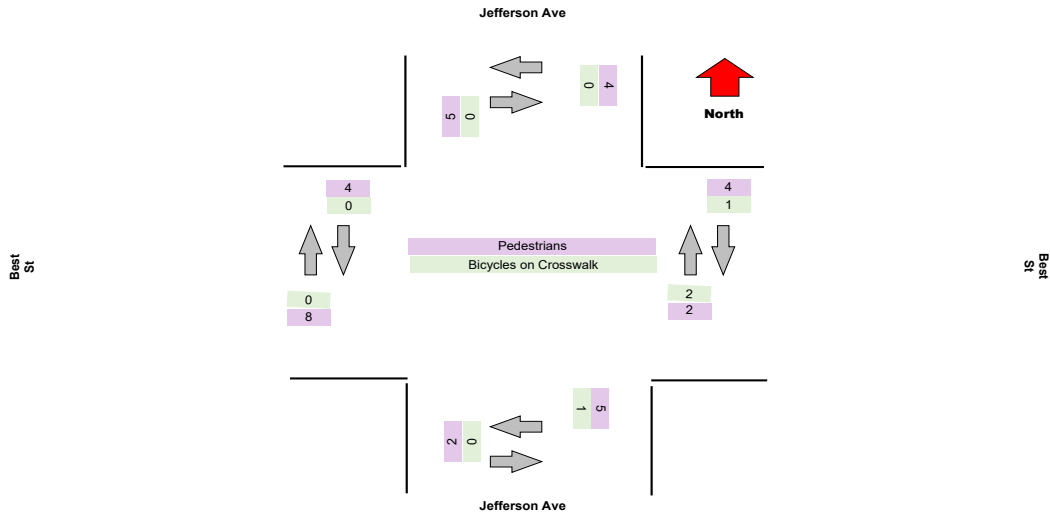
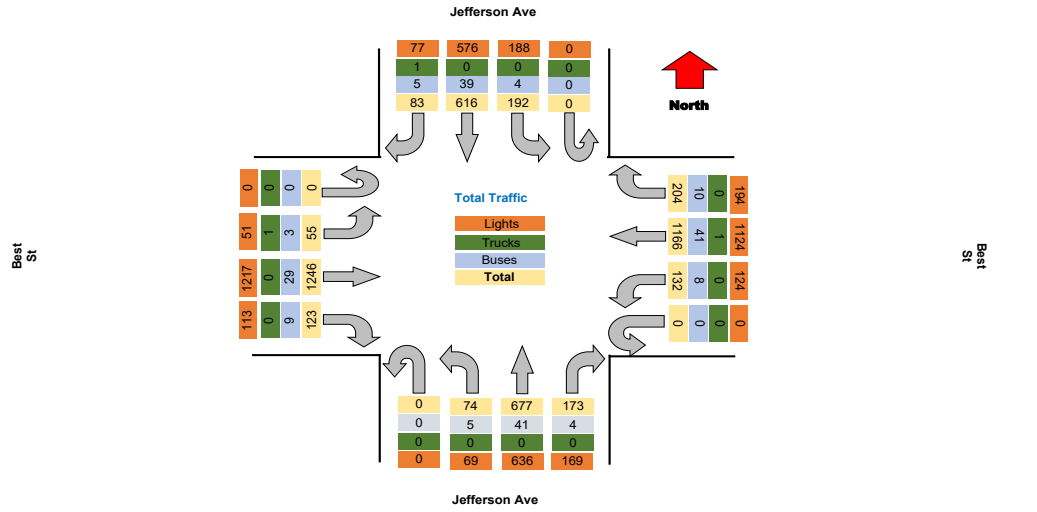

Turning Movement Peak Hour Data (AM)

7:30:00 AM

Leg Direction	Jefferson Ave					Best St					Jefferson Ave					Best St					Total
	Southbound		Northbound			Westbound		Eastbound			Northbound		Eastbound								
Start Time	Right	Thru	Left	U-Turn	App Total	Peds CW	Peds CCW	Right	Thru	Left	U-Turn	App Total	Peds CW	Peds CCW	Right	Thru	Left	U-Turn	App Total	Peds CW	Peds CCW
7:30:00 AM	4	35	11	0	50	0	0	8	69	9	0	86	0	0	11	35	3	0	49	1	0
7:45:00 AM	8	29	8	0	45	0	1	20	113	17	0	151	0	0	9	42	7	0	58	0	0
8:00:00 AM	5	29	7	0	41	0	0	11	95	14	0	120	0	0	12	45	6	0	63	0	0
8:15:00 AM	6	35	7	0	48	0	1	17	85	9	0	112	0	0	8	38	2	0	48	1	0
Grand Total	23	138	33	0	194	0	2	55	392	49	0	459	0	0	40	190	18	0	248	2	0
% Approach	11.9%	71.1%	17.0%	0.0%	0.0%	0.0%	0.0%	11.9%	77.2%	10.4%	0.0%	0.0%	0.0%	0.0%	18.3%	73.4%	8.3%	0.0%	0.0%	0.0%	0.0%
% Total	1.8%	10.7%	2.6%	0.0%	15.0%	0.0%	0.0%	4.3%	28.0%	3.8%	0.0%	36.3%	0.0%	0.0%	3.1%	12.4%	1.4%	0.0%	16.9%	0.0%	0.0%
PHF	0.719	0.885	0.750	0.000	0.951	0.000	0.000	0.700	0.801	0.721	0.000	0.776	0.000	0.000	0.833	0.889	0.643	0.000	0.865	0.000	0.000
Lights	18	128	32	0	178	0	0	53	349	47	0	449	0	0	38	147	14	0	199	0	0
% Lights	78.3%	62.8%	97.0%	0.0%	91.8%	0.0%	0.0%	84.6%	96.4%	95.9%	0.0%	95.7%	0.0%	0.0%	95.0%	91.9%	77.8%	0.0%	91.3%	0.0%	0.0%
Trucks	1	0	0	0	1	0	0	0	0	0	0	0	0	0	0	0	0	0	0	0	0
% Trucks	4.3%	0.0%	0.0%	0.0%	0.5%	0.0%	0.0%	0.0%	0.0%	0.0%	0.0%	0.0%	0.0%	0.0%	0.0%	0.0%	0.0%	0.0%	0.0%	0.0%	0.0%
Buses	4	10	1	0	15	0	0	3	13	2	0	18	0	0	2	13	4	0	19	0	0
% Buses	17.4%	7.2%	3.0%	0.0%	0.0%	0.0%	0.0%	5.4%	3.6%	4.1%	0.0%	0.0%	0.0%	0.0%	5.0%	8.1%	22.2%	0.0%	0.0%	0.0%	0.0%
Pedestrians	0	0	0	0	0	0	2	0	0	0	0	0	0	2	0	0	0	0	0	0	1
% Pedestrians	0.0%	0.0%	0.0%	0.0%	0.0%	0.0%	100.0%	0.0%	0.0%	0.0%	0.0%	0.0%	0.0%	0.0%	0.0%	0.0%	0.0%	0.0%	0.0%	0.0%	100.0%
Bicycles on Crosswalk	0	0	0	0	0	0	0	0	0	0	0	0	0	0	0	0	0	0	0	0	0
% Bicycles on Crosswalk	0.0%	0.0%	0.0%	0.0%	0.0%	0.0%	0.0%	0.0%	0.0%	0.0%	0.0%	0.0%	0.0%	0.0%	0.0%	0.0%	0.0%	0.0%	0.0%	0.0%	0.0%

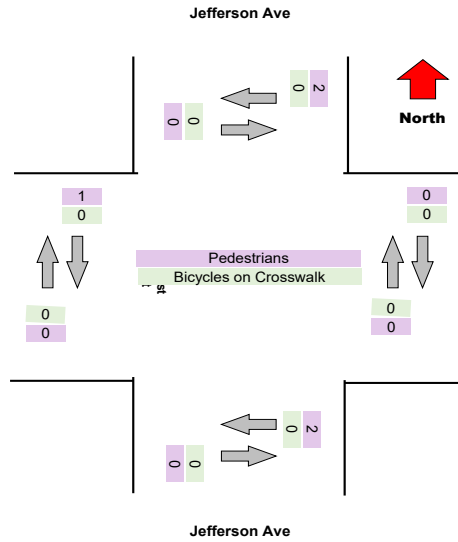
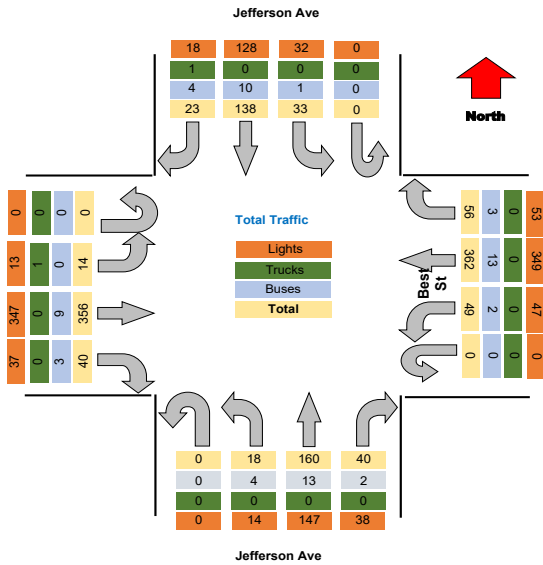

Turning Movement Peak Hour Data (PM)

4:15:00 PM

Leg Direction	Jefferson Ave										Best St				Jefferson Ave										Best St				Total	
	Southbound					Westbound					Northbound				Eastbound															
	Right	Thru	Left	U-Turn	App Total	Peds CW	Peds CCW	Right	Thru	Left	U-Turn	App Total	Peds CW	Peds CCW	Right	Thru	Left	U-Turn	App Total	Peds CW	Peds CCW	Right	Thru	Left	U-Turn	App Total	Peds CW	Peds CCW		
4:15:00 PM	5	61	12	0	78	0	0	12	71	1	0	84	0	2	11	51	6	0	68	0	0	12	97	10	0	119	0	0	349	
4:30:00 PM	6	50	20	0	76	0	0	16	49	6	0	71	0	1	19	58	7	0	84	1	0	9	104	6	0	119	1	0	350	
4:45:00 PM	5	40	18	0	63	0	0	17	56	9	0	82	0	0	10	61	8	0	79	0	1	10	96	3	0	109	0	1	333	
5:00:00 PM	10	57	15	0	82	0	0	10	65	3	0	78	0	0	11	61	5	0	77	0	0	7	103	5	0	115	0	0	352	
Grand Total	28	228	65	0	299	0	0	55	241	19	0	315	0	3	51	231	26	0	308	1	1	38	409	24	0	462	1	1	1384	
% Approach	8.7%	69.6%	21.7%	0.0%	0.0%	0.0%	0.0%	17.5%	76.5%	6.0%	0.0%	0.0%	0.0%	0.0%	16.6%	75.0%	8.4%	0.0%	0.0%	0.0%	0.0%	8.2%	86.6%	5.2%	0.0%	0.0%	0.0%	0.0%	0.0%	
% Total	1.9%	15.0%	4.7%	0.0%	21.6%	0.0%	0.0%	4.0%	17.4%	1.4%	0.0%	22.8%	0.0%	0.0%	3.7%	16.7%	1.9%	0.0%	22.3%	0.0%	0.0%	2.7%	28.9%	1.7%	0.0%	33.4%	0.0%	0.0%	0.0%	
PHF	0.650	0.852	0.613	0.000	0.912	0.000	0.000	0.809	0.849	0.528	0.000	0.938	0.000	0.000	0.671	0.947	0.813	0.000	0.917	0.000	0.000	0.792	0.962	0.600	0.000	0.971	0.000	0.000	0.983	
Lights	26	196	64	0	286	0	0	54	231	16	0	301	0	0	51	222	25	0	298	0	0	36	393	22	0	451	0	0	1336	
% Lights	100.0%	94.2%	98.5%	0.0%	95.7%	0.0%	0.0%	98.2%	95.9%	84.2%	0.0%	95.6%	0.0%	0.0%	100.0%	96.1%	96.2%	0.0%	96.8%	0.0%	0.0%	94.7%	98.3%	91.7%	0.0%	97.6%	0.0%	0.0%	96.5%	
Trucks	0	0	0	0	0	0	0	0	0	0	0	0	0	0	0	0	0	0	0	0	0	0	0	0	0	0	0	0	0	
% Trucks	0.0%	0.0%	0.0%	0.0%	0.0%	0.0%	0.0%	0.0%	0.0%	0.0%	0.0%	0.0%	0.0%	0.0%	0.0%	0.0%	0.0%	0.0%	0.0%	0.0%	0.0%	0.0%	0.0%	0.0%	0.0%	0.0%	0.0%	0.0%	0.0%	
Buses	0	12	1	0	13	0	0	1	10	3	0	14	0	0	0	9	1	0	10	0	0	2	7	2	0	11	0	0	48	
% Buses	0.0%	5.8%	1.5%	0.0%	0.0%	0.0%	0.0%	1.8%	4.1%	15.8%	0.0%	0.0%	0.0%	0.0%	0.0%	3.9%	3.8%	0.0%	0.0%	0.0%	0.0%	5.3%	1.8%	8.3%	0.0%	0.0%	0.0%	3.5%		
Pedestrians	0	0	0	0	0	0	2	0	0	0	0	2	0	0	0	0	0	1	0	0	1	0	0	0	0	0	1	1	0	
% Pedestrians	0.0%	0.0%	0.0%	0.0%	0.0%	0.0%	100.0%	0.0%	0.0%	0.0%	0.0%	0.0%	66.7%	0.0%	0.0%	0.0%	0.0%	0.0%	0.0%	0.0%	100.0%	0.0%	0.0%	0.0%	0.0%	0.0%	0.0%	100.0%	100.0%	0.0%
Bicycles on Crosswalk	0	0	0	0	0	0	0	0	0	0	0	0	1	0	0	0	0	0	1	0	0	0	0	0	0	0	0	0	0	
% Bicycles on Crosswalk	0.0%	0.0%	0.0%	0.0%	0.0%	0.0%	0.0%	0.0%	0.0%	0.0%	0.0%	0.0%	33.3%	0.0%	0.0%	0.0%	0.0%	0.0%	0.0%	100.0%	0.0%	0.0%	0.0%	0.0%	0.0%	0.0%	0.0%	0.0%	0.0%	

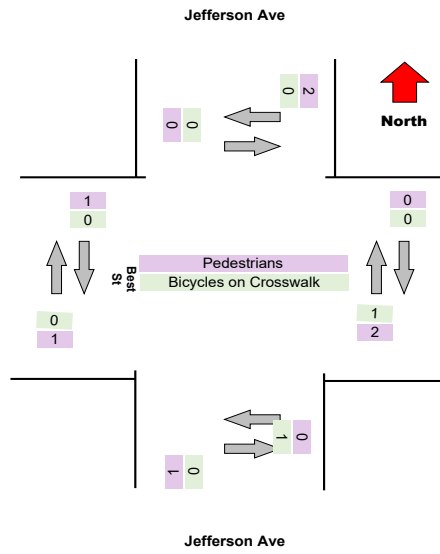
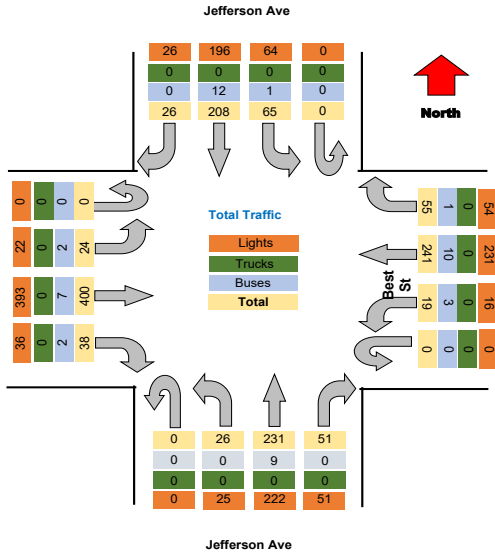

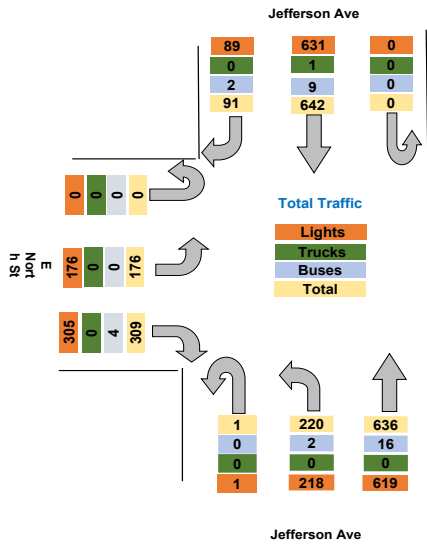

Turning Movement Data Plot

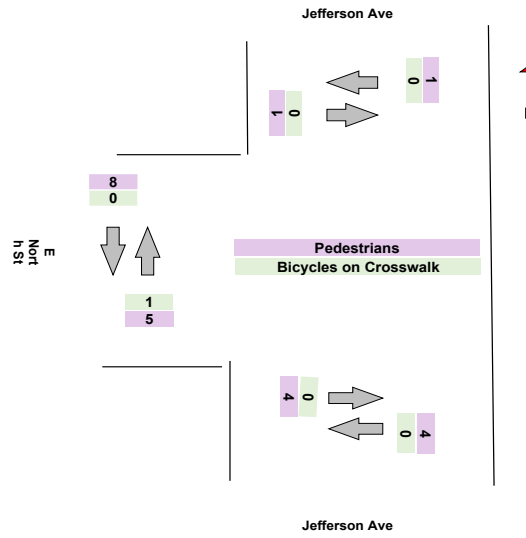

Turning Movement Peak Hour Data (AM)

7:30:00 AM

Leg Direction	Jefferson Ave Southbound						Jefferson Ave NorthBound						E North St Eastbound			
	Right	Thru	U-Turn	App Total	Peds CW	Peds CCW	Thru	Left	U-Turn	App Total	Peds CW	Peds CCW	Right	Left	U-Turn	App Total
7:30:00 AM	9	21	0	30	0	0	31	19	0	50	0	0	13	10	0	23
7:45:00 AM	6	31	0	37	0	0	24	21	0	45	0	0	7	3	0	10
8:00:00 AM	6	34	0	40	0	0	37	22	0	59	0	0	8	6	0	14
8:15:00 AM	4	35	0	39	0	0	21	17	0	38	0	0	8	8	0	16
Grand Total	25	121	0	146	0	0	113	79	0	192	0	0	36	27	0	63
% Approach	17.1%	82.9%	0.0%	0.0%	0.0%	0.0%	58.9%	41.1%	0.0%	0.0%	0.0%	0.0%	57.1%	42.9%	0.0%	0.0%
% Total	6.2%	30.2%	0.0%	36.4%	0.0%	0.0%	28.2%	19.7%	0.0%	47.9%	0.0%	0.0%	9.0%	6.7%	0.0%	15.7%
PHF	0.694	0.864	0.000	0.913	0.000	0.000	0.764	0.898	0.000	0.814	0.000	0.000	0.692	0.675	0.000	0.685
Lights	23	119	0	142	0	0	110	78	0	188	0	0	35	27	0	62
% Lights	92.0%	98.3%	0.0%	97.3%	0.0%	0.0%	97.3%	98.7%	0.0%	97.9%	0.0%	0.0%	97.2%	100.0%	0.0%	98.4%
Trucks	0	0	0	0	0	0	0	0	0	0	0	0	0	0	0	0
% Trucks	0.0%	0.0%	0.0%	0.0%	0.0%	0.0%	0.0%	0.0%	0.0%	0.0%	0.0%	0.0%	0.0%	0.0%	0.0%	0.0%
Buses	2	2	0	4	0	0	3	1	0	4	0	0	1	0	0	1
% Buses	8.0%	1.7%	0.0%	0.0%	0.0%	0.0%	2.7%	1.3%	0.0%	0.0%	0.0%	0.0%	2.8%	0.0%	0.0%	0.0%
Pedestrians	0	0	0	0	0	0	0	0	0	0	0	0	0	0	0	0
% Pedestrians	0.0%	0.0%	0.0%	0.0%	0.0%	0.0%	0.0%	0.0%	0.0%	0.0%	0.0%	0.0%	0.0%	0.0%	0.0%	0.0%
Bicycles on Crosswalk	0	0	0	0	0	0	0	0	0	0	0	0	0	0	0	0
% Bicycles on Crosswalk	0.0%	0.0%	0.0%	0.0%	0.0%	0.0%	0.0%	0.0%	0.0%	0.0%	0.0%	0.0%	0.0%	0.0%	0.0%	0.0%

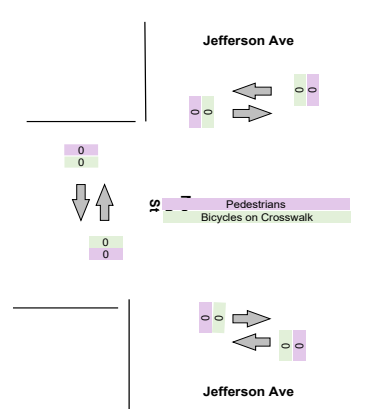
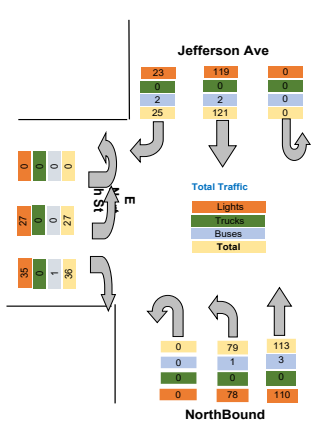

Turning Movement Peak Hour Data (PM)

4:15:00 PM

Leg Direction	Jefferson Ave Southbound						Jefferson Ave Northbound						E North St Eastbound			
	Right	Thru	U-Turn	App Total	Peds CW	Peds CCW	Thru	Left	U-Turn	App Total	Peds CW	Peds CCW	Right	Left	U-Turn	App Total
4:15:00 PM	4	55	0	59	0	0	46	11	0	57	0	0	31	16	0	47
4:30:00 PM	5	68	0	73	0	0	58	10	0	68	1	0	47	25	0	72
4:45:00 PM	3	54	0	57	0	0	64	5	1	70	1	1	27	14	0	41
5:00:00 PM	6	56	0	62	0	1	72	13	0	85	0	1	34	18	0	52
Grand Total	18	233	0	251	0	1	240	39	1	280	2	2	139	73	0	212
% Approach	7.2%	92.8%	0.0%	0.0%	0.0%	0.0%	85.7%	13.9%	0.4%	0.0%	0.0%	0.0%	65.6%	34.4%	0.0%	0.0%
% Total	2.4%	31.4%	0.0%	33.8%	0.0%	0.0%	32.3%	5.2%	0.1%	37.7%	0.0%	0.0%	18.7%	9.8%	0.0%	28.5%
PHF	0.750	0.857	0.000	0.860	0.000	0.000	0.833	0.750	0.250	0.824	0.000	0.000	0.739	0.730	0.000	0.736
Lights	18	228	0	246	0	0	233	39	1	273	0	0	138	73	0	211
% Lights	100.0%	97.9%	0.0%	98.0%	0.0%	0.0%	97.1%	100.0%	100.0%	97.5%	0.0%	0.0%	99.3%	100.0%	0.0%	99.5%
Trucks	0	1	0	1	0	0	0	0	0	0	0	0	0	0	0	0
% Trucks	0.0%	0.4%	0.0%	0.4%	0.0%	0.0%	0.0%	0.0%	0.0%	0.0%	0.0%	0.0%	0.0%	0.0%	0.0%	0.0%
Buses	0	3	0	3	0	0	6	0	0	6	0	0	1	0	0	1
% Buses	0.0%	1.3%	0.0%	0.0%	0.0%	0.0%	2.5%	0.0%	0.0%	0.0%	0.0%	0.0%	0.7%	0.0%	0.0%	0.0%
Pedestrians	0	0	0	0	0	1	0	0	0	0	2	2	0	0	0	0
% Pedestrians	0.0%	0.0%	0.0%	0.0%	0.0%	100.0%	0.0%	0.0%	0.0%	0.0%	100.0%	100.0%	0.0%	0.0%	0.0%	0.0%
Bicycles on Crosswalk	0	0	0	0	0	0	0	0	0	0	0	0	0	0	0	0
% Bicycles on Crosswalk	0.0%	0.0%	0.0%	0.0%	0.0%	0.0%	0.0%	0.0%	0.0%	0.0%	0.0%	0.0%	0.0%	0.0%	0.0%	0.0%

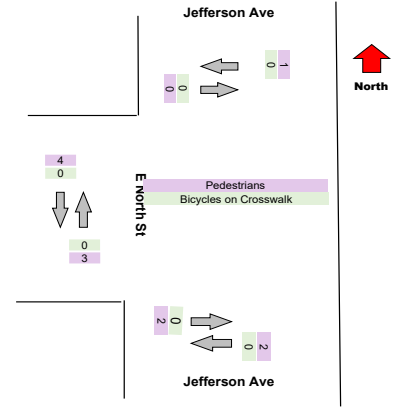
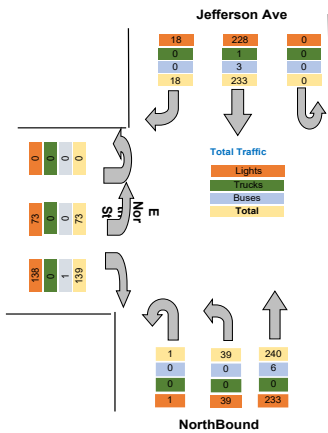

Intersection: Elm St Pine St
 Location: Kennett Square, PA
 Site: 01
 Survey Date: Wednesday, 04-28-2021
 GPS: 42.948550, -72.790034

Peds CW	Peds CCW	Total
0	0	53
0	0	84
0	0	137
0	0	64
0	0	72
0	0	103
0	0	92
0	0	331
0	0	113
0	0	93
0	0	206
0	0	189
1	0	163
1	1	213
1	2	168
3	3	733
0	1	199
1	1	188
0	1	145
2	2	137
3	5	669
6	8	2076
0.0%	0.0%	0.0%
0.0%	0.0%	0.0%
0	0	2039
0.0%	0.0%	98.2%
0	0	1
0.0%	0.0%	0.0%
0	0	33
0.0%	0.0%	1.6%
5	8	0
63.3%	100.0%	0.0%
1	0	0
16.7%	0.0%	0.0%

Intersection: Elm St Pine St
 Location: Kennett Square, PA
 Site: 01
 Survey Date: Wednesday, 04-28-2021
 GPS: 42.948550, -72.790034

Peds CW	Peds CCW	Total
0	0	103
0	0	92
0	0	113
0	0	93
0	0	401
0.0%	0.0%	
0.0%	0.0%	
0.000	0.000	0.887
0	0	392
0.0%	0.0%	97.8%
0	0	0
0.0%	0.0%	0.0%
0	0	9
0.0%	0.0%	2.2%
0	0	0
0.0%	0.0%	0.0%
0	0	0
0.0%	0.0%	0.0%

Intersection: Elm St Pine St
 Location: Kennett Square, PA
 Site: 01
 Survey Date: Wednesday, 04-28-2021
 GPS: 42.948550, -72.790034



Peds CW	Peds CCW	Total
1	0	163
1	1	213
1	2	168
0	1	199
3	4	743
0.0%	0.0%	
0.0%	0.0%	
0.000	0.000	0.872
0	0	730
0.0%	0.0%	98.3%
0	0	1
0.0%	0.0%	0.1%
0	0	10
0.0%	0.0%	1.3%
3	4	0
100.0%	100.0%	0.0%
0	0	0
0.0%	0.0%	0.0%

Project	LaBella
Project Code	LaBella
Site Name	37
Legs and Movements	All Processed Legs & Movements
Bin Size	15 minutes
Survey Date	2021-11-03, Wednesday
Location	37
Latitude and Longitude	42.902086, -78.853994

	Start	End	PHF
Forced Peak AM	2021/11/03 07:30:00	2021/11/03 08:30:00	0.826829268
Forced Peak PM	2021/11/03 16:30:00	2021/11/03 17:30:00	0.904816514
AM Peak	2021/11/03 07:30:00	2021/11/03 08:30:00	0.826829268
PM Peak	2021/11/03 16:15:00	2021/11/03 17:15:00	0.926605505

Turning Movement Data

Leg Direction	Jefferson Ave Southbound						Jefferson Ave Northbound						E North St Eastbound			
	Right	Thru	U-Turn	App Total	Peds CW	Peds CCW	Thru	Left	U-Turn	App Total	Peds CW	Peds CCW	Right	Left	U-Turn	App Total
Start Time																
6:30:00 AM	7	9	0	16	0	0	18	12	0	30	0	0	6	1	0	7
6:45:00 AM	9	19	0	28	0	0	28	23	0	51	0	0	8	1	0	9
Hourly Total	16	28	0	44	0	0	46	35	0	81	0	0	14	2	0	16
7:00:00 AM	11	29	0	40	0	0	29	25	0	54	0	0	10	5	0	15
7:15:00 AM	14	33	0	47	0	0	30	42	0	72	0	0	7	6	0	13
7:30:00 AM	10	34	0	44	0	0	33	42	0	75	2	0	19	11	0	32
7:45:00 AM	25	52	0	77	0	0	42	54	0	96	0	0	15	17	0	32
Hourly Total	60	148	0	208	0	0	134	163	0	297	2	0	51	39	0	92
8:00:00 AM	11	66	0	77	0	0	35	46	0	81	1	0	23	18	0	42
8:15:00 AM	4	41	0	45	0	0	39	15	0	54	0	0	14	9	0	23
Hourly Total	15	107	0	122	0	0	74	61	0	135	1	0	37	27	0	65
4:00:00 PM	4	58	0	62	0	0	77	13	0	90	0	2	46	22	0	68
4:15:00 PM	2	69	0	71	0	0	68	10	0	78	0	1	34	19	0	53
4:30:00 PM	10	71	0	81	0	0	55	14	0	69	2	0	36	15	0	51
4:45:00 PM	2	58	0	60	0	0	70	5	0	75	0	0	31	21	0	52
Hourly Total	18	256	0	274	0	0	270	42	0	312	2	3	147	77	0	224
5:00:00 PM	6	77	0	83	0	0	74	12	1	87	0	0	29	19	0	48
5:15:00 PM	5	57	0	62	0	0	64	15	0	79	0	0	30	12	0	42
5:30:00 PM	6	52	0	58	0	0	61	9	0	70	0	0	19	19	0	38
5:45:00 PM	4	64	0	68	0	0	53	20	0	73	0	0	21	11	0	32
Hourly Total	21	250	0	271	0	0	252	56	1	309	0	0	99	61	0	160
Grand Total	130	789	0	919	0	0	776	357	1	1134	5	3	348	206	0	557
% Approach	14.1%	85.9%	0.0%	0.0%	0.0%	0.0%	68.4%	31.5%	0.1%	0.0%	0.0%	0.0%	62.5%	37.0%	0.0%	0.0%
% Total	5.0%	30.2%	0.0%	35.2%	0.0%	0.0%	29.7%	13.7%	0.0%	43.4%	0.0%	0.0%	13.3%	7.9%	0.0%	21.3%
Lights	124	734	0	858	0	0	733	349	1	1083	0	0	334	195	0	529
% Lights	95.4%	93.0%	0.0%	93.4%	0.0%	0.0%	94.5%	97.8%	100.0%	95.8%	0.0%	0.0%	96.0%	94.7%	0.0%	95.0%
Trucks	0	1	0	1	0	0	1	0	0	1	0	0	0	0	0	0
% Trucks	0.0%	0.1%	0.0%	0.1%	0.0%	0.0%	0.1%	0.0%	0.0%	0.1%	0.0%	0.0%	0.0%	0.0%	0.0%	0.0%
Buses	6	54	0	60	0	0	42	8	0	50	0	0	14	11	0	25
% Buses	4.6%	6.8%	0.0%	0.0%	0.0%	0.0%	0.0%	2.2%	0.0%	0.0%	0.0%	0.0%	4.0%	5.3%	0.0%	0.0%
Pedestrians	0	0	0	0	0	0	0	0	0	0	5	2	0	0	0	0
% Pedestrians	0.0%	0.0%	0.0%	0.0%	0.0%	0.0%	0.0%	0.0%	0.0%	0.0%	100.0%	66.7%	0.0%	0.0%	0.0%	0.0%
Bicycles on Crosswalk	0	0	0	0	0	0	0	0	0	0	0	1	0	0	0	0
% Bicycles on Crosswalk	0.0%	0.0%	0.0%	0.0%	0.0%	0.0%	0.0%	0.0%	0.0%	0.0%	0.0%	33.3%	0.0%	0.0%	0.0%	0.0%

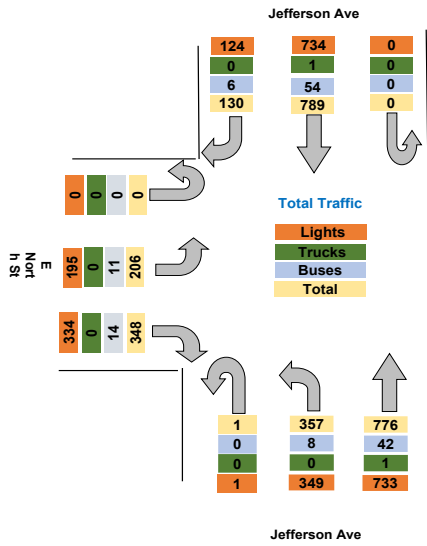

Turning Movement Data Plot

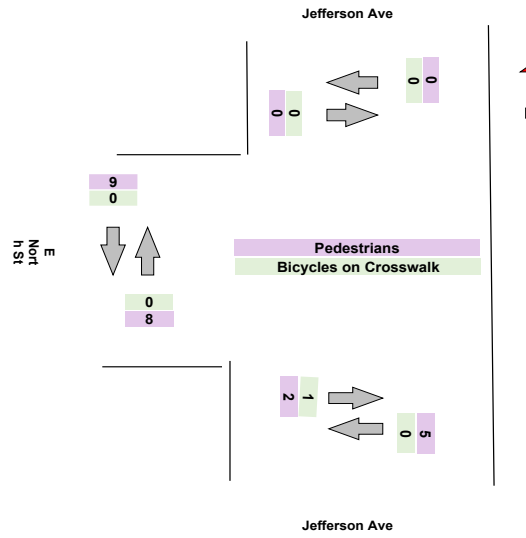

Turning Movement Peak Hour Data (AM)

7:30:00 AM

Leg Direction	Jefferson Ave Southbound						Jefferson Ave NorthBound						E North St Eastbound			
	Right	Thru	U-Turn	App Total	Peds CW	Peds CCW	Thru	Left	U-Turn	App Total	Peds CW	Peds CCW	Right	Left	U-Turn	App Total
7:30:00 AM	10	34	0	44	0	0	33	42	0	75	2	0	19	11	0	32
7:45:00 AM	25	52	0	77	0	0	42	54	0	96	0	0	15	17	0	32
8:00:00 AM	11	66	0	77	0	0	35	46	0	81	1	0	23	18	0	42
8:15:00 AM	4	41	0	45	0	0	39	15	0	54	0	0	14	9	0	23
Grand Total	50	193	0	243	0	0	149	157	0	306	3	0	71	55	0	129
% Approach	20.6%	79.4%	0.0%	0.0%	0.0%	0.0%	48.7%	51.3%	0.0%	0.0%	0.0%	0.0%	55.0%	42.6%	0.0%	0.0%
% Total	7.4%	28.5%	0.0%	35.8%	0.0%	0.0%	22.0%	23.2%	0.0%	45.1%	0.0%	0.0%	10.5%	8.1%	0.0%	19.0%
PHF	0.500	0.731	0.000	0.789	0.000	0.000	0.887	0.727	0.000	0.797	0.000	0.000	0.772	0.764	0.000	0.768
Lights	47	171	0	218	0	0	133	154	0	287	0	0	65	48	0	113
% Lights	94.0%	88.6%	0.0%	89.7%	0.0%	0.0%	89.3%	98.1%	0.0%	93.8%	0.0%	0.0%	91.5%	87.3%	0.0%	87.6%
Trucks	0	0	0	0	0	0	0	0	0	0	0	0	0	0	0	0
% Trucks	0.0%	0.0%	0.0%	0.0%	0.0%	0.0%	0.0%	0.0%	0.0%	0.0%	0.0%	0.0%	0.0%	0.0%	0.0%	0.0%
Buses	3	22	0	25	0	0	16	3	0	19	0	0	6	7	0	13
% Buses	6.0%	11.4%	0.0%	0.0%	0.0%	0.0%	10.7%	1.9%	0.0%	0.0%	0.0%	0.0%	8.5%	12.7%	0.0%	0.0%
Pedestrians	0	0	0	0	0	0	0	0	0	3	0	0	0	0	0	0
% Pedestrians	0.0%	0.0%	0.0%	0.0%	0.0%	0.0%	0.0%	0.0%	0.0%	100.0%	0.0%	0.0%	0.0%	0.0%	0.0%	0.0%
Bicycles on Crosswalk	0	0	0	0	0	0	0	0	0	0	0	0	0	0	0	0
% Bicycles on Crosswalk	0.0%	0.0%	0.0%	0.0%	0.0%	0.0%	0.0%	0.0%	0.0%	0.0%	0.0%	0.0%	0.0%	0.0%	0.0%	0.0%

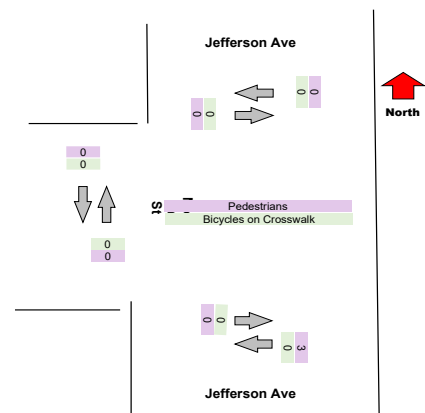
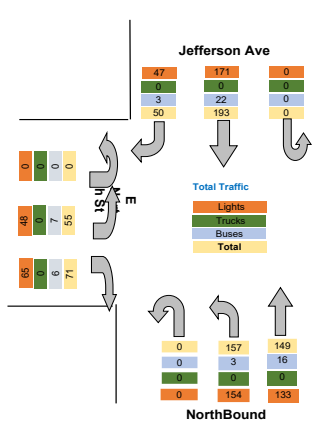

Turning Movement Peak Hour Data (PM)

4:15:00 PM

Leg Direction	Jefferson Ave Southbound						Jefferson Ave Northbound						E North St Eastbound			
	Right	Thru	U-Turn	App Total	Peds CW	Peds CCW	Thru	Left	U-Turn	App Total	Peds CW	Peds CCW	Right	Left	U-Turn	App Total
4:15:00 PM	2	69	0	71	0	0	68	10	0	78	0	1	34	19	0	53
4:30:00 PM	10	71	0	81	0	0	55	14	0	69	2	0	36	15	0	51
4:45:00 PM	2	58	0	60	0	0	70	5	0	75	0	0	31	21	0	52
5:00:00 PM	6	77	0	83	0	0	74	12	1	87	0	0	29	19	0	48
Grand Total	20	275	0	295	0	0	267	41	1	309	2	1	130	74	0	204
% Approach	6.8%	93.2%	0.0%	0.0%	0.0%	0.0%	86.4%	13.3%	0.3%	0.0%	0.0%	0.0%	63.7%	36.3%	0.0%	0.0%
% Total	2.5%	34.0%	0.0%	36.5%	0.0%	0.0%	33.0%	5.1%	0.1%	38.2%	0.0%	0.0%	16.1%	9.2%	0.0%	25.2%
PHF	0.500	0.893	0.000	0.889	0.000	0.000	0.902	0.732	0.250	0.888	0.000	0.000	0.903	0.881	0.000	0.962
Lights	17	264	0	281	0	0	257	39	1	297	0	0	127	71	0	198
% Lights	85.0%	96.0%	0.0%	95.3%	0.0%	0.0%	96.3%	95.1%	100.0%	96.1%	0.0%	0.0%	97.7%	95.9%	0.0%	97.1%
Trucks	0	0	0	0	0	0	0	0	0	0	0	0	0	0	0	0
% Trucks	0.0%	0.0%	0.0%	0.0%	0.0%	0.0%	0.0%	0.0%	0.0%	0.0%	0.0%	0.0%	0.0%	0.0%	0.0%	0.0%
Buses	3	11	0	14	0	0	10	2	0	12	0	0	3	0	0	6
% Buses	15.0%	4.0%	0.0%	0.0%	0.0%	0.0%	3.7%	4.9%	0.0%	0.0%	0.0%	0.0%	2.3%	4.1%	0.0%	0.0%
Pedestrians	0	0	0	0	0	0	0	0	0	0	2	1	0	0	0	0
% Pedestrians	0.0%	0.0%	0.0%	0.0%	0.0%	0.0%	0.0%	0.0%	0.0%	0.0%	100.0%	100.0%	0.0%	0.0%	0.0%	0.0%
Bicycles on Crosswalk	0	0	0	0	0	0	0	0	0	0	0	0	0	0	0	0
% Bicycles on Crosswalk	0.0%	0.0%	0.0%	0.0%	0.0%	0.0%	0.0%	0.0%	0.0%	0.0%	0.0%	0.0%	0.0%	0.0%	0.0%	0.0%

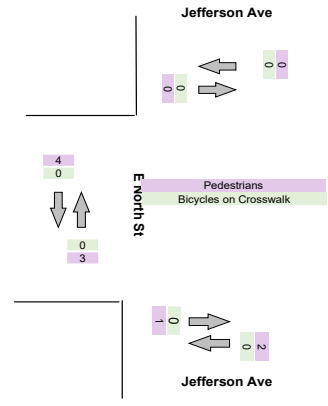
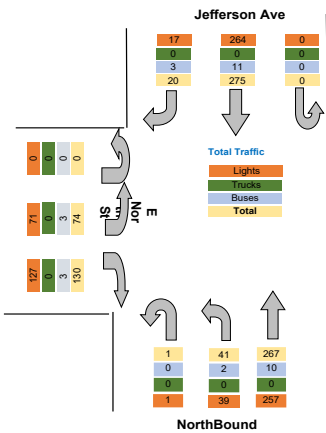

Intersection: Elm St Pine St
 Location: Kennett Square, PA
 Site: 01
 Survey Date: Wednesday, 04-28-2021
 GPS: 42.948550, -72.790034

Peds CW	Peds CCW	Total
0	0	53
1	0	88
1	0	141
0	0	109
0	0	132
0	0	151
0	0	205
0	0	597
0	0	200
0	0	122
0	0	322
0	1	220
0	1	202
0	0	201
1	0	187
1	2	810
2	3	218
2	3	183
1	0	166
1	1	173
6	7	740
8	9	2610
0.0%	0.0%	0.0%
0.0%	0.0%	0.0%
0	0	2470
0.0%	0.0%	94.6%
0	0	2
0.0%	0.0%	0.1%
0	0	135
0.0%	0.0%	5.2%
8	9	0
100.0%	100.0%	0.0%
0	0	0
0.0%	0.0%	0.0%

Intersection: Elm St Pine St
 Location: Kennett Square, PA
 Site: 01
 Survey Date: Wednesday, 04-28-2021
 GPS: 42.948550, -72.790034



Peds CW	Peds CCW	Total
0	0	151
0	0	205
0	0	200
0	0	122
0	0	678
0.0%	0.0%	
0.0%	0.0%	
0.000	0.000	0.827
0	0	618
0.0%	0.0%	91.2%
0	0	0
0.0%	0.0%	0.0%
0	0	57
0.0%	0.0%	8.4%
0	0	0
0.0%	0.0%	0.0%
0	0	0
0.0%	0.0%	0.0%

Intersection: Elm St Pine St
 Location: Kennett Square, PA
 Site: 01
 Survey Date: Wednesday, 04-28-2021
 GPS: 42.948550, -72.790034



Peds CW	Peds CCW	Total
0	1	202
0	0	201
1	0	187
2	3	218
3	4	808
0.0%	0.0%	
0.0%	0.0%	
0.000	0.000	0.927
0	0	776
0.0%	0.0%	96.0%
0	0	0
0.0%	0.0%	0.0%
0	0	32
0.0%	0.0%	4.0%
3	4	0
100.0%	100.0%	0.0%
0	0	0
0.0%	0.0%	0.0%

Intersection: Elm St Pine St
 Location: Kennett Square, PA
 Site: 01
 Survey Date: Wednesday, 04-28-2021
 GPS: 42.948550, -72.790034



Project	LaBella
Project Code	LaBella
Site Name	37
Legs and Movements	All Processed Legs & Movements
Bin Size	15 minutes
Survey Date	2021-11-04, Thursday
Location	37
Latitude and Longitude	42.902086, -78.853994

	Start	End	PHF
Forced Peak AM	2021/11/04 07:30:00	2021/11/04 08:30:00	0.25
Forced Peak PM	2021/11/04 16:30:00	2021/11/04 17:30:00	0.25
AM Peak	2021/11/04 07:30:00	2021/11/04 08:30:00	0.25
PM Peak	2021/11/04 16:15:00	2021/11/04 17:15:00	0.25

Turning Movement Data

Leg Direction	Jefferson Ave Southbound						Jefferson Ave Northbound						E North St Eastbound										
	Right	Thru	U-Turn	App Total	Peds	CW	Peds	CCW	Thru	Left	U-Turn	App Total	Peds	CW	Peds	CCW	Right	Left	U-Turn	App Total	Peds	CW	
Start Time	11	18	0	29	0	0	19	17	0	36	0	0	11	0	0	11	0	0	11	0	0	11	0
6:30:00 AM	9	17	0	26	0	0	25	25	0	50	0	0	8	4	0	12	1	0	12	1	0	12	1
6:45:00 AM	20	35	0	55	0	0	44	42	0	86	0	0	19	4	0	23	1	0	23	1	0	23	1
Hourly Total	5	18	0	23	0	0	24	26	0	50	0	0	8	3	0	11	0	0	11	0	0	11	0
7:00:00 AM	11	30	0	41	0	0	23	29	0	52	0	0	9	8	0	17	0	0	17	0	0	17	0
7:15:00 AM	11	45	0	56	0	0	39	52	0	91	1	0	16	10	0	27	0	0	27	0	0	27	0
7:30:00 AM	21	32	0	53	0	0	48	58	0	106	0	0	19	12	0	31	0	0	31	0	0	31	0
7:45:00 AM	48	125	0	173	0	0	134	165	0	299	1	0	52	33	0	86	0	0	86	0	0	86	0
Hourly Total	15	56	0	71	0	0	48	52	0	100	1	0	25	14	0	40	0	0	40	0	0	40	0
8:00:00 AM	8	45	0	53	0	0	39	20	0	59	0	0	13	9	0	22	0	0	22	0	0	22	0
8:15:00 AM	23	101	0	124	0	0	87	72	0	159	1	0	38	23	0	62	0	0	62	0	0	62	0
Hourly Total	4	76	0	80	0	0	54	17	0	71	0	0	49	17	0	66	2	0	66	2	0	66	2
4:00:00 PM	7	67	0	74	0	0	57	14	0	71	0	0	29	11	0	40	0	0	40	0	0	40	0
4:15:00 PM	5	60	0	65	0	0	71	5	0	76	0	0	40	16	0	56	2	0	56	2	0	56	2
4:30:00 PM	3	55	0	58	0	0	68	11	0	79	0	2	29	14	0	43	1	0	43	1	0	43	1
4:45:00 PM	19	258	0	277	0	0	250	47	0	297	0	2	147	58	0	205	5	0	205	5	0	205	5
Hourly Total	5	63	0	68	0	0	63	14	0	77	1	0	30	12	0	42	2	0	42	2	0	42	2
5:00:00 PM	5	60	0	65	0	0	55	12	0	67	0	0	27	10	0	37	0	0	37	0	0	37	0
5:15:00 PM	3	59	0	62	0	0	64	14	0	78	0	0	25	15	0	40	1	0	40	1	0	40	1
5:30:00 PM	3	50	0	53	0	0	63	4	0	67	0	0	18	17	0	35	0	0	35	0	0	35	0
5:45:00 PM	16	232	0	248	0	0	245	44	0	289	1	0	100	54	0	154	3	0	154	3	0	154	3
Hourly Total	126	751	0	877	0	0	760	370	0	1130	3	2	356	172	0	530	9	0	530	9	0	530	9
Grand Total	14.4%	85.6%	0.0%	0.0%	0.0%	0.0%	67.3%	32.7%	0.0%	0.0%	0.0%	0.0%	67.2%	32.5%	0.0%	0.0%	0.0%	14.0%	6.8%	0.0%	20.9%	0.0%	
% Approach	5.0%	29.6%	0.0%	34.6%	0.0%	0.0%	30.0%	14.6%	0.0%	44.5%	0.0%	0.0%	14.0%	6.8%	0.0%	20.9%	0.0%						
% Total	122	697	0	819	0	0	715	364	0	1079	0	0	340	167	0	507	0						
Lights	96.8%	92.8%	0.0%	93.4%	0.0%	0.0%	94.1%	98.4%	0.0%	95.5%	0.0%	0.0%	95.5%	97.1%	0.0%	95.7%	0.0%						
% Lights	0	0	0	0	0	0	0	0	0	0	0	0	0	0	0	0	0						
Trucks	0.0%	0.0%	0.0%	0.0%	0.0%	0.0%	0.0%	0.0%	0.0%	0.0%	0.0%	0.0%	0.0%	0.0%	0.0%	0.0%	0.0%						
% Trucks	4	52	0	56	0	0	45	5	0	50	0	0	16	5	0	21	0						
Buses	3.2%	6.9%	0.0%	0.0%	0.0%	0.0%	0.0%	1.4%	0.0%	0.0%	0.0%	0.0%	4.5%	2.9%	0.0%	0.0%	0.0%						
% Buses	0	0	0	0	0	0	0	0	0	0	3	2	0	0	0	0	9						
Pedestrians	0.0%	0.0%	0.0%	0.0%	0.0%	0.0%	0.0%	0.0%	0.0%	0.0%	100.0%	100.0%	0.0%	0.0%	0.0%	0.0%	100.0%						
% Pedestrians	0	0	0	0	0	0	0	0	0	0	0	0	0	0	0	0	0						
Bicycles on Crosswalk	0.0%	0.0%	0.0%	0.0%	0.0%	0.0%	0.0%	0.0%	0.0%	0.0%	0.0%	0.0%	0.0%	0.0%	0.0%	0.0%	0.0%						
% Bicycles on Crosswalk																							

Turning Movement Data Plot

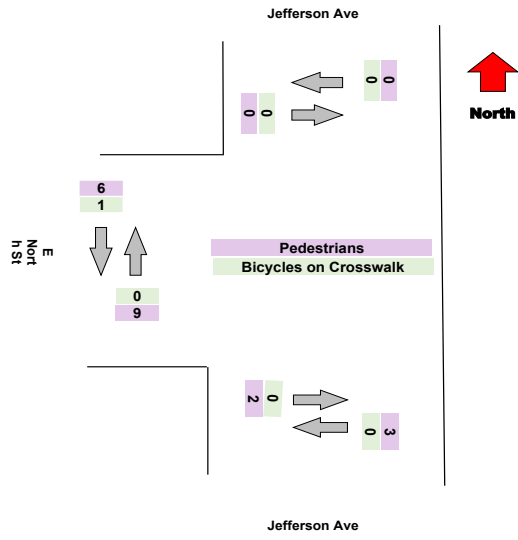
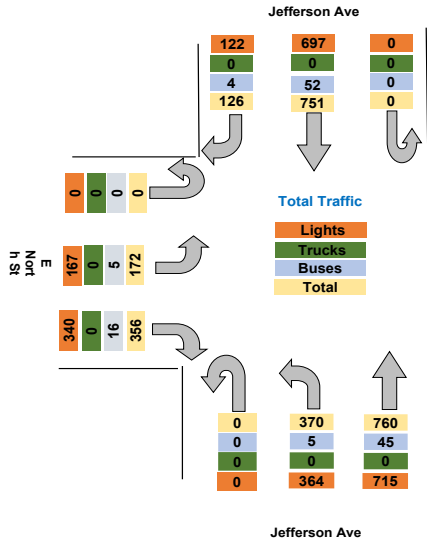

Turning Movement Peak Hour Data (AM)

7:30:00 AM

Leg Direction	Jefferson Ave Southbound						Jefferson Ave NorthBound						E North St Eastbound					
	Right	Thru	U-Turn	App Total	Peds CW	Peds CCW	Thru	Left	U-Turn	App Total	Peds CW	Peds CCW	Right	Left	U-Turn	App Total	Peds CW	
7:30:00 AM	0	0	0	0	0	0	0	0	0	0	0	0	0	0	0	0	0	0
7:45:00 AM	126	751	0	877	0	0	760	370	0	1130	3	2	356	172	0	530	9	0
8:00:00 AM	0.14367	0.85633	0	0	0	0	0.67257	0.32743	0	0	0	0	0.6717	0.32453	0	0	0	0
8:15:00 AM	0.04966	0.29602	0	0.34568	0	0	0.29957	0.14584	0	0.44541	0	0	0.14032	0.0678	0	0.20891	0	0
Grand Total	126.193	752.152	0	877.346	0	0	760.972	370.473	0	1130.45	3	2	356.812	172.392	0	530.209	9	0
% Approach	14.4%	85.7%	0.0%	0.0%	0.0%	0.0%	67.3%	32.8%	0.0%	0.0%	0.0%	0.0%	67.3%	32.5%	0.0%	0.0%	0.0%	0.0%
% Total	5.0%	29.6%	0.0%	34.6%	0.0%	0.0%	30.0%	14.6%	0.0%	44.6%	0.0%	0.0%	14.1%	6.8%	0.0%	20.9%	0.0%	0.0%
PHF	0.250	0.250	0.000	0.250	0.000	0.000	0.250	0.250	0.000	0.250	0.000	0.000	0.251	0.251	0.000	0.250	0.000	0.000
Lights	122	697	0	819	0	0	715	364	0	1079	0	0	340	167	0	507	0	0
% Lights	96.7%	92.7%	0.0%	93.3%	0.0%	0.0%	94.0%	98.3%	0.0%	95.4%	0.0%	0.0%	95.3%	96.9%	0.0%	95.6%	0.0%	0.0%
Trucks	0	0	0	0	0	0	0	0	0	0	0	0	0	0	0	0	0	0
% Trucks	0.0%	0.0%	0.0%	0.0%	0.0%	0.0%	0.0%	0.0%	0.0%	0.0%	0.0%	0.0%	0.0%	0.0%	0.0%	0.0%	0.0%	0.0%
Buses	4	52	0	56	0	0	45	5	0	50	0	0	16	5	0	21	0	0
% Buses	3.2%	6.9%	0.0%	0.0%	0.0%	0.0%	5.9%	1.3%	0.0%	0.0%	0.0%	0.0%	4.5%	2.9%	0.0%	0.0%	0.0%	0.0%
Pedestrians	0	0	0	0	0	0	0	0	0	3	2	0	0	0	0	0	0	9
% Pedestrians	0.0%	0.0%	0.0%	0.0%	0.0%	0.0%	0.0%	0.0%	0.0%	100.0%	100.0%	0.0%	0.0%	0.0%	0.0%	0.0%	0.0%	100.0%
Bicycles on Crosswalk	0	0	0	0	0	0	0	0	0	0	0	0	0	0	0	0	0	0
% Bicycles on Crosswalk	0.0%	0.0%	0.0%	0.0%	0.0%	0.0%	0.0%	0.0%	0.0%	0.0%	0.0%	0.0%	0.0%	0.0%	0.0%	0.0%	0.0%	0.0%

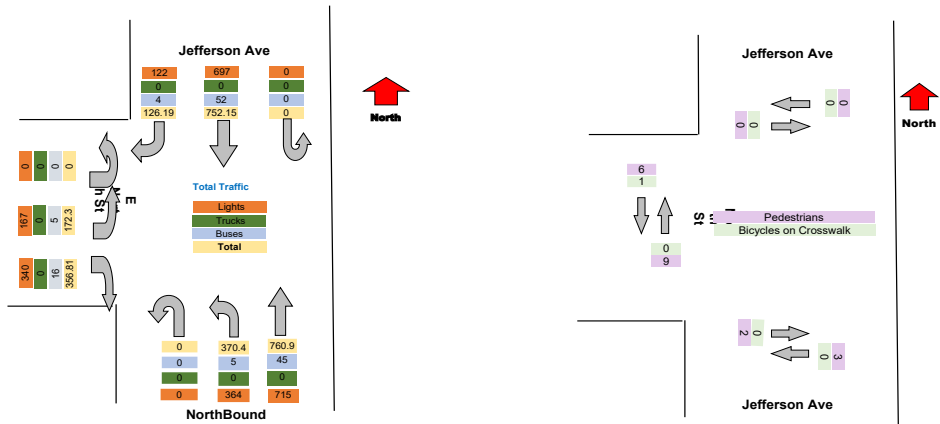

Turning Movement Peak Hour Data (PM)

4:15:00 PM

Leg Direction	Jefferson Ave Southbound						Jefferson Ave NorthBound						E North St Eastbound					
	Right	Thru	U-Turn	App Total	Peds CW	Peds CCW	Thru	Left	U-Turn	App Total	Peds CW	Peds CCW	Right	Left	U-Turn	App Total	Peds CW	
4:15:00 PM	0	0	0	0	0	0	0	0	0	0	0	0	0	0	0	0	0	
4:30:00 PM	126	751	0	877	0	0	760	370	0	1130	3	2	356	172	0	530	9	
4:45:00 PM	0.14367	0.85633	0	0	0	0	0.67257	0.32743	0	0	0	0	0.6717	0.32453	0	0	0	
5:00:00 PM	0.04966	0.29602	0	0.34568	0	0	0.29957	0.14584	0	0.44541	0	0	0.14032	0.0678	0	0.20891	0	
Grand Total	126.193	752.152	0	877.346	0	0	760.972	370.473	0	1130.45	3	2	356.812	172.392	0	530.209	9	
% Approach	14.4%	85.7%	0.0%	0.0%	0.0%	0.0%	67.3%	32.8%	0.0%	0.0%	0.0%	0.0%	67.3%	32.5%	0.0%	0.0%	0.0%	
% Total	5.0%	29.6%	0.0%	34.6%	0.0%	0.0%	30.0%	14.6%	0.0%	44.6%	0.0%	0.0%	14.1%	6.8%	0.0%	20.9%	0.0%	
PHF	0.250	0.250	0.000	0.250	0.000	0.000	0.250	0.250	0.000	0.250	0.000	0.000	0.251	0.251	0.000	0.250	0.000	
Lights	122	697	0	819	0	0	715	364	0	1079	0	0	340	167	0	507	0	
% Lights	96.7%	92.7%	0.0%	93.3%	0.0%	0.0%	94.0%	98.3%	0.0%	95.4%	0.0%	0.0%	95.3%	96.9%	0.0%	95.6%	0.0%	
Trucks	0	0	0	0	0	0	0	0	0	0	0	0	0	0	0	0	0	
% Trucks	0.0%	0.0%	0.0%	0.0%	0.0%	0.0%	0.0%	0.0%	0.0%	0.0%	0.0%	0.0%	0.0%	0.0%	0.0%	0.0%	0.0%	
Buses	4	52	0	56	0	0	45	5	0	50	0	0	16	5	0	21	0	
% Buses	3.2%	6.9%	0.0%	0.0%	0.0%	0.0%	5.9%	1.3%	0.0%	0.0%	0.0%	0.0%	4.5%	2.9%	0.0%	0.0%	0.0%	
Pedestrians	0	0	0	0	0	0	0	0	0	3	2	0	0	0	0	0	9	
% Pedestrians	0.0%	0.0%	0.0%	0.0%	0.0%	0.0%	0.0%	0.0%	0.0%	0.0%	100.0%	100.0%	0.0%	0.0%	0.0%	0.0%	100.0%	
Bicycles on Crosswalk	0	0	0	0	0	0	0	0	0	0	0	0	0	0	0	0	0	
% Bicycles on Crosswalk	0.0%	0.0%	0.0%	0.0%	0.0%	0.0%	0.0%	0.0%	0.0%	0.0%	0.0%	0.0%	0.0%	0.0%	0.0%	0.0%	0.0%	

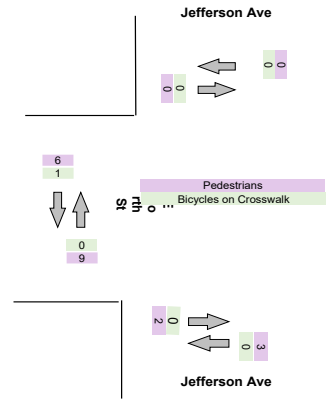
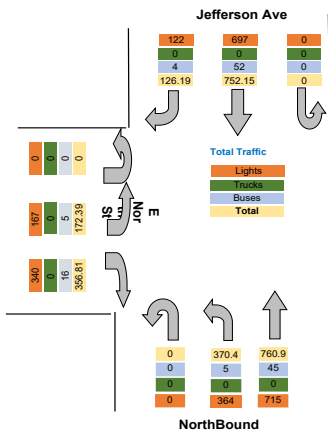

Intersection: Elm St Pine St
 Location: Kennett Square, PA
 Site: 01
 Survey Date: Wednesday, 04-28-2021
 GPS: 42.948550, -72.790034



Peds CCW	Total
0	76
0	88
0	164
0	84
0	110
0	174
0	190
0	558
0	211
0	134
0	345
1	217
0	185
1	197
1	180
3	779
1	187
0	169
1	180
2	155
4	691
7	2537
0.0%	0.0%
0.0%	0.0%
0	2405
0.0%	94.8%
0	0
0.0%	0.0%
0	127
0.0%	5.0%
6	0
85.7%	0.0%
1	0
14.3%	0.0%

Intersection: Elm St Pine St
 Location: Kennett Square, PA
 Site: 01
 Survey Date: Wednesday, 04-28-2021
 GPS: 42.948550, -72.790034



Peds CCW	Total
0	0
7	2537
0	0
0	0
7	2537
0.0%	
0.0%	
0.000	0.250
0	2405
0.0%	94.8%
0	0
0.0%	0.0%
0	127
0.0%	5.0%
6	0
85.7%	0.0%
1	0
14.3%	0.0%

Intersection: Elm St Pine St
 Location: Kennett Square, PA
 Site: 01
 Survey Date: Wednesday, 04-28-2021
 GPS: 42.948550, -72.790034



Peds CCW	Total
0	0
7	2537
0	0
0	0
7	2537
0.0%	
0.0%	
0.000	0.250
0	2405
0.0%	94.8%
0	0
0.0%	0.0%
0	127
0.0%	5.0%
6	0
85.7%	0.0%
1	0
14.3%	0.0%

Project : VBH Malta NY
 Site : Site 4
 Location : 42.948550, -73.790036
 Survey Date : 2021-04-28, Wednesday

Turning Movement Data Plot

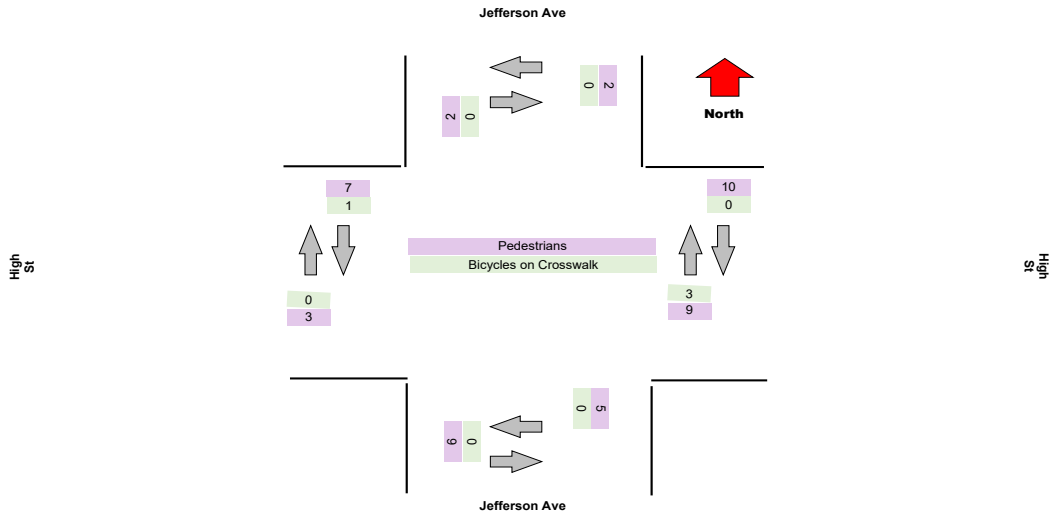
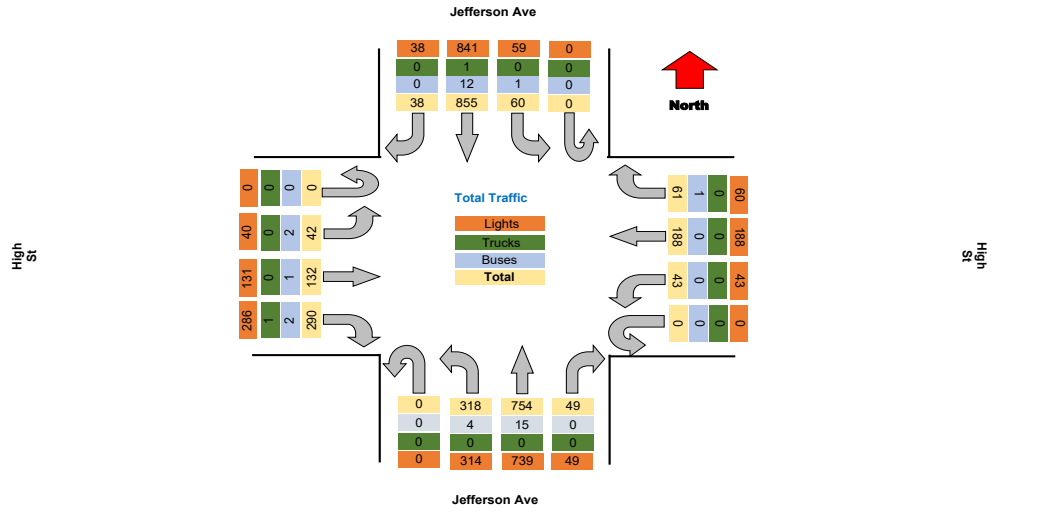

Turning Movement Peak Hour Data (AM)

7:30:00 AM

Leg Direction	Jefferson Ave						High St						Jefferson Ave						High St						Total				
	Southbound			Northbound			Westbound			Eastbound			Northbound			Eastbound													
Start Time	Right	Thru	Left	U-Turn	App Total	Peds CW	Peds CCW	Right	Thru	Left	U-Turn	App Total	Peds CW	Peds CCW	Right	Thru	Left	U-Turn	App Total	Peds CW	Peds CCW	Right	Thru	Left	U-Turn	App Total	Peds CW	Peds CCW	
7:30:00 AM	3	24	7	0	34	0	0	3	17	0	0	20	0	0	1	46	36	0	83	0	0	14	9	1	0	24	0	0	
7:45:00 AM	2	31	3	0	36	0	0	6	13	2	0	21	0	0	2	41	36	0	79	0	0	16	8	2	0	26	2	0	
8:00:00 AM	4	38	2	0	44	0	0	2	5	2	0	9	1	0	1	50	28	0	80	0	0	8	5	2	0	15	0	0	
8:15:00 AM	3	37	3	0	43	0	0	4	9	2	0	15	0	0	1	35	31	0	67	0	0	8	5	0	0	13	0	0	
Grand Total	12	100	15	0	127	0	0	15	44	6	0	65	1	0	5	172	131	0	309	0	0	46	27	5	0	78	2	0	
% Approach	7.6%	82.8%	9.6%	0.0%	0.0%	0.0%	0.0%	23.1%	67.7%	9.2%	0.0%	0.0%	0.0%	0.0%	1.6%	95.7%	42.4%	0.0%	0.0%	0.0%	0.0%	59.0%	34.6%	6.4%	0.0%	0.0%	0.0%	0.0%	
% Total	2.0%	21.3%	2.5%	0.0%	25.8%	0.0%	0.0%	2.5%	7.2%	1.0%	0.0%	10.7%	0.0%	0.0%	0.8%	28.2%	21.5%	0.0%	50.7%	0.0%	0.0%	7.6%	4.4%	0.8%	0.0%	12.8%	0.0%	0.0%	
PHF	0.750	0.855	0.536	0.000	0.892	0.000	0.000	0.625	0.647	0.750	0.000	0.774	0.000	0.000	0.625	0.860	0.910	0.000	0.831	0.000	0.000	0.719	0.750	0.625	0.000	0.750	0.000	0.000	
Lights	12	127	15	0	154	0	0	14	44	6	0	64	0	0	5	169	131	0	305	0	0	44	26	5	0	75	0	0	
% Lights	100.0%	97.7%	100.0%	0.0%	98.1%	0.0%	0.0%	83.3%	100.0%	100.0%	0.0%	98.5%	0.0%	0.0%	100.0%	98.3%	100.0%	0.0%	98.7%	0.0%	0.0%	95.7%	96.3%	100.0%	0.0%	96.2%	0.0%	0.0%	
Trucks	0	0	0	0	0	0	0	0	0	0	0	0	0	0	0	0	0	0	0	0	0	0	0	0	0	0	0	0	
% Trucks	0.0%	0.0%	0.0%	0.0%	0.0%	0.0%	0.0%	0.0%	0.0%	0.0%	0.0%	0.0%	0.0%	0.0%	0.0%	0.0%	0.0%	0.0%	0.0%	0.0%	0.0%	0.0%	0.0%	0.0%	0.0%	0.0%	0.0%	0.0%	
Buses	0	3	0	0	3	0	0	1	0	0	0	1	0	0	0	3	0	0	3	0	0	2	1	0	0	3	0	0	
% Buses	0.0%	2.3%	0.0%	0.0%	0.0%	0.0%	0.0%	6.7%	0.0%	0.0%	0.0%	0.0%	0.0%	0.0%	0.0%	1.7%	0.0%	0.0%	0.0%	0.0%	0.0%	4.3%	3.7%	0.0%	0.0%	0.0%	0.0%	1.6%	
Pedestrians	0	0	0	0	0	0	0	0	0	0	0	1	0	0	0	0	0	0	0	0	0	0	0	0	0	0	2	0	
% Pedestrians	0.0%	0.0%	0.0%	0.0%	0.0%	0.0%	0.0%	0.0%	0.0%	0.0%	0.0%	0.0%	100.0%	0.0%	0.0%	0.0%	0.0%	0.0%	0.0%	0.0%	0.0%	0.0%	0.0%	0.0%	0.0%	0.0%	0.0%	100.0%	0.0%
Bicycles on Crosswalk	0	0	0	0	0	0	0	0	0	0	0	0	0	0	0	0	0	0	0	0	0	0	0	0	0	0	0	0	
% Bicycles on Crosswalk	0.0%	0.0%	0.0%	0.0%	0.0%	0.0%	0.0%	0.0%	0.0%	0.0%	0.0%	0.0%	0.0%	0.0%	0.0%	0.0%	0.0%	0.0%	0.0%	0.0%	0.0%	0.0%	0.0%	0.0%	0.0%	0.0%	0.0%	0.0%	

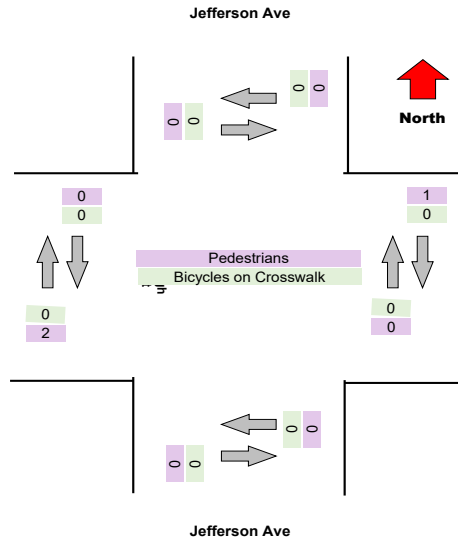
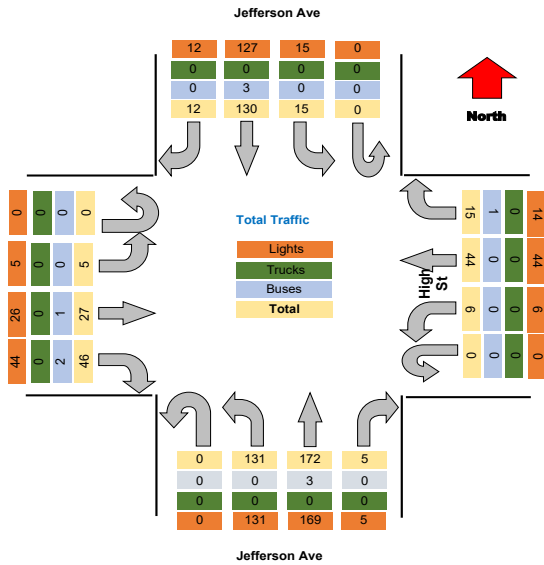

Turning Movement Peak Hour Data (PM)

4:15:00 PM

Leg Direction	Jefferson Ave								High St				Jefferson Ave				High St				Total											
	Southbound				Westbound				Northbound				Eastbound																			
	Right	Thru	Left	U-Turn	App Total	Peds CW	Peds CCW		Right	Thru	Left	U-Turn	App Total	Peds CW	Peds CCW		Right	Thru	Left	U-Turn		App Total	Peds CW	Peds CCW								
4:15:00 PM	2	83	3	0	88	1	0	0	2	10	3	0	15	0	0	0	7	49	8	0	64	0	0	0	29	8	4	0	41	0	1	208
4:30:00 PM	2	101	11	0	114	1	0	0	4	14	8	0	26	1	2	0	6	54	9	0	69	1	0	0	30	11	11	0	52	0	0	261
4:45:00 PM	3	78	1	0	82	0	0	0	4	13	4	0	21	0	0	0	1	59	18	0	78	0	2	0	18	14	3	0	35	0	3	216
5:00:00 PM	2	84	5	0	91	0	0	0	7	12	5	0	24	0	0	0	8	78	19	0	103	2	0	0	37	12	6	0	55	1	0	273
Grand Total	9	346	20	0	375	2	0	0	17	49	20	0	86	1	2	0	22	238	54	0	314	3	2	0	114	45	24	0	183	1	4	958
% Approach	2.4%	92.3%	5.3%	0.0%	0.0%	0.0%	0.0%	0.0%	19.8%	57.0%	23.3%	0.0%	0.0%	0.0%	0.0%	0.0%	7.0%	75.8%	17.2%	0.0%	0.0%	0.0%	0.0%	0.0%	62.3%	24.6%	13.1%	0.0%	0.0%	0.0%	0.0%	
% Total	0.9%	36.1%	2.1%	0.0%	38.1%	0.0%	0.0%	0.0%	1.8%	5.1%	2.1%	0.0%	9.0%	0.0%	0.0%	0.0%	2.3%	24.8%	5.6%	0.0%	32.8%	0.0%	0.0%	0.0%	11.9%	4.7%	2.5%	0.0%	19.1%	0.0%	0.0%	
PHF	0.750	0.856	0.455	0.000	0.822	0.000	0.000	0.000	0.607	0.875	0.625	0.000	0.827	0.000	0.000	0.000	0.688	0.783	0.711	0.000	0.762	0.000	0.000	0.000	0.770	0.804	0.545	0.000	0.832	0.000	0.000	0.877
Lights	9	340	20	0	369	0	0	0	17	49	20	0	86	0	0	0	22	233	53	0	308	0	0	0	113	45	23	0	181	0	0	944
% Lights	100.0%	98.3%	100.0%	0.0%	98.4%	0.0%	0.0%	0.0%	100.0%	100.0%	100.0%	0.0%	100.0%	0.0%	0.0%	0.0%	100.0%	97.0%	98.1%	0.0%	98.1%	0.0%	0.0%	0.0%	99.1%	100.0%	95.8%	0.0%	98.9%	0.0%	0.0%	98.8%
Trucks	0	1	0	0	1	0	0	0	0	0	0	0	0	0	0	0	0	0	0	0	0	0	0	0	0	0	0	0	0	0	0	1
% Trucks	0.0%	0.3%	0.0%	0.0%	0.3%	0.0%	0.0%	0.0%	0.0%	0.0%	0.0%	0.0%	0.0%	0.0%	0.0%	0.0%	0.0%	0.0%	0.0%	0.0%	0.0%	0.0%	0.0%	0.0%	0.0%	0.0%	0.0%	0.0%	0.0%	0.0%	0.0%	0.1%
Buses	0	4	0	0	4	0	0	0	0	0	0	0	0	0	0	0	0	5	1	0	6	0	0	0	0	0	0	1	0	0	0	11
% Buses	0.0%	1.2%	0.0%	0.0%	0.0%	0.0%	0.0%	0.0%	0.0%	0.0%	0.0%	0.0%	0.0%	0.0%	0.0%	0.0%	0.0%	2.1%	1.9%	0.0%	0.0%	0.0%	0.0%	0.0%	0.0%	0.0%	4.2%	0.0%	0.0%	0.0%	1.1%	
Pedestrians	0	0	0	0	0	2	0	0	0	0	0	0	0	1	3	0	0	0	0	0	3	2	0	0	0	0	0	0	1	3	0	
% Pedestrians	0.0%	0.0%	0.0%	0.0%	0.0%	100.0%	0.0%	0.0%	0.0%	0.0%	0.0%	0.0%	0.0%	100.0%	100.0%	0.0%	0.0%	0.0%	0.0%	0.0%	0.9%	100.0%	100.0%	0.0%	0.0%	0.0%	0.0%	0.0%	100.0%	75.0%	0.0%	0.0%
Bicycles on Crosswalk	0	0	0	0	0	0	0	0	0	0	0	0	0	0	0	0	0	0	0	0	0	0	0	0	0	0	0	0	0	0	1	0
% Bicycles on Crosswalk	0.0%	0.0%	0.0%	0.0%	0.0%	0.0%	0.0%	0.0%	0.0%	0.0%	0.0%	0.0%	0.0%	0.0%	0.0%	0.0%	0.0%	0.0%	0.0%	0.0%	0.0%	0.0%	0.0%	0.0%	0.0%	0.0%	0.0%	0.0%	0.0%	25.0%	0.0%	0.0%

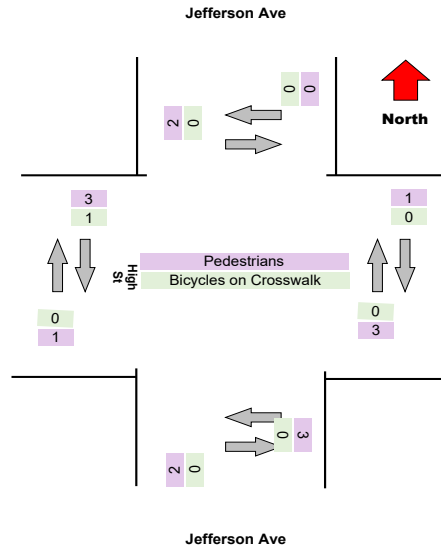
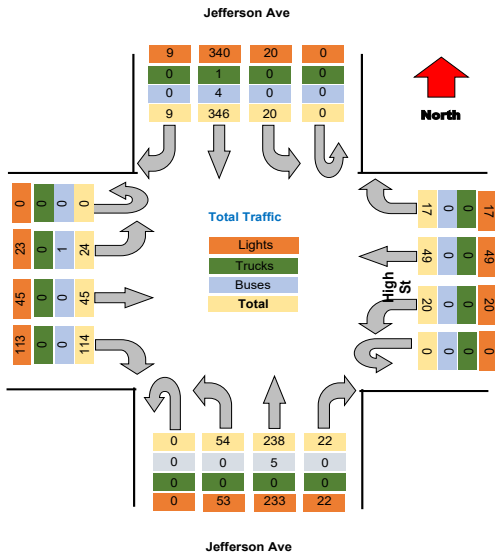

Project : VBH Malta NY
 Site : Site 4
 Location : 42.948550, -73.790036
 Survey Date : 2021-04-28, Wednesday

Turning Movement Data Plot

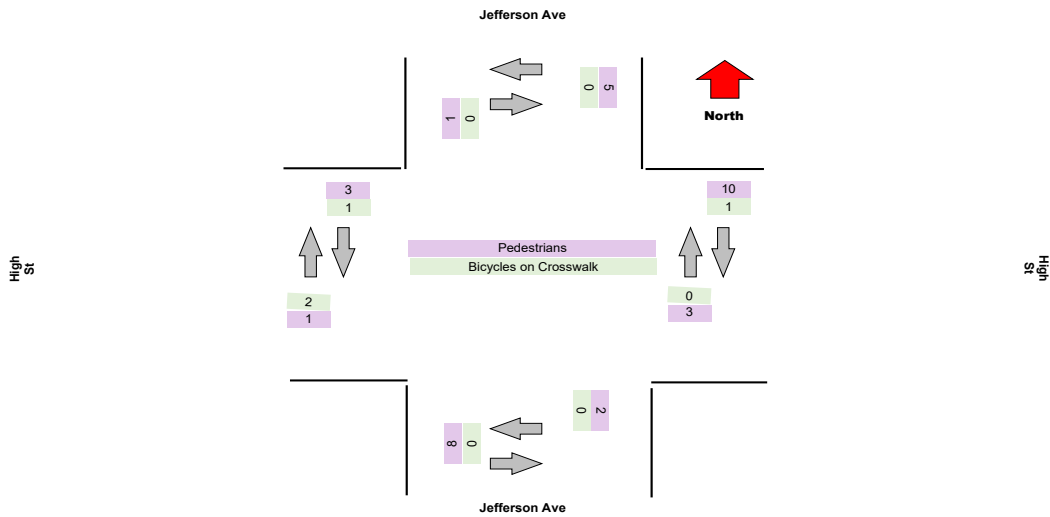
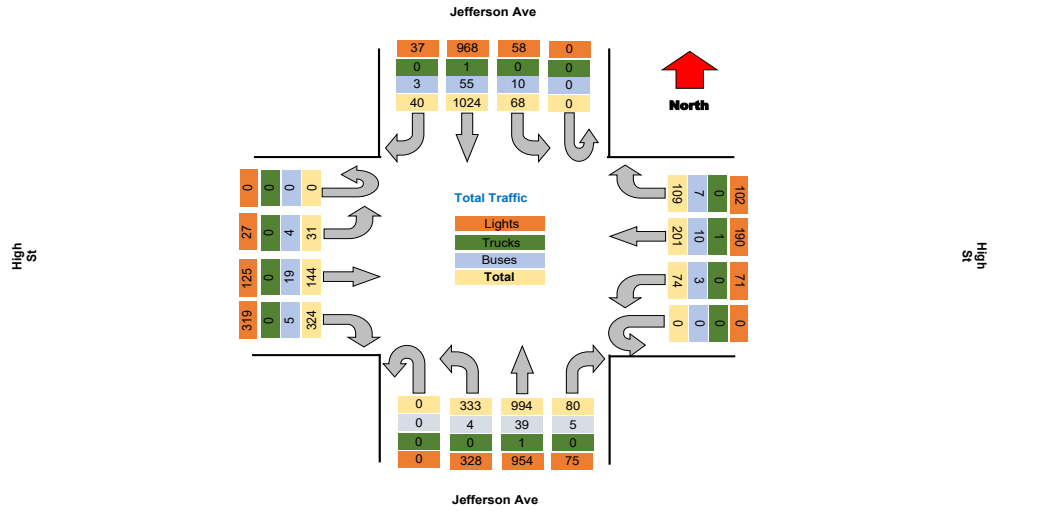

Turning Movement Peak Hour Data (AM)

7:30:00 AM

Leg Direction	Jefferson Ave							High St							Jefferson Ave							High St							Total
	Southbound			Westbound				Northbound			Eastbound				Northbound			Eastbound											
Start Time	Right	Thru	Left	U-Turn	App Total	Peds CW	Peds CCW	Right	Thru	Left	U-Turn	App Total	Peds CW	Peds CCW	Right	Thru	Left	U-Turn	App Total	Peds CW	Peds CCW	Right	Thru	Left	U-Turn	App Total	Peds CW	Peds CCW	
7:30:00 AM	2	45	6	0	53	0	0	6	17	3	0	26	0	0	5	67	36	0	108	0	0	19	8	0	0	27	0	0	214
7:45:00 AM	5	59	1	0	65	1	0	13	19	5	0	37	0	0	11	83	50	0	144	0	2	19	10	1	0	30	0	1	276
8:00:00 AM	4	79	6	0	89	0	0	9	13	4	0	26	1	0	7	69	26	0	103	0	1	18	10	1	0	29	0	0	247
8:15:00 AM	3	48	5	0	56	0	0	3	17	6	0	26	0	0	5	51	37	0	93	0	0	20	4	1	0	25	1	0	200
Grand Total	14	231	18	0	263	1	0	31	66	18	0	115	1	0	28	270	149	0	448	0	3	78	32	3	0	111	1	1	937
% Approach	5.3%	87.8%	6.8%	0.0%	0.0%	0.0%	0.0%	27.0%	57.4%	15.7%	0.0%	0.0%	0.0%	0.0%	6.3%	60.3%	33.3%	0.0%	0.0%	0.0%	0.0%	68.5%	26.8%	2.7%	0.0%	0.0%	0.0%	0.0%	0.0%
% Total	1.5%	24.7%	1.9%	0.0%	28.1%	0.0%	0.0%	3.3%	7.0%	1.9%	0.0%	12.3%	0.0%	0.0%	3.0%	28.8%	15.9%	0.0%	47.8%	0.0%	0.0%	8.1%	3.4%	0.3%	0.0%	11.8%	0.0%	0.0%	0.0%
PHF	0.700	0.731	0.750	0.000	0.739	0.000	0.000	0.596	0.868	0.750	0.000	0.777	0.000	0.000	0.636	0.813	0.745	0.000	0.778	0.000	0.000	0.950	0.800	0.750	0.000	0.925	0.000	0.000	0.849
Lights	13	208	14	0	235	0	0	29	64	16	0	109	0	0	25	255	148	0	428	0	0	74	26	1	0	101	0	0	873
% Lights	82.9%	90.0%	77.8%	0.0%	88.4%	0.0%	0.0%	83.5%	97.0%	88.9%	0.0%	94.8%	0.0%	0.0%	89.3%	94.4%	99.3%	0.0%	95.5%	0.0%	0.0%	97.4%	81.3%	33.3%	0.0%	91.0%	0.0%	0.0%	83.2%
Trucks	0	0	0	0	0	0	0	0	1	0	0	1	0	0	0	0	0	0	0	0	0	0	0	0	0	0	0	0	1
% Trucks	0.0%	0.0%	0.0%	0.0%	0.0%	0.0%	0.0%	0.0%	1.5%	0.0%	0.0%	0.9%	0.0%	0.0%	0.0%	0.0%	0.0%	0.0%	0.0%	0.0%	0.0%	0.0%	0.0%	0.0%	0.0%	0.0%	0.0%	0.1%	
Buses	1	23	4	0	28	0	0	2	1	2	0	5	0	0	3	15	1	0	19	0	0	2	6	2	0	10	0	0	62
% Buses	7.1%	10.0%	22.2%	0.0%	0.0%	0.0%	0.0%	6.5%	1.5%	11.1%	0.0%	0.0%	0.0%	0.0%	10.7%	5.8%	0.7%	0.0%	0.0%	0.0%	0.0%	2.6%	18.8%	66.7%	0.0%	0.0%	0.0%	0.0%	6.8%
Pedestrians	0	0	0	0	0	1	0	0	0	0	0	1	0	0	0	0	0	0	0	0	3	0	0	0	0	0	1	1	0
% Pedestrians	0.0%	0.0%	0.0%	0.0%	0.0%	100.0%	0.0%	0.0%	0.0%	0.0%	0.0%	0.0%	100.0%	0.0%	0.0%	0.0%	0.0%	0.0%	0.0%	0.0%	100.0%	0.0%	0.0%	0.0%	0.0%	0.0%	0.0%	100.0%	0.0%
Bicycles on Crosswalk	0	0	0	0	0	0	0	0	0	0	0	0	0	0	0	0	0	0	0	0	0	0	0	0	0	0	0	0	0
% Bicycles on Crosswalk	0.0%	0.0%	0.0%	0.0%	0.0%	0.0%	0.0%	0.0%	0.0%	0.0%	0.0%	0.0%	0.0%	0.0%	0.0%	0.0%	0.0%	0.0%	0.0%	0.0%	0.0%	0.0%	0.0%	0.0%	0.0%	0.0%	0.0%	0.0%	0.0%

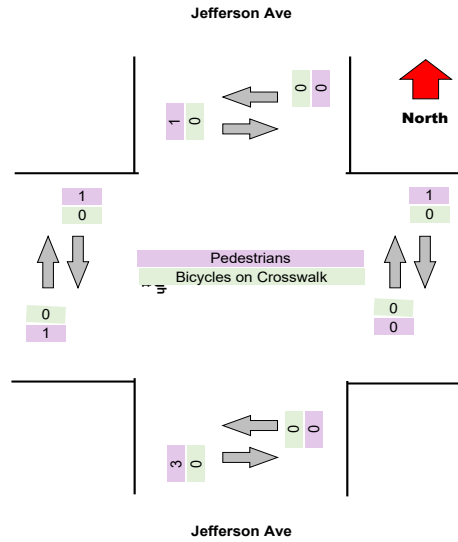
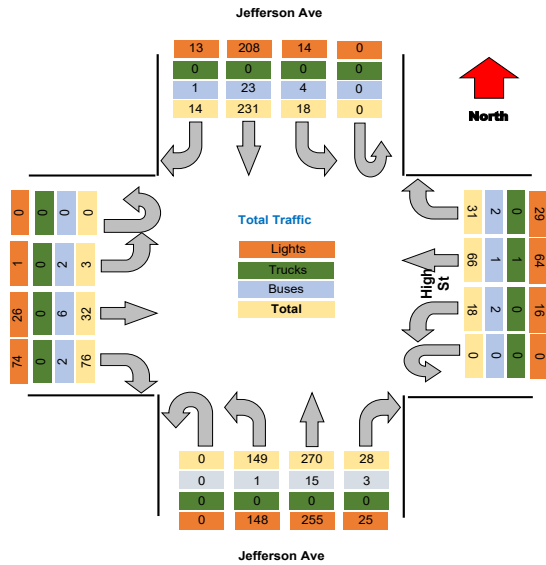

Turning Movement Peak Hour Data (PM)

4:15:00 PM

Leg Direction	Jefferson Ave										High St					Jefferson Ave										High St					Total
	Southbound					Westbound					Northbound					Eastbound															
	Right	Thru	Left	U-Turn	App Total	Peds CW	Peds CCW	Right	Thru	Left	U-Turn	App Total	Peds CW	Peds CCW	Right	Thru	Left	U-Turn	App Total	Peds CW	Peds CCW	Right	Thru	Left	U-Turn	App Total	Peds CW	Peds CCW			
4:15:00 PM	2	93	6	0	101	0	0	8	9	7	0	24	1	0	3	63	13	0	79	0	0	27	14	1	0	42	2	0	246		
4:30:00 PM	0	101	6	0	107	0	0	5	15	8	0	28	2	0	5	64	12	0	81	0	0	33	17	6	0	56	0	0	272		
4:45:00 PM	4	82	6	0	92	0	2	8	14	6	0	30	0	2	7	60	12	0	79	0	1	25	13	5	0	43	0	1	244		
5:00:00 PM	2	99	3	0	104	0	0	8	13	6	0	27	0	0	4	76	7	0	87	1	0	19	9	0	0	28	0	0	246		
Grand Total	9	375	21	0	404	0	2	29	51	29	0	109	3	2	19	293	44	0	326	1	1	104	53	12	0	169	2	1	1008		
% Approach	2.0%	92.8%	5.2%	0.0%	0.0%	0.0%	0.0%	26.6%	46.8%	26.6%	0.0%	0.0%	0.0%	0.0%	5.8%	80.7%	13.5%	0.0%	0.0%	0.0%	0.0%	61.5%	31.4%	7.1%	0.0%	0.0%	0.0%	0.0%	0.0%		
% Total	0.8%	37.2%	2.1%	0.0%	40.1%	0.0%	0.0%	2.9%	5.1%	2.9%	0.0%	10.8%	0.0%	0.0%	1.9%	26.1%	4.4%	0.0%	32.3%	0.0%	0.0%	10.3%	5.3%	1.2%	0.0%	16.8%	0.0%	0.0%	0.0%		
PHF	0.500	0.928	0.875	0.000	0.944	0.000	0.000	0.906	0.850	0.906	0.000	0.908	0.000	0.000	0.679	0.865	0.846	0.000	0.837	0.000	0.000	0.788	0.779	0.500	0.000	0.754	0.000	0.000	0.926		
Lights	7	364	19	0	390	0	0	27	46	28	0	101	0	0	19	254	42	0	315	0	0	103	45	12	0	160	0	0	966		
% Lights	87.5%	97.1%	90.5%	0.0%	96.5%	0.0%	0.0%	83.1%	90.2%	96.6%	0.0%	92.7%	0.0%	0.0%	100.0%	96.6%	95.5%	0.0%	96.6%	0.0%	0.0%	99.0%	84.9%	100.0%	0.0%	94.7%	0.0%	0.0%	95.8%		
Trucks	0	0	0	0	0	0	0	0	0	0	0	0	0	0	0	0	0	0	0	0	0	0	0	0	0	0	0	0	0		
% Trucks	0.0%	0.0%	0.0%	0.0%	0.0%	0.0%	0.0%	0.0%	0.0%	0.0%	0.0%	0.0%	0.0%	0.0%	0.0%	0.0%	0.0%	0.0%	0.0%	0.0%	0.0%	0.0%	0.0%	0.0%	0.0%	0.0%	0.0%	0.0%	0.0%		
Buses	1	11	2	0	14	0	0	2	5	1	0	8	0	0	0	9	1	0	10	0	0	1	8	0	0	9	0	0	41		
% Buses	12.5%	2.9%	9.5%	0.0%	0.0%	0.0%	0.0%	6.9%	9.8%	3.4%	0.0%	0.0%	0.0%	0.0%	0.0%	3.4%	2.3%	0.0%	0.0%	0.0%	0.0%	1.0%	15.1%	0.0%	0.0%	0.0%	0.0%	0.0%	4.1%		
Pedestrians	0	0	0	0	0	0	2	0	0	0	0	3	2	0	0	0	0	0	1	1	0	0	0	0	0	0	1	0	0		
% Pedestrians	0.0%	0.0%	0.0%	0.0%	0.0%	0.0%	100.0%	0.0%	0.0%	0.0%	0.0%	0.0%	100.0%	100.0%	0.0%	0.0%	0.0%	0.0%	0.0%	0.0%	100.0%	100.0%	0.0%	0.0%	0.0%	0.0%	0.0%	100.0%	0.0%		
Bicycles on Crosswalk	0	0	0	0	0	0	0	0	0	0	0	0	0	0	0	0	0	0	0	0	0	0	0	0	0	0	2	0	0		
% Bicycles on Crosswalk	0.0%	0.0%	0.0%	0.0%	0.0%	0.0%	0.0%	0.0%	0.0%	0.0%	0.0%	0.0%	0.0%	0.0%	0.0%	0.0%	0.0%	0.0%	0.0%	0.0%	0.0%	0.0%	0.0%	0.0%	0.0%	0.0%	100.0%	0.0%	0.0%		

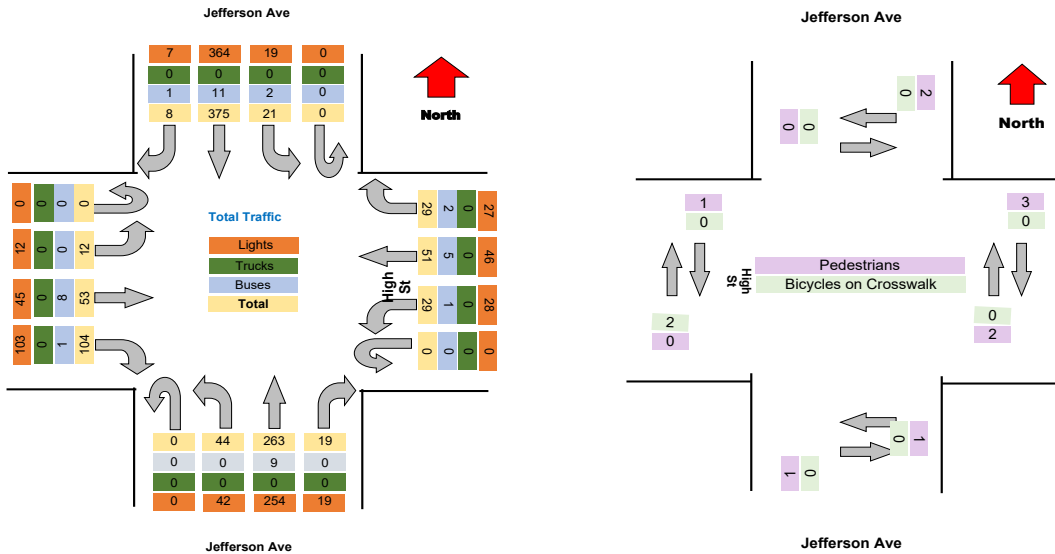

Project : VBH Malta NY
 Site : Site 4
 Location : 42.948550, -73.790036
 Survey Date : 2021-04-28, Wednesday

Turning Movement Data Plot

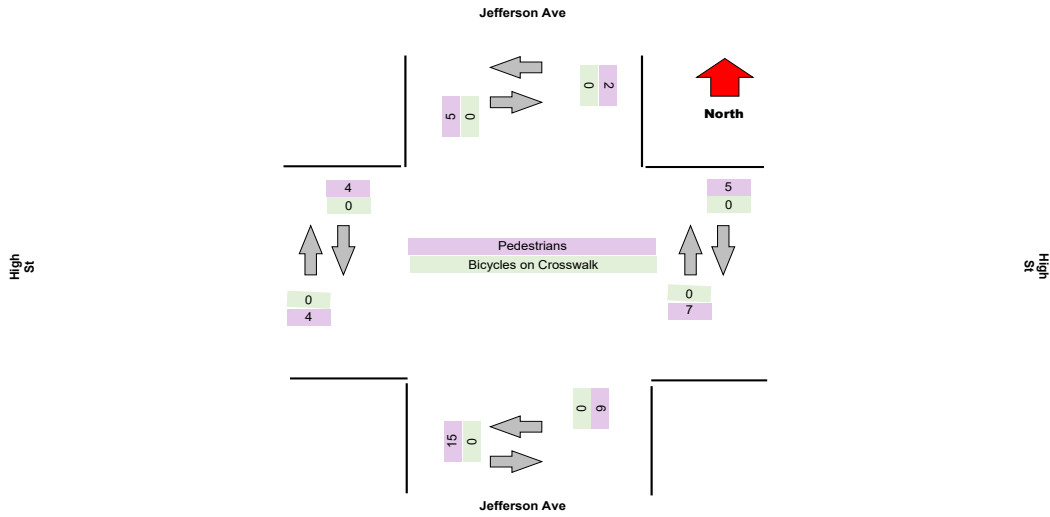
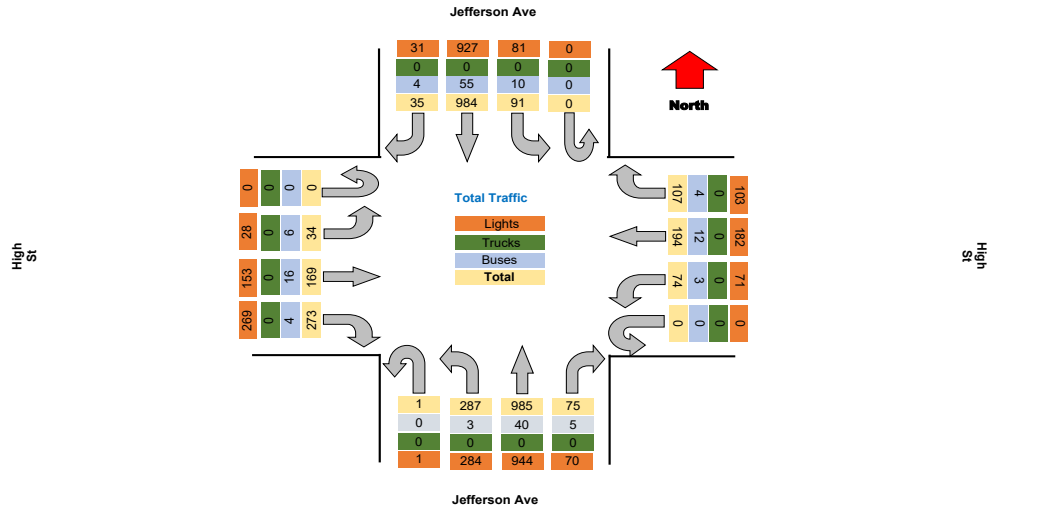

Project : VBH Malta NY
Site : Site 4
Location : 42.948550, -73.790036

TSTData.com

Survey Date : 2021-04-28, Wednesday

Turning Movement Peak Hour Data (AM)

7:30:00 AM

Leg Direction	Jefferson Ave						High St						Jefferson Ave						High St						Total				
	Southbound			Northbound			Westbound			Eastbound			Northbound			Eastbound													
Start Time	Right	Thru	Left	U-Turn	App Total	Peds CW	Peds CCW	Right	Thru	Left	U-Turn	App Total	Peds CW	Peds CCW	Right	Thru	Left	U-Turn	App Total	Peds CW	Peds CCW	Right	Thru	Left	U-Turn	App Total	Peds CW	Peds CCW	
7:30:00 AM	5	48	5	0	58	0	0	9	11	4	0	24	0	0	4	76	32	0	112	0	1	20	5	1	0	26	0	0	220
7:45:00 AM	4	49	4	0	57	0	1	15	23	9	0	48	0	1	5	95	37	0	138	0	3	16	11	3	0	30	1	2	273
8:00:00 AM	0	71	11	0	82	0	0	6	16	4	0	26	0	0	6	90	30	0	126	1	0	16	8	0	0	24	1	0	258
8:15:00 AM	2	49	5	0	56	0	0	5	7	7	0	19	0	0	7	51	25	0	83	0	1	9	6	5	0	20	0	0	181
Grand Total	11	217	25	0	253	0	1	35	57	24	0	117	0	1	22	312	127	0	439	1	5	61	30	9	0	100	2	2	932
% Approach	4.3%	85.8%	9.9%	0.0%	0.0%	0.0%	0.0%	29.9%	48.7%	20.5%	0.0%	0.0%	0.0%	0.0%	4.8%	67.5%	27.5%	0.0%	0.0%	0.0%	0.0%	61.0%	30.0%	9.0%	0.0%	0.0%	0.0%	0.0%	0.0%
% Total	1.2%	23.3%	2.7%	0.0%	27.1%	0.0%	0.0%	3.8%	6.1%	2.6%	0.0%	12.6%	0.0%	0.0%	2.4%	33.5%	13.6%	0.0%	49.6%	0.0%	0.0%	6.5%	3.2%	1.0%	0.0%	10.7%	0.0%	0.0%	0.0%
PHF	0.550	0.764	0.568	0.000	0.771	0.000	0.000	0.583	0.620	0.667	0.000	0.609	0.000	0.000	0.796	0.821	0.858	0.000	0.837	0.000	0.000	0.763	0.682	0.450	0.000	0.833	0.000	0.000	0.853
Lights	9	200	22	0	231	0	0	34	55	22	0	111	0	0	19	297	127	0	443	0	0	60	24	6	0	90	0	0	875
% Lights	81.8%	92.2%	88.0%	0.0%	91.3%	0.0%	0.0%	87.1%	96.5%	91.7%	0.0%	94.9%	0.0%	0.0%	86.4%	95.2%	100.0%	0.0%	95.9%	0.0%	0.0%	98.4%	80.0%	66.7%	0.0%	90.0%	0.0%	0.0%	93.9%
Trucks	0	0	0	0	0	0	0	0	0	0	0	0	0	0	0	0	0	0	0	0	0	0	0	0	0	0	0	0	0
% Trucks	0.0%	0.0%	0.0%	0.0%	0.0%	0.0%	0.0%	0.0%	0.0%	0.0%	0.0%	0.0%	0.0%	0.0%	0.0%	0.0%	0.0%	0.0%	0.0%	0.0%	0.0%	0.0%	0.0%	0.0%	0.0%	0.0%	0.0%	0.0%	0.0%
Buses	2	17	3	0	22	0	0	1	2	2	0	5	0	0	3	15	0	0	18	0	0	1	6	3	0	10	0	0	55
% Buses	18.2%	7.8%	12.0%	0.0%	0.0%	0.0%	0.0%	2.9%	3.5%	8.3%	0.0%	0.0%	0.0%	0.0%	13.6%	4.8%	0.0%	0.0%	0.0%	0.0%	0.0%	1.6%	20.0%	33.3%	0.0%	0.0%	0.0%	0.0%	5.9%
Pedestrians	0	0	0	0	0	0	1	0	0	0	0	0	1	5	0	0	0	0	0	1	5	0	0	0	0	0	2	2	0
% Pedestrians	0.0%	0.0%	0.0%	0.0%	0.0%	100.0%	100.0%	0.0%	0.0%	0.0%	0.0%	0.0%	100.0%	100.0%	0.0%	0.0%	0.0%	0.0%	0.0%	100.0%	100.0%	0.0%	0.0%	0.0%	0.0%	0.0%	100.0%	100.0%	0.0%
Bicycles on Crosswalk	0	0	0	0	0	0	0	0	0	0	0	0	0	0	0	0	0	0	0	0	0	0	0	0	0	0	0	0	0
% Bicycles on Crosswalk	0.0%	0.0%	0.0%	0.0%	0.0%	0.0%	0.0%	0.0%	0.0%	0.0%	0.0%	0.0%	0.0%	0.0%	0.0%	0.0%	0.0%	0.0%	0.0%	0.0%	0.0%	0.0%	0.0%	0.0%	0.0%	0.0%	0.0%	0.0%	0.0%

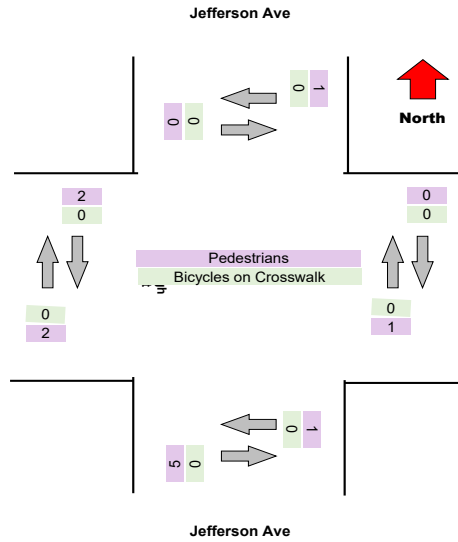
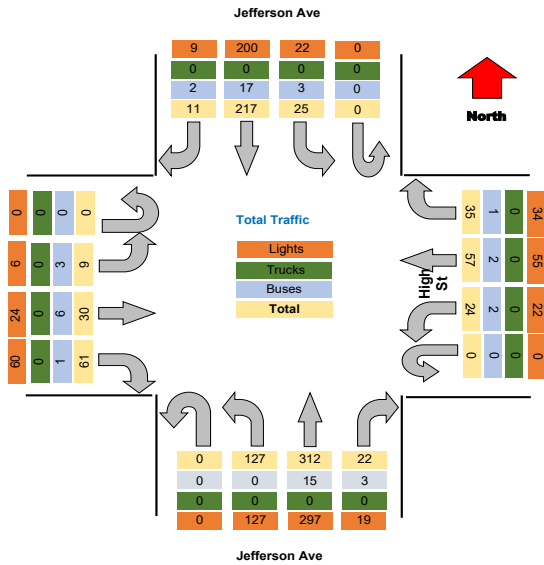

Turning Movement Peak Hour Data (PM)

4:15:00 PM

Leg Direction	Jefferson Ave								High St								Jefferson Ave								High St								Total
	Southbound				Westbound				Northbound				Eastbound				Southbound				Westbound				Northbound				Eastbound				
	Right	Thru	Left	U-Turn	App Total	Peds CW	Peds CCW		Right	Thru	Left	U-Turn	App Total	Peds CW	Peds CCW		Right	Thru	Left	U-Turn	App Total	Peds CW	Peds CCW		Right	Thru	Left	U-Turn	App Total	Peds CW	Peds CCW		
4:15:00 PM	1	86	10	0	97	0	0		4	11	10	0	25	0	1		5	67	10	0	82	0	0		24	10	2	0	36	0	0		240
4:30:00 PM	3	92	5	0	100	1	0		7	14	13	0	34	0	0		6	62	13	0	81	0	0		26	28	6	0	60	0	0		276
4:45:00 PM	4	73	4	0	81	0	0		9	12	3	0	24	2	0		5	66	9	0	80	2	1		22	9	3	0	34	0	0		219
5:00:00 PM	0	89	7	0	96	0	0		14	7	2	0	23	0	0		6	56	4	0	66	1	2		37	14	2	0	53	1	1		238
Grand Total	8	349	26	0	374	1	0		34	44	28	0	106	2	1		22	251	36	0	309	3	3		109	61	13	0	183	1	1		972
% Approach	2.1%	99.0%	7.0%	0.0%	0.0%	0.0%	0.0%		32.1%	41.5%	26.4%	0.0%	0.0%	0.0%	0.0%		7.1%	81.2%	11.7%	0.0%	0.0%	0.0%	0.0%		59.6%	33.3%	7.1%	0.0%	0.0%	0.0%	0.0%		
% Total	0.8%	35.0%	2.7%	0.0%	38.5%	0.0%	0.0%		3.5%	4.5%	2.9%	0.0%	10.9%	0.0%	0.0%		2.3%	25.8%	3.7%	0.0%	31.8%	0.0%	0.0%		11.2%	6.3%	1.3%	0.0%	18.8%	0.0%	0.0%		
PHF	0.500	0.924	0.650	0.000	0.935	0.000	0.000		0.607	0.786	0.538	0.000	0.779	0.000	0.000		0.917	0.937	0.692	0.000	0.842	0.000	0.000		0.738	0.545	0.542	0.000	0.763	0.000	0.000		0.884
Lights	7	329	23	0	359	0	0		33	39	27	0	99	0	0		22	242	35	0	299	0	0		109	55	12	0	176	0	0		933
% Lights	87.5%	96.8%	88.5%	0.0%	96.0%	0.0%	0.0%		87.1%	88.6%	96.4%	0.0%	93.4%	0.0%	0.0%		100.0%	96.4%	97.2%	0.0%	96.8%	0.0%	0.0%		100.0%	90.2%	92.3%	0.0%	96.2%	0.0%	0.0%		96.0%
Trucks	0	0	0	0	0	0	0		0	0	0	0	0	0	0		0	0	0	0	0	0	0		0	0	0	0	0	0	0		0
% Trucks	0.0%	0.0%	0.0%	0.0%	0.0%	0.0%	0.0%		0.0%	0.0%	0.0%	0.0%	0.0%	0.0%	0.0%		0.0%	0.0%	0.0%	0.0%	0.0%	0.0%	0.0%		0.0%	0.0%	0.0%	0.0%	0.0%	0.0%	0.0%		0.0%
Buses	1	11	3	0	15	0	0		1	5	1	0	7	0	0		0	8	1	0	9	0	0		0	6	1	0	7	0	0		38
% Buses	12.5%	3.2%	11.5%	0.0%	0.0%	0.0%	0.0%		2.9%	11.4%	3.6%	0.0%	0.0%	0.0%	0.0%		0.0%	3.2%	2.8%	0.0%	0.0%	0.0%	0.0%		0.0%	9.8%	7.7%	0.0%	0.0%	0.0%	0.0%		3.9%
Pedestrians	0	0	0	0	0	1	0		0	0	0	0	0	2	1		0	0	0	0	3	3	1		0	0	0	0	0	1	1		0
% Pedestrians	0.0%	0.0%	0.0%	0.0%	0.0%	100.0%	0.0%		0.0%	0.0%	0.0%	0.0%	0.0%	100.0%	100.0%		0.0%	0.0%	0.0%	0.0%	0.0%	100.0%	100.0%		0.0%	0.0%	0.0%	0.0%	0.0%	100.0%	100.0%		0.0%
Bicycles on Crosswalk	0	0	0	0	0	0	0		0	0	0	0	0	0	0		0	0	0	0	0	0	0		0	0	0	0	0	0	0		0
% Bicycles on Crosswalk	0.0%	0.0%	0.0%	0.0%	0.0%	0.0%	0.0%		0.0%	0.0%	0.0%	0.0%	0.0%	0.0%	0.0%		0.0%	0.0%	0.0%	0.0%	0.0%	0.0%	0.0%		0.0%	0.0%	0.0%	0.0%	0.0%	0.0%	0.0%		0.0%

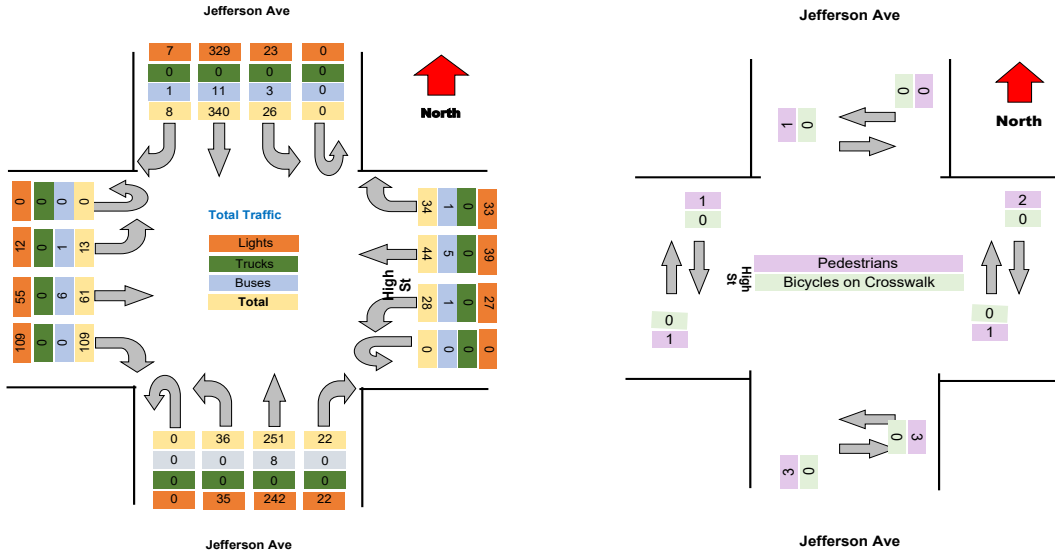

Project : VBH Malta NY
Site : Site 4
Location : 42.948550, -73.790036

TSTData.com

Survey Date : 2021-04-28, Wednesday

Project	LaBella
Project Code	LaBella
Site Name	39
Legs and Movements	All Processed Legs & Move
Bin Size	15 minutes
Survey Date	2021-11-02, Tuesday
Location	39
Latitude and Longitude	42.914728, -78.848108

	Start	End	PHF
Forced Peak AM	2021/11/02 07:30:00	2021/11/02 08:30:00	0.85
Forced Peak PM	2021/11/02 16:30:00	2021/11/02 17:30:00	0.89
AM Peak	2021/11/02 07:30:00	2021/11/02 08:30:00	0.85
PM Peak	2021/11/02 16:30:00	2021/11/02 17:30:00	0.89

Turning Movement Data

Leg Direction	Wohlers Ave Southbound							E Ferry St Westbound							Wohlers Ave Northbound							E Ferry St Eastbound							Total	
	Right	Thru	Left	U-Turn	App Total	Peds CV	Peds CCV	Right	Thru	Left	U-Turn	App Total	Peds CV	Peds CCV	Right	Thru	Left	U-Turn	App Total	Peds CV	Peds CCV	Right	Thru	Left	U-Turn	App Total	Peds CV	Peds CCV		
	Start Time																													
6:30:00 AM	0	0	0	0	0	0	0	6	62	2	0	70	0	0	4	3	2	0	9	0	0	1	33	1	0	35	0	0	114	
6:45:00 AM	0	0	0	0	0	0	0	3	58	0	0	61	0	0	2	2	1	0	5	1	0	1	23	1	0	25	0	0	91	
Hourly Total	0	0	0	0	0	0	0	9	120	2	0	131	0	0	6	5	3	0	14	1	0	2	56	2	0	60	0	0	205	
7:00:00 AM	0	0	0	0	0	0	0	5	47	0	0	52	0	0	2	3	0	0	5	1	1	3	34	3	0	40	0	0	97	
7:15:00 AM	0	0	0	0	0	0	0	7	61	0	0	68	0	0	2	5	1	0	8	0	0	2	27	3	0	32	0	0	108	
7:30:00 AM	0	0	0	0	0	0	0	7	69	0	0	76	0	1	6	5	0	0	12	0	0	2	33	2	0	37	0	0	125	
7:45:00 AM	0	1	0	0	1	0	1	9	120	1	0	131	0	0	6	3	3	0	12	0	0	0	44	1	0	45	0	0	189	
Hourly Total	0	1	0	0	1	0	1	28	297	1	0	327	0	1	16	16	4	0	37	1	1	7	138	9	0	154	0	0	519	
8:00:00 AM	0	0	0	0	0	7	5	8	95	3	0	111	0	0	9	5	1	0	15	0	0	1	39	4	0	44	0	1	170	
8:15:00 AM	0	0	0	0	0	0	0	12	82	1	0	95	0	0	8	3	0	0	11	0	0	4	42	7	0	53	2	2	159	
Hourly Total	0	0	0	0	0	7	5	20	177	4	0	206	0	0	17	8	1	0	26	0	0	5	81	11	0	97	2	3	329	
4:00:00 PM	0	0	0	0	0	2	3	22	93	1	0	116	1	0	9	17	5	0	31	1	0	3	94	13	0	110	3	6	257	
4:15:00 PM	0	0	0	0	0	1	0	16	116	4	0	136	0	1	8	9	1	0	18	0	1	6	72	10	0	88	2	6	242	
4:30:00 PM	0	0	0	0	0	1	1	19	110	2	0	131	0	1	12	9	4	0	25	0	1	4	76	10	0	90	6	6	246	
4:45:00 PM	0	0	0	0	0	1	0	23	95	3	0	121	0	0	11	11	1	0	23	0	1	4	77	8	0	89	3	2	233	
Hourly Total	0	0	0	0	0	5	4	80	414	10	0	504	1	1	40	46	11	0	97	1	3	17	319	41	0	377	13	20	978	
5:00:00 PM	0	0	0	0	0	1	2	17	96	2	0	115	0	1	7	10	2	0	19	0	0	6	83	22	0	111	3	1	245	
5:15:00 PM	0	0	0	0	0	1	4	24	132	6	0	162	0	1	9	12	3	0	24	0	2	6	79	12	0	97	3	5	283	
5:30:00 PM	0	0	0	0	0	0	1	21	106	3	0	130	2	0	11	11	6	0	28	0	0	1	61	13	0	75	5	4	233	
5:45:00 PM	0	0	0	0	0	2	1	18	114	1	0	133	0	1	17	5	3	0	25	1	1	5	58	10	0	73	7	7	231	
Hourly Total	0	0	0	0	0	4	8	80	448	12	0	540	2	3	44	38	14	0	96	1	3	18	281	57	0	356	18	17	992	
Grand Total	0	1	0	0	1	15	18	217	1456	29	0	1708	3	5	123	113	33	0	270	4	7	49	875	120	0	1044	33	40	3023	
% Approach	0.0%	100.0%	0.0%	0.0%	0.0%	0.0%	0.0%	12.7%	85.2%	1.7%	0.0%	0.0%	0.0%	45.6%	41.9%	12.2%	0.0%	0.0%	0.0%	0.0%	0.0%	0.0%	4.7%	83.8%	11.5%	0.0%	0.0%	0.0%	0.0%	0.0%
% Total	0.0%	0.0%	0.0%	0.0%	0.0%	0.0%	0.0%	7.2%	48.2%	1.0%	0.0%	86.5%	0.0%	0.0%	4.1%	3.7%	1.1%	0.0%	8.9%	0.0%	0.0%	1.6%	28.9%	4.0%	0.0%	34.5%	0.0%	0.0%	0.0%	
Lights	0	1	0	0	1	0	0	213	1427	27	0	1667	0	0	123	109	33	0	265	0	0	48	860	120	0	1028	0	0	2961	
% Lights	0.0%	100.0%	0.0%	0.0%	100.0%	0.0%	0.0%	58.2%	98.0%	93.1%	0.0%	97.6%	0.0%	0.0%	100.0%	96.5%	100.0%	0.0%	96.1%	0.0%	0.0%	98.0%	98.3%	100.0%	0.0%	98.5%	0.0%	0.0%	97.9%	
Trucks	0	0	0	0	0	0	0	0	2	0	0	2	0	0	0	0	0	0	0	0	0	0	0	0	0	0	0	0	2	
% Trucks	0.0%	0.0%	0.0%	0.0%	0.0%	0.0%	0.0%	0.0%	0.1%	0.0%	0.0%	0.1%	0.0%	0.0%	0.0%	0.0%	0.0%	0.0%	0.0%	0.0%	0.0%	0.0%	0.0%	0.0%	0.0%	0.0%	0.0%	0.0%	0.1%	
Buses	0	0	0	0	0	0	0	4	26	2	0	32	0	0	0	4	0	0	4	0	0	1	14	0	0	15	0	0	51	
% Buses	0.0%	0.0%	0.0%	0.0%	0.0%	0.0%	0.0%	0.0%	1.8%	6.9%	0.0%	0.0%	0.0%	0.0%	0.0%	3.5%	0.0%	0.0%	0.0%	0.0%	0.0%	2.0%	1.6%	0.0%	0.0%	0.0%	0.0%	0.0%	1.7%	
Pedestrians	0	0	0	0	0	14	17	0	0	0	0	0	3	5	0	0	0	0	0	4	7	0	0	0	0	0	33	36	0	
% Pedestrians	0.0%	0.0%	0.0%	0.0%	0.0%	87.5%	84.4%	0.0%	0.0%	0.0%	0.0%	0.0%	100.0%	100.0%	0.0%	0.0%	0.0%	0.0%	0.0%	100.0%	100.0%	0.0%	0.0%	0.0%	0.0%	0.0%	100.0%	80.0%	0.0%	
Bicycles on Crosswalk	0	0	0	0	0	2	1	0	0	0	0	0	0	0	0	0	0	0	0	0	0	0	0	0	0	0	0	4	0	
% Bicycles on Crosswalk	0.0%	0.0%	0.0%	0.0%	0.0%	12.5%	5.6%	0.0%	0.0%	0.0%	0.0%	0.0%	0.0%	0.0%	0.0%	0.0%	0.0%	0.0%	0.0%	0.0%	0.0%	0.0%	0.0%	0.0%	0.0%	0.0%	0.0%	10.0%	0.0%	

Project : VBH Malta NY
 Site : Site 4
 Location : 42.948550, -73.790036
 Survey Date : 2021-04-28, Wednesday

Turning Movement Data Plot

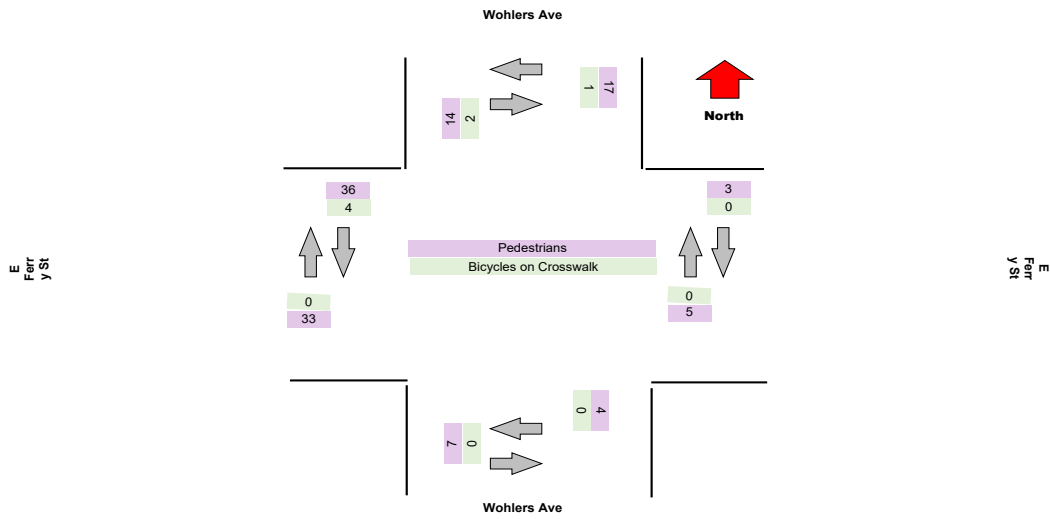
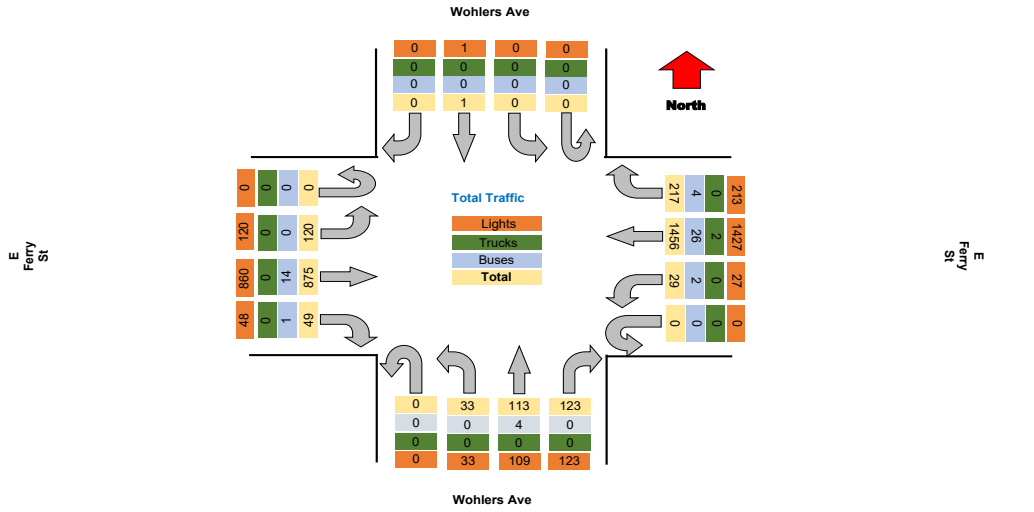

Project : VBH Malta NY
Site : Site 4
Location : 42.948550, -73.790036
Survey Date : 2021-04-28, Wednesday

TSTData.com

Turning Movement Peak Hour Data (AM)

7:30:00 AM

Leg Direction	Wohlers Ave										E Ferry St										Wohlers Ave										E Ferry St										Total
	Southbound					Westbound					Northbound					Eastbound					Northbound					Eastbound															
	Right	Thru	Left	U-Turn	App Total	Right	Thru	Left	U-Turn	App Total	Right	Thru	Left	U-Turn	App Total	Right	Thru	Left	U-Turn	App Total	Right	Thru	Left	U-Turn	App Total	Right	Thru	Left	U-Turn	App Total											
7:30:00 AM	0	0	0	0	0	7	69	0	0	76	0	0	1	0	1	6	5	0	0	12	0	0	0	0	0	2	33	2	0	37											
7:45:00 AM	0	1	0	0	1	9	120	1	0	131	0	0	0	0	0	6	3	3	0	12	0	0	0	0	0	0	44	1	0	45											
8:00:00 AM	0	0	0	0	0	8	95	3	0	111	0	0	0	0	0	9	5	1	0	15	0	0	0	0	0	1	39	4	0	44											
8:15:00 AM	0	0	0	0	0	12	62	1	0	75	0	0	0	0	0	8	3	0	0	11	0	0	0	0	0	4	42	7	0	53											
Grand Total	0	1	0	0	1	36	356	5	0	413	0	0	1	0	1	29	15	4	0	48	0	0	0	0	0	7	155	14	0	176											
% Approach	0.0%	100.0%	0.0%	0.0%	0.0%	8.7%	88.6%	1.2%	0.0%	0.0%	58.0%	32.0%	8.0%	0.0%	0.0%	3.9%	85.3%	7.8%	0.0%	0.0%	0.0%	0.0%	0.0%	0.0%	0.0%	0.0%	0.0%	0.0%	0.0%	0.0%											
% Total	0.0%	0.2%	0.0%	0.0%	0.2%	5.6%	56.9%	0.8%	0.0%	64.2%	0.0%	0.0%	0.0%	0.0%	0.0%	4.5%	2.5%	0.6%	0.0%	7.6%	0.0%	0.0%	0.0%	0.0%	0.0%	1.1%	24.6%	2.2%	0.0%	27.8%											
PHF	0.000	0.250	0.000	0.000	0.250	0.750	0.783	0.417	0.000	0.788	0.000	0.000	0.000	0.000	0.000	0.806	0.800	0.333	0.000	0.833	0.000	0.000	0.000	0.000	0.000	0.438	0.888	0.500	0.000	0.844											
Lights	0	1	0	0	1	33	358	5	0	396	0	0	0	0	0	29	15	4	0	48	0	0	0	0	0	7	155	14	0	176											
% Lights	0.0%	100.0%	0.0%	0.0%	100.0%	81.7%	97.8%	100.0%	0.0%	95.9%	0.0%	0.0%	0.0%	0.0%	0.0%	100.0%	93.8%	100.0%	0.0%	96.0%	0.0%	0.0%	0.0%	0.0%	0.0%	100.0%	98.1%	100.0%	0.0%	98.3%											
Trucks	0	0	0	0	0	0	1	0	0	1	0	0	0	0	0	0	0	0	0	0	0	0	0	0	0	0	0	0	0	0											
% Trucks	0.0%	0.0%	0.0%	0.0%	0.0%	0.0%	0.3%	0.0%	0.0%	0.2%	0.0%	0.0%	0.0%	0.0%	0.0%	0.0%	0.0%	0.0%	0.0%	0.0%	0.0%	0.0%	0.0%	0.0%	0.0%	0.0%	0.0%	0.0%	0.0%	0.0%											
Buses	0	0	0	0	0	3	6	0	0	9	0	0	0	0	0	0	1	0	0	1	0	0	0	0	0	0	3	0	0	3											
% Buses	0.0%	0.0%	0.0%	0.0%	0.0%	8.3%	1.6%	0.0%	0.0%	0.0%	0.0%	0.0%	0.0%	0.0%	0.0%	0.0%	6.3%	0.0%	0.0%	0.0%	0.0%	1.9%	0.0%	0.0%	0.0%	0.0%	1.9%	0.0%	0.0%	0.0%											
Pedestrians	0	0	0	0	7	0	0	0	0	0	0	1	0	0	1	0	0	0	0	0	0	0	0	0	0	0	0	0	0	0											
% Pedestrians	0.0%	0.0%	0.0%	0.0%	100.0%	0.0%	0.0%	0.0%	0.0%	0.0%	0.0%	100.0%	0.0%	0.0%	100.0%	0.0%	0.0%	0.0%	0.0%	0.0%	0.0%	0.0%	0.0%	0.0%	0.0%	0.0%	0.0%	0.0%	0.0%	0.0%											
Bicycles on Crosswalk	0	0	0	0	0	0	0	0	0	0	0	0	0	0	0	0	0	0	0	0	0	0	0	0	0	0	0	0	0	0											
% Bicycles on Crosswalk	0.0%	0.0%	0.0%	0.0%	0.0%	0.0%	0.0%	0.0%	0.0%	0.0%	0.0%	0.0%	0.0%	0.0%	0.0%	0.0%	0.0%	0.0%	0.0%	0.0%	0.0%	0.0%	0.0%	0.0%	0.0%	0.0%	0.0%	0.0%	0.0%	0.0%											

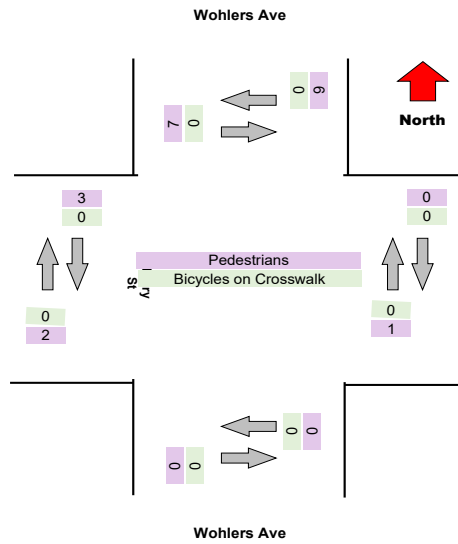
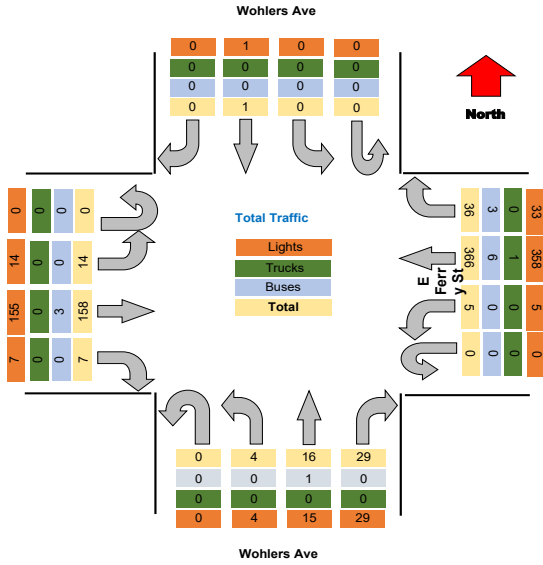

Turning Movement Peak Hour Data (PM)

4:30:00 PM

Leg Direction	Wohlers Ave										E Ferry St										Wohlers Ave										E Ferry St										Total
	Southbound					Westbound					Northbound					Eastbound																									
	Right	Thru	Left	U-Turn	App Total	Right	Thru	Left	U-Turn	App Total	Right	Thru	Left	U-Turn	App Total	Right	Thru	Left	U-Turn	App Total																					
4:30:00 PM	0	0	0	0	0	19	110	2	0	131	12	9	4	0	25	4	76	10	0	90	6	6	0	0	12	246															
4:45:00 PM	0	0	0	0	0	23	95	3	0	121	11	11	1	0	23	4	77	8	0	89	2	2	0	0	4	233															
5:00:00 PM	0	0	0	0	0	17	96	2	0	115	7	10	2	0	19	0	63	22	0	111	3	1	0	0	7	245															
5:15:00 PM	0	0	0	0	0	24	132	6	0	162	9	12	3	0	24	6	79	12	0	97	3	5	0	0	13	233															
Grand Total	0	0	0	0	0	83	433	13	0	529	39	42	10	0	91	20	315	52	0	387	14	14	0	0	28	1007															
% Approach	#DIV/0!	#DIV/0!	#DIV/0!	#DIV/0!	0.0%	15.7%	81.9%	2.5%	0.0%	0.0%	42.9%	46.2%	11.0%	0.0%	0.0%	5.2%	81.4%	13.4%	0.0%	0.0%	0.0%	0.0%	0.0%	0.0%	0.0%																
% Total	0.0%	0.0%	0.0%	0.0%	0.0%	8.2%	43.0%	1.3%	0.0%	52.5%	3.9%	4.2%	1.0%	0.0%	8.0%	2.0%	31.3%	5.2%	0.0%	38.4%	0.0%	0.0%	0.0%	0.0%	0.0%																
PHF	0.000	0.000	0.000	0.000	0.000	0.865	0.820	0.542	0.000	0.816	0.813	0.875	0.625	0.000	0.910	0.833	0.849	0.591	0.000	0.872	0.000	0.000	0.000	0.000	0.000	0.890															
Lights	0	0	0	0	0	82	427	13	0	522	39	42	10	0	91	20	311	52	0	383	0	0	0	0	0	996															
% Lights	0.0%	0.0%	0.0%	0.0%	0.0%	98.8%	98.6%	100.0%	0.0%	98.7%	100.0%	100.0%	100.0%	0.0%	100.0%	100.0%	98.7%	100.0%	0.0%	99.0%	0.0%	0.0%	0.0%	0.0%	0.0%	98.9%															
Trucks	0	0	0	0	0	0	1	0	0	1	0	0	0	0	0	0	0	0	0	0	0	0	0	0	0	1															
% Trucks	0.0%	0.0%	0.0%	0.0%	0.0%	0.0%	0.2%	0.0%	0.0%	0.2%	0.0%	0.0%	0.0%	0.0%	0.0%	0.0%	0.0%	0.0%	0.0%	0.0%	0.0%	0.0%	0.0%	0.0%	0.0%	0.1%															
Buses	0	0	0	0	0	1	5	0	0	6	0	0	0	0	0	0	4	0	0	4	0	0	0	0	0	10															
% Buses	0.0%	0.0%	0.0%	0.0%	0.0%	1.2%	1.2%	0.0%	0.0%	0.0%	0.0%	0.0%	0.0%	0.0%	0.0%	0.0%	1.3%	0.0%	0.0%	0.0%	0.0%	0.0%	0.0%	0.0%	0.0%	1.0%															
Pedestrians	0	0	0	0	3	0	0	0	0	0	0	0	0	0	4	0	0	0	0	0	14	13	0	0	0	27															
% Pedestrians	0.0%	0.0%	0.0%	0.0%	75.0%	0.0%	0.0%	0.0%	0.0%	0.0%	0.0%	0.0%	0.0%	0.0%	0.0%	0.0%	0.0%	0.0%	0.0%	0.0%	100.0%	92.9%	0.0%	0.0%	0.0%	0.9%															
Bicycles on Crosswalk	0	0	0	0	1	0	0	0	0	0	0	0	0	0	0	0	0	0	0	0	0	0	0	0	1	1															
% Bicycles on Crosswalk	0.0%	0.0%	0.0%	0.0%	0.0%	0.0%	0.0%	0.0%	0.0%	0.0%	0.0%	0.0%	0.0%	0.0%	0.0%	0.0%	0.0%	0.0%	0.0%	0.0%	0.0%	0.0%	0.0%	0.0%	7.1%	0.0%															

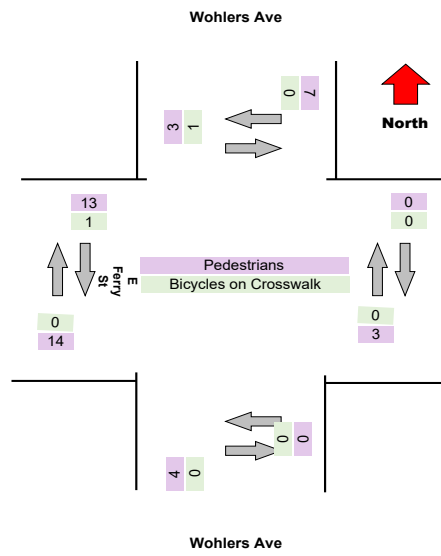
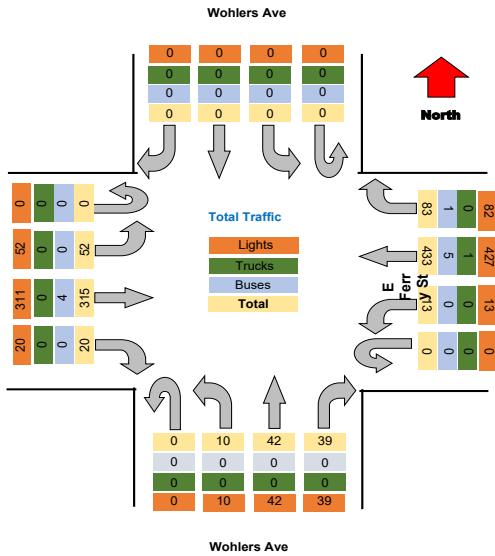

Project : VBH Malta NY
 Site : Site 4
 Location : 42.948550, -73.790036

TSTData.com

Survey Date : 2021-04-28, Wednesday

Project	LaBella
Project Code	LaBella
Site Name	39
Legs and Movements	All Processed Legs & Move
Bin Size	15 minutes
Survey Date	2021-11-03, Wednesday
Location	39
Latitude and Longitude	42.914728, -78.848108

	Start	End	PHF
Forced Peak AM	2021/11/03 07:30:00	2021/11/03 08:30:00	0.85
Forced Peak PM	2021/11/03 16:30:00	2021/11/03 17:30:00	0.94
AM Peak	2021/11/03 07:30:00	2021/11/03 08:30:00	0.85
PM Peak	2021/11/03 16:30:00	2021/11/03 17:30:00	0.94

Turning Movement Data

Leg Direction	Wohlers Ave Southbound							E Ferry St Westbound							Wohlers Ave Northbound							E Ferry St Eastbound							Total	
	Right	Thru	Left	U-Turn	App Total	Peds CV	Peds CCV	Right	Thru	Left	U-Turn	App Total	Peds CV	Peds CCV	Right	Thru	Left	U-Turn	App Total	Peds CV	Peds CCV	Right	Thru	Left	U-Turn	App Total	Peds CV	Peds CCV		
	Start Time																													
6:30:00 AM	0	0	0	0	0	0	0	5	50	0	0	55	1	0	2	2	0	0	5	0	0	3	33	2	0	38	0	0	96	
6:45:00 AM	0	0	0	0	0	0	0	7	55	4	0	67	0	0	2	4	1	0	8	1	0	2	21	0	0	23	0	0	98	
Hourly Total	0	0	0	0	0	0	0	12	105	4	0	122	1	0	4	6	1	0	13	1	0	5	54	2	0	61	0	0	196	
7:00:00 AM	0	0	0	0	1	0	0	8	59	1	0	68	2	0	3	3	1	0	9	1	0	5	35	1	0	41	1	0	118	
7:15:00 AM	0	0	0	0	0	1	0	9	77	4	0	91	0	0	3	8	3	0	14	0	1	0	37	3	0	40	0	3	145	
7:30:00 AM	0	0	0	0	0	0	0	5	122	2	0	129	0	1	10	12	3	0	26	0	0	0	61	6	0	67	1	1	222	
7:45:00 AM	0	0	0	0	0	0	1	13	147	2	0	163	0	0	7	6	2	0	15	1	0	1	79	5	0	85	2	1	263	
Hourly Total	0	0	0	0	0	2	2	35	405	9	0	451	2	1	23	29	9	0	64	2	1	6	212	15	0	233	4	5	748	
8:00:00 AM	0	0	0	0	0	3	0	11	120	9	0	140	2	0	9	4	4	0	19	1	0	1	57	1	0	59	3	4	218	
8:15:00 AM	0	0	0	0	0	0	1	20	84	10	0	115	0	0	9	7	2	0	18	0	0	2	49	4	0	55	2	1	188	
Hourly Total	0	0	0	0	0	3	1	31	204	19	0	255	2	0	18	11	6	0	37	1	0	3	106	5	0	114	5	5	406	
4:00:00 PM	0	0	1	0	1	3	5	25	103	6	0	134	0	0	18	11	0	0	29	0	1	7	99	8	0	114	4	5	278	
4:15:00 PM	0	0	0	0	0	1	4	23	112	4	0	139	1	0	10	16	8	0	34	0	2	5	87	14	0	106	3	3	279	
4:30:00 PM	0	0	0	0	0	3	1	23	107	7	0	137	0	0	10	7	2	0	19	0	0	3	89	14	0	106	3	2	262	
4:45:00 PM	0	0	0	0	0	2	0	25	104	3	0	132	0	0	13	13	0	0	26	1	0	0	82	7	0	89	5	0	247	
Hourly Total	0	0	1	0	1	9	12	96	426	20	0	542	1	0	51	47	10	0	108	1	3	15	357	43	0	415	15	10	1066	
5:00:00 PM	0	0	0	0	0	0	0	24	101	4	0	129	1	1	4	11	2	0	17	1	0	5	76	11	0	91	0	2	237	
5:15:00 PM	0	0	0	0	0	4	3	24	123	1	0	148	0	0	8	7	2	0	17	0	1	4	86	14	0	104	4	3	269	
5:30:00 PM	0	0	0	0	0	1	1	17	109	1	0	127	1	0	11	14	2	0	27	2	2	3	73	10	0	86	5	2	240	
5:45:00 PM	0	0	0	0	0	1	1	22	117	5	0	144	0	0	13	18	2	0	33	2	0	10	72	11	0	93	1	3	270	
Hourly Total	0	0	0	0	0	6	5	87	450	11	0	548	2	1	36	50	8	0	94	5	3	22	306	46	0	374	10	10	1016	
Grand Total	0	0	1	0	1	20	21	261	1590	63	0	1918	8	3	132	143	34	0	316	10	7	51	1035	111	0	1197	34	20	3432	
% Approach	0.0%	0.0%	100.0%	0.0%	0.0%	0.0%	0.0%	13.6%	82.9%	3.3%	0.0%	0.0%	0.0%	41.8%	45.3%	10.8%	0.0%	0.0%	0.0%	0.0%	0.0%	0.0%	4.3%	86.5%	9.3%	0.0%	0.0%	0.0%	0.0%	0.0%
% Total	0.0%	0.0%	0.0%	0.0%	0.0%	0.0%	0.0%	7.6%	46.3%	1.8%	0.0%	55.9%	0.0%	0.0%	3.8%	4.2%	1.0%	0.0%	9.2%	0.0%	0.0%	1.5%	30.2%	3.2%	0.0%	34.9%	0.0%	0.0%	0.0%	
Lights	0	0	1	0	1	0	0	243	1542	55	0	1840	0	0	127	124	25	0	276	0	0	44	988	86	0	1130	0	0	3247	
% Lights	0.0%	0.0%	100.0%	0.0%	100.0%	0.0%	0.0%	53.1%	87.0%	87.3%	0.0%	85.9%	0.0%	0.0%	66.2%	86.7%	73.5%	0.0%	87.3%	0.0%	0.0%	86.3%	95.5%	86.3%	0.0%	94.4%	0.0%	0.0%	94.6%	
Trucks	0	0	0	0	0	0	0	0	0	0	0	0	0	0	0	0	0	0	0	0	0	0	0	0	0	0	0	0	0	
% Trucks	0.0%	0.0%	0.0%	0.0%	0.0%	0.0%	0.0%	0.0%	0.0%	0.0%	0.0%	0.0%	0.0%	0.0%	0.0%	0.0%	0.0%	0.0%	0.0%	0.0%	0.0%	0.0%	0.0%	0.0%	0.0%	0.0%	0.0%			
Buses	0	0	0	0	0	0	0	18	48	8	0	74	0	0	5	19	9	0	33	0	0	7	46	13	0	66	0	0	173	
% Buses	0.0%	0.0%	0.0%	0.0%	0.0%	0.0%	0.0%	0.0%	3.0%	12.7%	0.0%	0.0%	0.0%	0.0%	3.8%	13.3%	26.5%	0.0%	0.0%	0.0%	0.0%	13.7%	4.4%	11.7%	0.0%	0.0%	0.0%	0.0%	5.0%	
Pedestrians	0	0	0	0	0	20	20	0	0	0	0	0	8	3	0	0	0	0	0	10	6	0	0	0	0	0	32	28	0	
% Pedestrians	0.0%	0.0%	0.0%	0.0%	0.0%	100.0%	85.2%	0.0%	0.0%	0.0%	0.0%	0.0%	100.0%	100.0%	0.0%	0.0%	0.0%	0.0%	0.0%	100.0%	85.7%	0.0%	0.0%	0.0%	0.0%	0.0%	84.1%	83.3%	0.0%	
Bicycles on Crosswalk	0	0	0	0	0	0	1	0	0	0	0	0	0	0	0	0	0	0	0	0	1	0	0	0	0	0	2	2	0	
% Bicycles on Crosswalk	0.0%	0.0%	0.0%	0.0%	0.0%	0.0%	4.8%	0.0%	0.0%	0.0%	0.0%	0.0%	0.0%	0.0%	0.0%	0.0%	0.0%	0.0%	0.0%	0.0%	14.3%	0.0%	0.0%	0.0%	0.0%	0.0%	0.0%	5.9%	6.7%	0.0%

Project : VBH Malta NY
 Site : Site 4
 Location : 42.948550, -73.790036
 Survey Date : 2021-04-28, Wednesday

Turning Movement Data Plot

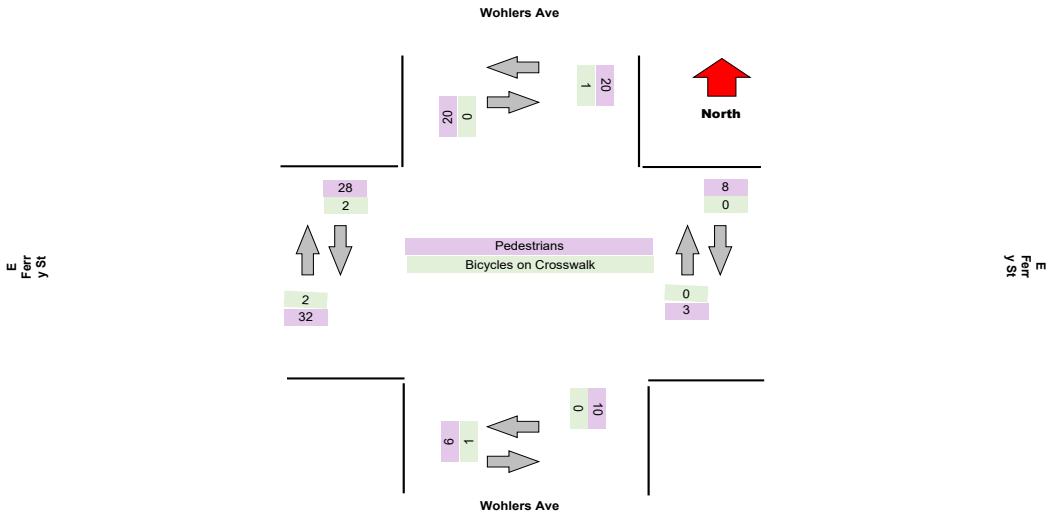
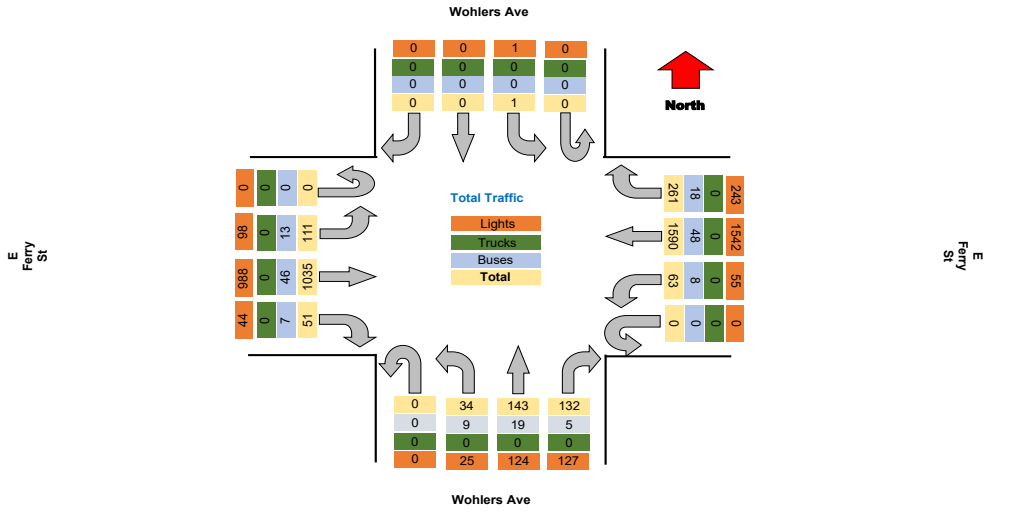

Project : VBH Malta NY
Site : Site 4
Location : 42.948550, -73.790036

TSTData.com

Survey Date : 2021-04-28, Wednesday

Turning Movement Peak Hour Data (AM)

7:30:00 AM

Leg Direction	Wohlers Ave								E Ferry St								Wohlers Ave								E Ferry St								Total
	Southbound				Westbound				Northbound				Eastbound				Northbound				Eastbound												
Start Time	Right	Thru	Left	U-Turn	App Total	Peds CW	Peds CCW		Right	Thru	Left	U-Turn	App Total	Peds CW	Peds CCW		Right	Thru	Left	U-Turn	App Total	Peds CW	Peds CCW		Right	Thru	Left	U-Turn	App Total	Peds CW	Peds CCW		
7:30:00 AM	0	0	0	0	0	0	0		5	122	2	0	129	0	1		10	12	3	0	26	0	0		0	61	6	0	67	1	1		222
7:45:00 AM	0	0	0	0	0	0	1		13	147	2	0	163	0	0		7	6	2	0	15	1	0		1	79	5	0	85	2	1		263
8:00:00 AM	0	0	0	0	0	3	0		11	120	9	0	140	2	0		9	4	4	0	19	1	0		1	57	1	0	59	3	4		218
8:15:00 AM	0	0	0	0	0	0	1		20	84	10	0	115	0	0		9	7	2	0	18	0	0		2	49	4	0	55	2	1		168
Grand Total	0	0	0	0	0	3	1		49	473	23	0	547	2	1		35	29	11	0	75	2	0		4	246	16	0	256	3	7		891
% Approach	#DIV/0!	#DIV/0!	#DIV/0!	#DIV/0!	0.0%	0.0%	0.0%		9.0%	86.5%	4.2%	0.0%	0.0%	0.0%	0.0%		44.0%	37.2%	14.1%	0.0%	0.0%	0.0%	0.0%		1.5%	92.5%	6.0%	0.0%	0.0%	0.0%	0.0%		
% Total	0.0%	0.0%	0.0%	0.0%	0.0%	0.0%	0.0%		5.5%	53.1%	2.6%	0.0%	61.4%	0.0%	0.0%		3.9%	3.3%	1.2%	0.0%	8.8%	0.0%	0.0%		0.4%	27.6%	1.8%	0.0%	29.9%	0.0%	0.0%		
PHF	0.000	0.000	0.000	0.000	0.000	0.000	0.000		0.613	0.804	0.575	0.000	0.839	0.000	0.000		0.875	0.604	0.688	0.000	0.750	0.000	0.000		0.500	0.778	0.667	0.000	0.782	0.000	0.000		0.847
Lights	0	0	0	0	0	0	0		43	456	23	0	522	0	0		33	24	6	0	63	0	0		4	225	11	0	240	0	0		825
% Lights	0.0%	0.0%	0.0%	0.0%	0.0%	0.0%	0.0%		87.8%	96.4%	100.0%	0.0%	95.4%	0.0%	0.0%		84.3%	82.8%	54.5%	0.0%	80.8%	0.0%	0.0%		100.0%	91.5%	68.8%	0.0%	90.2%	0.0%	0.0%		92.6%
Trucks	0	0	0	0	0	0	0		0	0	0	0	0	0	0		0	0	0	0	0	0	0		0	0	0	0	0	0	0		0
% Trucks	0.0%	0.0%	0.0%	0.0%	0.0%	0.0%	0.0%		0.0%	0.0%	0.0%	0.0%	0.0%	0.0%	0.0%		0.0%	0.0%	0.0%	0.0%	0.0%	0.0%	0.0%		0.0%	0.0%	0.0%	0.0%	0.0%	0.0%	0.0%		0.0%
Buses	0	0	0	0	0	0	0		6	17	0	0	23	0	0		2	5	5	0	12	0	0		0	21	5	0	26	0	0		61
% Buses	0.0%	0.0%	0.0%	0.0%	0.0%	0.0%	0.0%		12.2%	3.6%	0.0%	0.0%	0.0%	0.0%	0.0%		5.7%	17.2%	45.5%	0.0%	0.0%	0.0%	0.0%		0.0%	8.5%	31.3%	0.0%	0.0%	0.0%	0.0%		6.8%
Pedestrians	0	0	0	0	3	2	0		0	0	0	0	2	1	0		0	0	0	0	2	0	0		0	0	0	0	0	8	7		7
% Pedestrians	0.0%	0.0%	0.0%	0.0%	0.0%	100.0%	100.0%		0.0%	0.0%	0.0%	0.0%	0.0%	100.0%	100.0%		0.0%	0.0%	0.0%	0.0%	0.0%	100.0%	100.0%		0.0%	0.0%	0.0%	0.0%	0.0%	100.0%	100.0%		0.0%
Bicycles on Crosswalk	0	0	0	0	0	0	0		0	0	0	0	0	0	0		0	0	0	0	0	0	0		0	0	0	0	0	0	0		0
% Bicycles on Crosswalk	0.0%	0.0%	0.0%	0.0%	0.0%	0.0%	0.0%		0.0%	0.0%	0.0%	0.0%	0.0%	0.0%	0.0%		0.0%	0.0%	0.0%	0.0%	0.0%	0.0%	0.0%		0.0%	0.0%	0.0%	0.0%	0.0%	0.0%	0.0%		0.0%

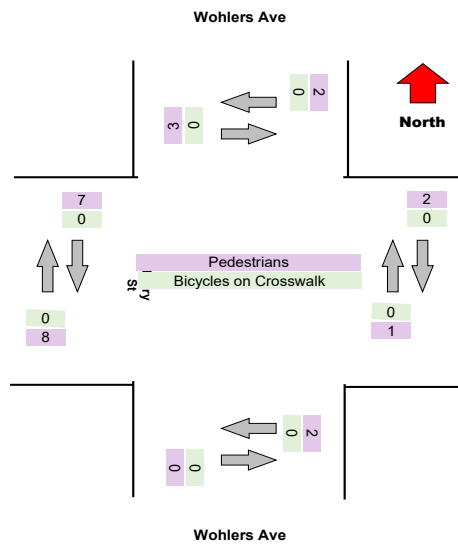
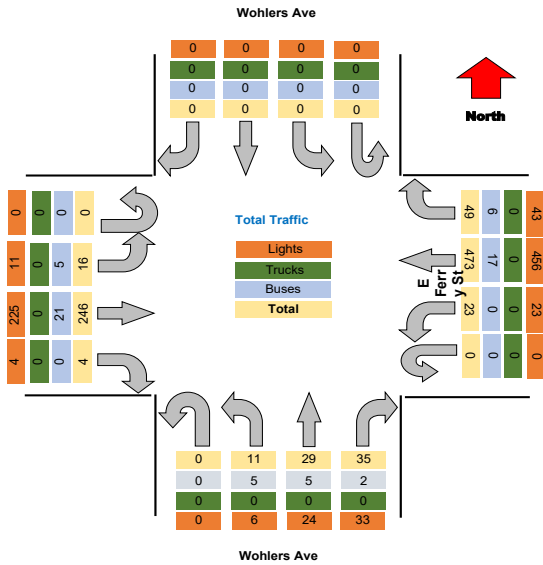

Turning Movement Peak Hour Data (PM)

4:30:00 PM

Leg Direction	Wohlers Ave										E Ferry St										Wohlers Ave										E Ferry St										Total
	Southbound					Westbound					Northbound					Eastbound																									
	Right	Thru	Left	U-Turn	App Total	Right	Thru	Left	U-Turn	App Total	Right	Thru	Left	U-Turn	App Total	Right	Thru	Left	U-Turn	App Total																					
4:30:00 PM	0	0	0	0	0	23	107	7	0	137	10	7	2	0	19	0	0	0	0	0	3	89	14	0	106	3	2	2	2	262											
4:45:00 PM	0	0	0	0	0	25	104	3	0	132	13	13	0	0	26	1	0	0	0	1	0	82	7	0	89	5	0	0	0	247											
5:00:00 PM	0	0	0	0	0	24	101	4	0	129	4	11	2	0	17	1	0	0	0	1	5	75	11	0	91	0	2	0	0	237											
5:15:00 PM	0	0	0	0	0	24	123	1	0	148	8	7	2	0	17	1	0	0	0	1	4	86	14	0	104	0	3	0	0	269											
Grand Total	0	0	0	0	0	96	435	15	0	546	35	39	6	0	79	2	1	0	0	3	12	332	45	0	390	12	7	0	0	1015											
% Approach	#DIV/0!	#DIV/0!	#DIV/0!	#DIV/0!	0.0%	17.6%	79.7%	2.7%	0.0%	0.0%	44.3%	48.1%	7.6%	0.0%	0.0%	0.0%	0.0%	0.0%	0.0%	0.0%	3.1%	85.1%	11.8%	0.0%	0.0%	0.0%	0.0%	0.0%	0.0%	0.0%											
% Total	0.0%	0.0%	0.0%	0.0%	0.0%	9.5%	42.9%	1.5%	0.0%	53.8%	3.4%	3.7%	0.6%	0.0%	7.8%	0.0%	0.0%	0.0%	0.0%	0.0%	1.2%	32.7%	4.5%	0.0%	38.4%	0.0%	0.0%	0.0%	0.0%	0.0%											
PHF	0.000	0.000	0.000	0.000	0.000	0.960	0.884	0.536	0.000	0.922	0.673	0.731	0.750	0.000	0.760	0.000	0.000	0.000	0.000	0.000	0.600	0.933	0.821	0.000	0.920	0.000	0.000	0.000	0.000	0.943											
Lights	0	0	0	0	0	93	425	14	0	532	33	34	4	0	71	0	0	0	0	0	11	322	45	0	378	0	0	0	0	981											
% Lights	0.0%	0.0%	0.0%	0.0%	0.0%	96.9%	97.7%	93.3%	0.0%	97.4%	94.3%	89.5%	66.7%	0.0%	89.9%	0.0%	0.0%	0.0%	0.0%	0.0%	91.7%	97.0%	97.8%	0.0%	96.9%	0.0%	0.0%	0.0%	0.0%	96.7%											
Trucks	0	0	0	0	0	0	0	0	0	0	0	0	0	0	0	0	0	0	0	0	0	0	0	0	0	0	0	0	0	0											
% Trucks	0.0%	0.0%	0.0%	0.0%	0.0%	0.0%	0.0%	0.0%	0.0%	0.0%	0.0%	0.0%	0.0%	0.0%	0.0%	0.0%	0.0%	0.0%	0.0%	0.0%	0.0%	0.0%	0.0%	0.0%	0.0%	0.0%	0.0%	0.0%	0.0%	0.0%											
Buses	0	0	0	0	0	3	10	1	0	14	2	4	2	0	8	0	0	0	0	0	1	9	1	0	11	0	0	0	0	33											
% Buses	0.0%	0.0%	0.0%	0.0%	0.0%	3.1%	2.3%	6.7%	0.0%	0.0%	5.7%	10.5%	33.3%	0.0%	0.0%	0.0%	0.0%	0.0%	0.0%	0.0%	8.3%	2.7%	2.2%	0.0%	0.0%	0.0%	0.0%	0.0%	0.0%	3.3%											
Pedestrians	0	0	0	0	9	0	0	0	0	0	0	0	0	0	2	0	0	0	0	0	0	0	0	0	0	0	12	6	0	0											
% Pedestrians	0.0%	0.0%	0.0%	0.0%	100.0%	0.0%	0.0%	0.0%	0.0%	0.0%	0.0%	0.0%	0.0%	0.0%	0.0%	0.0%	0.0%	0.0%	0.0%	0.0%	0.0%	0.0%	0.0%	0.0%	0.0%	0.0%	100.0%	85.7%	0.0%	0.0%											
Bicycles on Crosswalk	0	0	0	0	1	0	0	0	0	0	0	0	0	0	0	0	0	0	0	0	0	0	0	0	0	0	0	0	0	0											
% Bicycles on Crosswalk	0.0%	0.0%	0.0%	0.0%	0.0%	0.0%	0.0%	0.0%	0.0%	0.0%	0.0%	0.0%	0.0%	0.0%	0.0%	0.0%	0.0%	0.0%	0.0%	0.0%	0.0%	0.0%	0.0%	0.0%	0.0%	0.0%	0.0%	0.0%	0.0%	0.0%											

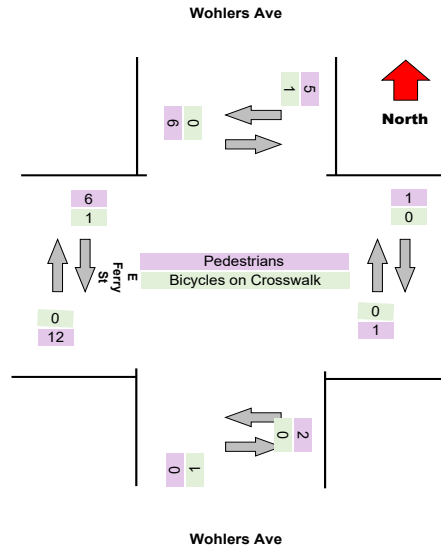
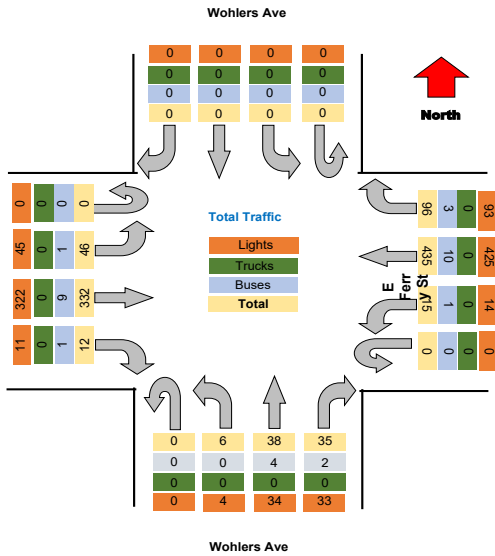

Project : VBH Malta NY
 Site : Site 4
 Location : 42.948550, -73.790036
 Survey Date : 2021-04-28, Wednesday

Turning Movement Data Plot

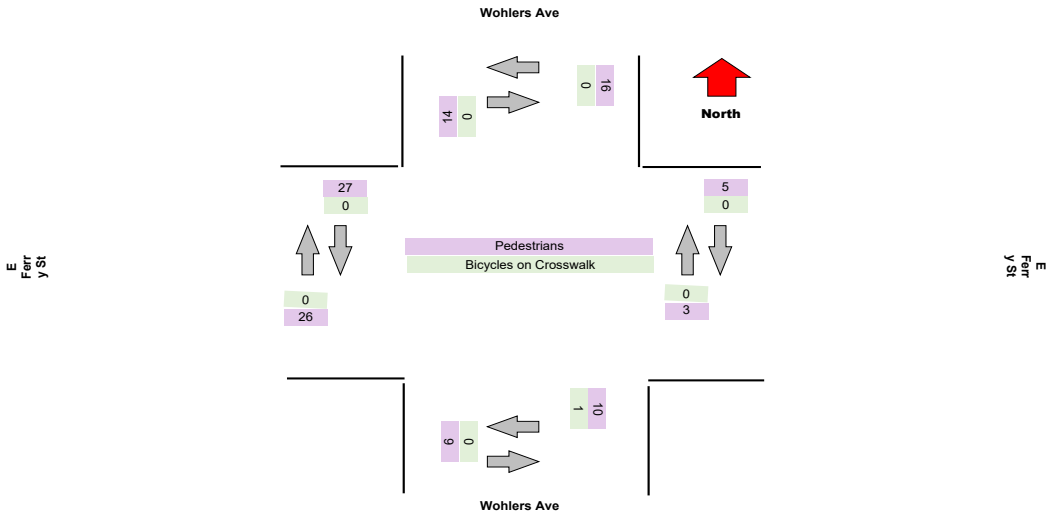
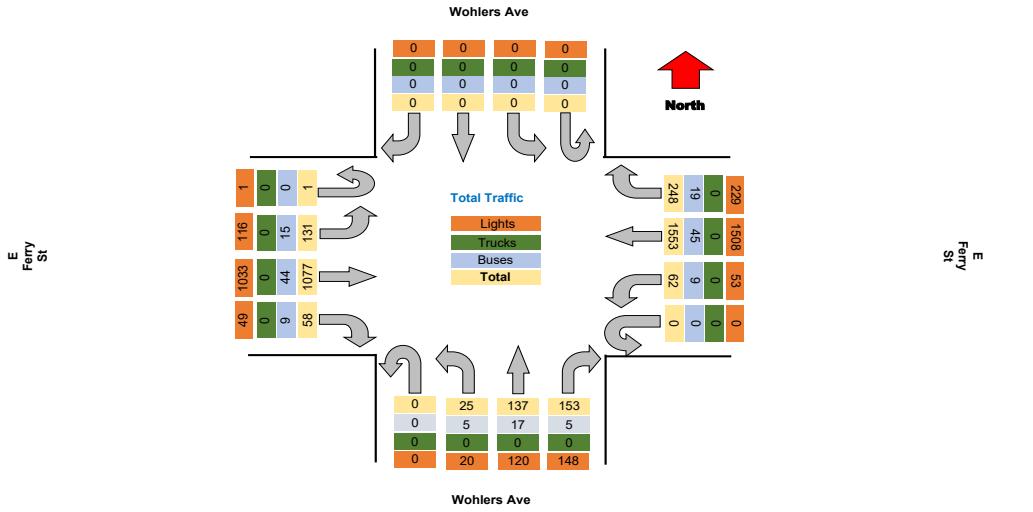

Project : VBH Malta NY
Site : Site 4
Location : 42.948550, -73.790036

TSTData.com

Survey Date : 2021-04-28, Wednesday

Turning Movement Peak Hour Data (AM)

7:30:00 AM

Leg Direction	Wohlers Ave							E Ferry St							Wohlers Ave							E Ferry St							Total
	Southbound				Westbound			Northbound				Eastbound			Northbound				Eastbound										
Start Time	Right	Thru	Left	U-Turn	App Total	Peds CW	Peds CCW	Right	Thru	Left	U-Turn	App Total	Peds CW	Peds CCW	Right	Thru	Left	U-Turn	App Total	Peds CW	Peds CCW	Right	Thru	Left	U-Turn	App Total	Peds CW	Peds CCW	
7:30:00 AM	0	0	0	0	0	0	0	11	114	3	0	128	0	0	9	5	1	0	15	0	1	0	59	4	0	63	0	1	206
7:45:00 AM	0	0	0	0	0	0	0	10	149	3	0	162	0	0	9	6	5	0	20	0	0	1	85	4	0	90	0	0	272
8:00:00 AM	0	0	0	0	0	0	0	15	122	9	0	146	0	0	12	7	1	0	20	1	0	1	75	3	0	79	1	1	245
8:15:00 AM	0	0	0	0	0	0	0	17	83	10	0	110	0	0	8	3	0	0	11	1	0	2	53	10	0	65	2	1	186
Grand Total	0	0	0	0	0	0	0	53	468	25	0	545	0	0	38	21	7	0	55	2	1	4	272	21	0	297	3	3	999
% Approach	#DIV/0!	#DIV/0!	#DIV/0!	#DIV/0!	0.0%	0.0%	0.0%	9.7%	85.7%	4.6%	0.0%	0.0%	0.0%	0.0%	57.6%	31.8%	10.6%	0.0%	0.0%	0.0%	0.0%	1.3%	91.6%	7.1%	0.0%	0.0%	0.0%	0.0%	
% Total	0.0%	0.0%	0.0%	0.0%	0.0%	0.0%	0.0%	5.8%	51.5%	2.8%	0.0%	60.1%	0.0%	0.0%	4.2%	2.3%	0.8%	0.0%	7.3%	0.0%	0.0%	0.4%	29.9%	2.3%	0.0%	32.7%	0.0%	0.0%	
PHF	0.000	0.000	0.000	0.000	0.000	0.000	0.000	0.779	0.785	0.625	0.000	0.843	0.000	0.000	0.792	0.750	0.350	0.000	0.825	0.000	0.000	0.500	0.800	0.525	0.000	0.825	0.000	0.000	0.835
Lights	0	0	0	0	0	0	0	47	447	24	0	518	0	0	36	15	5	0	56	0	0	4	256	15	0	275	0	0	849
% Lights	0.0%	0.0%	0.0%	0.0%	0.0%	0.0%	0.0%	88.7%	95.5%	96.0%	0.0%	94.9%	0.0%	0.0%	84.7%	71.4%	71.4%	0.0%	84.8%	0.0%	0.0%	100.0%	94.1%	71.4%	0.0%	92.6%	0.0%	0.0%	93.4%
Trucks	0	0	0	0	0	0	0	0	0	0	0	0	0	0	0	0	0	0	0	0	0	0	0	0	0	0	0	0	0
% Trucks	0.0%	0.0%	0.0%	0.0%	0.0%	0.0%	0.0%	0.0%	0.0%	0.0%	0.0%	0.0%	0.0%	0.0%	0.0%	0.0%	0.0%	0.0%	0.0%	0.0%	0.0%	0.0%	0.0%	0.0%	0.0%	0.0%	0.0%	0.0%	0.0%
Buses	0	0	0	0	0	0	0	6	21	1	0	28	0	0	2	6	2	0	10	0	0	0	16	6	0	22	0	0	60
% Buses	0.0%	0.0%	0.0%	0.0%	0.0%	0.0%	0.0%	11.3%	4.5%	4.0%	0.0%	0.0%	0.0%	0.0%	5.3%	28.6%	28.6%	0.0%	0.0%	0.0%	0.0%	0.0%	5.9%	28.6%	0.0%	0.0%	0.0%	0.0%	6.6%
Pedestrians	0	0	0	0	0	0	0	0	0	0	0	0	0	0	0	0	0	0	2	1	0	0	0	0	0	0	3	3	6
% Pedestrians	0.0%	0.0%	0.0%	0.0%	0.0%	0.0%	0.0%	0.0%	0.0%	0.0%	0.0%	0.0%	0.0%	0.0%	0.0%	0.0%	0.0%	0.0%	0.0%	100.0%	100.0%	0.0%	0.0%	0.0%	0.0%	0.0%	100.0%	100.0%	0.6%
Bicycles on Crosswalk	0	0	0	0	0	0	0	0	0	0	0	0	0	0	0	0	0	0	0	0	0	0	0	0	0	0	0	0	0
% Bicycles on Crosswalk	0.0%	0.0%	0.0%	0.0%	0.0%	0.0%	0.0%	0.0%	0.0%	0.0%	0.0%	0.0%	0.0%	0.0%	0.0%	0.0%	0.0%	0.0%	0.0%	0.0%	0.0%	0.0%	0.0%	0.0%	0.0%	0.0%	0.0%	0.0%	0.0%

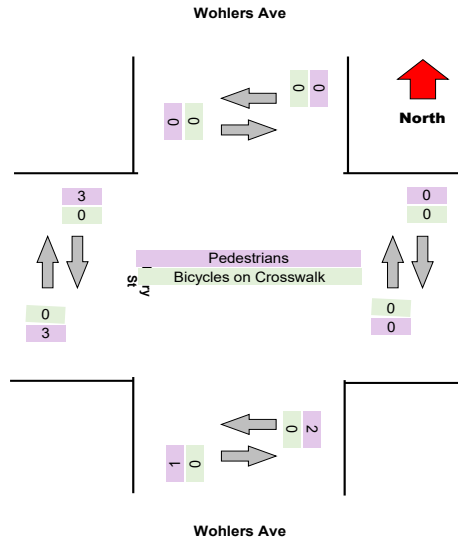
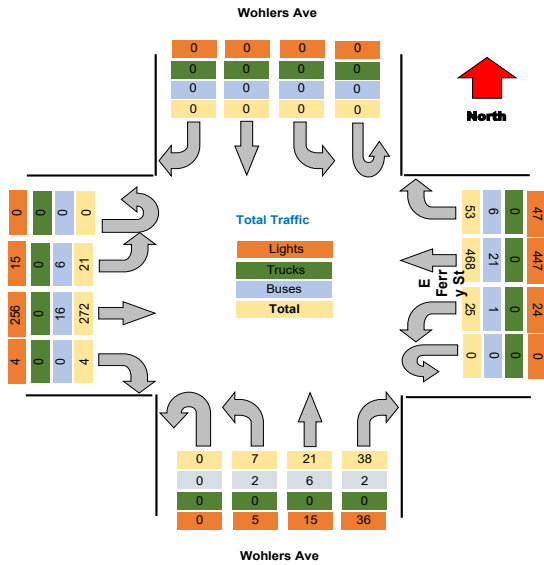

Turning Movement Peak Hour Data (PM)

4:30:00 PM

Leg Direction	Wohlers Ave										E Ferry St										Wohlers Ave										E Ferry St										Total
	Southbound					Westbound					Northbound					Eastbound																									
	Right	Thru	Left	U-Turn	App Total	Right	Thru	Left	U-Turn	App Total	Right	Thru	Left	U-Turn	App Total	Right	Thru	Left	U-Turn	App Total																					
4:30:00 PM	0	0	0	0	0	19	108	7	0	134	17	18	3	0	38	6	105	18	0	129	1	1	1	0	3	301															
4:45:00 PM	0	0	0	0	0	11	119	2	0	132	18	11	0	0	29	3	82	14	0	99	5	1	1	0	7	260															
5:00:00 PM	0	0	0	0	0	28	101	1	0	130	7	15	4	0	26	2	81	8	0	91	10	5	1	0	16	248															
5:15:00 PM	0	0	0	0	0	28	124	4	0	156	11	19	2	0	32	4	81	13	0	98	0	7	1	0	8	277															
Grand Total	0	0	0	0	0	85	452	14	0	552	53	54	9	0	116	15	349	53	0	418	15	14	3	0	32	1086															
% Approach	#DIV/0!	#DIV/0!	#DIV/0!	#DIV/0!	0.0%	15.6%	81.9%	2.5%	0.0%	0.0%	45.7%	46.6%	7.8%	0.0%	0.0%	3.8%	83.5%	12.7%	0.0%	0.0%	0.0%	0.0%	0.0%	0.0%	0.0%																
% Total	0.0%	0.0%	0.0%	0.0%	0.0%	7.9%	41.6%	1.3%	0.0%	50.8%	4.9%	5.0%	0.8%	0.0%	10.7%	1.5%	32.1%	4.9%	0.0%	38.5%	0.0%	0.0%	0.0%	0.0%	0.0%	0.902															
PHF	0.000	0.000	0.000	0.000	0.000	0.768	0.911	0.500	0.000	0.885	0.736	0.750	0.563	0.000	0.763	0.667	0.831	0.736	0.000	0.810	0.000	0.000	0.000	0.000	0.000	0.902															
Lights	0	0	0	0	0	82	444	12	0	538	51	50	7	0	108	14	341	50	0	405	0	0	0	0	0	1051															
% Lights	0.0%	0.0%	0.0%	0.0%	0.0%	85.3%	98.2%	85.7%	0.0%	97.5%	86.2%	92.6%	77.8%	0.0%	93.1%	87.5%	97.7%	94.3%	0.0%	96.9%	0.0%	0.0%	0.0%	0.0%	0.0%	96.8%															
Trucks	0	0	0	0	0	0	0	0	0	0	0	0	0	0	0	0	0	0	0	0	0	0	0	0	0	0															
% Trucks	0.0%	0.0%	0.0%	0.0%	0.0%	0.0%	0.0%	0.0%	0.0%	0.0%	0.0%	0.0%	0.0%	0.0%	0.0%	0.0%	0.0%	0.0%	0.0%	0.0%	0.0%	0.0%	0.0%	0.0%	0.0%	0.0%															
Buses	0	0	0	0	0	4	8	2	0	14	2	4	2	0	8	2	8	3	0	13	0	0	0	0	0	35															
% Buses	0.0%	0.0%	0.0%	0.0%	0.0%	4.7%	1.8%	14.3%	0.0%	0.0%	3.8%	7.4%	22.2%	0.0%	0.0%	12.5%	2.3%	5.7%	0.0%	0.0%	0.0%	0.0%	0.0%	0.0%	0.0%	3.2%															
Pedestrians	0	0	0	0	8	0	0	0	0	0	0	0	0	0	4	0	0	0	0	0	0	0	0	0	16	14															
% Pedestrians	0.0%	0.0%	0.0%	0.0%	100.0%	0.0%	0.0%	0.0%	0.0%	0.0%	0.0%	0.0%	0.0%	0.0%	0.0%	0.0%	0.0%	0.0%	0.0%	0.0%	0.0%	0.0%	0.0%	0.0%	100.0%	0.0%															
Bicycles on Crosswalk	0	0	0	0	0	0	0	0	0	0	0	0	0	0	0	0	0	0	0	0	0	0	0	0	0	0															
% Bicycles on Crosswalk	0.0%	0.0%	0.0%	0.0%	0.0%	0.0%	0.0%	0.0%	0.0%	0.0%	0.0%	0.0%	0.0%	0.0%	0.0%	0.0%	0.0%	0.0%	0.0%	0.0%	0.0%	0.0%	0.0%	0.0%	0.0%	0.0%															

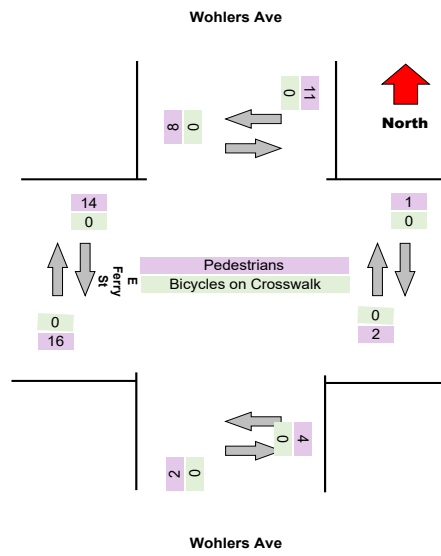
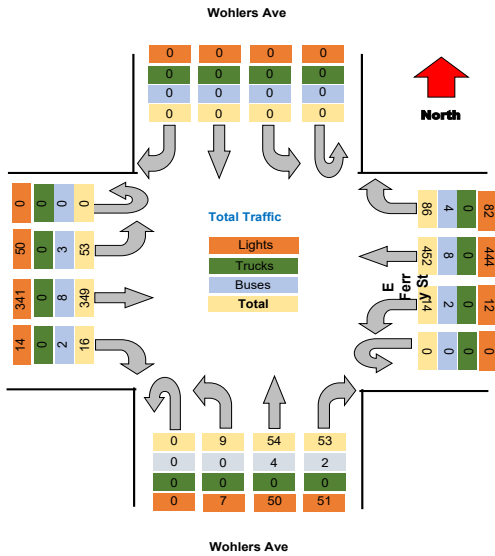

Project : VBH Malta NY
 Site : Site 4
 Location : 42.948550, -73.790036
 Survey Date : 2021-04-28, Wednesday

Turning Movement Data Plot

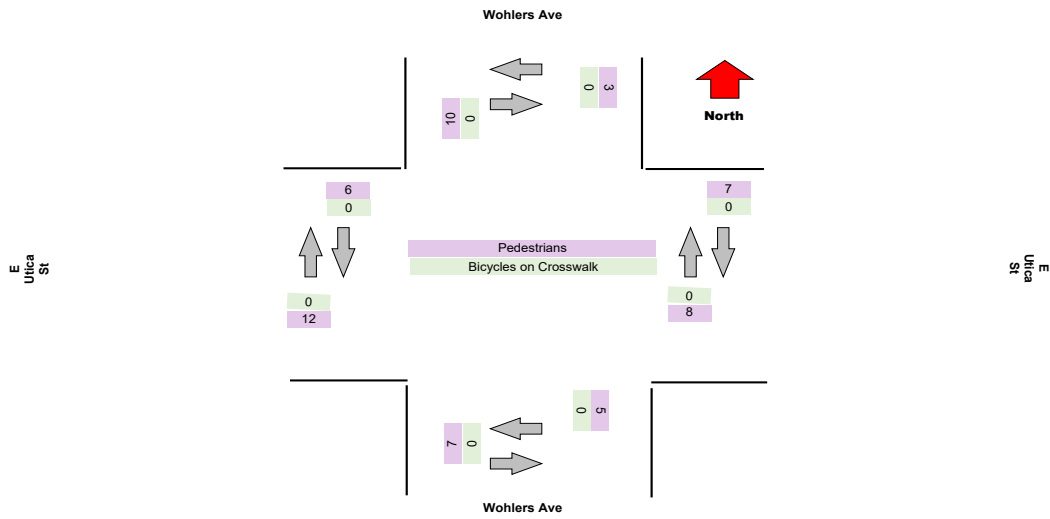
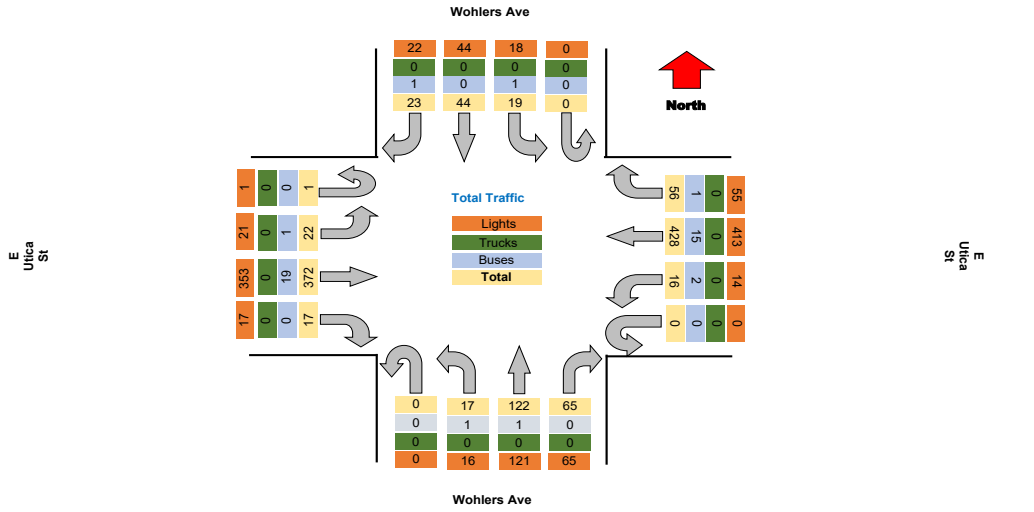

Project : VBH Malta NY
Site : Site 4
Location : 42.948550, -73.790036

TSTData.com

Survey Date : 2021-04-28, Wednesday

Turning Movement Peak Hour Data (AM)

7:30:00 AM

Leg Direction	Wohlers Ave				E Utica St				Wohlers Ave				E Utica St				Total										
	Southbound				Westbound				Northbound				Eastbound														
Start Time	Right	Thru	Left	U-Turn	App Total	Peds CW	Peds CCW	Right	Thru	Left	U-Turn	App Total	Peds CW	Peds CCW	Right	Thru	Left	U-Turn	App Total	Peds CW	Peds CCW						
7:30:00 AM	1	1	0	0	2	0	0	0	14	0	0	14	0	0	3	5	0	0	8	0	0	12	0	0	36		
7:45:00 AM	0	2	1	0	3	0	0	4	19	1	0	24	0	0	1	5	1	0	7	0	1	0	16	0	0	50	
8:00:00 AM	0	2	0	0	2	0	0	5	26	1	0	32	0	0	4	1	1	0	7	0	0	1	21	1	0	64	
8:15:00 AM	0	0	1	0	1	0	0	1	24	1	0	26	0	0	8	4	0	0	12	1	1	1	11	1	0	52	
Grand Total	1	5	2	0	8	0	0	10	83	3	0	96	0	0	16	15	2	0	33	1	2	2	60	2	0	202	
% Approach	12.5%	62.5%	25.0%	0.0%	0.0%	0.0%	0.0%	10.4%	86.6%	3.1%	0.0%	0.0%	0.0%	0.0%	47.1%	44.1%	5.9%	0.0%	0.0%	0.0%	0.0%	0.0%	3.1%	93.8%	3.1%	0.0%	0.0%
% Total	0.5%	2.5%	1.0%	0.0%	4.0%	0.0%	0.0%	5.0%	41.1%	1.5%	0.0%	47.5%	0.0%	0.0%	7.9%	7.4%	1.0%	0.0%	16.8%	0.0%	0.0%	0.0%	1.0%	29.7%	1.0%	0.0%	31.7%
PHF	0.250	0.625	0.500	0.000	0.667	0.000	0.000	0.500	0.788	0.750	0.000	0.750	0.000	0.000	0.500	0.750	0.500	0.000	0.708	0.000	0.000	0.000	0.500	0.714	0.500	0.000	0.696
Lights	1	5	2	0	8	0	0	9	79	3	0	91	0	0	16	15	2	0	33	0	0	2	55	2	0	59	
% Lights	100.0%	100.0%	100.0%	0.0%	100.0%	0.0%	0.0%	80.0%	95.2%	100.0%	0.0%	94.8%	0.0%	0.0%	100.0%	100.0%	100.0%	0.0%	97.1%	0.0%	0.0%	100.0%	91.7%	100.0%	0.0%	92.2%	
Trucks	0	0	0	0	0	0	0	0	0	0	0	0	0	0	0	0	0	0	0	0	0	0	0	0	0	0	0
% Trucks	0.0%	0.0%	0.0%	0.0%	0.0%	0.0%	0.0%	0.0%	0.0%	0.0%	0.0%	0.0%	0.0%	0.0%	0.0%	0.0%	0.0%	0.0%	0.0%	0.0%	0.0%	0.0%	0.0%	0.0%	0.0%	0.0%	0.0%
Buses	0	0	0	0	0	0	0	1	4	0	0	5	0	0	0	0	0	0	0	0	0	0	5	0	0	5	10
% Buses	0.0%	0.0%	0.0%	0.0%	0.0%	0.0%	0.0%	10.0%	4.8%	0.0%	0.0%	0.0%	0.0%	0.0%	0.0%	0.0%	0.0%	0.0%	0.0%	0.0%	0.0%	0.0%	8.3%	0.0%	0.0%	0.0%	
Pedestrians	0	0	0	0	0	0	0	0	0	0	0	0	1	2	0	0	0	0	0	1	2	0	0	0	0	2	
% Pedestrians	0.0%	0.0%	0.0%	0.0%	0.0%	0.0%	0.0%	0.0%	0.0%	0.0%	0.0%	0.0%	0.0%	100.0%	0.0%	0.0%	0.0%	0.0%	0.0%	0.0%	100.0%	100.0%	0.0%	0.0%	100.0%	100.0%	0.0%
Bicycles on Crosswalk	0	0	0	0	0	0	0	0	0	0	0	0	0	0	0	0	0	0	0	0	0	0	0	0	0	0	0
% Bicycles on Crosswalk	0.0%	0.0%	0.0%	0.0%	0.0%	0.0%	0.0%	0.0%	0.0%	0.0%	0.0%	0.0%	0.0%	0.0%	0.0%	0.0%	0.0%	0.0%	0.0%	0.0%	0.0%	0.0%	0.0%	0.0%	0.0%	0.0%	0.0%

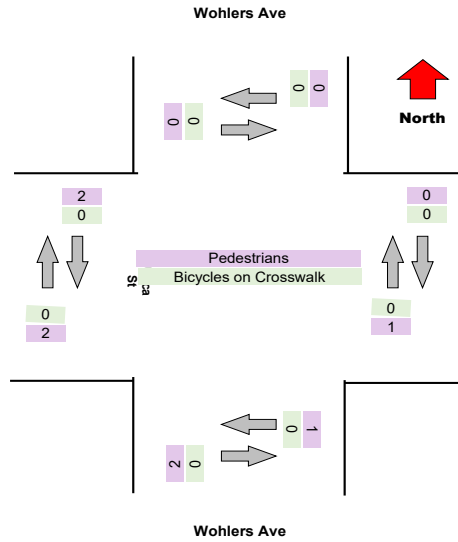
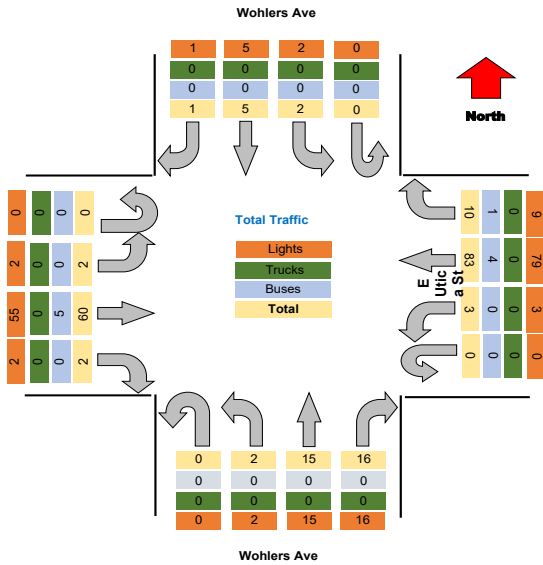

Turning Movement Peak Hour Data (PM)

4:15:00 PM

Leg Direction	Wohlers Ave										E Ulica St										Total										
	Southbound					Westbound					Northbound					Eastbound															
	Right	Thru	Left	U-Turn	App Total	Peds CW	Peds CCW	Right	Thru	Left	U-Turn	App Total	Peds CW	Peds CCW	Right	Thru	Left	U-Turn	App Total	Peds CW		Peds CCW									
4:15:00 PM	7	4	3	0	14	1	0	5	33	1	0	39	0	1	4	12	2	0	18	1	1	1	1	30	2	0	33	2	1	104	
4:30:00 PM	4	5	0	0	9	0	0	4	32	1	0	37	0	0	4	13	4	0	21	1	0	0	2	42	1	0	45	1	0	112	
4:45:00 PM	2	4	3	0	9	1	0	9	42	0	0	51	0	1	5	6	2	0	13	0	0	0	2	33	2	1	37	0	0	110	
5:00:00 PM	2	4	1	0	7	4	0	3	45	4	0	52	1	0	5	9	2	0	16	1	0	0	0	39	2	1	42	3	1	117	
Grand Total	15	17	7	0	39	6	0	21	152	6	0	179	1	2	18	40	10	0	89	3	1	5	144	7	1	157	3	2	443		
% Approach	38.5%	43.6%	17.9%	0.0%	0.0%	0.0%	0.0%	11.7%	84.9%	3.4%	0.0%	0.0%	0.0%	0.0%	26.5%	58.8%	14.7%	0.0%	0.0%	0.0%	0.0%	0.0%	3.2%	91.7%	4.5%	0.6%	0.0%	0.0%	0.0%		
% Total	3.4%	3.8%	1.6%	0.0%	8.8%	0.0%	0.0%	4.7%	34.3%	1.4%	0.0%	40.4%	0.0%	0.0%	4.1%	9.0%	2.3%	0.0%	15.3%	0.0%	0.0%	0.0%	1.1%	32.5%	1.6%	0.2%	35.4%	0.0%	0.0%		
PHF	0.536	0.850	0.583	0.000	0.696	0.000	0.000	0.583	0.844	0.375	0.000	0.861	0.000	0.000	0.900	0.769	0.625	0.000	0.810	0.000	0.000	0.000	0.625	0.857	0.875	0.250	0.872	0.000	0.000	0.947	
Lights	14	17	7	0	38	0	0	21	149	6	0	176	0	0	18	40	10	0	68	0	0	0	5	140	7	1	153	0	0	435	
% Lights	83.3%	100.0%	100.0%	0.0%	97.4%	0.0%	0.0%	100.0%	98.0%	100.0%	0.0%	98.3%	0.0%	0.0%	100.0%	100.0%	100.0%	0.0%	100.0%	0.0%	0.0%	0.0%	100.0%	97.2%	100.0%	#####	97.5%	0.0%	0.0%	98.2%	
Trucks	0	0	0	0	0	0	0	0	0	0	0	0	0	0	0	0	0	0	0	0	0	0	0	0	0	0	0	0	0	0	
% Trucks	0.0%	0.0%	0.0%	0.0%	0.0%	0.0%	0.0%	0.0%	0.0%	0.0%	0.0%	0.0%	0.0%	0.0%	0.0%	0.0%	0.0%	0.0%	0.0%	0.0%	0.0%	0.0%	0.0%	0.0%	0.0%	0.0%	0.0%	0.0%	0.0%	0.0%	
Buses	1	0	0	0	1	0	0	0	3	0	0	3	0	0	0	0	0	0	0	0	0	0	0	4	0	0	4	0	0	8	
% Buses	6.7%	0.0%	0.0%	0.0%	0.0%	0.0%	0.0%	0.0%	2.0%	0.0%	0.0%	0.0%	0.0%	0.0%	0.0%	0.0%	0.0%	0.0%	0.0%	0.0%	0.0%	0.0%	0.0%	2.8%	0.0%	0.0%	0.0%	0.0%	0.0%	1.8%	
Pedestrians	0	0	0	0	0	6	2	0	0	0	0	0	1	2	0	0	0	0	0	3	1	0	0	0	0	0	0	6	2	0	
% Pedestrians	0.0%	0.0%	0.0%	0.0%	0.0%	100.0%	100.0%	0.0%	0.0%	0.0%	0.0%	0.0%	100.0%	100.0%	0.0%	0.0%	0.0%	0.0%	0.0%	0.0%	100.0%	100.0%	0.0%	0.0%	0.0%	0.0%	0.0%	0.0%	100.0%	100.0%	0.0%
Bicycles on Crosswalk	0	0	0	0	0	0	0	0	0	0	0	0	0	0	0	0	0	0	0	0	0	0	0	0	0	0	0	0	0	0	
% Bicycles on Crosswalk	0.0%	0.0%	0.0%	0.0%	0.0%	0.0%	0.0%	0.0%	0.0%	0.0%	0.0%	0.0%	0.0%	0.0%	0.0%	0.0%	0.0%	0.0%	0.0%	0.0%	0.0%	0.0%	0.0%	0.0%	0.0%	0.0%	0.0%	0.0%	0.0%	0.0%	

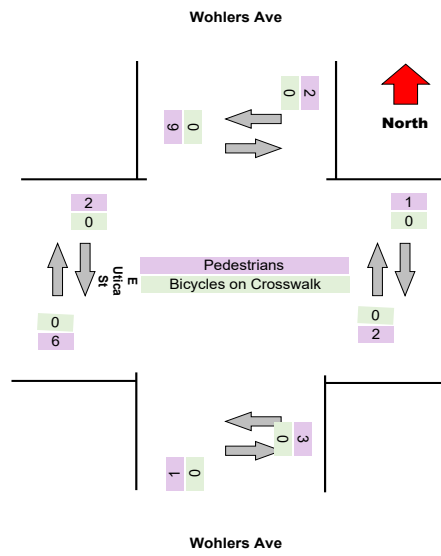
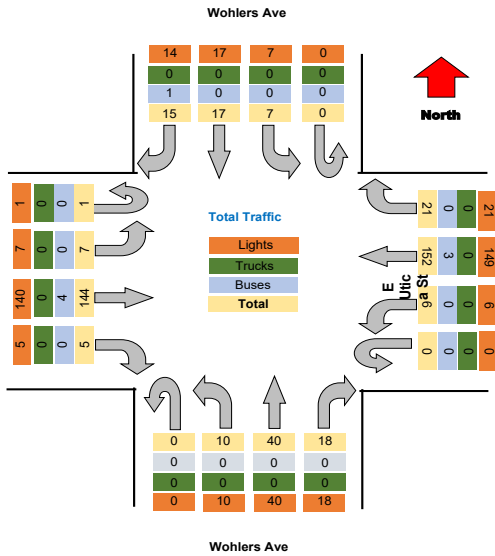

Project : VBH Malta NY
Site : Site 4
Location : 42.948550, -73.790036

TSTData.com

Survey Date : 2021-04-28, Wednesday

Project	LaBella
Project Code	LaBella
Site Name	40
Legs and Movements	All Processed Legs & Move
Bin Size	15 minutes
Survey Date	2021-11-03, Wednesday
Location	40
Latitude and Longitude	42.911066, -78.848082

	Start	End	PHF
Forced Peak AM	2021/11/03 07:30:00	2021/11/03 08:30:00	0.89
Forced Peak PM	2021/11/03 16:30:00	2021/11/03 17:30:00	0.97
AM Peak	2021/11/03 07:30:00	2021/11/03 08:30:00	0.89
PM Peak	2021/11/03 16:15:00	2021/11/03 17:15:00	0.83

Turning Movement Data

Leg Direction	Wohlers Ave										E Utica St										Wohlers Ave										E Utica St										Total
	Southbound					Westbound					Northbound					Eastbound					Southbound					Westbound															
	Right	Thru	Left	U-Turn	App Total	Right	Thru	Left	U-Turn	App Total	Right	Thru	Left	U-Turn	App Total	Right	Thru	Left	U-Turn	App Total	Right	Thru	Left	U-Turn	App Total	Right	Thru	Left	U-Turn	App Total											
6:30:00 AM	0	1	0	0	1	10	0	0	0	11	0	0	0	0	0	4	1	0	0	5	0	0	0	0	0	0	9	0	0	9	0	0	0	0	0	26					
6:45:00 AM	1	3	0	0	4	1	15	1	0	17	0	0	0	0	0	0	2	0	0	2	2	2	2	2	8	1	9	2	0	12	0	0	0	0	0	38					
Hourly Total	1	4	0	0	5	2	25	1	0	28	0	0	0	0	0	4	3	0	0	7	2	2	2	2	8	1	18	2	0	21	0	0	0	0	0	62					
7:00:00 AM	1	2	2	0	5	2	18	2	0	22	0	0	0	0	0	3	3	1	0	7	0	0	0	0	0	1	14	0	0	15	0	0	0	0	0	49					
7:15:00 AM	0	2	1	0	3	3	15	0	0	18	0	0	0	0	0	6	6	5	0	17	0	0	0	0	0	2	8	1	0	11	0	0	0	0	0	49					
7:30:00 AM	2	2	0	0	4	4	22	1	0	28	0	1	0	0	1	4	12	1	0	17	0	0	0	0	0	0	15	5	0	20	1	0	0	0	1	70					
7:45:00 AM	1	2	1	0	4	5	33	1	0	39	4	1	0	0	5	3	3	1	0	7	2	0	0	0	2	2	26	3	0	31	0	0	0	0	0	86					
Hourly Total	4	8	4	0	16	3	14	88	4	107	4	2	0	0	6	16	24	8	0	54	2	0	0	0	2	5	63	9	0	77	1	2	0	0	3	254					
8:00:00 AM	0	4	0	0	4	2	33	1	0	36	0	1	0	0	1	3	4	0	0	7	0	0	0	0	0	4	23	3	0	30	0	0	0	0	0	78					
8:15:00 AM	1	2	0	0	3	4	29	1	0	34	0	1	0	0	1	5	6	0	0	11	0	0	0	0	0	1	23	0	0	24	0	0	0	0	0	73					
Hourly Total	1	6	0	0	7	6	62	2	0	70	0	2	0	0	2	8	10	0	0	20	0	0	0	0	0	5	46	3	0	54	0	0	0	0	0	151					
4:00:00 PM	3	4	9	0	16	3	35	1	0	38	0	2	0	0	2	6	13	2	0	21	0	0	0	0	0	4	43	6	0	53	4	0	0	0	4	128					
4:15:00 PM	3	7	3	0	13	0	0	0	0	0	0	0	0	0	0	2	13	2	0	17	0	0	0	0	0	4	40	6	0	50	0	0	0	0	0	135					
4:30:00 PM	3	4	2	0	9	7	31	1	0	37	0	1	0	0	1	10	8	4	0	22	0	1	0	0	1	2	36	2	0	40	3	1	0	0	4	108					
4:45:00 PM	1	3	1	0	5	9	35	4	0	48	2	1	0	0	3	6	11	3	0	20	0	2	0	0	2	0	32	0	0	32	1	0	0	0	1	105					
Hourly Total	10	18	15	0	43	11	4	27	139	12	0	0	0	12	24	45	11	0	80	0	3	0	0	3	10	151	14	0	175	9	1	0	0	10	476						
5:00:00 PM	2	7	1	0	10	0	0	0	0	0	0	0	0	0	0	3	7	7	0	17	0	1	0	0	1	0	40	4	0	44	1	0	0	0	1	102					
5:15:00 PM	1	1	2	0	4	4	0	0	0	8	0	0	0	0	0	5	10	2	0	17	2	0	0	0	2	3	40	0	0	43	0	0	0	0	0	106					
5:30:00 PM	1	3	1	0	5	0	0	0	0	0	0	0	0	0	0	4	17	0	0	23	0	0	0	0	0	1	29	4	0	34	0	0	0	0	0	107					
5:45:00 PM	1	5	3	0	9	0	0	0	0	0	0	0	0	0	0	8	11	0	0	19	0	0	0	0	0	1	23	3	0	27	0	0	0	0	0	82					
Hourly Total	5	16	7	0	28	0	0	0	0	0	0	0	0	0	0	22	45	9	0	76	2	1	0	0	3	5	132	11	0	148	1	0	0	0	1	397					
Grand Total	21	52	26	0	99	17	6	68	432	27	0	0	0	528	6	9	74	127	28	0	238	6	7	26	410	39	0	475	11	4	0	0	1340								
% Approach	21.2%	52.5%	26.3%	0.0%	0.0%	0.0%	0.0%	12.9%	81.8%	5.1%	0.0%	0.0%	0.0%	0.0%	31.1%	53.4%	11.8%	0.0%	0.0%	0.0%	0.0%	0.0%	0.0%	5.5%	86.3%	8.2%	0.0%	0.0%	0.0%	0.0%	0.0%	0.0%									
% Total	1.6%	3.8%	1.9%	0.0%	7.4%	0.0%	0.0%	5.1%	32.2%	2.0%	0.0%	0.0%	0.0%	0.0%	5.5%	9.5%	2.1%	0.0%	17.8%	0.0%	0.0%	0.0%	0.0%	1.9%	30.6%	2.9%	0.0%	35.4%	0.0%	0.0%	0.0%	0.0%	0.0%								
Lights	17	47	17	0	81	0	0	85	404	25	0	0	0	494	0	0	73	120	22	0	215	0	0	22	379	33	0	434	0	0	0	0	1224								
% Lights	81.0%	90.4%	65.4%	0.0%	81.8%	0.0%	0.0%	95.9%	93.5%	92.6%	0.0%	0.0%	0.0%	93.6%	0.0%	0.0%	88.6%	84.6%	78.6%	0.0%	90.3%	0.0%	0.0%	84.6%	92.4%	84.6%	0.0%	91.4%	0.0%	0.0%	0.0%	0.0%	91.3%								
Trucks	0	0	0	0	0	0	0	0	0	0	0	0	0	0	0	0	0	0	0	0	0	0	0	0	0	0	1	0	0	1	0	0	0	0	1						
% Trucks	0.0%	0.0%	0.0%	0.0%	0.0%	0.0%	0.0%	0.0%	0.0%	0.0%	0.0%	0.0%	0.0%	0.0%	0.0%	0.0%	0.0%	0.0%	0.0%	0.0%	0.0%	0.0%	0.0%	0.0%	0.2%	0.0%	0.0%	0.2%	0.0%	0.0%	0.0%	0.0%	0.1%								
Buses	4	5	9	0	18	0	0	3	28	2	0	0	0	33	0	0	1	7	6	0	14	0	0	4	30	6	0	40	0	0	0	0	106								
% Buses	19.0%	9.6%	34.6%	0.0%	0.0%	0.0%	0.0%	0.0%	6.5%	7.4%	0.0%	0.0%	0.0%	0.0%	1.4%	5.5%	21.4%	0.0%	0.0%	0.0%	0.0%	0.0%	0.0%	15.4%	7.3%	15.4%	0.0%	0.0%	0.0%	0.0%	0.0%	0.0%	7.8%								
Pedestrians	0	0	0	0	0	0	0	0	0	0	0	0	0	0	0	0	0	0	0	0	0	0	0	0	0	0	0	0	0	0	11	4	0	0	0						
% Pedestrians	0.0%	0.0%	0.0%	0.0%	0.0%	0.0%	0.0%	0.0%	0.0%	0.0%	0.0%	0.0%	0.0%	0.0%	0.0%	0.0%	0.0%	0.0%	0.0%	0.0%	0.0%	0.0%	0.0%	0.0%	0.0%	0.0%	0.0%	0.0%	0.0%	100.0%	100.0%	0.0%	0.0%								
Bicycles on Crosswalk	0	0	0	0	0	0	0	0	0	0	2	0	0	0	2	0	0	0	0	0	0	0	0	0	0	0	0	0	0	0	0	0	0	0	0						
% Bicycles on Crosswalk	0.0%	0.0%	0.0%	0.0%	0.0%	0.0%	0.0%	0.0%	0.0%	0.0%	0.0%	33.3%	0.0%	0.0%	0.0%	0.0%	0.0%	0.0%	0.0%	0.0%	0.0%	0.0%	0.0%	0.0%	0.0%	0.0%	0.0%	0.0%	0.0%	0.0%	0.0%	0.0%	0.0%								

Project : VBH Malta NY
 Site : Site 4
 Location : 42.948550, -73.790036
 Survey Date : 2021-04-28, Wednesday

Turning Movement Data Plot

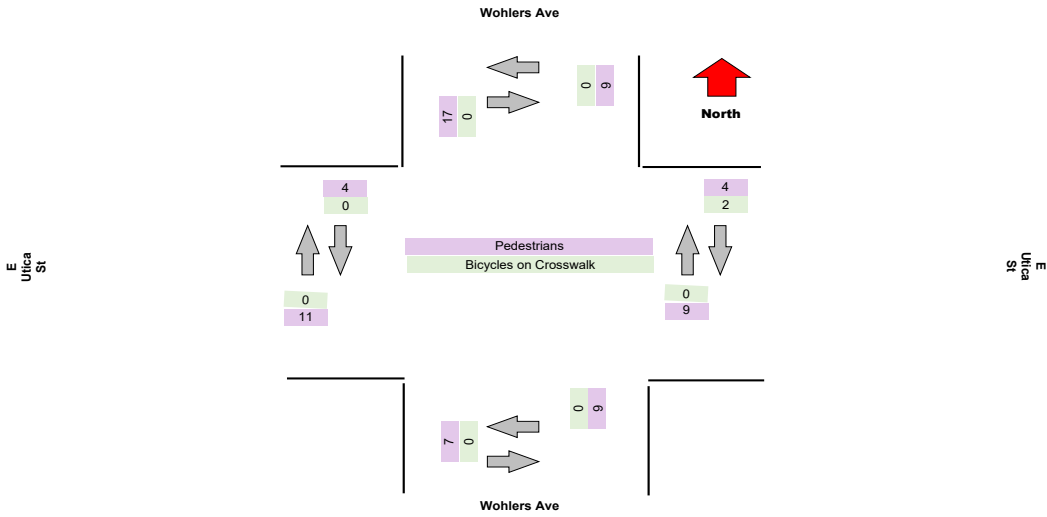
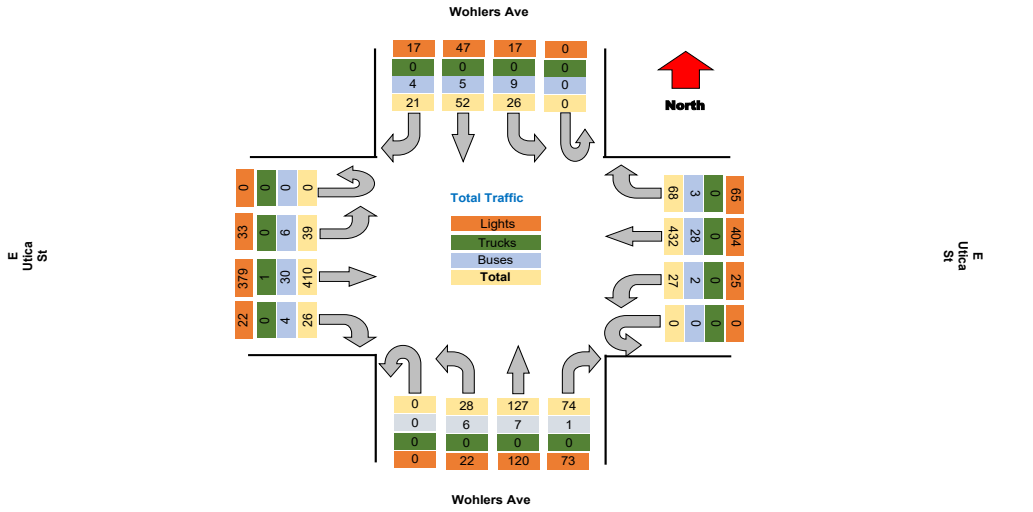

Project : VBH Malta NY
Site : Site 4
Location : 42.948550, -73.790036

TSTData.com

Survey Date : 2021-04-28, Wednesday

Turning Movement Peak Hour Data (AM)

7:30:00 AM

Leg Direction	Wohlers Ave								E Ulrica St								Wohlers Ave								E Ulrica St								Total
	Southbound				Westbound				Northbound				Eastbound				Northbound				Eastbound												
Start Time	Right	Thru	Left	U-Turn	App Total	Peds CW	Peds CCW		Right	Thru	Left	U-Turn	App Total	Peds CW	Peds CCW		Right	Thru	Left	U-Turn	App Total	Peds CW	Peds CCW		Right	Thru	Left	U-Turn	App Total	Peds CW	Peds CCW		
7:30:00 AM	2	2	0	0	4	1	1		4	22	1	0	28	0	1		4	12	1	0	18	0	0		0	15	5	0	20	1	0		70
7:45:00 AM	1	2	1	0	4	0	0		5	33	1	0	39	4	1		3	3	1	0	12	2	0		2	26	3	0	31	0	1		86
8:00:00 AM	0	4	0	0	4	1	0		2	33	1	0	36	0	1		3	4	0	0	8	0	1		4	23	3	0	30	0	0		78
8:15:00 AM	1	2	0	0	3	1	0		4	29	1	0	34	0	1		5	5	0	0	12	0	0		1	23	0	0	24	0	0		73
Grand Total	4	10	1	0	15	3	1		15	117	4	0	137	4	2		15	25	2	0	50	2	1		7	87	11	0	105	1	1		397
% Approach	26.7%	66.7%	6.7%	0.0%	0.0%	0.0%	0.0%		10.0%	85.4%	2.9%	0.0%	0.0%	0.0%	0.0%		30.0%	50.0%	4.0%	0.0%	0.0%	0.0%	0.0%		6.7%	82.9%	10.5%	0.0%	0.0%	0.0%	0.0%		
% Total	1.3%	3.3%	0.3%	0.0%	4.9%	0.0%	0.0%		4.9%	38.1%	1.3%	0.0%	44.6%	0.0%	0.0%		4.9%	8.1%	0.7%	0.0%	16.3%	0.0%	0.0%		2.3%	28.3%	3.6%	0.0%	34.2%	0.0%	0.0%		
PHF	0.500	0.625	0.250	0.000	0.938	0.000	0.000		0.750	0.886	1.000	0.000	0.878	0.000	0.000		0.750	0.521	0.500	0.000	0.684	0.000	0.000		0.438	0.837	0.550	0.000	0.847	0.000	0.000		0.892
Lights	4	9	1	0	14	0	0		15	107	4	0	126	0	0		15	22	1	0	38	0	0		5	76	10	0	91	0	0		269
% Lights	100.0%	90.0%	100.0%	0.0%	93.3%	0.0%	0.0%		100.0%	91.5%	100.0%	0.0%	92.0%	0.0%	0.0%		100.0%	88.0%	50.0%	0.0%	76.0%	0.0%	0.0%		71.4%	87.4%	90.9%	0.0%	86.7%	0.0%	0.0%		87.6%
Trucks	0	0	0	0	0	0	0		0	0	0	0	0	0	0		0	0	0	0	0	0	0		0	0	0	0	0	0	0		0
% Trucks	0.0%	0.0%	0.0%	0.0%	0.0%	0.0%	0.0%		0.0%	0.0%	0.0%	0.0%	0.0%	0.0%	0.0%		0.0%	0.0%	0.0%	0.0%	0.0%	0.0%	0.0%		0.0%	0.0%	0.0%	0.0%	0.0%	0.0%	0.0%		0.0%
Buses	0	1	0	0	1	0	0		0	10	0	0	10	0	0		0	3	1	0	4	0	0		2	11	1	0	14	0	0		29
% Buses	0.0%	10.0%	0.0%	0.0%	0.0%	0.0%	0.0%		0.0%	8.5%	0.0%	0.0%	0.0%	0.0%	0.0%		0.0%	12.0%	50.0%	0.0%	0.0%	0.0%	0.0%		28.6%	12.6%	9.1%	0.0%	0.0%	0.0%	0.0%		9.4%
Pedestrians	0	0	0	0	0	3	1		0	0	0	0	2	4	0		0	0	0	0	2	1	0		0	0	0	0	0	1	1		0
% Pedestrians	0.0%	0.0%	0.0%	0.0%	0.0%	100.0%	100.0%		0.0%	0.0%	0.0%	0.0%	50.0%	100.0%	0.0%		0.0%	0.0%	0.0%	0.0%	0.0%	100.0%	100.0%		0.0%	0.0%	0.0%	0.0%	0.0%	100.0%	100.0%		0.0%
Bicycles on Crosswalk	0	0	0	0	0	0	0		0	0	0	0	2	0	0		0	0	0	0	0	0	0		0	0	0	0	0	0	0		0
% Bicycles on Crosswalk	0.0%	0.0%	0.0%	0.0%	0.0%	0.0%	0.0%		0.0%	0.0%	0.0%	0.0%	0.0%	50.0%	0.0%		0.0%	0.0%	0.0%	0.0%	0.0%	0.0%	0.0%		0.0%	0.0%	0.0%	0.0%	0.0%	0.0%	0.0%		0.0%

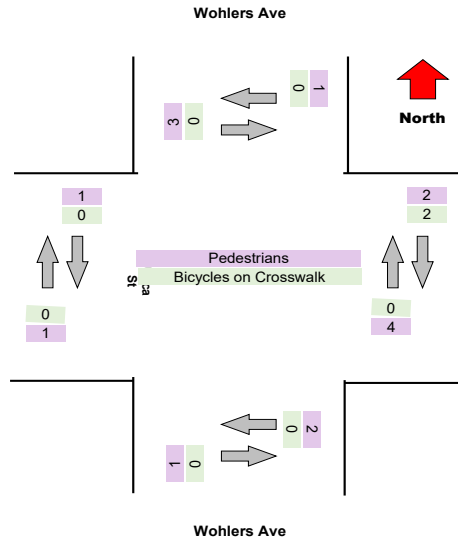
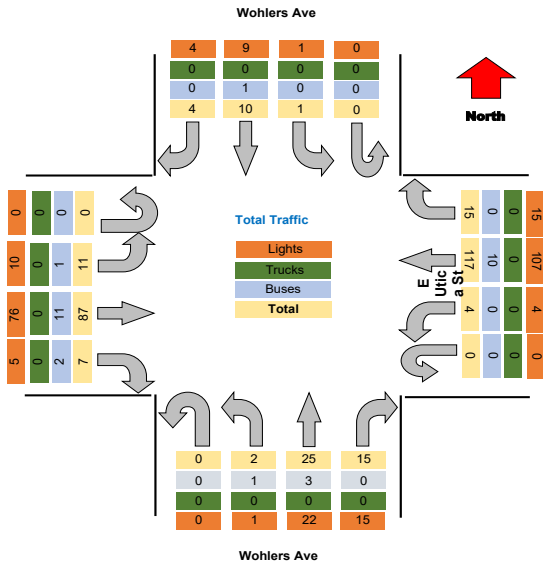

Turning Movement Peak Hour Data (PM)

4:15:00 PM

Leg Direction	Wohlers Ave										E Utica St										Total
	Southbound					Westbound					Northbound					Eastbound					
	Right	Thru	Left	U-Turn	App Total	Right	Thru	Left	U-Turn	App Total	Right	Thru	Left	U-Turn	App Total	Right	Thru	Left	U-Turn	App Total	
4:15:00 PM	3	7	3	0	13	11	38	6	0	55	2	13	2	0	17	4	40	6	0	50	135
4:30:00 PM	3	4	2	0	9	5	31	1	0	37	10	8	4	0	22	2	36	2	0	40	108
4:45:00 PM	1	3	1	0	5	9	35	4	0	48	6	11	3	0	20	0	32	0	0	32	105
5:00:00 PM	2	7	1	0	10	3	27	1	0	31	3	7	7	0	17	0	40	4	0	44	102
Grand Total	9	21	7	0	37	28	131	12	0	171	21	39	16	0	76	6	148	12	0	166	450
% Approach	24.3%	56.8%	18.9%	0.0%	0.0%	16.4%	76.6%	7.0%	0.0%	0.0%	27.6%	51.3%	21.1%	0.0%	0.0%	3.6%	89.2%	7.2%	0.0%	0.0%	
% Total	2.0%	4.7%	1.6%	0.0%	8.2%	6.2%	29.1%	2.7%	0.0%	38.0%	4.7%	8.7%	3.6%	0.0%	16.9%	1.3%	32.9%	2.7%	0.0%	36.9%	
PHF	0.750	0.750	0.583	0.000	0.712	0.636	0.882	0.500	0.000	0.777	0.525	0.750	0.571	0.000	0.864	0.375	0.925	0.500	0.000	0.830	0.833
Lights	7	20	5	0	32	27	124	11	0	162	21	38	13	0	72	5	140	12	0	157	423
% Lights	77.8%	95.2%	71.4%	0.0%	86.5%	96.4%	94.7%	91.7%	0.0%	94.7%	100.0%	97.4%	81.3%	0.0%	94.7%	83.3%	94.6%	100.0%	0.0%	94.6%	94.0%
Trucks	0	0	0	0	0	0	0	0	0	0	0	0	0	0	0	0	1	0	0	1	1
% Trucks	0.0%	0.0%	0.0%	0.0%	0.0%	0.0%	0.0%	0.0%	0.0%	0.0%	0.0%	0.0%	0.0%	0.0%	0.0%	0.0%	0.7%	0.0%	0.0%	0.6%	0.2%
Buses	2	1	2	0	5	1	7	1	0	9	0	1	3	0	4	1	7	0	0	8	26
% Buses	22.2%	4.8%	28.6%	0.0%	0.0%	3.6%	5.3%	8.3%	0.0%	0.0%	0.0%	2.6%	18.8%	0.0%	0.0%	16.7%	4.7%	0.0%	0.0%	0.0%	5.8%
Pedestrians	0	0	0	0	0	0	0	0	0	0	0	0	0	0	0	0	0	0	0	0	6
% Pedestrians	0.0%	0.0%	0.0%	0.0%	0.0%	0.0%	0.0%	0.0%	0.0%	0.0%	0.0%	0.0%	0.0%	0.0%	0.0%	0.0%	0.0%	0.0%	0.0%	0.0%	100.0%
Bicycles on Crosswalk	0	0	0	0	0	0	0	0	0	0	0	0	0	0	0	0	0	0	0	0	0
% Bicycles on Crosswalk	0.0%	0.0%	0.0%	0.0%	0.0%	0.0%	0.0%	0.0%	0.0%	0.0%	0.0%	0.0%	0.0%	0.0%	0.0%	0.0%	0.0%	0.0%	0.0%	0.0%	0.0%

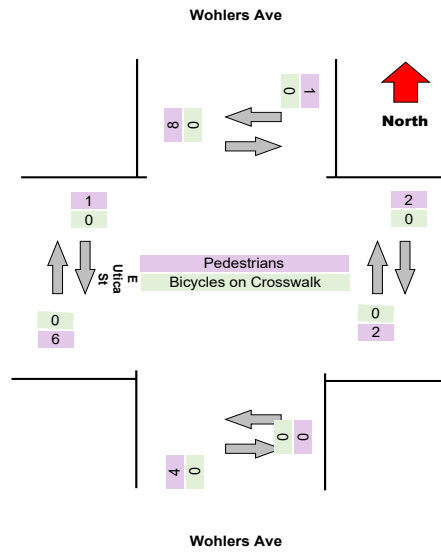
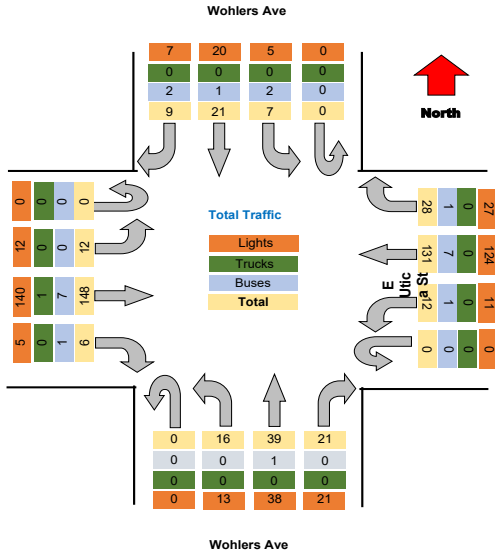

Project : VBH Malta NY
Site : Site 4
Location : 42.948550, -73.790036

TSTData.com

Survey Date : 2021-04-28, Wednesday

Project	LaBella
Project Code	LaBella
Site Name	40
Legs and Movements	All Processed Legs & Move
Bin Size	15 minutes
Survey Date	2021-11-04, Thursday
Location	40
Latitude and Longitude	42.911066, -78.848082

	Start	End	PHF
Forced Peak AM	2021/11/04 07:30:00	2021/11/04 08:30:00	0.91
Forced Peak PM	2021/11/04 16:30:00	2021/11/04 17:30:00	0.91
AM Peak	2021/11/04 07:30:00	2021/11/04 08:30:00	0.91
PM Peak	2021/11/04 16:15:00	2021/11/04 17:15:00	0.96

Turning Movement Data

Leg Direction	Wohlers Ave								E Utica St								Wohlers Ave								E Utica St								Total
	Southbound				Westbound				Northbound				Eastbound				Southbound				Westbound				Northbound				Eastbound				
	Right	Thru	Left	U-Turn	App Total	Peds CV	Peds CCW	Peds CCW	Right	Thru	Left	U-Turn	App Total	Peds CV	Peds CCW	Peds CCW	Right	Thru	Left	U-Turn	App Total	Peds CV	Peds CCW	Peds CCW	Right	Thru	Left	U-Turn	App Total	Peds CV	Peds CCW	Peds CCW	
6:30:00 AM	0	2	0	0	2	1	0	0	0	8	0	0	8	0	0	0	4	0	0	0	4	0	0	0	0	3	0	0	3	0	0	0	17
6:45:00 AM	2	2	0	0	4	0	0	0	2	9	0	0	12	1	1	1	1	5	1	0	9	2	1	1	0	7	2	0	9	0	0	0	34
Hourly Total	2	4	0	0	6	1	0	0	2	17	0	0	20	1	1	1	5	5	1	0	13	2	1	1	0	10	2	0	12	0	0	0	51
7:00:00 AM	1	3	3	0	7	0	0	0	1	19	3	0	23	0	0	0	2	4	0	0	6	0	0	0	0	13	0	0	13	0	0	0	49
7:15:00 AM	1	2	0	0	3	0	0	0	6	22	1	0	30	1	0	0	2	3	1	0	7	0	0	0	1	11	2	0	14	0	0	0	54
7:30:00 AM	4	0	1	0	5	0	0	0	3	28	0	0	31	0	0	0	2	6	2	0	10	0	0	0	1	19	1	0	21	0	0	0	67
7:45:00 AM	1	3	0	0	4	0	0	0	5	32	0	0	38	0	0	0	7	5	1	0	13	0	0	0	3	20	1	0	24	0	0	0	79
Hourly Total	7	8	4	0	19	0	0	0	15	101	4	0	122	1	0	0	13	18	4	0	36	0	0	0	5	63	4	0	72	0	0	0	249
8:00:00 AM	2	2	3	0	7	0	0	0	8	32	1	0	41	0	0	0	3	5	0	0	8	0	0	0	0	24	1	0	26	0	0	0	81
8:15:00 AM	1	2	4	0	7	0	0	0	7	25	3	0	36	0	0	0	5	6	0	0	11	0	0	0	1	12	2	0	15	0	0	0	69
Hourly Total	3	4	7	0	14	0	0	0	15	57	4	0	77	0	0	0	8	11	0	0	19	0	0	0	1	36	3	0	40	0	0	0	150
4:00:00 PM	1	4	7	0	12	0	0	0	4	37	3	0	44	0	0	0	1	17	2	0	20	0	0	0	1	41	3	0	45	1	0	0	121
4:15:00 PM	2	9	1	0	12	4	1	1	4	39	3	0	46	1	0	0	5	13	3	0	21	0	0	0	3	38	1	0	42	2	1	0	121
4:30:00 PM	0	4	1	0	5	6	3	3	1	29	2	0	32	0	0	0	6	23	1	0	30	0	0	0	2	37	3	0	42	0	0	0	109
4:45:00 PM	0	5	2	0	7	3	2	2	7	42	3	0	52	0	0	0	5	10	3	0	18	0	0	0	1	39	6	0	46	3	0	0	123
Hourly Total	3	22	11	0	36	13	7	7	16	147	11	0	174	1	0	0	17	63	9	0	89	0	0	0	7	155	13	0	175	6	3	0	474
5:00:00 PM	4	3	2	0	9	0	0	0	8	36	3	0	47	0	0	0	13	7	4	0	24	1	1	1	3	33	2	0	38	2	0	0	118
5:15:00 PM	2	3	1	0	6	0	0	0	6	34	2	0	42	1	0	0	7	9	1	0	17	2	1	0	0	32	1	0	33	2	1	0	98
5:30:00 PM	4	1	5	0	10	0	0	0	6	35	3	0	44	2	0	0	3	13	1	0	17	1	1	1	3	26	1	0	30	0	0	0	101
5:45:00 PM	1	4	1	0	6	3	2	2	9	29	1	0	39	0	0	0	5	9	3	0	17	1	1	1	0	21	1	0	22	2	0	0	84
Hourly Total	11	11	9	0	31	3	3	3	29	134	9	0	172	3	1	0	28	38	9	0	76	5	4	4	6	112	5	0	123	6	1	0	461
Grand Total	28	49	31	0	108	17	14	14	77	456	28	0	565	6	2	2	71	135	23	0	232	7	7	7	19	376	27	0	422	12	6	0	1328
% Approach	24.5%	46.2%	29.2%	0.0%	0.0%	0.0%	0.0%	0.0%	13.6%	80.7%	5.0%	0.0%	0.0%	0.0%	0.0%	0.0%	30.6%	58.2%	9.9%	0.0%	0.0%	0.0%	0.0%	0.0%	4.5%	89.1%	6.4%	0.0%	0.0%	0.0%	0.0%	0.0%	0.0%
% Total	2.0%	3.7%	2.3%	0.0%	8.0%	0.0%	0.0%	0.0%	5.8%	34.4%	2.1%	0.0%	42.6%	0.0%	0.0%	0.0%	5.4%	10.2%	1.7%	0.0%	17.5%	0.0%	0.0%	0.0%	1.4%	28.4%	2.0%	0.0%	31.8%	0.0%	0.0%	0.0%	0.0%
Lights	21	41	21	0	83	0	0	0	74	430	24	0	528	0	0	0	71	130	19	0	220	0	0	0	15	346	22	0	383	0	0	0	1214
% Lights	80.8%	83.7%	67.7%	0.0%	78.3%	0.0%	0.0%	0.0%	56.1%	84.3%	85.7%	0.0%	83.5%	0.0%	0.0%	0.0%	100.0%	86.3%	82.8%	0.0%	84.8%	0.0%	0.0%	0.0%	78.9%	92.0%	81.5%	0.0%	90.8%	0.0%	0.0%	0.0%	91.6%
Trucks	0	0	0	0	0	0	0	0	0	0	0	0	0	0	0	0	0	0	0	0	0	0	0	0	0	0	0	0	0	0	0	0	0
% Trucks	0.0%	0.0%	0.0%	0.0%	0.0%	0.0%	0.0%	0.0%	0.0%	0.0%	0.0%	0.0%	0.0%	0.0%	0.0%	0.0%	0.0%	0.0%	0.0%	0.0%	0.0%	0.0%	0.0%	0.0%	0.0%	0.0%	0.0%	0.0%	0.0%	0.0%	0.0%	0.0%	0.0%
Buses	5	8	10	0	23	0	0	0	3	26	4	0	33	0	0	0	0	5	4	0	9	0	0	0	3	30	5	0	38	0	0	0	103
% Buses	19.2%	16.3%	32.3%	0.0%	0.0%	0.0%	0.0%	0.0%	0.0%	5.7%	14.3%	0.0%	0.0%	0.0%	0.0%	0.0%	0.0%	3.7%	17.4%	0.0%	0.0%	0.0%	0.0%	0.0%	15.8%	8.0%	18.5%	0.0%	0.0%	0.0%	0.0%	0.0%	7.8%
Pedestrians	0	0	0	0	0	17	14	0	0	0	0	0	0	6	2	0	0	0	0	0	0	6	6	0	0	0	0	0	0	12	6	0	0
% Pedestrians	0.0%	0.0%	0.0%	0.0%	0.0%	100.0%	100.0%	0.0%	0.0%	0.0%	0.0%	0.0%	0.0%	100.0%	100.0%	0.0%	0.0%	0.0%	0.0%	0.0%	0.0%	85.7%	85.7%	0.0%	0.0%	0.0%	0.0%	0.0%	0.0%	100.0%	100.0%	0.0%	0.0%
Bicycles on Crosswalk	0	0	0	0	0	0	0	0	0	0	0	0	0	0	0	0	0	0	0	0	0	1	1	0	0	0	0	0	0	0	0	0	0
% Bicycles on Crosswalk	0.0%	0.0%	0.0%	0.0%	0.0%	0.0%	0.0%	0.0%	0.0%	0.0%	0.0%	0.0%	0.0%	0.0%	0.0%	0.0%	0.0%	0.0%	0.0%	0.0%	0.0%	14.3%	14.3%	0.0%	0.0%	0.0%	0.0%	0.0%	0.0%	0.0%	0.0%	0.0%	0.0%

Turning Movement Data Plot

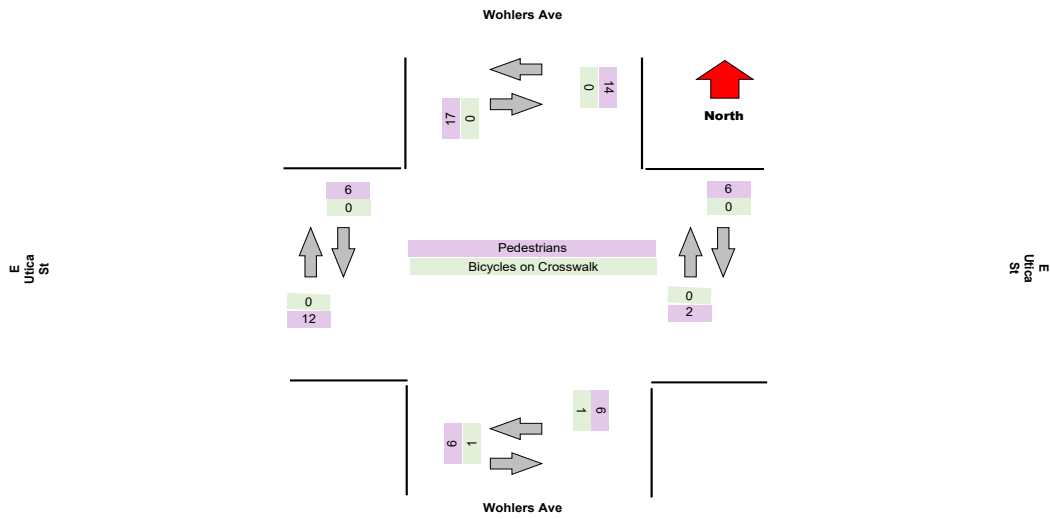
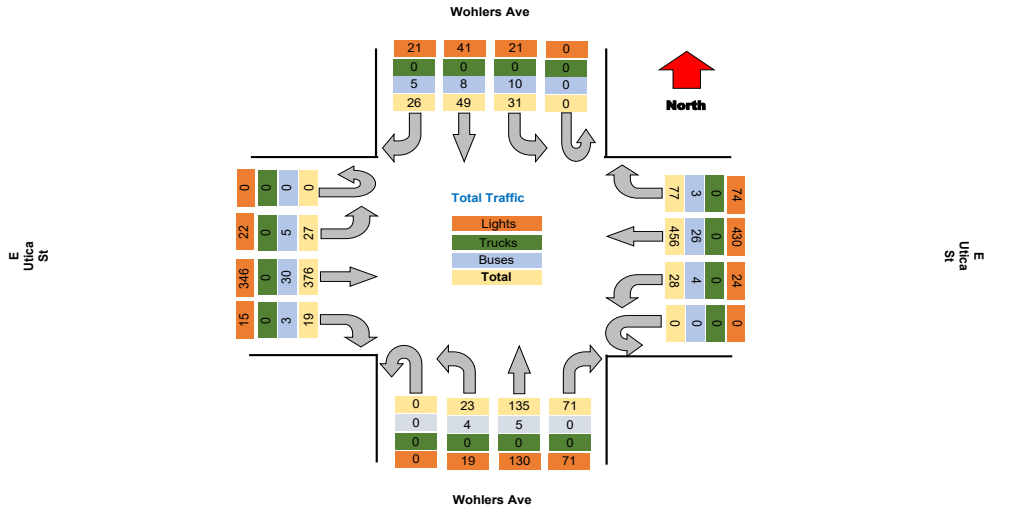

Turning Movement Peak Hour Data (AM)

7:30:00 AM

Leg Direction	Wohlers Ave								E Ulica St								Wohlers Ave								E Ulica St								Total
	Southbound				Westbound				Northbound				Eastbound				Northbound				Eastbound												
Start Time	Right	Thru	Left	U-Turn	App Total	Peds CW	Peds CCW		Right	Thru	Left	U-Turn	App Total	Peds CW	Peds CCW		Right	Thru	Left	U-Turn	App Total	Peds CW	Peds CCW		Right	Thru	Left	U-Turn	App Total	Peds CW	Peds CCW		
7:30:00 AM	4	0	1	0	5	0	0		3	28	0	0	31	0	0		2	6	2	0	10	0	0		1	19	1	0	21	0	1		67
7:45:00 AM	1	3	0	0	4	0	1		5	32	0	0	38	0	0		7	5	1	0	13	0	1		3	20	1	0	24	0	0		79
8:00:00 AM	2	2	3	0	7	0	0		8	32	1	0	41	0	0		3	5	0	0	8	0	0		0	24	1	0	25	0	0		81
8:15:00 AM	1	2	4	0	7	0	0		7	25	3	0	35	0	0		5	6	0	0	11	0	0		1	12	2	0	15	0	0		69
Grand Total	8	7	8	0	23	0	0		23	117	4	0	146	0	0		17	22	3	0	42	0	1		5	75	5	0	85	0	1		296
% Approach	34.8%	30.4%	34.8%	0.0%	0.0%	0.0%	0.0%		15.6%	80.1%	2.7%	0.0%	0.0%	0.0%	0.0%		40.5%	52.4%	7.1%	0.0%	0.0%	0.0%	0.0%		5.9%	85.2%	5.9%	0.0%	0.0%	0.0%	0.0%		
% Total	2.7%	2.4%	2.7%	0.0%	7.8%	0.0%	0.0%		7.8%	39.5%	1.4%	0.0%	49.3%	0.0%	0.0%		5.7%	7.4%	1.0%	0.0%	14.2%	0.0%	0.0%		1.7%	25.3%	1.7%	0.0%	28.7%	0.0%	0.0%		
PHF	0.500	0.583	0.500	0.000	0.821	0.000	0.000		0.719	0.914	0.333	0.000	0.890	0.000	0.000		0.607	0.917	0.375	0.000	0.808	0.000	0.000		0.417	0.781	0.625	0.000	0.850	0.000	0.000		0.914
Lights	8	6	7	0	21	0	0		22	107	3	0	132	0	0		17	20	2	0	39	0	0		2	64	4	0	70	0	0		262
% Lights	100.0%	85.7%	87.5%	0.0%	91.3%	0.0%	0.0%		95.7%	91.5%	75.0%	0.0%	90.4%	0.0%	0.0%		100.0%	90.9%	66.7%	0.0%	92.9%	0.0%	0.0%		40.0%	85.3%	80.0%	0.0%	82.4%	0.0%	0.0%		88.5%
Trucks	0	0	0	0	0	0	0		0	0	0	0	0	0	0		0	0	0	0	0	0	0		0	0	0	0	0	0	0		0
% Trucks	0.0%	0.0%	0.0%	0.0%	0.0%	0.0%	0.0%		0.0%	0.0%	0.0%	0.0%	0.0%	0.0%	0.0%		0.0%	0.0%	0.0%	0.0%	0.0%	0.0%	0.0%		0.0%	0.0%	0.0%	0.0%	0.0%	0.0%	0.0%		0.0%
Buses	0	1	1	0	2	0	0		1	10	1	0	12	0	0		0	2	1	0	3	0	0		3	11	1	0	15	0	0		32
% Buses	0.0%	14.3%	12.5%	0.0%	0.0%	0.0%	0.0%		4.3%	8.5%	25.0%	0.0%	0.0%	0.0%	0.0%		0.0%	9.1%	33.3%	0.0%	0.0%	0.0%	0.0%		60.0%	14.7%	20.0%	0.0%	0.0%	0.0%	0.0%		10.8%
Pedestrians	0	0	0	0	0	0	2		0	0	0	0	0	0	0		0	0	0	1	0	0	0	1	0	0	0	0	0	0	1	0	1
% Pedestrians	0.0%	0.0%	0.0%	0.0%	0.0%	0.0%	100.0%		0.0%	0.0%	0.0%	0.0%	0.0%	0.0%	0.0%		0.0%	0.0%	0.0%	0.0%	0.0%	0.0%	0.0%	100.0%	0.0%	0.0%	0.0%	0.0%	100.0%	0.0%			
Bicycles on Crosswalk	0	0	0	0	0	0	0		0	0	0	0	0	0	0		0	0	0	0	0	0	0	0	0	0	0	0	0	0	0	0	0
% Bicycles on Crosswalk	0.0%	0.0%	0.0%	0.0%	0.0%	0.0%	0.0%		0.0%	0.0%	0.0%	0.0%	0.0%	0.0%	0.0%		0.0%	0.0%	0.0%	0.0%	0.0%	0.0%	0.0%	0.0%	0.0%	0.0%	0.0%	0.0%	0.0%	0.0%	0.0%		0.0%

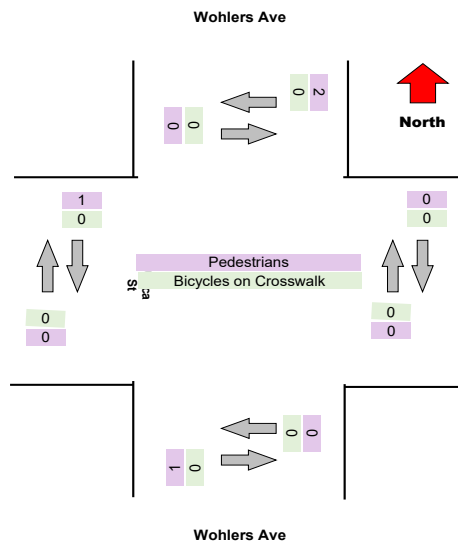
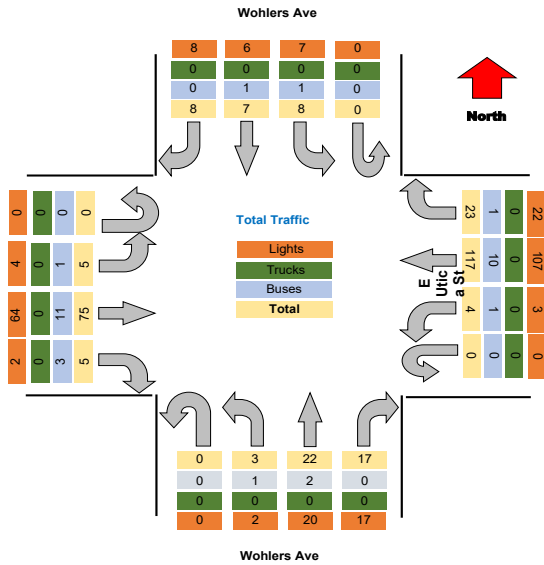

Project : VBH Malta NY
Site : Site 4
Location : 42.948550, -73.790036

TSTData.com

Survey Date : 2021-04-28, Wednesday

Turning Movement Peak Hour Data (PM)

4:15:00 PM

Leg Direction	Wohlers Ave								E Utica St								Wohlers Ave								E Utica St								Total
	Southbound				Westbound				Northbound				Eastbound				Northbound				Eastbound												
	Right	Thru	Left	U-Turn	App Total	Peds CW	Peds CCW		Right	Thru	Left	U-Turn	App Total	Peds CW	Peds CCW		Right	Thru	Left	U-Turn	App Total	Peds CW	Peds CCW		Right	Thru	Left	U-Turn	App Total	Peds CW	Peds CCW		
4:15:00 PM	2	9	1	0	12	4	1	4	39	3	0	46	1	0	0	0	0	5	13	3	0	21	0	0	0	0	0	0	0	0	0	0	121
4:30:00 PM	0	4	1	0	5	6	3	1	29	2	0	32	0	0	0	0	0	6	23	1	0	30	0	1	2	37	3	0	42	2	1	0	109
4:45:00 PM	0	5	2	0	7	3	2	7	42	3	0	52	0	0	0	0	0	5	10	3	0	18	0	0	1	39	6	0	46	3	0	0	123
5:00:00 PM	4	3	2	0	9	0	0	8	36	3	0	47	0	0	0	0	0	13	7	4	0	24	1	1	3	33	2	0	38	2	0	0	118
Grand Total	6	21	6	0	33	13	6	20	146	11	0	177	1	0	0	0	0	29	53	11	0	93	1	2	9	147	12	0	168	7	2	0	471
% Approach	18.2%	63.6%	18.2%	0.0%	0.0%	0.0%	0.0%	11.3%	82.5%	6.2%	0.0%	0.6%	0.0%	0.0%	0.0%	0.0%	0.0%	31.2%	57.0%	11.8%	0.0%	0.0%	0.0%	0.0%	5.4%	87.5%	7.1%	0.0%	0.0%	0.0%	0.0%	0.0%	
% Total	1.3%	4.5%	1.3%	0.0%	7.0%	0.0%	0.0%	4.2%	31.0%	2.3%	0.0%	37.6%	0.0%	0.0%	0.0%	0.0%	0.0%	6.2%	11.3%	2.3%	0.0%	19.7%	0.0%	0.0%	1.9%	31.2%	2.5%	0.0%	35.7%	0.0%	0.0%	0.0%	
PHF	0.375	0.583	0.750	0.000	0.688	0.000	0.000	0.625	0.889	0.917	0.000	0.851	0.000	0.000	0.000	0.000	0.000	0.558	0.576	0.688	0.000	0.775	0.000	0.000	0.750	0.842	0.500	0.000	0.913	0.000	0.000	0.000	
Lights	4	18	4	0	26	0	0	19	141	9	0	169	0	0	0	0	0	29	52	9	0	90	0	0	8	142	12	0	162	0	0	0	447
% Lights	66.7%	85.7%	66.7%	0.0%	78.8%	0.0%	0.0%	95.0%	96.6%	81.8%	0.0%	95.5%	0.0%	0.0%	0.0%	0.0%	0.0%	100.0%	98.1%	81.8%	0.0%	96.8%	0.0%	0.0%	88.9%	96.6%	100.0%	0.0%	96.4%	0.0%	0.0%	0.0%	
Trucks	0	0	0	0	0	0	0	0	0	0	0	0	0	0	0	0	0	0	0	0	0	0	0	0	0	0	0	0	0	0	0	0	0
% Trucks	0.0%	0.0%	0.0%	0.0%	0.0%	0.0%	0.0%	0.0%	0.0%	0.0%	0.0%	0.0%	0.0%	0.0%	0.0%	0.0%	0.0%	0.0%	0.0%	0.0%	0.0%	0.0%	0.0%	0.0%	0.0%	0.0%	0.0%	0.0%	0.0%	0.0%	0.0%	0.0%	
Buses	2	3	2	0	7	0	0	1	5	2	0	8	0	0	0	0	0	0	1	2	0	3	0	0	0	5	0	0	5	0	0	0	23
% Buses	33.3%	14.3%	33.3%	0.0%	0.0%	0.0%	0.0%	5.0%	3.4%	18.2%	0.0%	0.0%	0.0%	0.0%	0.0%	0.0%	0.0%	0.0%	1.9%	18.2%	0.0%	0.0%	0.0%	0.0%	0.0%	3.4%	0.0%	0.0%	0.0%	0.0%	0.0%	0.0%	
Pedestrians	0	0	0	0	0	13	6	0	0	0	0	0	1	0	0	0	0	0	0	0	0	1	2	0	0	0	0	0	0	7	2	0	
% Pedestrians	0.0%	0.0%	0.0%	0.0%	0.0%	100.0%	100.0%	0.0%	0.0%	0.0%	0.0%	0.0%	100.0%	0.0%	0.0%	0.0%	0.0%	0.0%	0.0%	0.0%	0.0%	0.0%	100.0%	100.0%	0.0%	0.0%	0.0%	0.0%	0.0%	100.0%	100.0%	0.0%	
Bicycles on Crosswalk	0	0	0	0	0	0	0	0	0	0	0	0	0	0	0	0	0	0	0	0	0	0	0	0	0	0	0	0	0	0	0	0	0
% Bicycles on Crosswalk	0.0%	0.0%	0.0%	0.0%	0.0%	0.0%	0.0%	0.0%	0.0%	0.0%	0.0%	0.0%	0.0%	0.0%	0.0%	0.0%	0.0%	0.0%	0.0%	0.0%	0.0%	0.0%	0.0%	0.0%	0.0%	0.0%	0.0%	0.0%	0.0%	0.0%	0.0%	0.0%	

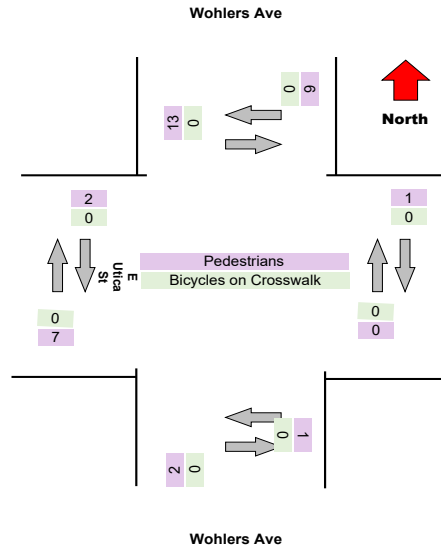
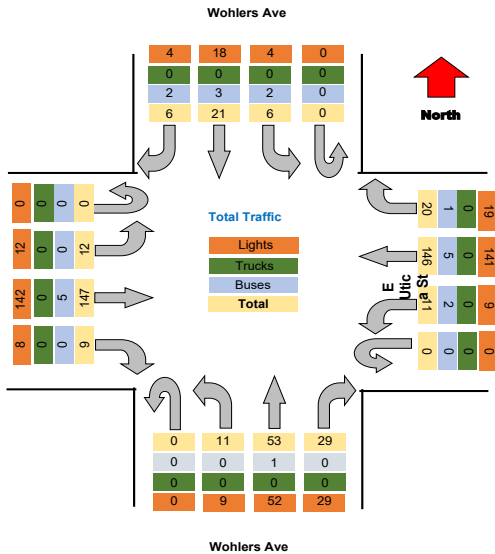

Intersection: Elm St Pine St
 Location: Kennett Square, PA
 Site: 01
 Survey Date: Wednesday, 04-28-2021
 GPS: 42.948550, -72.790034



TSTData.com

Project	Labella
Project Code	Labella
Site Name	A
Legs and Movements	All Processed Legs & Movement
Bin Size	15 minutes
Survey Date	2021-10-26, Tuesday
Location	A
Latitude and Longitude	42.913814, -78.843710

	Start	End	PHF
Forced Peak AM	2021/10/26 07:30:00	2021/10/26 08:30:00	0.862
Forced Peak PM	2021/10/26 16:30:00	2021/10/26 17:30:00	0.925
AM Peak	2021/10/26 07:30:00	2021/10/26 08:30:00	0.862
PM Peak	2021/10/26 16:15:00	2021/10/26 17:15:00	0.962

Turning Movement Data

Leg Direction	Humboldt Pkwy Southbound						Humboldt Pkwy Northbound						Woodlawn Ave Eastbound						Total
	Right	Thru	U-Turn	App Total	Peds CW	Peds CCW	Thru	Left	U-Turn	App Total	Peds CW	Peds CCW	Right	Left	U-Turn	App Total	Peds CW	Peds CCW	
Start Time																			
6:30:00 AM	2	36	0	38	0	0	0	0	0	0	0	0	0	0	0	0	0	0	3
6:45:00 AM	2	54	0	56	0	0	0	0	0	0	0	0	0	0	0	0	2	0	2
Hourly Total	4	90	0	94	0	0	0	0	0	0	0	0	0	0	0	0	2	3	94
7:00:00 AM	6	45	0	51	0	0	0	0	0	0	0	0	0	0	0	0	1	0	1
7:15:00 AM	6	57	0	63	1	0	0	0	0	0	0	0	0	0	0	0	1	0	1
7:30:00 AM	9	91	0	100	0	0	0	0	0	0	0	0	0	0	0	0	2	2	4
7:45:00 AM	7	83	0	90	0	0	0	0	0	0	0	0	0	0	0	0	3	2	5
Hourly Total	28	276	0	304	1	0	0	0	0	0	0	0	0	0	0	0	7	4	304
8:00:00 AM	3	74	0	77	0	0	0	0	0	0	0	0	0	0	0	0	0	0	0
8:15:00 AM	11	98	0	109	0	0	0	0	0	0	0	0	0	0	0	0	0	1	1
Hourly Total	14	172	0	186	0	0	0	0	0	0	0	0	0	0	0	0	0	1	186
4:00:00 PM	6	160	0	166	0	0	0	0	0	0	0	0	0	0	0	0	0	2	2
4:15:00 PM	7	116	0	123	0	0	0	0	0	0	0	0	0	0	0	0	1	0	1
4:30:00 PM	8	122	0	130	0	2	0	0	0	0	0	0	0	0	0	0	0	3	3
4:45:00 PM	15	112	0	127	0	0	0	0	0	0	0	0	0	0	0	0	0	0	0
Hourly Total	36	510	0	546	0	2	0	0	0	0	0	0	0	0	0	0	1	5	546
5:00:00 PM	15	105	0	120	0	0	0	0	0	0	0	0	0	0	0	0	0	1	1
5:15:00 PM	8	96	0	104	0	0	0	0	0	0	0	0	0	0	0	0	1	3	4
5:30:00 PM	12	88	0	100	0	0	0	0	0	0	0	0	0	0	0	0	0	0	0
5:45:00 PM	10	81	0	91	0	0	0	0	0	0	0	0	0	0	0	0	0	0	0
Hourly Total	45	370	0	415	0	0	0	0	0	0	0	0	0	0	0	0	1	4	415
Grand Total	127	1418	0	1545	1	2	0	0	0	0	0	0	0	0	0	0	11	17	1545
% Approach	8.2%	91.8%	0.0%	0.0%	0.0%	0.0%	0.0%	0.0%	0.0%	0.0%	0.0%	0.0%	0.0%	0.0%	0.0%	0.0%	0.0%	0.0%	0.0%
% Total	8.2%	91.8%	0.0%	100.0%	0.0%	0.0%	0.0%	0.0%	0.0%	0.0%	0.0%	0.0%	0.0%	0.0%	0.0%	0.0%	0.0%	0.0%	0.0%
Lights	118	1365	0	1483	0	0	0	0	0	0	0	0	0	0	0	0	0	0	0
% Lights	92.9%	96.3%	0.0%	96.0%	0.0%	0.0%	0.0%	0.0%	0.0%	0.0%	0.0%	0.0%	0.0%	0.0%	0.0%	0.0%	0.0%	0.0%	0.0%
Trucks	0	0	0	0	0	0	0	0	0	0	0	0	0	0	0	0	0	0	0
% Trucks	0.0%	0.0%	0.0%	0.0%	0.0%	0.0%	0.0%	0.0%	0.0%	0.0%	0.0%	0.0%	0.0%	0.0%	0.0%	0.0%	0.0%	0.0%	0.0%
Buses	9	53	0	62	0	0	0	0	0	0	0	0	0	0	0	0	0	0	0
% Buses	7.1%	3.7%	0.0%	0.0%	0.0%	0.0%	0.0%	0.0%	0.0%	0.0%	0.0%	0.0%	0.0%	0.0%	0.0%	0.0%	0.0%	0.0%	0.0%
Pedestrians	0	0	0	0	1	2	0	0	0	0	0	0	0	0	0	0	10	17	27
% Pedestrians	0.0%	0.0%	0.0%	0.0%	100.0%	100.0%	0.0%	0.0%	0.0%	0.0%	0.0%	0.0%	0.0%	0.0%	0.0%	0.0%	90.9%	100.0%	100.0%
% Bicycles on Crosswalk	0.0%	0.0%	0.0%	0.0%	0.0%	0.0%	0.0%	0.0%	0.0%	0.0%	0.0%	0.0%	0.0%	0.0%	0.0%	0.0%	9.1%	0.0%	0.0%

Turning Movement Data Plot

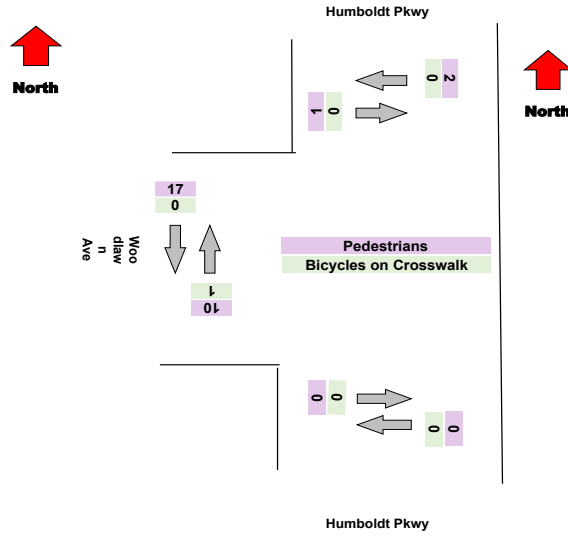
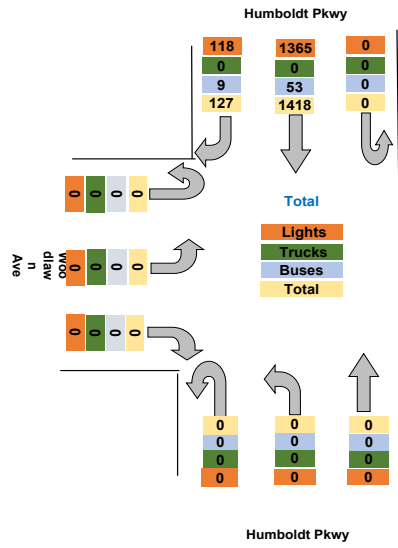

Turning Movement Peak Hour Data (AM)

7:30:00 AM

Leg Direction	Humboldt Pkwy Southbound						Humboldt Pkwy NorthBound						Woodlawn Ave Eastbound						Total
	Right	Thru	U-Turn	App Total	Peds CW	Peds CCW	Thru	Left	U-Turn	App Total	Peds CW	Peds CCW	Right	Left	U-Turn	App Total	Peds CW	Peds CCW	
7:30:00 AM	9	91	0	100	0	0	0	0	0	0	0	0	0	0	0	0	2	2	100
7:45:00 AM	7	83	0	90	0	0	0	0	0	0	0	0	0	0	0	3	2	90	
8:00:00 AM	3	74	0	77	0	0	0	0	0	0	0	0	0	0	0	0	0	77	
8:15:00 AM	11	98	0	109	0	0	0	0	0	0	0	0	0	0	0	0	1	109	
Grand Total	30	346	0	376	0	0	0	0	0	0	0	0	0	0	0	5	5	376	
% Approach	8.0%	92.0%	0.0%	0.0%	0.0%	0.0%	14.2%	0.0%	0.0%	0.0%	0.0%	0.0%	45.1%	41.7%	0.0%	0.0%	0.0%	0.0%	
% Total	8.0%	92.0%	0.0%	100.0%	0.0%	0.0%	0.0%	0.0%	0.0%	0.0%	0.0%	0.0%	0.0%	0.0%	0.0%	0.0%	0.0%	0.0%	
PHF	0.682	0.883	0.000	0.862	0.000	0.000	0.000	0.000	0.000	0.000	0.000	0.000	0.000	0.000	0.000	0.000	0.000	0.000	
Lights	26	331	0	357	0	0	0	0	0	0	0	0	0	0	0	0	0	357	
% Lights	86.7%	95.7%	0.0%	94.9%	0.0%	0.0%	0.0%	0.0%	0.0%	0.0%	0.0%	0.0%	0.0%	0.0%	0.0%	0.0%	0.0%	94.9%	
Trucks	0	0	0	0	0	0	0	0	0	0	0	0	0	0	0	0	0	0	
% Trucks	0.0%	0.0%	0.0%	0.0%	0.0%	0.0%	0.0%	0.0%	0.0%	0.0%	0.0%	0.0%	0.0%	0.0%	0.0%	0.0%	0.0%	0.0%	
Buses	4	15	0	19	0	0	0	0	0	0	0	0	0	0	0	0	0	19	
% Buses	13.3%	4.3%	0.0%	0.0%	0.0%	0.0%	0.0%	0.0%	0.0%	0.0%	0.0%	0.0%	0.0%	0.0%	0.0%	0.0%	0.0%	5.1%	
Pedestrians	0	0	0	0	0	0	0	0	0	0	0	0	0	0	0	4	5	0	
% Pedestrians	0.0%	0.0%	0.0%	0.0%	0.0%	0.0%	0.0%	0.0%	0.0%	0.0%	0.0%	0.0%	0.0%	0.0%	0.0%	80.0%	100.0%	0.0%	
Bicycles on Crosswalk	0	0	0	0	0	0	0	0	0	0	0	0	0	0	0	1	0	0	
% Bicycles on Crosswalk	0.0%	0.0%	0.0%	0.0%	0.0%	0.0%	0.0%	0.0%	0.0%	0.0%	0.0%	0.0%	0.0%	0.0%	0.0%	20.0%	0.0%	0.0%	

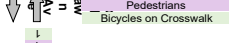
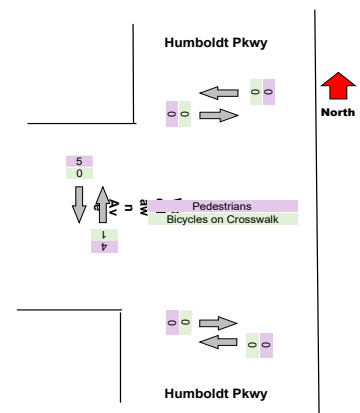
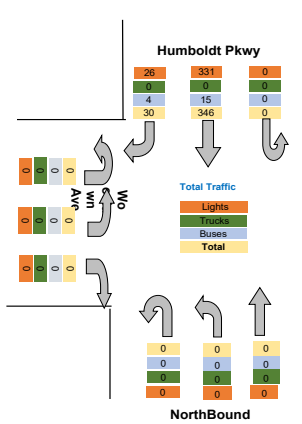

Turning Movement Peak Hour Data (PM)

4:15:00 PM

Leg Direction	Humboldt Pkwy Southbound						Humboldt Pkwy NorthBound						Woodlawn Ave Eastbound						Total
	Right	Thru	U-Turn	App Total	Peds CW	Peds CCW	Thru	Left	U-Turn	App Total	Peds CW	Peds CCW	Right	Left	U-Turn	App Total	Peds CW	Peds CCW	
4:15:00 PM	7	116	0	123	0	0	0	0	0	0	0	0	0	0	0	0	1	0	123
4:30:00 PM	8	122	0	130	0	2	0	0	0	0	0	0	0	0	0	0	0	3	130
4:45:00 PM	15	112	0	127	0	0	0	0	0	0	0	0	0	0	0	0	0	0	127
5:00:00 PM	15	105	0	120	0	0	0	0	0	0	0	0	0	0	0	0	0	1	120
Grand Total	45	455	0	500	0	2	0	0	0	0	0	0	0	0	0	0	1	4	500
% Approach	9.0%	91.0%	0.0%	0.0%	0.0%	0.0%	14.2%	0.0%	0.0%	0.0%	0.0%	0.0%	45.1%	41.7%	0.0%	0.0%	0.0%	0.0%	0.0%
% Total	9.0%	91.0%	0.0%	100.0%	0.0%	0.0%	0.0%	0.0%	0.0%	0.0%	0.0%	0.0%	0.0%	0.0%	0.0%	0.0%	0.0%	0.0%	0.0%
PHF	0.750	0.932	0.000	0.962	0.000	0.000	0.000	0.000	0.000	0.000	0.000	0.000	0.000	0.000	0.000	0.000	0.000	0.000	0.962
Lights	42	434	0	476	0	0	0	0	0	0	0	0	0	0	0	0	0	0	476
% Lights	93.3%	95.4%	0.0%	95.2%	0.0%	0.0%	0.0%	0.0%	0.0%	0.0%	0.0%	0.0%	0.0%	0.0%	0.0%	0.0%	0.0%	0.0%	95.2%
Trucks	0	0	0	0	0	0	0	0	0	0	0	0	0	0	0	0	0	0	0
% Trucks	0.0%	0.0%	0.0%	0.0%	0.0%	0.0%	0.0%	0.0%	0.0%	0.0%	0.0%	0.0%	0.0%	0.0%	0.0%	0.0%	0.0%	0.0%	0.0%
Buses	3	21	0	24	0	0	0	0	0	0	0	0	0	0	0	0	0	0	24
% Buses	6.7%	4.6%	0.0%	0.0%	0.0%	0.0%	0.0%	0.0%	0.0%	0.0%	0.0%	0.0%	0.0%	0.0%	0.0%	0.0%	0.0%	0.0%	4.8%
Pedestrians	0	0	0	0	0	2	0	0	0	0	0	0	0	0	0	0	1	4	0
% Pedestrians	0.0%	0.0%	0.0%	0.0%	0.0%	100.0%	0.0%	0.0%	0.0%	0.0%	0.0%	0.0%	0.0%	0.0%	0.0%	0.0%	100.0%	100.0%	0.0%
Bicycles on Crosswalk	0	0	0	0	0	0	0	0	0	0	0	0	0	0	0	0	0	0	0
% Bicycles on Crosswalk	0.0%	0.0%	0.0%	0.0%	0.0%	0.0%	0.0%	0.0%	0.0%	0.0%	0.0%	0.0%	0.0%	0.0%	0.0%	0.0%	0.0%	0.0%	0.0%

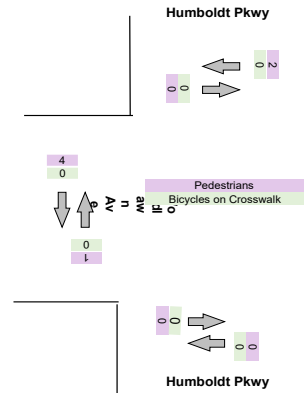
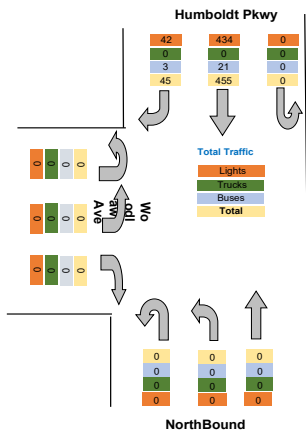

Intersection: Elm St Pine St
 Location: Kennett Square, PA
 Site: 01
 Survey Date: Wednesday, 04-28-2021
 GPS: 42.948550, -72.790034



TSTData.com

Project	Labella
Project Code	Labella
Site Name	A
Legs and Movements	All Processed Legs & Movement
Bin Size	15 minutes
Survey Date	2021-10-27, Wednesday
Location	A
Latitude and Longitude	42.913814, -78.843710

	Start	End	PHF
Forced Peak AM	2021/10/27 07:30:00	2021/10/27 08:30:00	0.862
Forced Peak PM	2021/10/27 16:30:00	2021/10/27 17:30:00	0.878
AM Peak	2021/10/27 07:30:00	2021/10/27 08:30:00	0.862
PM Peak	2021/10/27 16:15:00	2021/10/27 17:15:00	0.865

Turning Movement Data

Leg Direction	Humboldt Pkwy Southbound						Humboldt Pkwy Northbound						Woodlawn Ave Eastbound						Total	
	Right	Thru	U-Turn	App Total	Peds CW	Peds CCW	Thru	Left	U-Turn	App Total	Peds CW	Peds CCW	Right	Left	U-Turn	App Total	Peds CW	Peds CCW		
6:30:00 AM	1	40	0	41	0	0	0	0	0	0	0	0	0	0	0	0	0	0	3	41
6:45:00 AM	2	49	0	51	0	0	0	0	0	0	0	0	0	0	0	0	1	0	0	51
Hourly Total	3	89	0	92	0	0	0	0	0	0	0	0	0	0	0	1	0	0	3	92
7:00:00 AM	5	38	0	43	0	0	0	0	0	0	0	0	0	0	0	0	1	0	0	43
7:15:00 AM	7	60	0	67	0	0	0	0	0	0	0	0	0	0	0	0	1	0	0	67
7:30:00 AM	9	74	0	83	0	0	0	0	0	0	0	0	0	0	0	0	0	0	0	83
7:45:00 AM	10	108	0	118	0	0	0	0	0	0	0	0	0	0	0	0	2	1	0	118
Hourly Total	31	280	0	311	0	0	0	0	0	0	0	0	0	0	0	4	1	0	311	311
8:00:00 AM	6	95	0	101	0	0	0	0	0	0	0	0	0	0	0	0	0	1	0	101
8:15:00 AM	9	96	0	105	0	0	0	0	0	0	0	0	0	0	0	0	1	0	0	105
Hourly Total	15	191	0	206	0	0	0	0	0	0	0	0	0	0	0	0	1	1	0	206
4:00:00 PM	10	113	0	123	0	0	0	0	0	0	0	0	0	0	0	0	1	0	0	123
4:15:00 PM	15	103	0	118	0	0	0	0	0	0	0	0	0	0	0	0	0	0	0	118
4:30:00 PM	13	120	0	133	0	0	0	0	0	0	0	0	0	0	0	0	1	0	0	133
4:45:00 PM	11	92	0	103	0	0	0	0	0	0	0	0	0	0	0	0	0	2	0	103
Hourly Total	49	428	0	477	0	0	0	0	0	0	0	0	0	0	0	2	2	0	477	477
5:00:00 PM	6	100	0	106	0	0	0	0	0	0	0	0	0	0	0	0	1	1	0	106
5:15:00 PM	13	112	0	125	0	0	0	0	0	0	0	0	0	0	0	0	1	1	0	125
5:30:00 PM	11	93	0	104	0	0	0	0	0	0	0	0	0	0	0	0	0	1	0	104
5:45:00 PM	11	86	0	97	0	0	0	0	0	0	0	0	0	0	0	0	0	0	0	97
Hourly Total	41	391	0	432	0	0	0	0	0	0	0	0	0	0	0	2	3	0	432	432
Grand Total	139	1379	0	1518	0	0	0	0	0	0	0	0	0	0	0	10	10	0	1518	1518
% Approach	9.2%	90.8%	0.0%	0.0%	0.0%	0.0%	0.0%	0.0%	0.0%	0.0%	0.0%	0.0%	0.0%	0.0%	0.0%	0.0%	0.0%	0.0%	0.0%	0.0%
% Total	9.2%	90.8%	0.0%	100.0%	0.0%	0.0%	0.0%	0.0%	0.0%	0.0%	0.0%	0.0%	0.0%	0.0%	0.0%	0.0%	0.0%	0.0%	0.0%	0.0%
Lights	125	1326	0	1451	0	0	0	0	0	0	0	0	0	0	0	0	0	0	0	1451
% Lights	89.9%	96.2%	0.0%	95.6%	0.0%	0.0%	0.0%	0.0%	0.0%	0.0%	0.0%	0.0%	0.0%	0.0%	0.0%	0.0%	0.0%	0.0%	0.0%	95.6%
Trucks	0	0	0	0	0	0	0	0	0	0	0	0	0	0	0	0	0	0	0	0
% Trucks	0.0%	0.0%	0.0%	0.0%	0.0%	0.0%	0.0%	0.0%	0.0%	0.0%	0.0%	0.0%	0.0%	0.0%	0.0%	0.0%	0.0%	0.0%	0.0%	0.0%
Buses	13	52	0	65	0	0	0	0	0	0	0	0	0	0	0	0	0	0	0	65
% Buses	9.4%	3.8%	0.0%	0.0%	0.0%	0.0%	0.0%	0.0%	0.0%	0.0%	0.0%	0.0%	0.0%	0.0%	0.0%	0.0%	0.0%	0.0%	0.0%	4.3%
Pedestrians	0	0	0	0	0	0	0	0	0	0	0	0	0	0	0	9	10	0	0	0
% Pedestrians	0.0%	0.0%	0.0%	0.0%	0.0%	0.0%	0.0%	0.0%	0.0%	0.0%	0.0%	0.0%	0.0%	0.0%	0.0%	90.0%	100.0%	0.0%	0.0%	0.0%
% Bicycles on Crosswalk	0.0%	0.0%	0.0%	0.0%	0.0%	0.0%	0.0%	0.0%	0.0%	0.0%	0.0%	0.0%	0.0%	0.0%	0.0%	10.0%	0.0%	0.0%	0.0%	0.0%

Turning Movement Data Plot

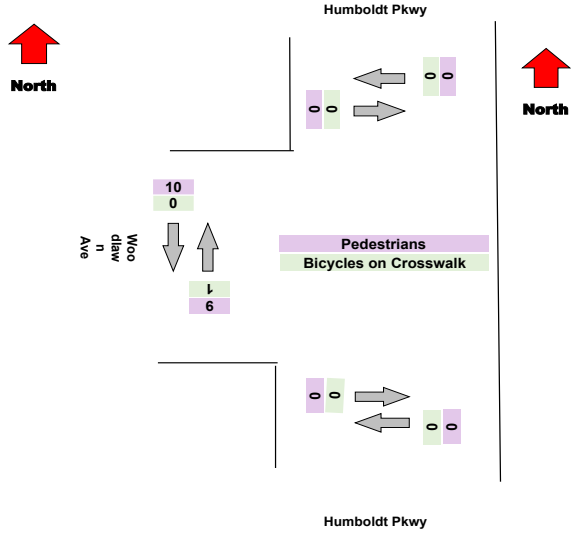
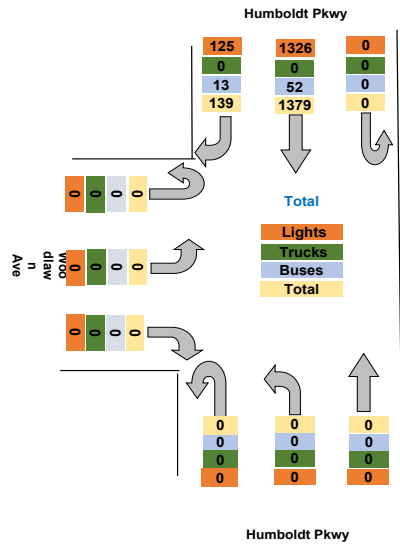

Turning Movement Peak Hour Data (AM)

7:30:00 AM

Leg Direction	Humboldt Pkwy Southbound						Humboldt Pkwy NorthBound						Woodlawn Ave Eastbound						Total	
	Right	Thru	U-Turn	App Total	Peds CW	Peds CCW	Thru	Left	U-Turn	App Total	Peds CW	Peds CCW	Right	Left	U-Turn	App Total	Peds CW	Peds CCW		
7:30:00 AM	9	74	0	83	0	0	0	0	0	0	0	0	0	0	0	0	0	0	0	83
7:45:00 AM	10	108	0	118	0	0	0	0	0	0	0	0	0	0	0	0	2	0	1	118
8:00:00 AM	6	95	0	101	0	0	0	0	0	0	0	0	0	0	0	0	0	1	0	101
8:15:00 AM	9	96	0	105	0	0	0	0	0	0	0	0	0	0	0	1	0	0	0	105
Grand Total	34	373	0	407	0	0	0	0	0	0	0	0	0	0	0	3	2	0	0	407
% Approach	8.4%	91.6%	0.0%	0.0%	0.0%	0.0%	14.2%	0.0%	0.0%	0.0%	0.0%	0.0%	45.1%	41.7%	0.0%	0.0%	0.0%	0.0%	0.0%	0.0%
% Total	8.4%	91.6%	0.0%	100.0%	0.0%	0.0%	0.0%	0.0%	0.0%	0.0%	0.0%	0.0%	0.0%	0.0%	0.0%	0.0%	0.0%	0.0%	0.0%	0.0%
PHF	0.850	0.863	0.000	0.862	0.000	0.000	0.000	0.000	0.000	0.000	0.000	0.000	0.000	0.000	0.000	0.000	0.000	0.000	0.000	0.862
Lights	30	353	0	383	0	0	0	0	0	0	0	0	0	0	0	0	0	0	0	383
% Lights	88.2%	94.6%	0.0%	94.1%	0.0%	0.0%	0.0%	0.0%	0.0%	0.0%	0.0%	0.0%	0.0%	0.0%	0.0%	0.0%	0.0%	0.0%	0.0%	94.1%
Trucks	0	0	0	0	0	0	0	0	0	0	0	0	0	0	0	0	0	0	0	0
% Trucks	0.0%	0.0%	0.0%	0.0%	0.0%	0.0%	0.0%	0.0%	0.0%	0.0%	0.0%	0.0%	0.0%	0.0%	0.0%	0.0%	0.0%	0.0%	0.0%	0.0%
Buses	4	20	0	24	0	0	0	0	0	0	0	0	0	0	0	0	0	0	0	24
% Buses	11.8%	5.4%	0.0%	0.0%	0.0%	0.0%	0.0%	0.0%	0.0%	0.0%	0.0%	0.0%	0.0%	0.0%	0.0%	0.0%	0.0%	0.0%	0.0%	5.9%
Pedestrians	0	0	0	0	0	0	0	0	0	0	0	0	0	0	0	0	3	2	0	0
% Pedestrians	0.0%	0.0%	0.0%	0.0%	0.0%	0.0%	0.0%	0.0%	0.0%	0.0%	0.0%	0.0%	0.0%	0.0%	0.0%	0.0%	100.0%	100.0%	0.0%	0.0%
Bicycles on Crosswalk	0	0	0	0	0	0	0	0	0	0	0	0	0	0	0	0	0	0	0	0
% Bicycles on Crosswalk	0.0%	0.0%	0.0%	0.0%	0.0%	0.0%	0.0%	0.0%	0.0%	0.0%	0.0%	0.0%	0.0%	0.0%	0.0%	0.0%	0.0%	0.0%	0.0%	0.0%

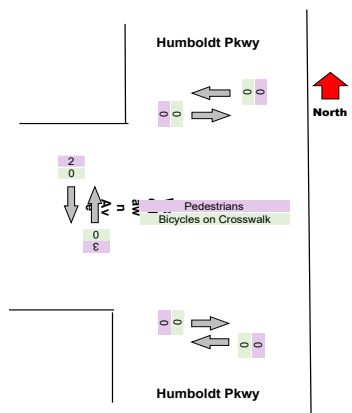
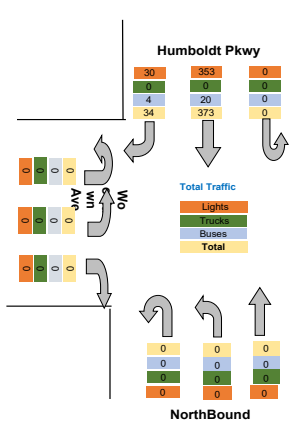

Turning Movement Peak Hour Data (PM)

4:15:00 PM

Leg Direction	Humboldt Pkwy Southbound						Humboldt Pkwy NorthBound						Woodlawn Ave Eastbound						Total
	Right	Thru	U-Turn	App Total	Peds CW	Peds CCW	Thru	Left	U-Turn	App Total	Peds CW	Peds CCW	Right	Left	U-Turn	App Total	Peds CW	Peds CCW	
4:15:00 PM	15	103	0	118	0	0	0	0	0	0	0	0	0	0	0	0	0	0	118
4:30:00 PM	13	120	0	133	0	0	0	0	0	0	0	0	0	0	0	0	1	0	133
4:45:00 PM	11	92	0	103	0	0	0	0	0	0	0	0	0	0	0	0	0	2	103
5:00:00 PM	6	100	0	106	0	0	0	0	0	0	0	0	0	0	0	0	1	1	106
Grand Total	45	415	0	460	0	0	0	0	0	0	0	0	0	0	0	0	2	3	460
% Approach	9.8%	90.2%	0.0%	0.0%	0.0%	0.0%	14.2%	0.0%	0.0%	0.0%	0.0%	0.0%	45.1%	41.7%	0.0%	0.0%	0.0%	0.0%	0.0%
% Total	9.8%	90.2%	0.0%	100.0%	0.0%	0.0%	0.0%	0.0%	0.0%	0.0%	0.0%	0.0%	0.0%	0.0%	0.0%	0.0%	0.0%	0.0%	0.0%
PHF	0.750	0.865	0.000	0.865	0.000	0.000	0.000	0.000	0.000	0.000	0.000	0.000	0.000	0.000	0.000	0.000	0.000	0.000	0.865
Lights	43	399	0	442	0	0	0	0	0	0	0	0	0	0	0	0	0	0	442
% Lights	95.6%	96.1%	0.0%	96.1%	0.0%	0.0%	0.0%	0.0%	0.0%	0.0%	0.0%	0.0%	0.0%	0.0%	0.0%	0.0%	0.0%	0.0%	96.1%
Trucks	0	0	0	0	0	0	0	0	0	0	0	0	0	0	0	0	0	0	0
% Trucks	0.0%	0.0%	0.0%	0.0%	0.0%	0.0%	0.0%	0.0%	0.0%	0.0%	0.0%	0.0%	0.0%	0.0%	0.0%	0.0%	0.0%	0.0%	0.0%
Buses	2	15	0	17	0	0	0	0	0	0	0	0	0	0	0	0	0	0	17
% Buses	4.4%	3.6%	0.0%	0.0%	0.0%	0.0%	0.0%	0.0%	0.0%	0.0%	0.0%	0.0%	0.0%	0.0%	0.0%	0.0%	0.0%	0.0%	3.7%
Pedestrians	0	0	0	0	0	0	0	0	0	0	0	0	0	0	0	0	2	3	0
% Pedestrians	0.0%	0.0%	0.0%	0.0%	0.0%	0.0%	0.0%	0.0%	0.0%	0.0%	0.0%	0.0%	0.0%	0.0%	0.0%	0.0%	100.0%	100.0%	0.0%
Bicycles on Crosswalk	0	0	0	0	0	0	0	0	0	0	0	0	0	0	0	0	0	0	0
% Bicycles on Crosswalk	0.0%	0.0%	0.0%	0.0%	0.0%	0.0%	0.0%	0.0%	0.0%	0.0%	0.0%	0.0%	0.0%	0.0%	0.0%	0.0%	0.0%	0.0%	0.0%

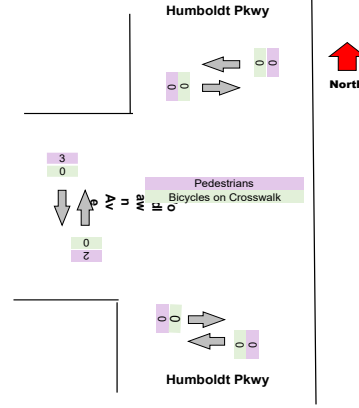
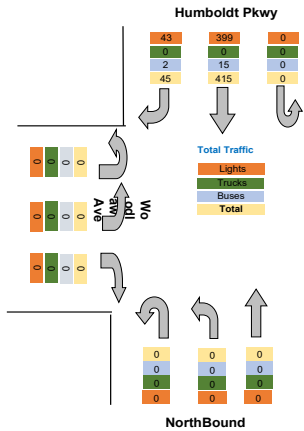

Turning Movement Data Plot

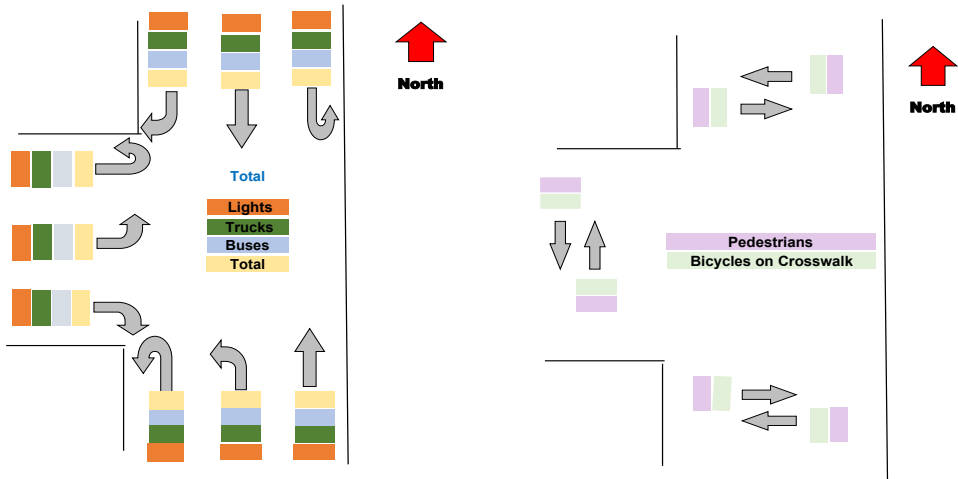

Turning Movement Peak Hour Data (AM)

7:30:00 AM

Leg Direction	Humboldt Pkwy Southbound						Humboldt Pkwy Northbound						Woodlawn Ave Eastbound						Total
	Right	Thru	U-Turn	App Total	Peds CW	Peds CCW	Thru	Left	U-Turn	App Total	Peds CW	Peds CCW	Right	Left	U-Turn	App Total	Peds CW	Peds CCW	
7:30:00 AM	8	85	0	93	0	0	0	0	0	0	0	0	0	0	0	0	0	2	1
7:45:00 AM	7	126	0	133	0	0	0	0	0	0	0	0	0	0	0	0	2	2	
8:00:00 AM	7	99	0	106	0	0	0	0	0	0	0	1	0	0	1	1	1	1	
8:15:00 AM	11	97	0	108	0	0	0	0	0	0	0	0	0	0	0	0	0	0	
Grand Total	33	407	0	440	0	0	0	0	0	0	0	1	0	0	1	5	4		
% Approach	7.5%	92.5%	0.0%	0.0%	0.0%	0.0%	14.2%	0.0%	0.0%	0.0%	0.0%	45.1%	41.7%	0.0%	0.0%	0.0%	0.0%	0.0%	
% Total	7.5%	92.3%	0.0%	99.8%	0.0%	0.0%	0.0%	0.0%	0.0%	0.0%	0.0%	0.2%	0.0%	0.0%	0.2%	0.0%	0.0%	0.0%	
PHF	0.750	0.808	0.000	0.827	0.000	0.000	0.000	0.000	0.000	0.000	0.000	0.250	0.000	0.000	0.250	0.000	0.000	0.000	
Lights	28	391	0	419	0	0	0	0	0	0	0	1	0	0	1	0	0	0	
% Lights	84.8%	96.1%	0.0%	95.2%	0.0%	0.0%	0.0%	0.0%	0.0%	0.0%	0.0%	100.0%	0.0%	0.0%	100.0%	0.0%	0.0%	0.0%	
Trucks	0	1	0	1	0	0	0	0	0	0	0	0	0	0	0	0	0	0	
% Trucks	0.0%	0.2%	0.0%	0.2%	0.0%	0.0%	0.0%	0.0%	0.0%	0.0%	0.0%	0.0%	0.0%	0.0%	0.0%	0.0%	0.0%	0.0%	
Buses	5	15	0	20	0	0	0	0	0	0	0	0	0	0	0	0	0	0	
% Buses	15.2%	3.7%	0.0%	0.0%	0.0%	0.0%	0.0%	0.0%	0.0%	0.0%	0.0%	0.0%	0.0%	0.0%	0.0%	0.0%	0.0%	0.0%	
Pedestrians	0	0	0	0	0	0	0	0	0	0	0	0	0	0	0	5	4	0	
% Pedestrians	0.0%	0.0%	0.0%	0.0%	0.0%	0.0%	0.0%	0.0%	0.0%	0.0%	0.0%	0.0%	0.0%	0.0%	0.0%	100.0%	100.0%	0.0%	
Bicycles on Crosswalk	0	0	0	0	0	0	0	0	0	0	0	0	0	0	0	0	0	0	
% Bicycles on Crosswalk	0.0%	0.0%	0.0%	0.0%	0.0%	0.0%	0.0%	0.0%	0.0%	0.0%	0.0%	0.0%	0.0%	0.0%	0.0%	0.0%	0.0%	0.0%	

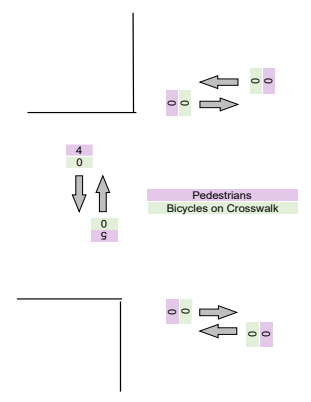
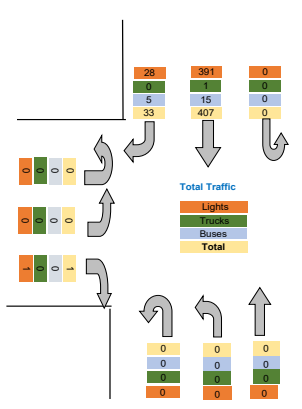

Turning Movement Peak Hour Data (PM)

4:15:00 PM

Leg Direction	Humboldt Pkwy Southbound						Humboldt Pkwy Northbound						Woodlawn Ave Eastbound						Total
	Right	Thru	U-Turn	App Total	Peds CW	Peds CCW	Thru	Left	U-Turn	App Total	Peds CW	Peds CCW	Right	Left	U-Turn	App Total	Peds CW	Peds CCW	
4:15:00 PM	13	136	0	149	0	0	0	0	0	0	0	0	0	0	0	0	0	1	149
4:30:00 PM	4	119	0	123	0	0	0	0	0	0	0	0	0	0	0	0	0	0	123
4:45:00 PM	14	118	0	132	0	0	0	0	0	0	0	0	0	0	0	1	0	0	132
5:00:00 PM	15	105	0	120	0	0	0	0	0	0	0	0	0	0	0	0	0	0	120
Grand Total	46	478	0	524	0	0	0	0	0	0	0	0	0	0	0	1	3	0	524
% Approach	8.8%	91.2%	0.0%	0.0%	0.0%	0.0%	14.2%	0.0%	0.0%	0.0%	0.0%	0.0%	45.1%	41.7%	0.0%	0.0%	0.0%	0.0%	0.0%
% Total	8.8%	91.2%	0.0%	100.0%	0.0%	0.0%	0.0%	0.0%	0.0%	0.0%	0.0%	0.0%	0.0%	0.0%	0.0%	0.0%	0.0%	0.0%	0.0%
PHF	0.767	0.879	0.000	0.879	0.000	0.000	0.000	0.000	0.000	0.000	0.000	0.000	0.000	0.000	0.000	0.000	0.000	0.000	0.879
Lights	43	460	0	503	0	0	0	0	0	0	0	0	0	0	0	0	0	0	503
% Lights	93.5%	96.2%	0.0%	96.0%	0.0%	0.0%	0.0%	0.0%	0.0%	0.0%	0.0%	0.0%	0.0%	0.0%	0.0%	0.0%	0.0%	0.0%	96.0%
Trucks	0	0	0	0	0	0	0	0	0	0	0	0	0	0	0	0	0	0	0
% Trucks	0.0%	0.0%	0.0%	0.0%	0.0%	0.0%	0.0%	0.0%	0.0%	0.0%	0.0%	0.0%	0.0%	0.0%	0.0%	0.0%	0.0%	0.0%	0.0%
Buses	3	17	0	20	0	0	0	0	0	0	0	0	0	0	0	0	0	0	20
% Buses	6.5%	3.6%	0.0%	0.0%	0.0%	0.0%	0.0%	0.0%	0.0%	0.0%	0.0%	0.0%	0.0%	0.0%	0.0%	0.0%	0.0%	0.0%	3.8%
Pedestrians	0	0	0	0	0	0	0	0	0	0	0	0	0	0	0	1	3	0	0
% Pedestrians	0.0%	0.0%	0.0%	0.0%	0.0%	0.0%	0.0%	0.0%	0.0%	0.0%	0.0%	0.0%	0.0%	0.0%	0.0%	0.0%	100.0%	100.0%	0.0%
Bicycles on Crosswalk	0	0	0	0	0	0	0	0	0	0	0	0	0	0	0	0	0	0	0
% Bicycles on Crosswalk	0.0%	0.0%	0.0%	0.0%	0.0%	0.0%	0.0%	0.0%	0.0%	0.0%	0.0%	0.0%	0.0%	0.0%	0.0%	0.0%	0.0%	0.0%	0.0%

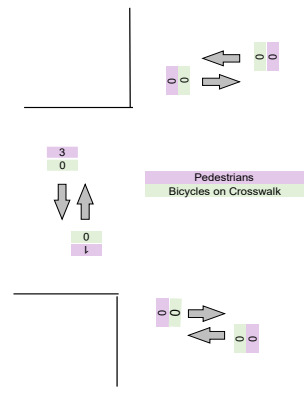
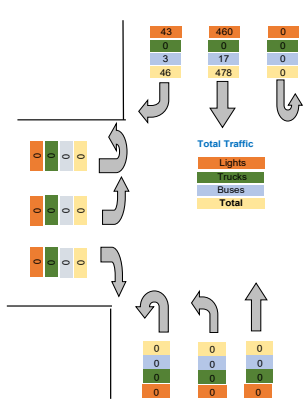

Project	Labella
Project Code	Labella
Site Name	B
Legs and Movements	All Processed Legs & Movements
Bin Size	15 minutes
Survey Date	2021-10-26, Tuesday
Location	B
Latitude and Longitude	42.912267, -78.843718

	Start	End	PHF
Forced Peak AM	2021/10/26 07:30:00	2021/10/26 08:30:00	0.862
Forced Peak PM	2021/10/26 16:30:00	2021/10/26 17:30:00	0.916
AM Peak	2021/10/26 07:30:00	2021/10/26 08:30:00	0.862
PM Peak	2021/10/26 16:15:00	2021/10/26 17:15:00	0.942

Turning Movement Data

Leg Direction	Humboldt Pkwy Southbound						Humboldt Pkwy NorthBound						Glenwood Ave Eastbound					
	Right	Thru	U-Turn	App Total	Peds	CCW	Thru	Left	U-Turn	App Total	Peds	CCW	Right	Left	U-Turn	App Total	Peds	CCW
Start Time																		
6:30:00 AM	0	34	0	34	0	0	0	0	0	0	0	0	6	0	0	6	1	0
6:45:00 AM	0	61	0	61	0	0	0	0	0	0	0	0	1	0	0	1	0	1
Hourly Total	0	95	0	95	0	0	0	0	0	0	0	0	7	0	0	7	1	1
7:00:00 AM	0	43	0	43	0	0	0	0	0	0	0	0	4	0	0	4	1	0
7:15:00 AM	0	57	0	57	0	0	0	0	0	0	0	0	2	0	0	2	0	1
7:30:00 AM	0	91	0	91	0	0	0	0	0	0	0	0	15	0	0	15	1	1
7:45:00 AM	0	89	0	89	0	0	0	0	0	0	0	0	10	0	0	10	1	2
Hourly Total	0	280	0	280	0	0	0	0	0	0	0	0	31	0	0	31	3	4
8:00:00 AM	0	78	0	78	0	0	0	0	0	0	0	0	1	0	0	1	0	0
8:15:00 AM	0	108	0	108	0	0	0	0	0	0	0	0	8	0	0	8	0	1
Hourly Total	0	186	0	186	0	0	0	0	0	0	0	0	9	0	0	9	0	1
4:00:00 PM	0	163	0	163	0	0	0	0	0	0	0	0	7	0	0	7	0	0
4:15:00 PM	0	108	0	108	0	0	0	0	0	0	0	0	5	0	0	5	0	0
4:30:00 PM	0	119	0	119	0	0	0	0	0	0	0	0	6	0	0	6	0	3
4:45:00 PM	0	112	0	112	0	0	0	0	0	0	0	0	4	0	0	4	0	0
Hourly Total	0	502	0	502	0	0	0	0	0	0	0	0	22	0	0	22	0	3
5:00:00 PM	0	109	0	109	0	0	0	0	0	0	0	0	8	0	0	8	0	1
5:15:00 PM	0	95	0	95	0	0	0	0	0	0	0	0	5	0	0	5	1	2
5:30:00 PM	0	91	0	91	0	0	0	0	0	0	0	0	4	0	0	4	0	0
5:45:00 PM	0	76	0	76	0	0	0	0	0	0	0	0	8	0	0	8	0	0
Hourly Total	0	371	0	371	0	0	0	0	0	0	0	0	25	0	0	25	1	3
Grand Total	0	1434	0	1434	0	0	0	0	0	0	0	0	94	0	0	94	5	12
% Approach	0.0%	100.0%	0.0%	0.0%	0.0%	0.0%	0.0%	0.0%	0.0%	0.0%	0.0%	0.0%	100.0%	0.0%	0.0%	0.0%	0.0%	0.0%
% Total	0.0%	93.8%	0.0%	93.8%	0.0%	0.0%	0.0%	0.0%	0.0%	0.0%	0.0%	0.0%	6.2%	0.0%	0.0%	6.2%	0.0%	0.0%
Lights	0	1382	0	1382	0	0	0	0	0	0	0	0	87	0	0	87	0	0
% Lights	0.0%	96.4%	0.0%	96.4%	0.0%	0.0%	0.0%	0.0%	0.0%	0.0%	0.0%	0.0%	92.6%	0.0%	0.0%	92.6%	0.0%	0.0%
Trucks	0	0	0	0	0	0	0	0	0	0	0	0	0	0	0	0	0	0
% Trucks	0.0%	0.0%	0.0%	0.0%	0.0%	0.0%	0.0%	0.0%	0.0%	0.0%	0.0%	0.0%	0.0%	0.0%	0.0%	0.0%	0.0%	0.0%
Buses	0	52	0	52	0	0	0	0	0	0	0	0	7	0	0	7	0	0
% Buses	0.0%	3.6%	0.0%	3.6%	0.0%	0.0%	0.0%	0.0%	0.0%	0.0%	0.0%	0.0%	7.4%	0.0%	0.0%	7.4%	0.0%	0.0%
Pedestrians	0	0	0	0	0	0	0	0	0	0	0	0	0	0	0	0	4	12
% Pedestrians	0.0%	0.0%	0.0%	0.0%	0.0%	0.0%	0.0%	0.0%	0.0%	0.0%	0.0%	0.0%	0.0%	0.0%	0.0%	0.0%	80.0%	100.0%
% Bicycles on Crosswalk	0.0%	0.0%	0.0%	0.0%	0.0%	0.0%	0.0%	0.0%	0.0%	0.0%	0.0%	0.0%	0.0%	0.0%	0.0%	0.0%	20.0%	0.0%

Turning Movement Data Plot

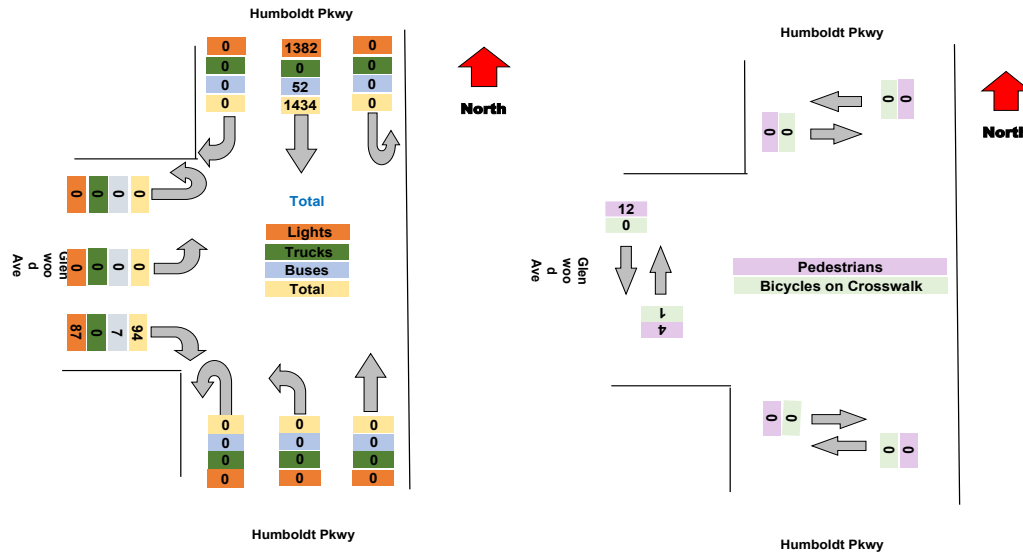

Turning Movement Peak Hour Data (AM)

7:30:00 AM

Leg Direction	Humboldt Pkwy Southbound						Humboldt Pkwy NorthBound						Glenwood Ave Eastbound					
	Right	Thru	U-Turn	App Total	Peds CW	Peds CCW	Thru	Left	U-Turn	App Total	Peds CW	Peds CCW	Right	Left	U-Turn	App Total	Peds CW	Peds CCW
7:30:00 AM	0	91	0	91	0	0	0	0	0	0	0	0	15	0	0	15	1	1
7:45:00 AM	0	89	0	89	0	0	0	0	0	0	0	0	10	0	0	10	1	2
8:00:00 AM	0	78	0	78	0	0	0	0	0	0	0	0	1	0	0	1	0	0
8:15:00 AM	0	108	0	108	0	0	0	0	0	0	0	0	8	0	0	8	0	1
Grand Total	0	366	0	366	0	0	0	0	0	0	0	0	34	0	0	34	2	4
% Approach	0.0%	100.0%	0.0%	0.0%	0.0%	0.0%	14.2%	0.0%	0.0%	0.0%	0.0%	0.0%	45.1%	41.7%	0.0%	0.0%	0.0%	0.0%
% Total	0.0%	91.5%	0.0%	91.5%	0.0%	0.0%	0.0%	0.0%	0.0%	0.0%	0.0%	0.0%	8.5%	0.0%	0.0%	8.5%	0.0%	0.0%
PHF	0.000	0.847	0.000	0.847	0.000	0.000	0.000	0.000	0.000	0.000	0.000	0.000	0.567	0.000	0.000	0.567	0.000	0.000
Lights	0	350	0	350	0	0	0	0	0	0	0	0	31	0	0	31	0	0
% Lights	0.0%	95.6%	0.0%	95.6%	0.0%	0.0%	0.0%	0.0%	0.0%	0.0%	0.0%	0.0%	91.2%	0.0%	0.0%	91.2%	0.0%	0.0%
Trucks	0	0	0	0	0	0	0	0	0	0	0	0	0	0	0	0	0	0
% Trucks	0.0%	0.0%	0.0%	0.0%	0.0%	0.0%	0.0%	0.0%	0.0%	0.0%	0.0%	0.0%	0.0%	0.0%	0.0%	0.0%	0.0%	0.0%
Buses	0	16	0	16	0	0	0	0	0	0	0	0	3	0	0	3	0	0
% Buses	0.0%	4.4%	0.0%	4.4%	0.0%	0.0%	0.0%	0.0%	0.0%	0.0%	0.0%	0.0%	8.8%	0.0%	0.0%	8.8%	0.0%	0.0%
Pedestrians	0	0	0	0	0	0	0	0	0	0	0	0	0	0	0	0	1	4
% Pedestrians	0.0%	0.0%	0.0%	0.0%	0.0%	0.0%	0.0%	0.0%	0.0%	0.0%	0.0%	0.0%	0.0%	0.0%	0.0%	0.0%	50.0%	100.0%
Bicycles on Crosswalk	0	0	0	0	0	0	0	0	0	0	0	0	0	0	0	0	1	0
% Bicycles on Crosswalk	0.0%	0.0%	0.0%	0.0%	0.0%	0.0%	0.0%	0.0%	0.0%	0.0%	0.0%	0.0%	0.0%	0.0%	0.0%	0.0%	50.0%	0.0%

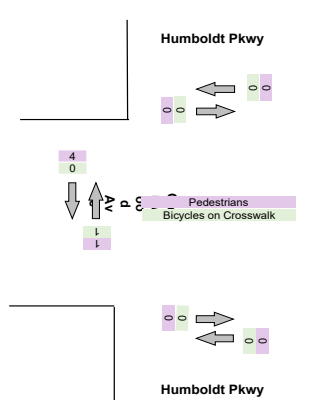
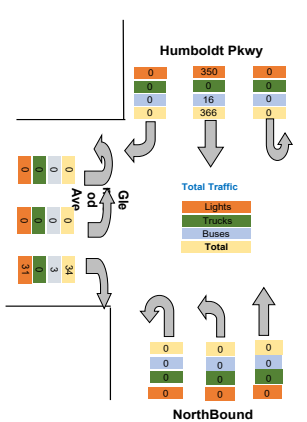

Turning Movement Peak Hour Data (PM)

4:15:00 PM

Leg Direction	Humboldt Pkwy Southbound						Humboldt Pkwy NorthBound						Glenwood Ave Eastbound														
	Right	Thru	U-Turn	App	Total	Peds	CW	Peds	CCW	Thru	Left	U-Turn	App	Total	Peds	CW	Peds	CCW	Right	Left	U-Turn	App	Total	Peds	CW	Peds	CCW
4:15:00 PM	0	108	0	108	0	0	0	0	0	0	0	0	0	0	0	0	0	0	5	0	0	5	0	0	0	0	0
4:30:00 PM	0	119	0	119	0	0	0	0	0	0	0	0	0	0	0	0	0	0	6	0	0	6	0	0	0	0	3
4:45:00 PM	0	112	0	112	0	0	0	0	0	0	0	0	0	0	0	0	0	0	4	0	0	4	0	0	0	0	0
5:00:00 PM	0	109	0	109	0	0	0	0	0	0	0	0	0	0	0	0	0	0	8	0	0	8	0	0	0	0	1
Grand Total	0	448	0	448	0	0	0	0	0	0	0	0	0	0	0	0	0	0	23	0	0	23	0	0	0	0	4
% Approach	0.0%	100.0%	0.0%	0.0%	0.0%	0.0%	0.0%	14.2%	0.0%	0.0%	0.0%	0.0%	0.0%	0.0%	0.0%	0.0%	0.0%	45.1%	41.7%	0.0%	0.0%	0.0%	0.0%	0.0%	0.0%	0.0%	
% Total	0.0%	95.1%	0.0%	95.1%	0.0%	0.0%	0.0%	0.0%	0.0%	0.0%	0.0%	0.0%	0.0%	0.0%	0.0%	0.0%	0.0%	4.9%	0.0%	0.0%	4.9%	0.0%	0.0%	0.0%	0.0%	0.0%	
PHF	0.000	0.941	0.000	0.941	0.000	0.000	0.000	0.000	0.000	0.000	0.000	0.000	0.000	0.000	0.000	0.000	0.000	0.719	0.000	0.000	0.719	0.000	0.000	0.000	0.000	0.000	
Lights	0	431	0	431	0	0	0	0	0	0	0	0	0	0	0	0	0	22	0	0	22	0	0	0	0	0	
% Lights	0.0%	96.2%	0.0%	96.2%	0.0%	0.0%	0.0%	0.0%	0.0%	0.0%	0.0%	0.0%	0.0%	0.0%	0.0%	0.0%	0.0%	95.7%	0.0%	0.0%	95.7%	0.0%	0.0%	0.0%	0.0%	0.0%	
Trucks	0	0	0	0	0	0	0	0	0	0	0	0	0	0	0	0	0	0	0	0	0	0	0	0	0	0	
% Trucks	0.0%	0.0%	0.0%	0.0%	0.0%	0.0%	0.0%	0.0%	0.0%	0.0%	0.0%	0.0%	0.0%	0.0%	0.0%	0.0%	0.0%	0.0%	0.0%	0.0%	0.0%	0.0%	0.0%	0.0%	0.0%	0.0%	
Buses	0	17	0	17	0	0	0	0	0	0	0	0	0	0	0	0	0	1	0	0	1	0	0	0	0	0	
% Buses	0.0%	3.8%	0.0%	3.8%	0.0%	0.0%	0.0%	0.0%	0.0%	0.0%	0.0%	0.0%	0.0%	0.0%	0.0%	0.0%	0.0%	4.3%	0.0%	0.0%	4.3%	0.0%	0.0%	0.0%	0.0%	0.0%	
Pedestrians	0	0	0	0	0	0	0	0	0	0	0	0	0	0	0	0	0	0	0	0	0	0	0	0	0	4	
% Pedestrians	0.0%	0.0%	0.0%	0.0%	0.0%	0.0%	0.0%	0.0%	0.0%	0.0%	0.0%	0.0%	0.0%	0.0%	0.0%	0.0%	0.0%	0.0%	0.0%	0.0%	0.0%	0.0%	0.0%	0.0%	100.0%	0.0%	
Bicycles on Crosswalk	0	0	0	0	0	0	0	0	0	0	0	0	0	0	0	0	0	0	0	0	0	0	0	0	0	0	
% Bicycles on Crosswalk	0.0%	0.0%	0.0%	0.0%	0.0%	0.0%	0.0%	0.0%	0.0%	0.0%	0.0%	0.0%	0.0%	0.0%	0.0%	0.0%	0.0%	0.0%	0.0%	0.0%	0.0%	0.0%	0.0%	0.0%	0.0%	0.0%	

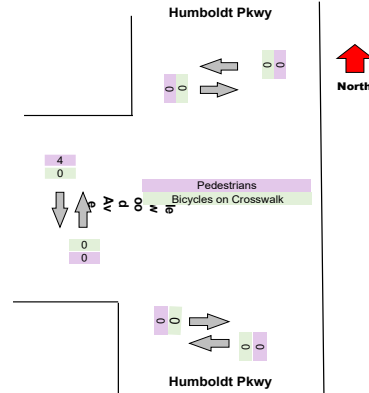
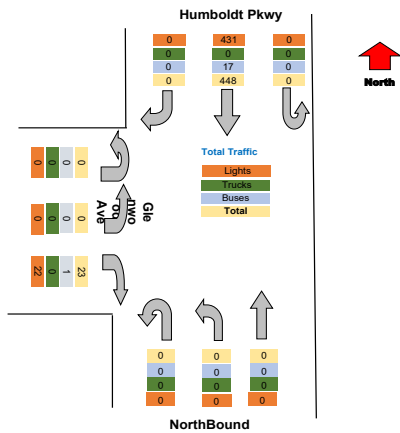

Intersection: Elm St Pine St
 Location: Kennett Square, PA
 Site: 01
 Survey Date: Wednesday, 04-28-2021
 GPS: 42.948550, -72.790034



Total
40
62
102
47
59
106
99
311
79
116
195
170
113
125
116
524
117
100
95
84
396
1528
0.0%
0.0%
1469
96.1%
0
0.0%
59
3.9%
0
0.0%
0.0%

Intersection: Elm St Pine St
Location: Kennett Square, PA
Site: 01
Survey Date: Wednesday, 04-28-2021
GPS: 42.948550, -72.790034



Total
106
99
79
116
400
0.862
381
95.3%
0
0.0%
19
4.8%
0
0.0%
0
0.0%

Intersection: Elm St Pine St
Location: Kennett Square, PA
Site: 01
Survey Date: Wednesday, 04-28-2021
GPS: 42.948550, -72.790034



Total
113
125
116
117
471
0.942
453
96.2%
0
0.0%
18
3.8%
0
0.0%
0
0.0%

Project	Labella
Project Code	Labella
Site Name	B
Legs and Movements	All Processed Legs & Movements
Bin Size	15 minutes
Survey Date	2021-10-27, Wednesday
Location	B
Latitude and Longitude	42.912267, -78.843718

	Start	End	PHF
Forced Peak AM	2021/10/27 07:30:00	2021/10/27 08:30:00	0.952
Forced Peak PM	2021/10/27 16:30:00	2021/10/27 17:30:00	0.877
AM Peak	2021/10/27 07:30:00	2021/10/27 08:30:00	0.952
PM Peak	2021/10/27 16:15:00	2021/10/27 17:15:00	0.873

Turning Movement Data

Leg Direction	Humboldt Pkwy Southbound						Humboldt Pkwy NorthBound						Glenwood Ave Eastbound											
	Right	Thru	U-Turn	App Total	Peds	CW	Peds	CCW	Thru	Left	U-Turn	App Total	Peds	CW	Peds	CCW	Right	Left	U-Turn	App Total	Peds	CW	Peds	CCW
Start Time	0	43	0	43	0	0	0	0	0	0	0	0	0	0	0	0	3	0	0	3	0	0	0	2
6:30:00 AM	0	50	0	50	0	0	0	0	0	0	0	0	0	0	0	0	3	0	0	3	0	0	0	2
6:45:00 AM	0	93	0	93	0	0	0	0	0	0	0	0	0	0	0	0	6	0	0	6	0	0	0	4
Hourly Total	0	93	0	93	0	0	0	0	0	0	0	0	0	0	0	0	6	0	0	6	0	0	0	4
7:00:00 AM	0	37	0	37	0	0	0	0	0	0	0	0	0	0	0	0	1	0	0	1	2	1	0	1
7:15:00 AM	0	61	0	61	0	0	0	0	0	0	0	0	0	0	0	0	4	0	0	4	0	0	0	0
7:30:00 AM	0	79	0	79	0	0	0	0	0	0	0	0	0	0	0	0	12	0	0	12	1	0	0	0
7:45:00 AM	0	99	0	99	0	0	0	0	0	0	0	0	0	0	0	0	5	0	0	5	0	0	0	1
Hourly Total	0	276	0	276	0	0	0	0	0	0	0	0	0	0	0	0	22	0	0	22	3	2	0	2
8:00:00 AM	0	93	0	93	0	0	0	0	0	0	0	0	0	0	0	0	4	0	0	4	1	0	0	0
8:15:00 AM	0	101	0	101	0	0	0	0	0	0	0	0	0	0	0	0	3	0	0	3	0	0	0	0
Hourly Total	0	194	0	194	0	0	0	0	0	0	0	0	0	0	0	0	7	0	0	7	1	0	0	0
4:00:00 PM	0	114	0	114	0	0	0	0	0	0	0	0	0	0	0	0	10	0	0	10	1	0	0	0
4:15:00 PM	0	108	0	108	0	0	0	0	0	0	0	0	0	0	0	0	5	0	0	5	2	0	0	0
4:30:00 PM	0	117	0	117	0	0	0	0	0	0	0	0	0	0	0	0	11	0	0	11	4	0	0	0
4:45:00 PM	0	84	0	84	0	0	0	0	0	0	0	0	0	0	0	0	9	0	0	9	0	0	0	0
Hourly Total	0	423	0	423	0	0	0	0	0	0	0	0	0	0	0	0	35	0	0	35	7	0	0	0
5:00:00 PM	0	110	0	110	0	0	0	0	0	0	0	0	0	0	0	0	3	0	0	3	1	1	0	1
5:15:00 PM	0	105	0	105	0	0	0	0	0	0	0	0	0	0	0	0	10	0	0	10	1	0	0	0
5:30:00 PM	0	94	0	94	0	0	0	0	0	0	0	0	0	0	0	0	3	0	0	3	0	0	0	0
5:45:00 PM	0	87	0	87	0	0	0	0	0	0	0	0	0	0	0	0	3	0	0	3	0	0	0	0
Hourly Total	0	396	0	396	0	0	0	0	0	0	0	0	0	0	0	0	19	0	0	19	2	1	0	1
Grand Total	0	1382	0	1382	0	0	0	0	0	0	0	0	0	0	0	0	89	0	0	89	13	7	0	7
% Approach	0.0%	100.0%	0.0%	0.0%	0.0%	0.0%	0.0%	0.0%	0.0%	0.0%	0.0%	0.0%	0.0%	0.0%	0.0%	0.0%	100.0%	0.0%	0.0%	0.0%	0.0%	0.0%	0.0%	0.0%
% Total	0.0%	93.9%	0.0%	93.9%	0.0%	0.0%	0.0%	0.0%	0.0%	0.0%	0.0%	0.0%	0.0%	0.0%	0.0%	0.0%	6.1%	0.0%	0.0%	6.1%	0.0%	0.0%	0.0%	0.0%
Lights	0	1333	0	1333	0	0	0	0	0	0	0	0	0	0	0	0	80	0	0	80	0	0	0	0
% Lights	0.0%	96.5%	0.0%	96.5%	0.0%	0.0%	0.0%	0.0%	0.0%	0.0%	0.0%	0.0%	0.0%	0.0%	0.0%	0.0%	89.9%	0.0%	0.0%	89.9%	0.0%	0.0%	0.0%	0.0%
Trucks	0	0	0	0	0	0	0	0	0	0	0	0	0	0	0	0	0	0	0	0	0	0	0	0
% Trucks	0.0%	0.0%	0.0%	0.0%	0.0%	0.0%	0.0%	0.0%	0.0%	0.0%	0.0%	0.0%	0.0%	0.0%	0.0%	0.0%	0.0%	0.0%	0.0%	0.0%	0.0%	0.0%	0.0%	0.0%
Buses	0	48	0	48	0	0	0	0	0	0	0	0	0	0	0	0	9	0	0	9	0	0	0	0
% Buses	0.0%	3.5%	0.0%	3.5%	0.0%	0.0%	0.0%	0.0%	0.0%	0.0%	0.0%	0.0%	0.0%	0.0%	0.0%	0.0%	10.1%	0.0%	0.0%	10.1%	0.0%	0.0%	0.0%	0.0%
Pedestrians	0	0	0	0	0	0	0	0	0	0	0	0	0	0	0	0	0	0	0	0	11	7	0	7
% Pedestrians	0.0%	0.0%	0.0%	0.0%	0.0%	0.0%	0.0%	0.0%	0.0%	0.0%	0.0%	0.0%	0.0%	0.0%	0.0%	0.0%	0.0%	0.0%	0.0%	0.0%	84.6%	100.0%	0.0%	100.0%
% Bicycles on Crosswalk	0.0%	0.0%	0.0%	0.0%	0.0%	0.0%	0.0%	0.0%	0.0%	0.0%	0.0%	0.0%	0.0%	0.0%	0.0%	0.0%	0.0%	0.0%	0.0%	0.0%	15.4%	0.0%	0.0%	0.0%

Turning Movement Data Plot

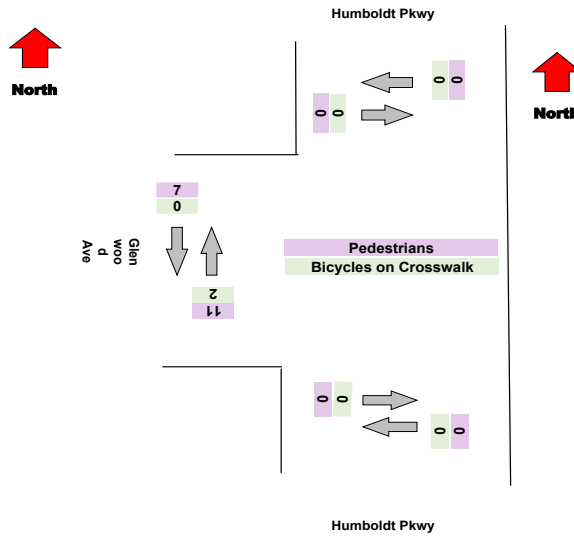
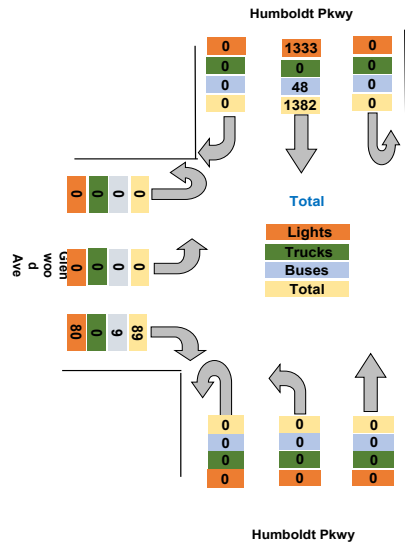

Turning Movement Peak Hour Data (AM)

7:30:00 AM

Leg Direction	Humboldt Pkwy Southbound						Humboldt Pkwy NorthBound						Glenwood Ave Eastbound					
	Right	Thru	U-Turn	App Total	Peds CW	Peds CCW	Thru	Left	U-Turn	App Total	Peds CW	Peds CCW	Right	Left	U-Turn	App Total	Peds CW	Peds CCW
7:30:00 AM	0	79	0	79	0	0	0	0	0	0	0	0	12	0	0	12	1	0
7:45:00 AM	0	99	0	99	0	0	0	0	0	0	0	0	5	0	0	5	0	1
8:00:00 AM	0	93	0	93	0	0	0	0	0	0	0	0	4	0	0	4	1	0
8:15:00 AM	0	101	0	101	0	0	0	0	0	0	0	0	3	0	0	3	0	0
Grand Total	0	372	0	372	0	0	0	0	0	0	0	0	24	0	0	24	2	1
% Approach	0.0%	100.0%	0.0%	0.0%	0.0%	0.0%	14.2%	0.0%	0.0%	0.0%	0.0%	0.0%	45.1%	41.7%	0.0%	0.0%	0.0%	0.0%
% Total	0.0%	93.9%	0.0%	93.9%	0.0%	0.0%	0.0%	0.0%	0.0%	0.0%	0.0%	0.0%	6.1%	0.0%	0.0%	6.1%	0.0%	0.0%
PHF	0.000	0.921	0.000	0.921	0.000	0.000	0.000	0.000	0.000	0.000	0.000	0.000	0.500	0.000	0.000	0.500	0.000	0.000
Lights	0	356	0	356	0	0	0	0	0	0	0	0	20	0	0	20	0	0
% Lights	0.0%	95.7%	0.0%	95.7%	0.0%	0.0%	0.0%	0.0%	0.0%	0.0%	0.0%	0.0%	83.3%	0.0%	0.0%	83.3%	0.0%	0.0%
Trucks	0	0	0	0	0	0	0	0	0	0	0	0	0	0	0	0	0	0
% Trucks	0.0%	0.0%	0.0%	0.0%	0.0%	0.0%	0.0%	0.0%	0.0%	0.0%	0.0%	0.0%	0.0%	0.0%	0.0%	0.0%	0.0%	0.0%
Buses	0	16	0	16	0	0	0	0	0	0	0	0	4	0	0	4	0	0
% Buses	0.0%	4.3%	0.0%	4.3%	0.0%	0.0%	0.0%	0.0%	0.0%	0.0%	0.0%	0.0%	16.7%	0.0%	0.0%	16.7%	0.0%	0.0%
Pedestrians	0	0	0	0	0	0	0	0	0	0	0	0	0	0	0	0	2	1
% Pedestrians	0.0%	0.0%	0.0%	0.0%	0.0%	0.0%	0.0%	0.0%	0.0%	0.0%	0.0%	0.0%	0.0%	0.0%	0.0%	0.0%	100.0%	100.0%
Bicycles on Crosswalk	0	0	0	0	0	0	0	0	0	0	0	0	0	0	0	0	0	0
% Bicycles on Crosswalk	0.0%	0.0%	0.0%	0.0%	0.0%	0.0%	0.0%	0.0%	0.0%	0.0%	0.0%	0.0%	0.0%	0.0%	0.0%	0.0%	0.0%	0.0%

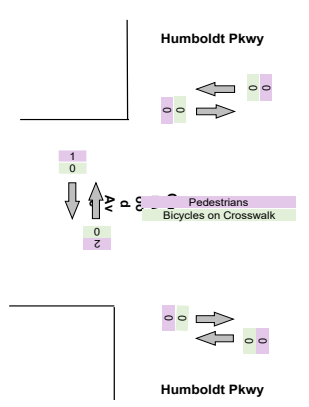
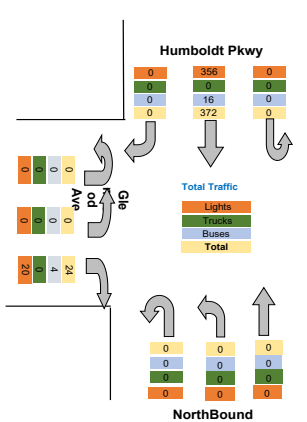

Turning Movement Peak Hour Data (PM)
 4:15:00 PM

Leg Direction	Humboldt Pkwy Southbound						Humboldt Pkwy NorthBound						Glenwood Ave Eastbound					
	Right	Thru	U-Turn	App Total	Peds CW	Peds CCW	Thru	Left	U-Turn	App Total	Peds CW	Peds CCW	Right	Left	U-Turn	App Total	Peds CW	Peds CCW
4:15:00 PM	0	108	0	108	0	0	0	0	0	0	0	0	5	0	0	5	2	0
4:30:00 PM	0	117	0	117	0	0	0	0	0	0	0	0	11	0	0	11	4	0
4:45:00 PM	0	84	0	84	0	0	0	0	0	0	0	0	9	0	0	9	0	0
5:00:00 PM	0	110	0	110	0	0	0	0	0	0	0	0	3	0	0	3	1	1
Grand Total	0	419	0	419	0	0	0	0	0	0	0	0	28	0	0	28	7	1
% Approach	0.0%	100.0%	0.0%	0.0%	0.0%	0.0%	14.2%	0.0%	0.0%	0.0%	0.0%	0.0%	45.1%	41.7%	0.0%	0.0%	0.0%	0.0%
% Total	0.0%	93.7%	0.0%	93.7%	0.0%	0.0%	0.0%	0.0%	0.0%	0.0%	0.0%	0.0%	6.3%	0.0%	0.0%	6.3%	0.0%	0.0%
PHF	0.000	0.895	0.000	0.895	0.000	0.000	0.000	0.000	0.000	0.000	0.000	0.000	0.636	0.000	0.000	0.636	0.000	0.000
Lights	0	406	0	406	0	0	0	0	0	0	0	0	27	0	0	27	0	0
% Lights	0.0%	96.9%	0.0%	96.9%	0.0%	0.0%	0.0%	0.0%	0.0%	0.0%	0.0%	0.0%	96.4%	0.0%	0.0%	96.4%	0.0%	0.0%
Trucks	0	0	0	0	0	0	0	0	0	0	0	0	0	0	0	0	0	0
% Trucks	0.0%	0.0%	0.0%	0.0%	0.0%	0.0%	0.0%	0.0%	0.0%	0.0%	0.0%	0.0%	0.0%	0.0%	0.0%	0.0%	0.0%	0.0%
Buses	0	12	0	12	0	0	0	0	0	0	0	0	0	0	0	1	0	0
% Buses	0.0%	2.9%	0.0%	0.0%	0.0%	0.0%	0.0%	0.0%	0.0%	0.0%	0.0%	0.0%	3.6%	0.0%	0.0%	0.0%	0.0%	0.0%
Pedestrians	0	0	0	0	0	0	0	0	0	0	0	0	0	0	0	0	6	1
% Pedestrians	0.0%	0.0%	0.0%	0.0%	0.0%	0.0%	0.0%	0.0%	0.0%	0.0%	0.0%	0.0%	0.0%	0.0%	0.0%	0.0%	85.7%	100.0%
Bicycles on Crosswalk	0	0	0	0	0	0	0	0	0	0	0	0	0	0	0	0	1	0
% Bicycles on Crosswalk	0.0%	0.0%	0.0%	0.0%	0.0%	0.0%	0.0%	0.0%	0.0%	0.0%	0.0%	0.0%	0.0%	0.0%	0.0%	0.0%	14.3%	0.0%

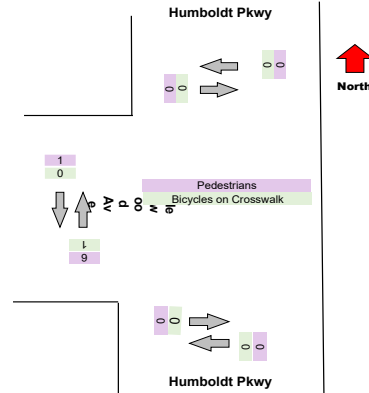
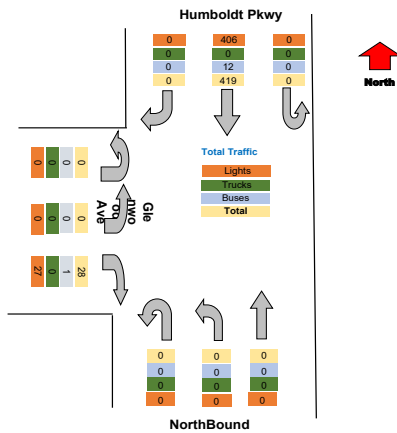

Intersection: Elm St Pine St
 Location: Kennett Square, PA
 Site: 01
 Survey Date: Wednesday, 04-28-2021
 GPS: 42.948550, -72.790034



Total
46
53
99
38
65
91
104
298
97
104
201
124
113
128
93
458
113
115
97
90
415
1471
0.0%
0.0%
1413
96.1%
0
0.0%
57
3.9%
0
0.0%
0.0%

Intersection: Elm St Pine St
Location: Kennett Square, PA
Site: 01
Survey Date: Wednesday, 04-28-2021
GPS: 42.948550, -72.790034



Total
91
104
97
104
396
0.952
376
94.9%
0
0.0%
20
5.1%
0
0.0%
0
0.0%

Intersection: Elm St Pine St
Location: Kennett Square, PA
Site: 01
Survey Date: Wednesday, 04-28-2021
GPS: 42.948550, -72.790034



Total
113
128
93
113
447
0.873
433
96.9%
0
0.0%
13
2.9%
0
0.0%
0
0.0%

Project	Labella
Project Code	Labella
Site Name	B
Legs and Movements	All Processed Legs & Movements
Bin Size	15 minutes
Survey Date	2021-10-28, Thursday
Location	B
Latitude and Longitude	42.912267, -78.843718

	Start	End	PHF
Forced Peak AM	2021/10/28 07:30:00	2021/10/28 08:30:00	0.807
Forced Peak PM	2021/10/28 16:30:00	2021/10/28 17:30:00	0.894
AM Peak	2021/10/28 07:30:00	2021/10/28 08:30:00	0.807
PM Peak	2021/10/28 16:15:00	2021/10/28 17:15:00	0.879

Turning Movement Data

Leg Direction	Humboldt Pkwy Southbound						Humboldt Pkwy NorthBound						Glenwood Ave Eastbound											
	Right	Thru	U-Turn	App Total	Peds	CW	Peds	CCW	Thru	Left	U-Turn	App Total	Peds	CW	Peds	CCW	Right	Left	U-Turn	App Total	Peds	CW	Peds	CCW
Start Time	0	37	0	37	0	0	0	0	0	0	0	0	0	0	0	0	4	0	0	4	0	0	2	2
6:30:00 AM	0	57	0	57	0	0	0	0	0	0	0	0	0	0	0	0	6	0	0	6	0	0	2	2
6:45:00 AM	0	94	0	94	0	0	0	0	0	0	0	0	0	0	0	0	10	0	0	10	0	0	4	4
Hourly Total	0	94	0	94	0	0	0	0	0	0	0	0	0	0	0	0	10	0	0	10	0	0	4	4
7:00:00 AM	0	37	0	37	0	0	0	0	0	0	0	0	0	0	0	0	6	0	0	6	1	1	1	1
7:15:00 AM	0	57	0	57	0	0	0	0	0	0	0	0	0	0	0	0	7	0	0	7	0	0	1	1
7:30:00 AM	0	85	0	85	0	0	0	0	0	0	0	0	0	0	0	0	11	0	0	11	2	1	1	1
7:45:00 AM	0	129	0	129	0	0	0	0	0	0	0	0	0	0	0	0	7	0	0	7	0	0	2	2
Hourly Total	0	308	0	308	0	0	0	0	0	0	0	0	0	0	0	0	31	0	0	31	3	5	5	5
8:00:00 AM	0	98	0	98	0	0	0	0	0	0	0	0	0	0	0	0	2	0	0	2	0	0	0	0
8:15:00 AM	0	100	0	100	0	0	0	0	0	0	0	0	0	0	0	0	7	0	0	7	0	0	0	0
Hourly Total	0	198	0	198	0	0	0	0	0	0	0	0	0	0	0	0	9	0	0	9	0	0	0	0
4:00:00 PM	0	128	0	128	0	0	0	0	0	0	0	0	0	0	0	0	8	0	0	8	0	0	0	0
4:15:00 PM	0	134	0	134	0	0	0	0	0	0	0	0	0	0	0	0	11	0	0	11	1	1	0	0
4:30:00 PM	0	128	0	128	0	0	0	0	0	0	0	0	0	0	0	0	4	0	0	4	0	0	0	0
4:45:00 PM	0	103	0	103	0	0	0	0	0	0	0	0	0	0	0	0	13	0	0	13	2	2	2	2
Hourly Total	0	493	0	493	0	0	0	0	0	0	0	0	0	0	0	0	36	0	0	36	3	2	2	2
5:00:00 PM	0	110	0	110	0	0	0	0	0	0	0	0	0	0	0	0	7	0	0	7	0	0	2	2
5:15:00 PM	0	103	0	103	0	0	0	0	0	0	0	0	0	0	0	0	4	0	0	4	2	3	3	3
5:30:00 PM	0	103	0	103	0	0	0	0	0	0	0	0	0	0	0	0	8	0	0	8	0	0	0	0
5:45:00 PM	0	107	0	107	0	0	0	0	0	0	0	0	0	0	0	0	5	0	0	5	3	1	1	1
Hourly Total	0	423	0	423	0	0	0	0	0	0	0	0	0	0	0	0	24	0	0	24	5	6	6	6
Grand Total	0	1516	0	1516	0	0	0	0	0	0	0	0	0	0	0	0	110	0	0	110	11	17	17	17
% Approach	0.0%	100.0%	0.0%	0.0%	0.0%	0.0%	0.0%	0.0%	0.0%	0.0%	0.0%	0.0%	0.0%	0.0%	0.0%	0.0%	100.0%	0.0%	0.0%	0.0%	0.0%	0.0%	0.0%	0.0%
% Total	0.0%	93.2%	0.0%	93.2%	0.0%	0.0%	0.0%	0.0%	0.0%	0.0%	0.0%	0.0%	0.0%	0.0%	0.0%	0.0%	6.8%	0.0%	0.0%	6.8%	0.0%	0.0%	0.0%	0.0%
Lights	0	1470	0	1470	0	0	0	0	0	0	0	0	0	0	0	0	101	0	0	101	0	0	0	0
% Lights	0.0%	97.0%	0.0%	97.0%	0.0%	0.0%	0.0%	0.0%	0.0%	0.0%	0.0%	0.0%	0.0%	0.0%	0.0%	0.0%	91.8%	0.0%	0.0%	91.8%	0.0%	0.0%	0.0%	0.0%
Trucks	0	1	0	1	0	0	0	0	0	0	0	0	0	0	0	0	0	0	0	0	0	0	0	0
% Trucks	0.0%	0.1%	0.0%	0.1%	0.0%	0.0%	0.0%	0.0%	0.0%	0.0%	0.0%	0.0%	0.0%	0.0%	0.0%	0.0%	0.0%	0.0%	0.0%	0.0%	0.0%	0.0%	0.0%	0.0%
Buses	0	44	0	44	0	0	0	0	0	0	0	0	0	0	0	0	9	0	0	9	0	0	0	0
% Buses	0.0%	2.9%	0.0%	0.0%	0.0%	0.0%	0.0%	0.0%	0.0%	0.0%	0.0%	0.0%	0.0%	0.0%	0.0%	0.0%	8.2%	0.0%	0.0%	0.0%	0.0%	0.0%	0.0%	0.0%
Pedestrians	0	0	0	0	0	0	0	0	0	0	0	0	0	0	0	0	0	0	0	0	10	16	16	16
% Pedestrians	0.0%	0.0%	0.0%	0.0%	0.0%	0.0%	0.0%	0.0%	0.0%	0.0%	0.0%	0.0%	0.0%	0.0%	0.0%	0.0%	0.0%	0.0%	0.0%	0.0%	90.9%	94.1%	94.1%	94.1%
% Bicycles on Crosswalk	0.0%	0.0%	0.0%	0.0%	0.0%	0.0%	0.0%	0.0%	0.0%	0.0%	0.0%	0.0%	0.0%	0.0%	0.0%	0.0%	0.0%	0.0%	0.0%	0.0%	9.1%	5.9%	5.9%	5.9%

Turning Movement Data Plot

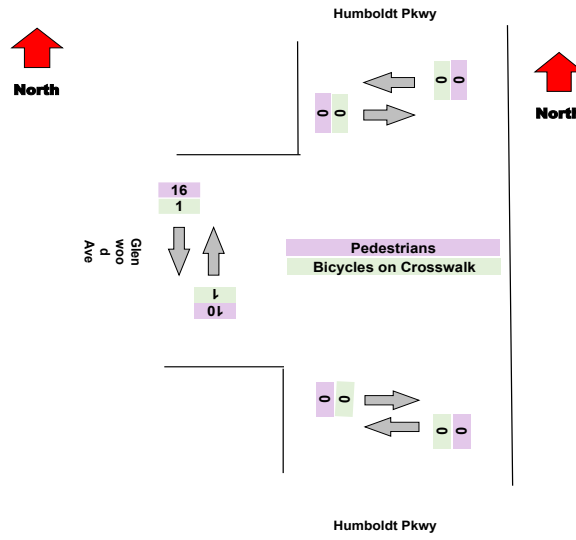
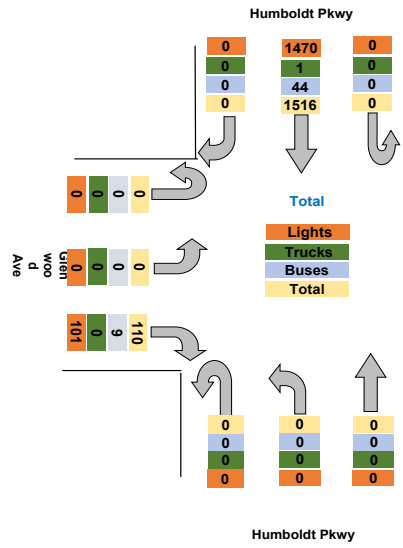

Turning Movement Peak Hour Data (AM)

7:30:00 AM

Leg Direction	Humboldt Pkwy Southbound						Humboldt Pkwy NorthBound						Glenwood Ave Eastbound					
	Right	Thru	U-Turn	App Total	Peds CW	Peds CCW	Thru	Left	U-Turn	App Total	Peds CW	Peds CCW	Right	Left	U-Turn	App Total	Peds CW	Peds CCW
7:30:00 AM	0	85	0	85	0	0	0	0	0	0	0	0	11	0	0	11	2	1
7:45:00 AM	0	129	0	129	0	0	0	0	0	0	0	0	7	0	0	7	0	2
8:00:00 AM	0	98	0	98	0	0	0	0	0	0	0	0	2	0	0	2	0	0
8:15:00 AM	0	100	0	100	0	0	0	0	0	0	0	0	7	0	0	7	0	0
Grand Total	0	412	0	412	0	0	0	0	0	0	0	0	27	0	0	27	2	3
% Approach	0.0%	100.0%	0.0%	0.0%	0.0%	0.0%	14.2%	0.0%	0.0%	0.0%	0.0%	0.0%	45.1%	41.7%	0.0%	0.0%	0.0%	0.0%
% Total	0.0%	93.8%	0.0%	93.8%	0.0%	0.0%	0.0%	0.0%	0.0%	0.0%	0.0%	0.0%	6.2%	0.0%	0.0%	6.2%	0.0%	0.0%
PHF	0.000	0.798	0.000	0.798	0.000	0.000	0.000	0.000	0.000	0.000	0.000	0.000	0.614	0.000	0.000	0.614	0.000	0.000
Lights	0	396	0	396	0	0	0	0	0	0	0	0	24	0	0	24	0	0
% Lights	0.0%	96.1%	0.0%	96.1%	0.0%	0.0%	0.0%	0.0%	0.0%	0.0%	0.0%	0.0%	88.9%	0.0%	0.0%	88.9%	0.0%	0.0%
Trucks	0	1	0	1	0	0	0	0	0	0	0	0	0	0	0	0	0	0
% Trucks	0.0%	0.2%	0.0%	0.2%	0.0%	0.0%	0.0%	0.0%	0.0%	0.0%	0.0%	0.0%	0.0%	0.0%	0.0%	0.0%	0.0%	0.0%
Buses	0	15	0	15	0	0	0	0	0	0	0	0	3	0	0	3	0	0
% Buses	0.0%	3.6%	0.0%	3.6%	0.0%	0.0%	0.0%	0.0%	0.0%	0.0%	0.0%	0.0%	11.1%	0.0%	0.0%	11.1%	0.0%	0.0%
Pedestrians	0	0	0	0	0	0	0	0	0	0	0	0	0	0	0	0	2	3
% Pedestrians	0.0%	0.0%	0.0%	0.0%	0.0%	0.0%	0.0%	0.0%	0.0%	0.0%	0.0%	0.0%	0.0%	0.0%	0.0%	0.0%	100.0%	100.0%
Bicycles on Crosswalk	0	0	0	0	0	0	0	0	0	0	0	0	0	0	0	0	0	0
% Bicycles on Crosswalk	0.0%	0.0%	0.0%	0.0%	0.0%	0.0%	0.0%	0.0%	0.0%	0.0%	0.0%	0.0%	0.0%	0.0%	0.0%	0.0%	0.0%	0.0%

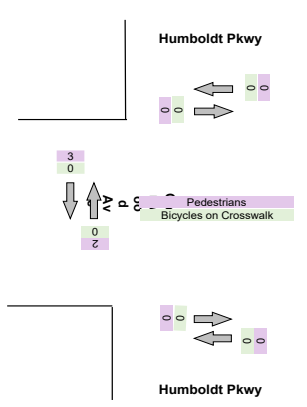
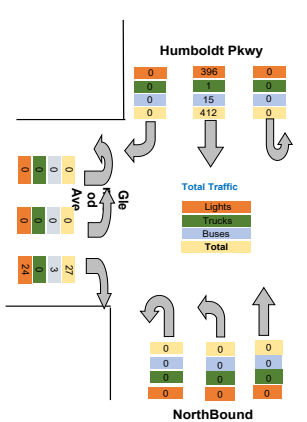

Turning Movement Peak Hour Data (PM)

4:15:00 PM

Leg Direction	Humboldt Pkwy Southbound						Humboldt Pkwy NorthBound						Glenwood Ave Eastbound					
	Right	Thru	U-Turn	App Total	Peds CW	Peds CCW	Thru	Left	U-Turn	App Total	Peds CW	Peds CCW	Right	Left	U-Turn	App Total	Peds CW	Peds CCW
4:15:00 PM	0	134	0	134	0	0	0	0	0	0	0	0	11	0	0	11	1	0
4:30:00 PM	0	128	0	128	0	0	0	0	0	0	0	0	4	0	0	4	0	0
4:45:00 PM	0	103	0	103	0	0	0	0	0	0	0	0	13	0	0	13	2	2
5:00:00 PM	0	110	0	110	0	0	0	0	0	0	0	0	7	0	0	7	0	2
Grand Total	0	475	0	475	0	0	0	0	0	0	0	0	35	0	0	35	3	4
% Approach	0.0%	100.0%	0.0%	0.0%	0.0%	0.0%	14.2%	0.0%	0.0%	0.0%	0.0%	0.0%	45.1%	41.7%	0.0%	0.0%	0.0%	0.0%
% Total	0.0%	93.1%	0.0%	93.1%	0.0%	0.0%	0.0%	0.0%	0.0%	0.0%	0.0%	0.0%	6.9%	0.0%	0.0%	6.9%	0.0%	0.0%
PHF	0.000	0.886	0.000	0.886	0.000	0.000	0.000	0.000	0.000	0.000	0.000	0.000	0.673	0.000	0.000	0.673	0.000	0.000
Lights	0	458	0	458	0	0	0	0	0	0	0	0	34	0	0	34	0	0
% Lights	0.0%	96.4%	0.0%	96.4%	0.0%	0.0%	0.0%	0.0%	0.0%	0.0%	0.0%	0.0%	97.1%	0.0%	0.0%	97.1%	0.0%	0.0%
Trucks	0	0	0	0	0	0	0	0	0	0	0	0	0	0	0	0	0	0
% Trucks	0.0%	0.0%	0.0%	0.0%	0.0%	0.0%	0.0%	0.0%	0.0%	0.0%	0.0%	0.0%	0.0%	0.0%	0.0%	0.0%	0.0%	0.0%
Buses	0	16	0	16	0	0	0	0	0	0	0	0	1	0	0	1	0	0
% Buses	0.0%	3.4%	0.0%	3.4%	0.0%	0.0%	0.0%	0.0%	0.0%	0.0%	0.0%	0.0%	2.9%	0.0%	0.0%	2.9%	0.0%	0.0%
Pedestrians	0	0	0	0	0	0	0	0	0	0	0	0	0	0	0	0	2	3
% Pedestrians	0.0%	0.0%	0.0%	0.0%	0.0%	0.0%	0.0%	0.0%	0.0%	0.0%	0.0%	0.0%	0.0%	0.0%	0.0%	0.0%	66.7%	75.0%
Bicycles on Crosswalk	0	0	0	0	0	0	0	0	0	0	0	0	0	0	0	0	1	1
% Bicycles on Crosswalk	0.0%	0.0%	0.0%	0.0%	0.0%	0.0%	0.0%	0.0%	0.0%	0.0%	0.0%	0.0%	0.0%	0.0%	0.0%	0.0%	33.3%	25.0%

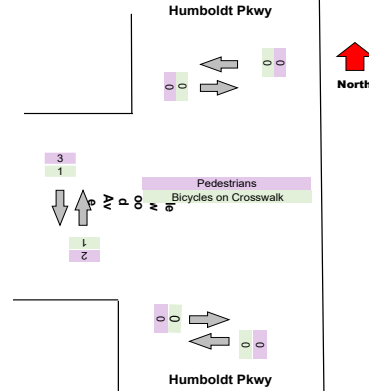
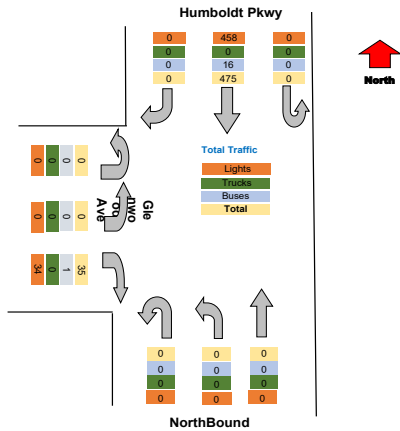

Intersection: Elm St Pine St
 Location: Kennett Square, PA
 Site: 01
 Survey Date: Wednesday, 04-28-2021
 GPS: 42.948550, -72.790034



Total
41
63
104
43
64
96
136
339
100
107
207
136
145
132
116
529
117
107
111
112
447
1626
0.0%
0.0%
1571
96.6%
1
0.1%
53
3.3%
0
0.0%
0.0%

Intersection: Elm St Pine St
Location: Kennett Square, PA
Site: 01
Survey Date: Wednesday, 04-28-2021
GPS: 42.948550, -72.790034



Total
96
136
100
107
439
0.807
420
95.7%
1
0.2%
18
4.1%
0
0.0%
0
0.0%

Intersection: Elm St Pine St
Location: Kennett Square, PA
Site: 01
Survey Date: Wednesday, 04-28-2021
GPS: 42.948550, -72.790034



Total
145
132
116
117
510
0.879
492
96.5%
0
0.0%
17
3.3%
0
0.0%
0
0.0%

Turning Movement Data Plot

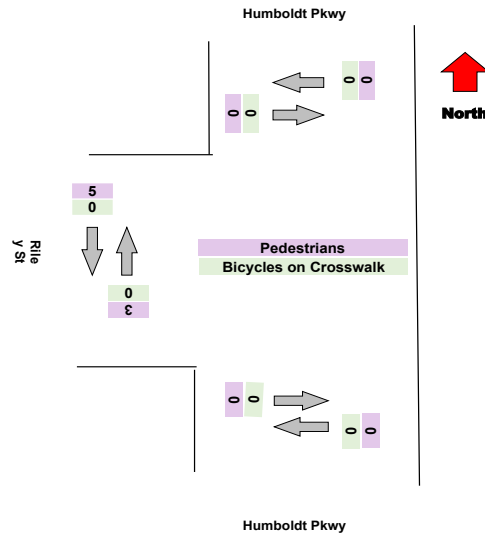
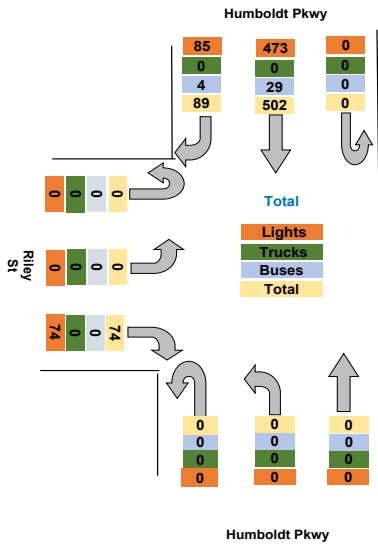

Turning Movement Peak Hour Data (AM)

7:30:00 AM

Leg Direction	Humboldt Pkwy Southbound						Humboldt Pkwy NorthBound						Riley St Eastbound						Total	
	Right	Thru	U-Turn	App Total	Peds CW	Peds CCW	Thru	Left	U-Turn	App Total	Peds CW	Peds CCW	Right	Left	U-Turn	App Total	Peds CW	Peds CCW		
7:30:00 AM	9	27	0	36	0	0	0	0	0	0	0	0	0	0	0	0	0	0	0	36
7:45:00 AM	2	31	0	33	0	0	0	0	0	0	0	0	4	0	0	4	0	0	0	37
8:00:00 AM	3	23	0	26	0	0	0	0	0	0	0	0	5	0	0	5	1	1	1	31
8:15:00 AM	8	29	0	37	0	0	0	0	0	0	0	0	4	0	0	4	0	2	2	41
Grand Total	22	110	0	132	0	0	0	0	0	0	0	0	13	0	0	13	1	3	145	
% Approach	16.7%	83.3%	0.0%	0.0%	0.0%	0.0%	14.2%	0.0%	0.0%	0.0%	0.0%	0.0%	45.1%	41.7%	0.0%	0.0%	0.0%	0.0%	0.0%	0.0%
% Total	15.2%	75.9%	0.0%	91.0%	0.0%	0.0%	0.0%	0.0%	0.0%	0.0%	0.0%	0.0%	9.0%	0.0%	0.0%	9.0%	0.0%	0.0%	0.0%	0.0%
PHF	0.611	0.887	0.000	0.892	0.000	0.000	0.000	0.000	0.000	0.000	0.000	0.000	0.650	0.000	0.000	0.650	0.000	0.000	0.000	0.884
Lights	21	102	0	123	0	0	0	0	0	0	0	0	13	0	0	13	0	0	0	136
% Lights	95.5%	92.7%	0.0%	93.2%	0.0%	0.0%	0.0%	0.0%	0.0%	0.0%	0.0%	0.0%	#####	0.0%	0.0%	100.0%	0.0%	0.0%	0.0%	93.8%
Trucks	0	0	0	0	0	0	0	0	0	0	0	0	0	0	0	0	0	0	0	0
% Trucks	0.0%	0.0%	0.0%	0.0%	0.0%	0.0%	0.0%	0.0%	0.0%	0.0%	0.0%	0.0%	0.0%	0.0%	0.0%	0.0%	0.0%	0.0%	0.0%	0.0%
Buses	1	8	0	9	0	0	0	0	0	0	0	0	0	0	0	0	0	0	0	9
% Buses	4.5%	7.3%	0.0%	0.0%	0.0%	0.0%	0.0%	0.0%	0.0%	0.0%	0.0%	0.0%	0.0%	0.0%	0.0%	0.0%	0.0%	0.0%	0.0%	6.2%
Pedestrians	0	0	0	0	0	0	0	0	0	0	0	0	0	0	0	0	1	3	0	0
% Pedestrians	0.0%	0.0%	0.0%	0.0%	0.0%	0.0%	0.0%	0.0%	0.0%	0.0%	0.0%	0.0%	0.0%	0.0%	0.0%	0.0%	100.0%	100.0%	0.0%	0.0%
Bicycles on Crosswalk	0	0	0	0	0	0	0	0	0	0	0	0	0	0	0	0	0	0	0	0
% Bicycles on Crosswalk	0.0%	0.0%	0.0%	0.0%	0.0%	0.0%	0.0%	0.0%	0.0%	0.0%	0.0%	0.0%	0.0%	0.0%	0.0%	0.0%	0.0%	0.0%	0.0%	0.0%

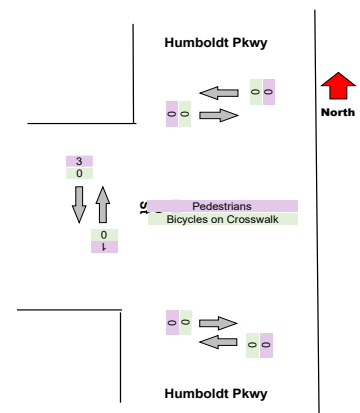
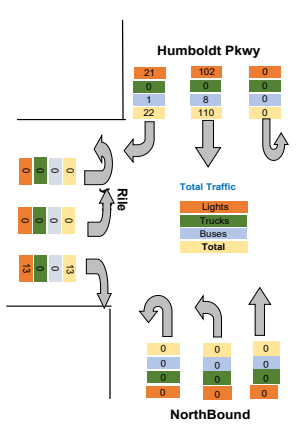

Turning Movement Peak Hour Data (PM)

4:15:00 PM

Leg Direction	Humboldt Pkwy Southbound						Humboldt Pkwy NorthBound						Riley St Eastbound						Total
	Right	Thru	U-Turn	App Total	Peds CW	Peds CCW	Thru	Left	U-Turn	App Total	Peds CW	Peds CCW	Right	Left	U-Turn	App Total	Peds CW	Peds CCW	
4:15:00 PM	5	46	0	51	0	0	0	0	0	0	0	0	6	0	0	6	0	0	57
4:30:00 PM	7	41	0	48	0	0	0	0	0	0	0	0	10	0	0	10	0	0	58
4:45:00 PM	9	36	0	45	0	0	0	0	0	0	0	0	10	0	0	10	2	0	55
5:00:00 PM	7	38	0	45	0	0	0	0	0	0	0	0	3	0	0	3	0	1	48
Grand Total	28	161	0	189	0	0	0	0	0	0	0	0	29	0	0	29	2	1	218
% Approach	14.8%	85.2%	0.0%	0.0%	0.0%	0.0%	14.2%	0.0%	0.0%	0.0%	0.0%	0.0%	45.1%	41.7%	0.0%	0.0%	0.0%	0.0%	0.0%
% Total	12.8%	73.9%	0.0%	86.7%	0.0%	0.0%	0.0%	0.0%	0.0%	0.0%	0.0%	0.0%	13.3%	0.0%	0.0%	13.3%	0.0%	0.0%	0.0%
PHF	0.778	0.875	0.000	0.926	0.000	0.000	0.000	0.000	0.000	0.000	0.000	0.000	0.725	0.000	0.000	0.725	0.000	0.000	0.940
Lights	26	153	0	179	0	0	0	0	0	0	0	0	29	0	0	29	0	0	208
% Lights	92.9%	95.0%	0.0%	94.7%	0.0%	0.0%	0.0%	0.0%	0.0%	0.0%	0.0%	0.0%	#####	0.0%	0.0%	100.0%	0.0%	0.0%	95.4%
Trucks	0	0	0	0	0	0	0	0	0	0	0	0	0	0	0	0	0	0	0
% Trucks	0.0%	0.0%	0.0%	0.0%	0.0%	0.0%	0.0%	0.0%	0.0%	0.0%	0.0%	0.0%	0.0%	0.0%	0.0%	0.0%	0.0%	0.0%	0.0%
Buses	2	8	0	10	0	0	0	0	0	0	0	0	0	0	0	0	0	0	10
% Buses	7.1%	5.0%	0.0%	0.0%	0.0%	0.0%	0.0%	0.0%	0.0%	0.0%	0.0%	0.0%	0.0%	0.0%	0.0%	0.0%	0.0%	0.0%	4.6%
Pedestrians	0	0	0	0	0	0	0	0	0	0	0	0	0	0	0	0	2	1	0
% Pedestrians	0.0%	0.0%	0.0%	0.0%	0.0%	0.0%	0.0%	0.0%	0.0%	0.0%	0.0%	0.0%	0.0%	0.0%	0.0%	0.0%	100.0%	100.0%	0.0%
Bicycles on Crosswalk	0	0	0	0	0	0	0	0	0	0	0	0	0	0	0	0	0	0	0
% Bicycles on Crosswalk	0.0%	0.0%	0.0%	0.0%	0.0%	0.0%	0.0%	0.0%	0.0%	0.0%	0.0%	0.0%	0.0%	0.0%	0.0%	0.0%	0.0%	0.0%	0.0%

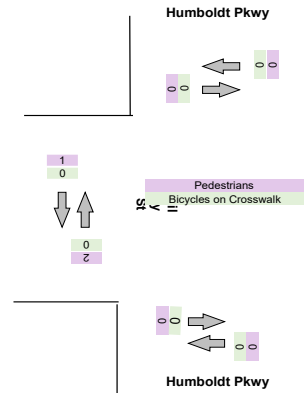
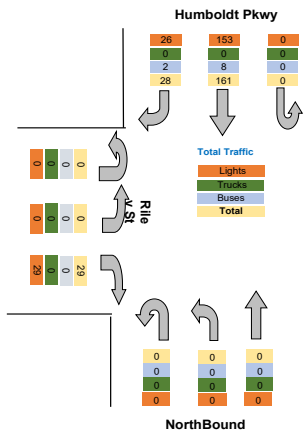

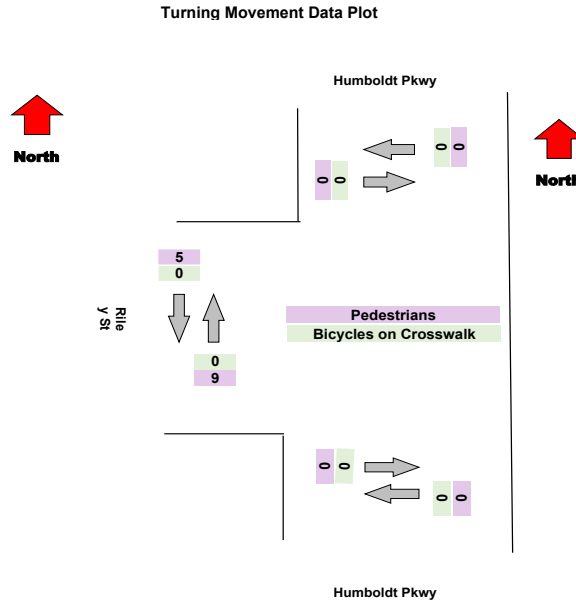
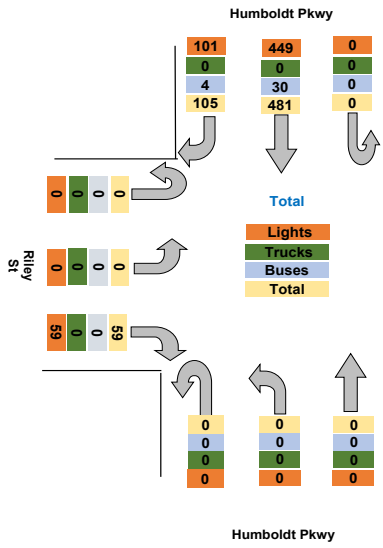

Turning Movement Peak Hour Data (AM)

7:30:00 AM

Leg Direction	Humboldt Pkwy Southbound						Humboldt Pkwy NorthBound						Riley St Eastbound					
	Right	Thru	U-Turn	App Total	Peds CW	Peds CCW	Thru	Left	U-Turn	App Total	Peds CW	Peds CCW	Right	Left	U-Turn	App Total	Peds CW	Peds CCW
7:30:00 AM	7	13	0	20	0	0	0	0	0	0	0	0	1	0	0	1	0	0
7:45:00 AM	3	38	0	41	0	0	0	0	0	0	0	0	2	0	0	2	0	0
8:00:00 AM	6	33	0	39	0	0	0	0	0	0	0	0	6	0	0	6	1	0
8:15:00 AM	12	29	0	41	0	0	0	0	0	0	0	0	6	0	0	6	0	0
Grand Total	28	113	0	141	0	0	0	0	0	0	0	0	15	0	0	15	1	0
% Approach	19.9%	80.1%	0.0%	0.0%	0.0%	0.0%	14.2%	0.0%	0.0%	0.0%	0.0%	0.0%	45.1%	41.7%	0.0%	0.0%	0.0%	0.0%
% Total	17.9%	72.4%	0.0%	90.4%	0.0%	0.0%	0.0%	0.0%	0.0%	0.0%	0.0%	0.0%	9.6%	0.0%	0.0%	9.6%	0.0%	0.0%
PHF	0.583	0.743	0.000	0.860	0.000	0.000	0.000	0.000	0.000	0.000	0.000	0.000	0.625	0.000	0.000	0.625	0.000	0.000
Lights	28	106	0	134	0	0	0	0	0	0	0	0	15	0	0	15	0	0
% Lights	100.0%	93.8%	0.0%	95.0%	0.0%	0.0%	0.0%	0.0%	0.0%	0.0%	0.0%	0.0%	100.0%	0.0%	0.0%	100.0%	0.0%	0.0%
Trucks	0	0	0	0	0	0	0	0	0	0	0	0	0	0	0	0	0	0
% Trucks	0.0%	0.0%	0.0%	0.0%	0.0%	0.0%	0.0%	0.0%	0.0%	0.0%	0.0%	0.0%	0.0%	0.0%	0.0%	0.0%	0.0%	0.0%
Buses	0	7	0	7	0	0	0	0	0	0	0	0	0	0	0	0	0	0
% Buses	0.0%	6.2%	0.0%	0.0%	0.0%	0.0%	0.0%	0.0%	0.0%	0.0%	0.0%	0.0%	0.0%	0.0%	0.0%	0.0%	0.0%	0.0%
Pedestrians	0	0	0	0	0	0	0	0	0	0	0	0	0	0	0	0	1	0
% Pedestrians	0.0%	0.0%	0.0%	0.0%	0.0%	0.0%	0.0%	0.0%	0.0%	0.0%	0.0%	0.0%	0.0%	0.0%	0.0%	0.0%	100.0%	0.0%
Bicycles on Crosswalk	0	0	0	0	0	0	0	0	0	0	0	0	0	0	0	0	0	0
% Bicycles on Crosswalk	0.0%	0.0%	0.0%	0.0%	0.0%	0.0%	0.0%	0.0%	0.0%	0.0%	0.0%	0.0%	0.0%	0.0%	0.0%	0.0%	0.0%	0.0%

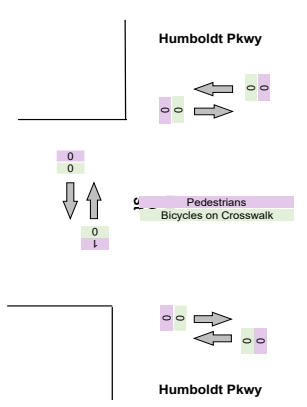
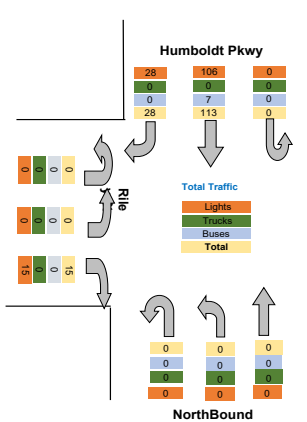

Turning Movement Peak Hour Data (PM)

4:15:00 PM

Leg Direction	Humboldt Pkwy Southbound						Humboldt Pkwy NorthBound						Riley St Eastbound					
	Right	Thru	U-Turn	App Total	Peds CW	Peds CCW	Thru	Left	U-Turn	App Total	Peds CW	Peds CCW	Right	Left	U-Turn	App Total	Peds CW	Peds CCW
4:15:00 PM	2	44	0	46	0	0	0	0	0	0	0	0	4	0	0	4	0	0
4:30:00 PM	8	47	0	55	0	0	0	0	0	0	0	0	6	0	0	6	0	0
4:45:00 PM	8	37	0	45	0	0	0	0	0	0	0	0	2	0	0	2	0	1
5:00:00 PM	13	30	0	43	0	0	0	0	0	0	0	0	4	0	0	4	0	0
Grand Total	31	158	0	189	0	0	0	0	0	0	0	0	16	0	0	16	0	1
% Approach	16.4%	83.6%	0.0%	0.0%	0.0%	0.0%	14.2%	0.0%	0.0%	0.0%	0.0%	0.0%	45.1%	41.7%	0.0%	0.0%	0.0%	0.0%
% Total	15.1%	77.1%	0.0%	92.2%	0.0%	0.0%	0.0%	0.0%	0.0%	0.0%	0.0%	0.0%	7.8%	0.0%	0.0%	7.8%	0.0%	0.0%
PHF	0.596	0.840	0.000	0.859	0.000	0.000	0.000	0.000	0.000	0.000	0.000	0.000	0.667	0.000	0.000	0.667	0.000	0.000
Lights	29	147	0	176	0	0	0	0	0	0	0	0	16	0	0	16	0	0
% Lights	93.5%	93.0%	0.0%	93.1%	0.0%	0.0%	0.0%	0.0%	0.0%	0.0%	0.0%	0.0%	100.0%	0.0%	0.0%	100.0%	0.0%	0.0%
Trucks	0	0	0	0	0	0	0	0	0	0	0	0	0	0	0	0	0	0
% Trucks	0.0%	0.0%	0.0%	0.0%	0.0%	0.0%	0.0%	0.0%	0.0%	0.0%	0.0%	0.0%	0.0%	0.0%	0.0%	0.0%	0.0%	0.0%
Buses	2	10	0	12	0	0	0	0	0	0	0	0	0	0	0	0	0	0
% Buses	6.5%	6.3%	0.0%	6.0%	0.0%	0.0%	0.0%	0.0%	0.0%	0.0%	0.0%	0.0%	0.0%	0.0%	0.0%	0.0%	0.0%	0.0%
Pedestrians	0	0	0	0	0	0	0	0	0	0	0	0	0	0	0	0	0	1
% Pedestrians	0.0%	0.0%	0.0%	0.0%	0.0%	0.0%	0.0%	0.0%	0.0%	0.0%	0.0%	0.0%	0.0%	0.0%	0.0%	0.0%	0.0%	100.0%
Bicycles on Crosswalk	0	0	0	0	0	0	0	0	0	0	0	0	0	0	0	0	0	0
% Bicycles on Crosswalk	0.0%	0.0%	0.0%	0.0%	0.0%	0.0%	0.0%	0.0%	0.0%	0.0%	0.0%	0.0%	0.0%	0.0%	0.0%	0.0%	0.0%	0.0%

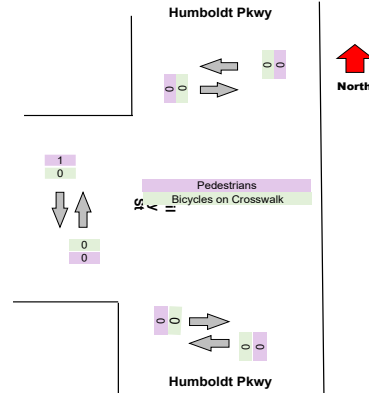
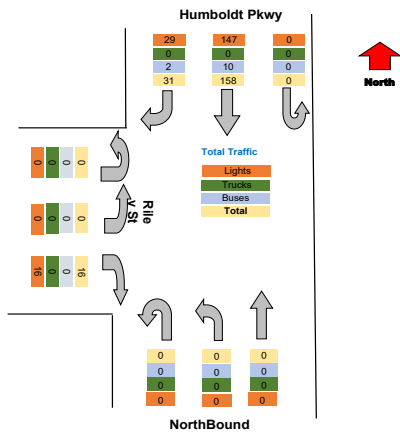

Intersection: Elm St Pine St
 Location: Kennett Square, PA
 Site: 01
 Survey Date: Wednesday, 04-28-2021
 GPS: 42.948550, -72.790034



Total
12
31
43
22
23
21
43
109
45
47
92
56
50
61
47
214
47
50
49
41
187
645
0.0%
0.0%
609
94.4%
0
0.0%
34
5.3%
0
0.0%
0.0%

Intersection: Elm St Pine St
Location: Kennett Square, PA
Site: 01
Survey Date: Wednesday, 04-28-2021
GPS: 42.948550, -72.790034

Total
21
43
45
47
156
0.830
149
95.5%
0
0.0%
7
4.5%
0
0.0%
0
0.0%

Intersection: Elm St Pine St
Location: Kennett Square, PA
Site: 01
Survey Date: Wednesday, 04-28-2021
GPS: 42.948550, -72.790034



Total
50
61
47
47
205
0.840
192
93.7%
0
0.0%
12
5.9%
0
0.0%
0
0.0%

Project	Labella
Project Code	Labella
Site Name	C
Legs and Movements	All Processed Legs & Movements
Bin Size	15 minutes
Survey Date	2021-10-28, Thursday
Location	C
Latitude and Longitude	42.909273, -78.843749

	Start	End	PHF
Forced Peak AM	2021/10/28 07:30:00	2021/10/28 08:30:00	0.738
Forced Peak PM	2021/10/28 16:30:00	2021/10/28 17:30:00	0.938
AM Peak	2021/10/28 07:30:00	2021/10/28 08:30:00	0.738
PM Peak	2021/10/28 16:15:00	2021/10/28 17:15:00	0.828

Turning Movement Data

Leg Direction	Humboldt Pkwy Southbound						Humboldt Pkwy NorthBound						Riley St Eastbound															
	Right	Thru	U-Turn	App	Total	Peds	CW	Peds	CCW	Thru	Left	U-Turn	App	Total	Peds	CW	Peds	CCW	Right	Left	U-Turn	App	Total	Peds	CW	Peds	CCW	
Start Time																												
6:30:00 AM	2	11	0	13	0	0	0	0	0	0	0	0	0	0	0	0	0	0	2	0	0	2	0	0	0	0	0	
6:45:00 AM	4	17	0	21	0	0	0	0	0	0	0	0	0	0	0	0	0	0	1	0	0	1	0	0	0	0	0	
Hourly Total	6	28	0	34	0	0	0	0	0	0	0	0	0	0	0	0	0	0	3	0	0	3	0	0	0	0	0	
7:00:00 AM	1	12	0	13	0	0	0	0	0	0	0	0	0	0	0	0	0	0	3	0	0	3	0	0	0	1	0	
7:15:00 AM	6	19	0	25	0	0	0	0	0	0	0	0	0	0	0	0	0	0	1	0	0	1	0	0	0	0	0	
7:30:00 AM	4	21	0	25	0	0	0	0	0	0	0	0	0	0	0	0	0	0	2	0	0	2	0	0	0	0	0	
7:45:00 AM	9	49	0	58	0	0	0	0	0	0	0	0	0	0	0	0	0	0	2	0	0	2	0	0	0	0	0	
Hourly Total	20	101	0	121	0	0	0	0	0	0	0	0	0	0	0	0	0	0	8	0	0	8	0	0	1	0	1	
8:00:00 AM	5	33	0	38	0	0	0	0	0	0	0	0	0	0	0	0	0	0	5	0	0	5	0	0	0	0	0	
8:15:00 AM	7	38	0	45	0	0	0	0	0	0	0	0	0	0	0	0	0	0	2	0	0	2	0	0	0	0	0	
Hourly Total	12	71	0	83	0	0	0	0	0	0	0	0	0	0	0	0	0	0	7	0	0	7	0	0	0	0	0	
4:00:00 PM	2	47	0	49	0	0	0	0	0	0	0	0	0	0	0	0	0	0	6	0	0	6	0	0	2	0	2	
4:15:00 PM	9	48	0	57	0	0	0	0	0	0	0	0	0	0	0	0	0	0	7	0	0	7	3	0	0	0	0	
4:30:00 PM	8	41	0	49	0	0	0	0	0	0	0	0	0	0	0	0	0	0	3	0	0	3	0	0	1	0	1	
4:45:00 PM	10	27	0	37	0	0	0	0	0	0	0	0	0	0	0	0	0	0	7	0	0	7	0	0	0	0	0	
Hourly Total	29	163	0	192	0	0	0	0	0	0	0	0	0	0	0	0	0	0	23	0	0	23	3	0	3	0	3	
5:00:00 PM	3	39	0	42	0	0	0	0	0	0	0	0	0	0	0	0	0	0	10	0	0	10	1	0	1	0	1	
5:15:00 PM	10	35	0	45	0	0	0	0	0	0	0	0	0	0	0	0	0	0	2	0	0	2	1	0	0	0	0	
5:30:00 PM	7	40	0	47	0	0	0	0	0	0	0	0	0	0	0	0	0	0	3	0	0	3	0	0	1	0	1	
5:45:00 PM	4	32	0	36	0	0	0	0	0	0	0	0	0	0	0	0	0	0	3	0	0	3	0	0	1	0	1	
Hourly Total	24	146	0	170	0	0	0	0	0	0	0	0	0	0	0	0	0	0	18	0	0	18	2	0	3	0	3	
Grand Total	91	509	0	600	0	0	0	0	0	0	0	0	0	0	0	0	0	0	59	0	0	59	5	0	7	0	7	
% Approach	15.2%	84.8%	0.0%	0.0%	0.0%	0.0%	0.0%	0.0%	0.0%	0.0%	0.0%	0.0%	0.0%	0.0%	0.0%	0.0%	0.0%	0.0%	100.0%	0.0%	0.0%	0.0%	0.0%	0.0%	0.0%	0.0%	0.0%	
% Total	13.8%	77.2%	0.0%	91.0%	0.0%	0.0%	0.0%	0.0%	0.0%	0.0%	0.0%	0.0%	0.0%	0.0%	0.0%	0.0%	0.0%	0.0%	9.0%	0.0%	0.0%	9.0%	0.0%	0.0%	0.0%	0.0%	0.0%	
Lights	87	476	0	563	0	0	0	0	0	0	0	0	0	0	0	0	0	0	59	0	0	59	0	0	0	0	0	
% Lights	95.6%	93.5%	0.0%	93.8%	0.0%	0.0%	0.0%	0.0%	0.0%	0.0%	0.0%	0.0%	0.0%	0.0%	0.0%	0.0%	0.0%	0.0%	100.0%	0.0%	0.0%	100.0%	0.0%	0.0%	0.0%	0.0%	0.0%	
Trucks	0	0	0	0	0	0	0	0	0	0	0	0	0	0	0	0	0	0	0	0	0	0	0	0	0	0	0	
% Trucks	0.0%	0.0%	0.0%	0.0%	0.0%	0.0%	0.0%	0.0%	0.0%	0.0%	0.0%	0.0%	0.0%	0.0%	0.0%	0.0%	0.0%	0.0%	0.0%	0.0%	0.0%	0.0%	0.0%	0.0%	0.0%	0.0%	0.0%	
Buses	4	32	0	36	0	0	0	0	0	0	0	0	0	0	0	0	0	0	0	0	0	0	0	0	0	0	0	
% Buses	4.4%	6.3%	0.0%	6.0%	0.0%	0.0%	0.0%	0.0%	0.0%	0.0%	0.0%	0.0%	0.0%	0.0%	0.0%	0.0%	0.0%	0.0%	0.0%	0.0%	0.0%	0.0%	0.0%	0.0%	0.0%	0.0%	0.0%	
Pedestrians	0	0	0	0	0	0	0	0	0	0	0	0	0	0	0	0	0	0	0	0	0	0	4	0	6	0	6	
% Pedestrians	0.0%	0.0%	0.0%	0.0%	0.0%	0.0%	0.0%	0.0%	0.0%	0.0%	0.0%	0.0%	0.0%	0.0%	0.0%	0.0%	0.0%	0.0%	0.0%	0.0%	0.0%	0.0%	6.7%	0.0%	8.3%	0.0%	8.7%	
% Bicycles on Crosswalk	0.0%	0.0%	0.0%	0.0%	0.0%	0.0%	0.0%	0.0%	0.0%	0.0%	0.0%	0.0%	0.0%	0.0%	0.0%	0.0%	0.0%	0.0%	0.0%	0.0%	0.0%	0.0%	20.0%	0.0%	14.3%	0.0%	14.3%	

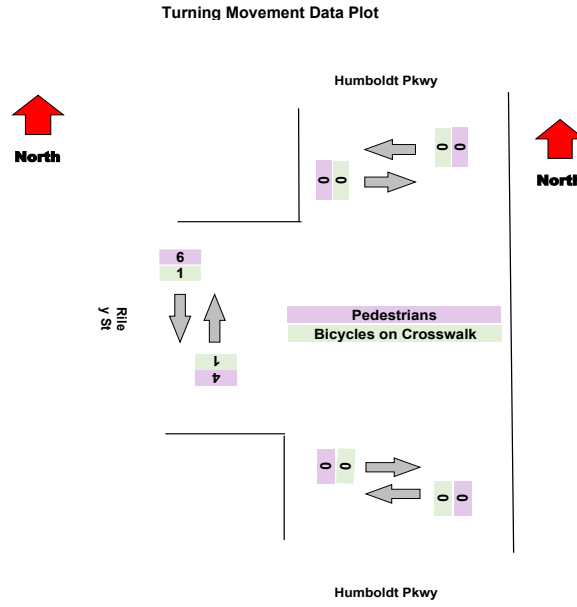
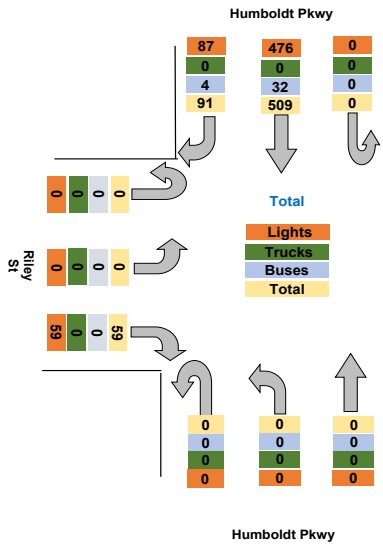

Turning Movement Peak Hour Data (AM)

7:30:00 AM

Leg Direction	Humboldt Pkwy Southbound						Humboldt Pkwy NorthBound						Riley St Eastbound					
	Right	Thru	U-Turn	App Total	Peds CW	Peds CCW	Thru	Left	U-Turn	App Total	Peds CW	Peds CCW	Right	Left	U-Turn	App Total	Peds CW	Peds CCW
7:30:00 AM	4	21	0	25	0	0	0	0	0	0	0	0	2	0	0	2	0	0
7:45:00 AM	9	49	0	58	0	0	0	0	0	0	0	0	2	0	0	2	0	0
8:00:00 AM	5	33	0	38	0	0	0	0	0	0	0	0	5	0	0	5	0	0
8:15:00 AM	7	38	0	45	0	0	0	0	0	0	0	0	2	0	0	2	0	0
Grand Total	25	141	0	166	0	0	0	0	0	0	0	0	11	0	0	11	0	0
% Approach	15.1%	84.9%	0.0%	0.0%	0.0%	0.0%	14.2%	0.0%	0.0%	0.0%	0.0%	0.0%	45.1%	41.7%	0.0%	0.0%	0.0%	0.0%
% Total	14.1%	79.7%	0.0%	93.8%	0.0%	0.0%	0.0%	0.0%	0.0%	0.0%	0.0%	0.0%	6.2%	0.0%	0.0%	6.2%	0.0%	0.0%
PHF	0.694	0.719	0.000	0.716	0.000	0.000	0.000	0.000	0.000	0.000	0.000	0.000	0.550	0.000	0.000	0.550	0.000	0.000
Lights	25	131	0	156	0	0	0	0	0	0	0	0	11	0	0	11	0	0
% Lights	100.0%	92.9%	0.0%	94.0%	0.0%	0.0%	0.0%	0.0%	0.0%	0.0%	0.0%	0.0%	100.0%	0.0%	0.0%	100.0%	0.0%	0.0%
Trucks	0	0	0	0	0	0	0	0	0	0	0	0	0	0	0	0	0	0
% Trucks	0.0%	0.0%	0.0%	0.0%	0.0%	0.0%	0.0%	0.0%	0.0%	0.0%	0.0%	0.0%	0.0%	0.0%	0.0%	0.0%	0.0%	0.0%
Buses	0	10	0	10	0	0	0	0	0	0	0	0	0	0	0	0	0	0
% Buses	0.0%	7.1%	0.0%	0.0%	0.0%	0.0%	0.0%	0.0%	0.0%	0.0%	0.0%	0.0%	0.0%	0.0%	0.0%	0.0%	0.0%	0.0%
Pedestrians	0	0	0	0	0	0	0	0	0	0	0	0	0	0	0	0	0	0
% Pedestrians	0.0%	0.0%	0.0%	0.0%	0.0%	0.0%	0.0%	0.0%	0.0%	0.0%	0.0%	0.0%	0.0%	0.0%	0.0%	0.0%	0.0%	0.0%
Bicycles on Crosswalk	0	0	0	0	0	0	0	0	0	0	0	0	0	0	0	0	0	0
% Bicycles on Crosswalk	0.0%	0.0%	0.0%	0.0%	0.0%	0.0%	0.0%	0.0%	0.0%	0.0%	0.0%	0.0%	0.0%	0.0%	0.0%	0.0%	0.0%	0.0%

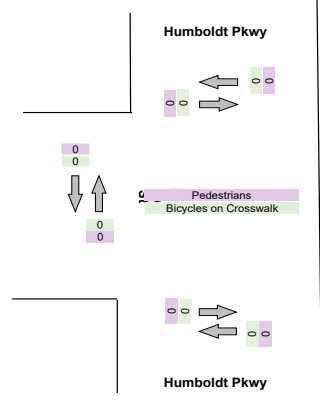
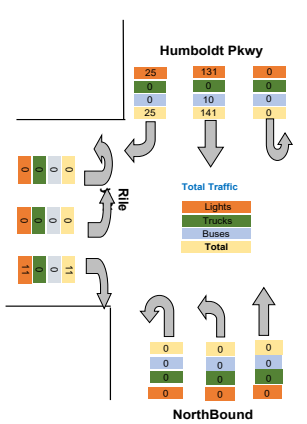

Turning Movement Peak Hour Data (PM)

4:15:00 PM

Leg Direction	Humboldt Pkwy Southbound						Humboldt Pkwy NorthBound						Riley St Eastbound					
	Right	Thru	U-Turn	App Total	Peds CW	Peds CCW	Thru	Left	U-Turn	App Total	Peds CW	Peds CCW	Right	Left	U-Turn	App Total	Peds CW	Peds CCW
4:15:00 PM	9	48	0	57	0	0	0	0	0	0	0	0	7	0	0	7	3	0
4:30:00 PM	8	41	0	49	0	0	0	0	0	0	0	0	3	0	0	3	0	1
4:45:00 PM	10	27	0	37	0	0	0	0	0	0	0	0	7	0	0	7	0	0
5:00:00 PM	3	39	0	42	0	0	0	0	0	0	0	0	10	0	0	10	1	1
Grand Total	30	155	0	185	0	0	0	0	0	0	0	0	27	0	0	27	4	2
% Approach	16.2%	83.8%	0.0%	0.0%	0.0%	0.0%	14.2%	0.0%	0.0%	0.0%	0.0%	0.0%	45.1%	41.7%	0.0%	0.0%	0.0%	0.0%
% Total	14.2%	73.1%	0.0%	87.3%	0.0%	0.0%	0.0%	0.0%	0.0%	0.0%	0.0%	0.0%	12.7%	0.0%	0.0%	12.7%	0.0%	0.0%
PHF	0.750	0.807	0.000	0.811	0.000	0.000	0.000	0.000	0.000	0.000	0.000	0.000	0.675	0.000	0.000	0.675	0.000	0.000
Lights	29	145	0	174	0	0	0	0	0	0	0	0	27	0	0	27	0	0
% Lights	96.7%	93.5%	0.0%	94.1%	0.0%	0.0%	0.0%	0.0%	0.0%	0.0%	0.0%	0.0%	100.0%	0.0%	0.0%	100.0%	0.0%	0.0%
Trucks	0	0	0	0	0	0	0	0	0	0	0	0	0	0	0	0	0	0
% Trucks	0.0%	0.0%	0.0%	0.0%	0.0%	0.0%	0.0%	0.0%	0.0%	0.0%	0.0%	0.0%	0.0%	0.0%	0.0%	0.0%	0.0%	0.0%
Buses	1	9	0	10	0	0	0	0	0	0	0	0	0	0	0	0	0	0
% Buses	3.3%	5.8%	0.0%	0.0%	0.0%	0.0%	0.0%	0.0%	0.0%	0.0%	0.0%	0.0%	0.0%	0.0%	0.0%	0.0%	0.0%	0.0%
Pedestrians	0	0	0	0	0	0	0	0	0	0	0	0	0	0	0	0	3	1
% Pedestrians	0.0%	0.0%	0.0%	0.0%	0.0%	0.0%	0.0%	0.0%	0.0%	0.0%	0.0%	0.0%	0.0%	0.0%	0.0%	0.0%	75.0%	50.0%
Bicycles on Crosswalk	0	0	0	0	0	0	0	0	0	0	0	0	0	0	0	0	1	1
% Bicycles on Crosswalk	0.0%	0.0%	0.0%	0.0%	0.0%	0.0%	0.0%	0.0%	0.0%	0.0%	0.0%	0.0%	0.0%	0.0%	0.0%	0.0%	25.0%	50.0%

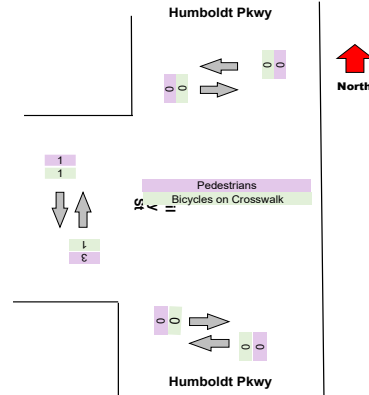
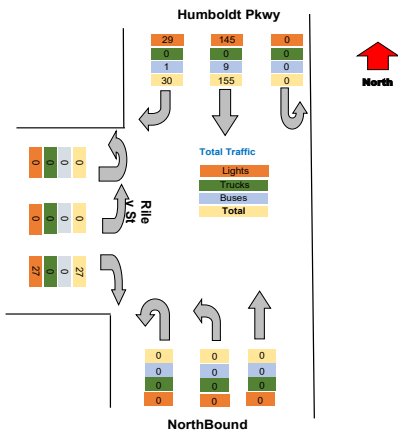

Intersection: Elm St Pine St
 Location: Kennett Square, PA
 Site: 01
 Survey Date: Wednesday, 04-28-2021
 GPS: 42.948550, -72.790034



Total
15
22
37
16
26
27
60
129
43
47
90
55
64
52
44
215
52
47
50
39
188
659
0.0%
0.0%
622
94.4%
0
0.0%
36
5.5%
0
0.0%
0.0%

Intersection: Elm St Pine St
Location: Kennett Square, PA
Site: 01
Survey Date: Wednesday, 04-28-2021
GPS: 42.948550, -72.790034



Total
27
60
43
47
177
0.738
167
94.4%
0
0.0%
10
5.6%
0
0.0%
0
0.0%

Intersection: Elm St Pine St
Location: Kennett Square, PA
Site: 01
Survey Date: Wednesday, 04-28-2021
GPS: 42.948550, -72.790034



Total
64
52
44
52
212
0.828
201
94.8%
0
0.0%
10
4.7%
0
0.0%
0
0.0%

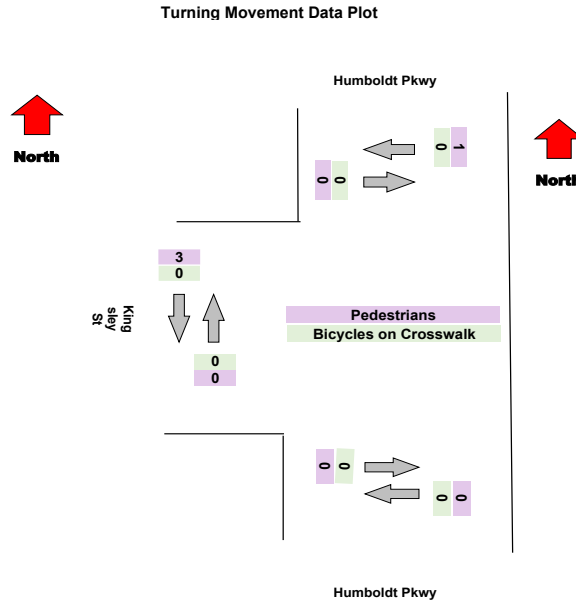
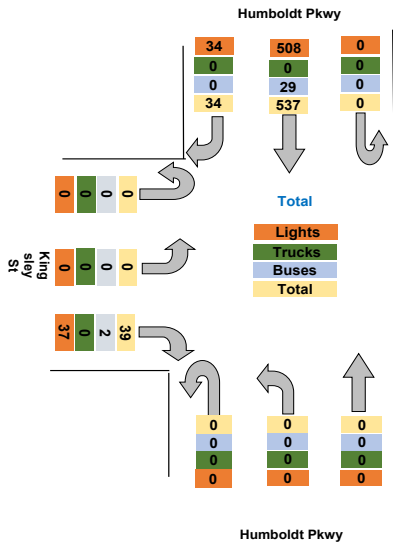

Turning Movement Peak Hour Data (AM)

7:30:00 AM

Leg Direction	Humboldt Pkwy Southbound						Humboldt Pkwy NorthBound						Kingsley St Eastbound					
	Right	Thru	U-Turn	App Total	Peds CW	Peds CCW	Thru	Left	U-Turn	App Total	Peds CW	Peds CCW	Right	Left	U-Turn	App Total	Peds CW	Peds CCW
Start Time	7:30:00 AM	2	28	0	30	0	0	0	0	0	0	0	4	0	0	4	0	0
	7:45:00 AM	2	31	0	33	0	0	0	0	0	0	0	3	0	0	3	0	0
	8:00:00 AM	1	28	0	29	0	1	0	0	1	0	0	2	0	0	2	0	0
	8:15:00 AM	4	28	0	32	0	0	0	0	0	0	0	3	0	0	3	0	0
Grand Total		9	115	0	124	0	1	0	0	1	0	0	12	0	0	12	0	0
% Approach		7.3%	92.7%	0.0%	0.0%	0.0%	14.2%	0.0%	0.0%	0.0%	0.0%	45.1%	41.7%	0.0%	0.0%	0.0%	0.0%	0.0%
% Total		6.6%	83.9%	0.0%	90.5%	0.0%	0.0%	0.0%	0.0%	0.7%	0.0%	0.0%	8.8%	0.0%	0.0%	8.8%	0.0%	0.0%
PHF		0.563	0.927	0.000	0.939	0.000	0.000	0.000	0.000	0.250	0.000	0.000	0.750	0.000	0.000	0.750	0.000	0.000
Lights		9	107	0	116	0	0	0	0	0	0	0	11	0	0	11	0	0
% Lights		100.0%	93.0%	0.0%	93.5%	0.0%	0.0%	0.0%	0.0%	0.0%	0.0%	0.0%	91.7%	0.0%	0.0%	91.7%	0.0%	0.0%
Trucks		0	0	0	0	0	0	0	0	0	0	0	0	0	0	0	0	0
% Trucks		0.0%	0.0%	0.0%	0.0%	0.0%	0.0%	0.0%	0.0%	0.0%	0.0%	0.0%	0.0%	0.0%	0.0%	0.0%	0.0%	0.0%
Buses		0	8	0	8	0	0	0	0	0	0	0	1	0	0	1	0	0
% Buses		0.0%	7.0%	0.0%	0.0%	0.0%	0.0%	0.0%	0.0%	0.0%	0.0%	0.0%	8.3%	0.0%	0.0%	0.0%	0.0%	0.0%
Pedestrians		0	0	0	0	1	0	0	0	0	0	0	0	0	0	0	0	0
% Pedestrians		0.0%	0.0%	0.0%	0.0%	100.0%	0.0%	0.0%	0.0%	0.0%	0.0%	0.0%	0.0%	0.0%	0.0%	0.0%	0.0%	0.0%
Bicycles on Crosswalk		0	0	0	0	0	0	0	0	0	0	0	0	0	0	0	0	0
% Bicycles on Crosswalk		0.0%	0.0%	0.0%	0.0%	0.0%	0.0%	0.0%	0.0%	0.0%	0.0%	0.0%	0.0%	0.0%	0.0%	0.0%	0.0%	0.0%

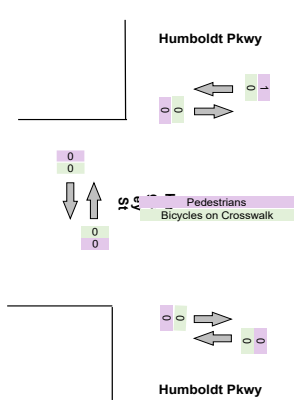
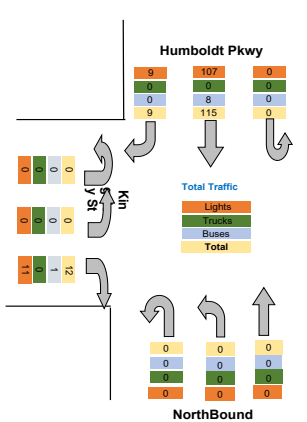

Turning Movement Peak Hour Data (PM)

4:15:00 PM

Leg Direction	Humboldt Pkwy Southbound						Humboldt Pkwy NorthBound						Kingsley St Eastbound					
	Right	Thru	U-Turn	App Total	Peds CW	Peds CCW	Thru	Left	U-Turn	App Total	Peds CW	Peds CCW	Right	Left	U-Turn	App Total	Peds CW	Peds CCW
4:15:00 PM	0	50	0	50	0	0	0	0	0	0	0	0	5	0	0	5	0	0
4:30:00 PM	0	49	0	49	0	0	0	0	0	0	0	0	3	0	0	3	0	1
4:45:00 PM	3	47	0	50	0	0	0	0	0	0	0	0	3	0	0	3	0	0
5:00:00 PM	1	39	0	40	0	0	0	0	0	0	0	0	1	0	0	1	0	1
Grand Total	4	185	0	189	0	0	0	0	0	0	0	0	12	0	0	12	0	2
% Approach	2.1%	97.9%	0.0%	0.0%	0.0%	0.0%	14.2%	0.0%	0.0%	0.0%	0.0%	0.0%	45.1%	41.7%	0.0%	0.0%	0.0%	0.0%
% Total	2.0%	92.0%	0.0%	94.0%	0.0%	0.0%	0.0%	0.0%	0.0%	0.0%	0.0%	0.0%	6.0%	0.0%	0.0%	6.0%	0.0%	0.0%
PHF	0.333	0.925	0.000	0.945	0.000	0.000	0.000	0.000	0.000	0.000	0.000	0.000	0.600	0.000	0.000	0.600	0.000	0.000
Lights	4	176	0	180	0	0	0	0	0	0	0	0	11	0	0	11	0	0
% Lights	100.0%	95.1%	0.0%	95.2%	0.0%	0.0%	0.0%	0.0%	0.0%	0.0%	0.0%	0.0%	91.7%	0.0%	0.0%	91.7%	0.0%	0.0%
Trucks	0	0	0	0	0	0	0	0	0	0	0	0	0	0	0	0	0	0
% Trucks	0.0%	0.0%	0.0%	0.0%	0.0%	0.0%	0.0%	0.0%	0.0%	0.0%	0.0%	0.0%	0.0%	0.0%	0.0%	0.0%	0.0%	0.0%
Buses	0	9	0	9	0	0	0	0	0	0	0	0	1	0	0	1	0	0
% Buses	0.0%	4.9%	0.0%	0.0%	0.0%	0.0%	0.0%	0.0%	0.0%	0.0%	0.0%	0.0%	8.3%	0.0%	0.0%	0.0%	0.0%	0.0%
Pedestrians	0	0	0	0	0	0	0	0	0	0	0	0	0	0	0	0	0	2
% Pedestrians	0.0%	0.0%	0.0%	0.0%	0.0%	0.0%	0.0%	0.0%	0.0%	0.0%	0.0%	0.0%	0.0%	0.0%	0.0%	0.0%	0.0%	100.0%
Bicycles on Crosswalk	0	0	0	0	0	0	0	0	0	0	0	0	0	0	0	0	0	0
% Bicycles on Crosswalk	0.0%	0.0%	0.0%	0.0%	0.0%	0.0%	0.0%	0.0%	0.0%	0.0%	0.0%	0.0%	0.0%	0.0%	0.0%	0.0%	0.0%	0.0%

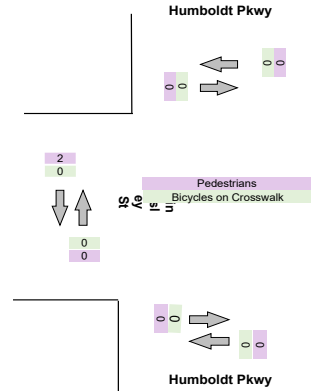
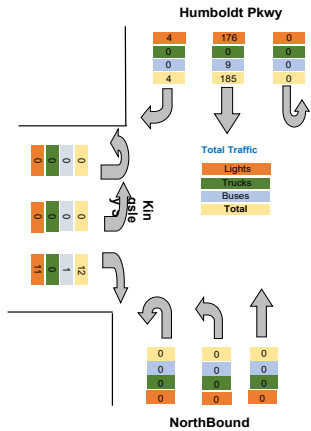

Intersection: Elm St Pine St
 Location: Kennett Square, PA
 Site: 01
 Survey Date: Wednesday, 04-28-2021
 GPS: 42.948550, -72.790034



Total
21
26
47
20
17
34
36
107
32
35
67
64
55
52
53
224
41
43
48
34
166
611
0.0%
0.0%
579
94.8%
0
0.0%
31
5.1%
0
0.0%
0.0%

Intersection: Elm St Pine St
Location: Kennett Square, PA
Site: 01
Survey Date: Wednesday, 04-28-2021
GPS: 42.948550, -72.790034



Total
34
36
32
35
137
0.951
127
92.7%
0
0.0%
9
6.6%
0
0.0%
0
0.0%

Intersection: Elm St Pine St
Location: Kennett Square, PA
Site: 01
Survey Date: Wednesday, 04-28-2021
GPS: 42.948550, -72.790034



Total
55
52
53
41
201
0.914
191
95.0%
0
0.0%
10
5.0%
0
0.0%
0
0.0%

Project	Labella
Project Code	Labella
Site Name	D
Legs and Movements	All Processed Legs & Movements
Bin Size	15 minutes
Survey Date	2021-10-27, Wednesday
Location	D
Latitude and Longitude	42.908145, -78.843950

	Start	End	PHF
Forced Peak AM	2021/10/27 07:30:00	2021/10/27 08:30:00	0.815
Forced Peak PM	2021/10/27 16:30:00	2021/10/27 17:30:00	0.826
AM Peak	2021/10/27 07:30:00	2021/10/27 08:30:00	0.815
PM Peak	2021/10/27 16:15:00	2021/10/27 17:15:00	0.871

Turning Movement Data

Leg Direction	Humboldt Pkwy Southbound						Humboldt Pkwy Northbound						Kingsley St Eastbound														
	Right	Thru	U-Turn	App	Total	Peds	CW	Peds	CCW	Thru	Left	U-Turn	App	Total	Peds	CW	Peds	CCW	Right	Left	U-Turn	App	Total	Peds	CW	Peds	CCW
6:30:00 AM	1	9	0	10	0	0	0	0	0	0	0	0	0	0	0	0	0	0	1	0	0	1	0	0	0	0	0
6:45:00 AM	2	22	0	24	0	0	0	0	0	0	0	0	0	0	0	0	0	0	1	0	0	1	0	0	0	0	0
Hourly Total	3	31	0	34	0	0	0	0	0	0	0	0	0	0	0	0	0	2	0	0	2	0	0	0	0	0	
7:00:00 AM	0	18	0	18	0	2	0	0	0	0	0	2	0	0	0	0	0	0	0	0	0	0	0	0	0	1	0
7:15:00 AM	1	18	0	19	0	0	0	0	0	0	0	0	0	0	0	0	0	0	3	0	0	3	0	0	0	0	0
7:30:00 AM	0	14	0	14	0	0	0	0	0	0	0	0	0	0	0	0	0	0	0	0	0	0	0	0	0	0	0
7:45:00 AM	0	40	0	40	0	0	0	0	0	0	0	0	0	0	0	0	0	0	2	0	0	2	1	0	0	0	0
Hourly Total	1	90	0	91	0	2	0	0	0	0	0	2	0	0	0	0	0	5	0	0	5	1	1	1	1	1	
8:00:00 AM	2	37	0	39	0	0	0	0	0	0	0	0	0	0	0	0	0	0	0	0	0	0	1	0	0	0	0
8:15:00 AM	2	34	0	36	0	0	0	0	0	0	0	0	0	0	0	0	0	0	6	0	0	6	0	0	0	0	0
Hourly Total	4	71	0	75	0	0	0	0	0	0	0	0	0	0	0	0	0	6	0	0	6	1	0	0	0	0	
4:00:00 PM	3	46	0	49	0	0	0	0	0	0	0	0	0	0	0	0	0	5	0	0	5	0	0	0	0	0	0
4:15:00 PM	3	47	0	50	0	0	0	0	0	0	0	0	0	0	0	0	0	5	0	0	5	0	0	0	0	0	0
4:30:00 PM	3	49	0	52	0	0	0	0	0	0	0	0	0	0	0	0	0	4	0	0	4	0	0	0	0	0	0
4:45:00 PM	0	36	0	36	0	0	0	0	0	0	0	0	0	0	0	0	0	2	0	0	2	1	1	1	1	1	1
Hourly Total	9	178	0	187	0	0	0	0	0	0	0	0	0	0	0	0	0	16	0	0	16	1	1	1	1	1	
5:00:00 PM	2	37	0	39	0	0	0	0	0	0	0	0	0	0	0	0	0	7	0	0	7	0	0	0	0	0	0
5:15:00 PM	5	35	0	40	0	0	0	0	0	0	0	0	0	0	0	0	0	5	0	0	5	0	1	0	0	1	0
5:30:00 PM	3	42	0	45	0	0	0	0	0	0	0	0	0	0	0	0	0	1	0	0	1	2	0	0	0	0	0
5:45:00 PM	0	31	0	31	0	0	0	0	0	0	0	0	0	0	0	0	0	1	0	0	1	1	2	2	2	2	2
Hourly Total	10	145	0	155	0	0	0	0	0	0	0	0	0	0	0	0	0	14	0	0	14	3	3	3	3	3	
Grand Total	27	515	0	542	0	2	0	0	0	2	0	0	0	0	0	0	0	43	0	0	43	6	5	5	5	5	
% Approach	5.0%	95.0%	0.0%	0.0%	0.0%	0.0%	0.0%	0.0%	0.0%	0.0%	0.0%	0.0%	0.0%	0.0%	0.0%	0.0%	0.0%	100.0%	0.0%	0.0%	0.0%	0.0%	0.0%	0.0%	0.0%	0.0%	0.0%
% Total	4.6%	87.7%	0.0%	92.3%	0.0%	0.0%	0.0%	0.0%	0.0%	0.0%	0.0%	0.3%	0.0%	0.0%	0.0%	0.0%	0.0%	7.3%	0.0%	0.0%	7.3%	0.0%	0.0%	0.0%	0.0%	0.0%	0.0%
Lights	27	483	0	510	0	0	0	0	0	0	0	0	0	0	0	0	0	40	0	0	40	0	0	0	0	0	0
% Lights	100.0%	93.8%	0.0%	94.1%	0.0%	0.0%	0.0%	0.0%	0.0%	0.0%	0.0%	0.0%	0.0%	0.0%	0.0%	0.0%	0.0%	93.0%	0.0%	0.0%	93.0%	0.0%	0.0%	0.0%	0.0%	0.0%	0.0%
Trucks	0	0	0	0	0	0	0	0	0	0	0	0	0	0	0	0	0	0	0	0	0	0	0	0	0	0	0
% Trucks	0.0%	0.0%	0.0%	0.0%	0.0%	0.0%	0.0%	0.0%	0.0%	0.0%	0.0%	0.0%	0.0%	0.0%	0.0%	0.0%	0.0%	0.0%	0.0%	0.0%	0.0%	0.0%	0.0%	0.0%	0.0%	0.0%	0.0%
Buses	0	30	0	30	0	0	0	0	0	0	0	0	0	0	0	0	0	3	0	0	3	0	0	0	0	0	0
% Buses	0.0%	5.8%	0.0%	0.0%	0.0%	0.0%	0.0%	0.0%	0.0%	0.0%	0.0%	0.0%	0.0%	0.0%	0.0%	0.0%	0.0%	7.0%	0.0%	0.0%	0.0%	0.0%	0.0%	0.0%	0.0%	0.0%	0.0%
Pedestrians	0	0	0	0	0	2	0	0	0	0	0	0	0	0	0	0	0	0	0	0	0	0	5	5	5	5	5
% Pedestrians	0.0%	0.0%	0.0%	0.0%	0.0%	100.0%	0.0%	0.0%	0.0%	0.0%	0.0%	0.0%	0.0%	0.0%	0.0%	0.0%	0.0%	0.0%	0.0%	0.0%	0.0%	0.0%	83.3%	100.0%	100.0%	100.0%	100.0%
% Bicycles on Crosswalk	0.0%	0.0%	0.0%	0.0%	0.0%	0.0%	0.0%	0.0%	0.0%	0.0%	0.0%	0.0%	0.0%	0.0%	0.0%	0.0%	0.0%	0.0%	0.0%	0.0%	0.0%	0.0%	16.7%	0.0%	0.0%	0.0%	0.0%

Turning Movement Data Plot

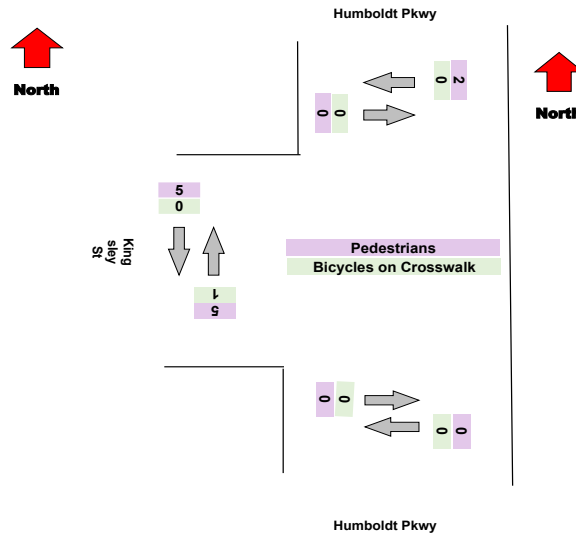
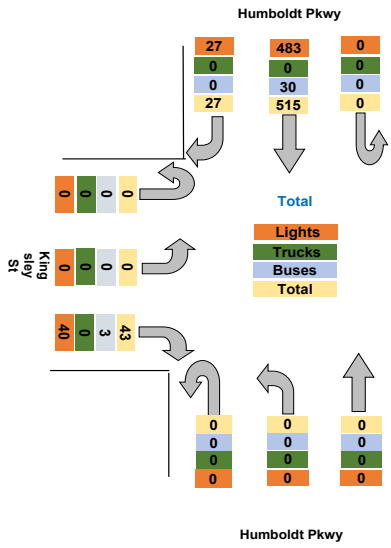

Turning Movement Peak Hour Data (AM)

7:30:00 AM

Leg Direction	Humboldt Pkwy Southbound						Humboldt Pkwy NorthBound						Kingsley St Eastbound					
	Right	Thru	U-Turn	App Total	Peds CW	Peds CCW	Thru	Left	U-Turn	App Total	Peds CW	Peds CCW	Right	Left	U-Turn	App Total	Peds CW	Peds CCW
7:30:00 AM	0	14	0	14	0	0	0	0	0	0	0	0	0	0	0	0	0	0
7:45:00 AM	0	40	0	40	0	0	0	0	0	0	0	0	2	0	0	2	1	0
8:00:00 AM	2	37	0	39	0	0	0	0	0	0	0	0	0	0	0	0	1	0
8:15:00 AM	2	34	0	36	0	0	0	0	0	0	0	0	6	0	0	6	0	0
Grand Total	4	125	0	129	0	0	0	0	0	0	0	0	8	0	0	8	2	0
% Approach	3.1%	96.9%	0.0%	0.0%	0.0%	0.0%	14.2%	0.0%	0.0%	0.0%	0.0%	0.0%	45.1%	41.7%	0.0%	0.0%	0.0%	0.0%
% Total	2.9%	91.2%	0.0%	94.2%	0.0%	0.0%	0.0%	0.0%	0.0%	0.0%	0.0%	0.0%	5.8%	0.0%	0.0%	5.8%	0.0%	0.0%
PHF	0.500	0.781	0.000	0.806	0.000	0.000	0.000	0.000	0.000	0.000	0.000	0.000	0.333	0.000	0.000	0.333	0.000	0.000
Lights	4	118	0	122	0	0	0	0	0	0	0	0	6	0	0	6	0	0
% Lights	100.0%	94.4%	0.0%	94.6%	0.0%	0.0%	0.0%	0.0%	0.0%	0.0%	0.0%	0.0%	75.0%	0.0%	0.0%	75.0%	0.0%	0.0%
Trucks	0	0	0	0	0	0	0	0	0	0	0	0	0	0	0	0	0	0
% Trucks	0.0%	0.0%	0.0%	0.0%	0.0%	0.0%	0.0%	0.0%	0.0%	0.0%	0.0%	0.0%	0.0%	0.0%	0.0%	0.0%	0.0%	0.0%
Buses	0	7	0	7	0	0	0	0	0	0	0	0	2	0	0	2	0	0
% Buses	0.0%	5.6%	0.0%	0.0%	0.0%	0.0%	0.0%	0.0%	0.0%	0.0%	0.0%	0.0%	25.0%	0.0%	0.0%	0.0%	0.0%	0.0%
Pedestrians	0	0	0	0	0	0	0	0	0	0	0	0	0	0	0	0	2	0
% Pedestrians	0.0%	0.0%	0.0%	0.0%	0.0%	0.0%	0.0%	0.0%	0.0%	0.0%	0.0%	0.0%	0.0%	0.0%	0.0%	0.0%	100.0%	0.0%
Bicycles on Crosswalk	0	0	0	0	0	0	0	0	0	0	0	0	0	0	0	0	0	0
% Bicycles on Crosswalk	0.0%	0.0%	0.0%	0.0%	0.0%	0.0%	0.0%	0.0%	0.0%	0.0%	0.0%	0.0%	0.0%	0.0%	0.0%	0.0%	0.0%	0.0%

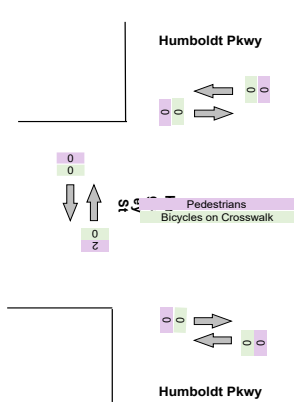
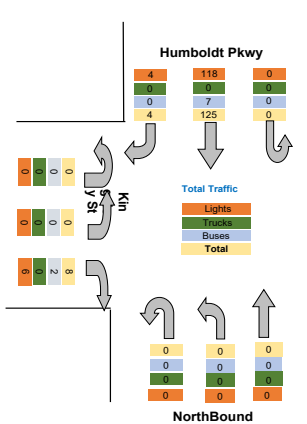

Turning Movement Peak Hour Data (PM)

4:15:00 PM

Leg Direction	Humboldt Pkwy Southbound						Humboldt Pkwy NorthBound						Kingsley St Eastbound					
	Right	Thru	U-Turn	App Total	Peds CW	Peds CCW	Thru	Left	U-Turn	App Total	Peds CW	Peds CCW	Right	Left	U-Turn	App Total	Peds CW	Peds CCW
4:15:00 PM	3	47	0	50	0	0	0	0	0	0	0	0	5	0	0	5	0	0
4:30:00 PM	3	49	0	52	0	0	0	0	0	0	0	0	4	0	0	4	0	0
4:45:00 PM	0	36	0	36	0	0	0	0	0	0	0	0	2	0	0	2	1	1
5:00:00 PM	2	37	0	39	0	0	0	0	0	0	0	0	7	0	0	7	0	0
Grand Total	8	169	0	177	0	0	0	0	0	0	0	0	18	0	0	18	1	1
% Approach	4.5%	95.5%	0.0%	0.0%	0.0%	0.0%	14.2%	0.0%	0.0%	0.0%	0.0%	0.0%	45.1%	41.7%	0.0%	0.0%	0.0%	0.0%
% Total	4.1%	86.7%	0.0%	90.8%	0.0%	0.0%	0.0%	0.0%	0.0%	0.0%	0.0%	0.0%	9.2%	0.0%	0.0%	9.2%	0.0%	0.0%
PHF	0.667	0.862	0.000	0.851	0.000	0.000	0.000	0.000	0.000	0.000	0.000	0.000	0.643	0.000	0.000	0.643	0.000	0.000
Lights	8	158	0	166	0	0	0	0	0	0	0	0	17	0	0	17	0	0
% Lights	100.0%	93.5%	0.0%	93.8%	0.0%	0.0%	0.0%	0.0%	0.0%	0.0%	0.0%	0.0%	94.4%	0.0%	0.0%	94.4%	0.0%	0.0%
Trucks	0	0	0	0	0	0	0	0	0	0	0	0	0	0	0	0	0	0
% Trucks	0.0%	0.0%	0.0%	0.0%	0.0%	0.0%	0.0%	0.0%	0.0%	0.0%	0.0%	0.0%	0.0%	0.0%	0.0%	0.0%	0.0%	0.0%
Buses	0	10	0	10	0	0	0	0	0	0	0	0	0	0	0	1	0	0
% Buses	0.0%	5.9%	0.0%	0.0%	0.0%	0.0%	0.0%	0.0%	0.0%	0.0%	0.0%	0.0%	5.6%	0.0%	0.0%	0.0%	0.0%	0.0%
Pedestrians	0	0	0	0	0	0	0	0	0	0	0	0	0	0	0	0	0	1
% Pedestrians	0.0%	0.0%	0.0%	0.0%	0.0%	0.0%	0.0%	0.0%	0.0%	0.0%	0.0%	0.0%	0.0%	0.0%	0.0%	0.0%	0.0%	100.0%
Bicycles on Crosswalk	0	0	0	0	0	0	0	0	0	0	0	0	0	0	0	0	1	0
% Bicycles on Crosswalk	0.0%	0.0%	0.0%	0.0%	0.0%	0.0%	0.0%	0.0%	0.0%	0.0%	0.0%	0.0%	0.0%	0.0%	0.0%	0.0%	100.0%	0.0%

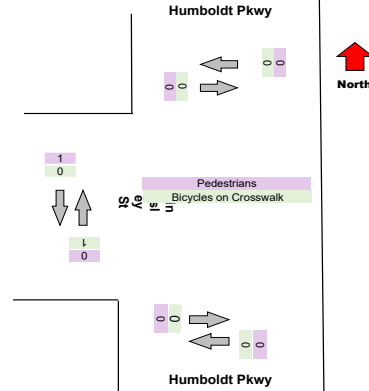
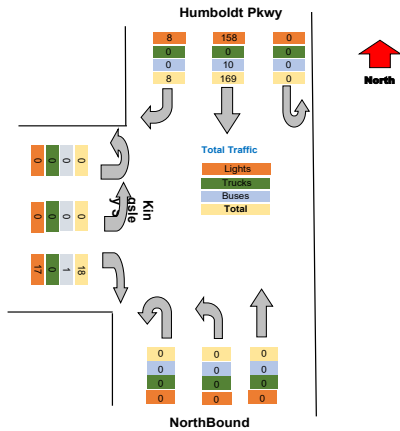

Intersection: Elm St Pine St
 Location: Kennett Square, PA
 Site: 01
 Survey Date: Wednesday, 04-28-2021
 GPS: 42.948550, -72.790034



Total
11
25
36
20
22
14
42
98
39
42
81
54
55
56
38
203
46
45
46
32
169
587
0.0%
0.0%
550
93.7%
0
0.0%
33
5.6%
0
0.0%
0.0%

Intersection: Elm St Pine St
Location: Kennett Square, PA
Site: 01
Survey Date: Wednesday, 04-28-2021
GPS: 42.948550, -72.790034



Total
14
42
39
42
137
0.815
128
93.4%
0
0.0%
9
6.6%
0
0.0%
0
0.0%

Intersection: Elm St Pine St
Location: Kennett Square, PA
Site: 01
Survey Date: Wednesday, 04-28-2021
GPS: 42.948550, -72.790034



Total
55
56
38
46
195
0.871
183
93.8%
0
0.0%
11
5.6%
0
0.0%
0
0.0%

Intersection: Elm St Pine St
 Location: Kennett Square, PA
 Site: 01
 Survey Date: Wednesday, 04-28-2021
 GPS: 42.948550, -72.790034



TSTData.com

Project	Labella
Project Code	Labella
Site Name	D
Legs and Movements	All Processed Legs & Movement
Bin Size	15 minutes
Survey Date	2021-10-28, Thursday
Location	D
Latitude and Longitude	42.908145, -78.843950

	Start	End	PHF
Forced Peak AM	2021/10/28 07:30:00	2021/10/28 08:30:00	0.745
Forced Peak PM	2021/10/28 16:30:00	2021/10/28 17:30:00	0.88
AM Peak	2021/10/28 07:30:00	2021/10/28 08:30:00	0.745
PM Peak	2021/10/28 16:15:00	2021/10/28 17:15:00	0.848

Turning Movement Data

Leg Direction	Humboldt Pkwy Southbound						Humboldt Pkwy Northbound						Kingsley St Eastbound						Total
	Right	Thru	U-Turn	App Total	Peds CW	Peds CCW	Thru	Left	U-Turn	App Total	Peds CW	Peds CCW	Right	Left	U-Turn	App Total	Peds CW	Peds CCW	
6:30:00 AM	0	11	0	11	0	0	0	0	0	0	0	0	1	0	0	1	0	0	12
6:45:00 AM	1	16	0	17	0	0	0	0	0	0	0	0	2	0	0	2	0	0	19
Hourly Total	1	27	0	28	0	0	0	0	0	0	0	0	3	0	0	3	0	0	31
7:00:00 AM	0	16	0	16	0	0	0	0	0	0	0	0	1	0	0	1	0	1	17
7:15:00 AM	0	18	0	18	0	0	0	0	0	0	0	0	1	0	0	1	0	0	19
7:30:00 AM	3	19	0	22	0	0	0	0	0	0	0	0	1	0	0	1	0	0	23
7:45:00 AM	0	52	0	52	0	0	0	0	0	0	0	0	1	0	0	1	0	0	53
Hourly Total	3	105	0	108	0	0	0	0	0	0	0	0	4	0	0	4	0	1	112
8:00:00 AM	0	35	0	35	0	0	0	0	0	0	0	0	1	0	0	1	0	0	36
8:15:00 AM	2	41	0	43	0	0	0	0	0	0	0	0	3	0	0	3	0	0	46
Hourly Total	2	76	0	78	0	0	0	0	0	0	0	0	4	0	0	4	0	0	82
4:00:00 PM	8	44	0	52	0	0	0	0	0	0	0	0	1	0	0	1	0	2	53
4:15:00 PM	3	52	0	55	0	0	0	0	0	0	0	0	1	0	0	1	0	0	56
4:30:00 PM	1	43	0	44	0	0	0	0	0	0	0	0	3	0	0	3	1	0	47
4:45:00 PM	2	33	0	35	0	0	0	0	0	0	0	0	2	0	0	2	0	0	37
Hourly Total	14	172	0	186	0	0	0	0	0	0	0	0	7	0	0	7	1	2	193
5:00:00 PM	4	44	0	48	0	0	0	0	0	0	0	0	2	0	0	2	1	2	50
5:15:00 PM	0	39	0	39	0	0	0	0	0	0	0	0	3	0	0	3	0	0	42
5:30:00 PM	3	39	0	42	0	0	0	0	0	0	0	0	2	0	0	2	2	1	44
5:45:00 PM	3	34	0	37	0	0	0	0	0	0	0	0	2	0	0	2	0	0	39
Hourly Total	10	156	0	166	0	0	0	0	0	0	0	0	9	0	0	9	3	3	175
Grand Total	30	536	0	566	0	0	0	0	0	0	0	0	27	0	0	27	4	5	593
% Approach	5.3%	94.7%	0.0%	0.0%	0.0%	0.0%	0.0%	0.0%	0.0%	0.0%	0.0%	0.0%	###	0.0%	0.0%	0.0%	0.0%	0.0%	0.0%
% Total	5.1%	90.4%	0.0%	95.4%	0.0%	0.0%	0.0%	0.0%	0.0%	0.0%	0.0%	0.0%	4.6%	0.0%	0.0%	4.6%	0.0%	0.0%	0.0%
Lights	29	504	0	533	0	0	0	0	0	0	0	0	25	0	0	25	0	0	558
% Lights	96.7%	94.0%	0.0%	94.2%	0.0%	0.0%	0.0%	0.0%	0.0%	0.0%	0.0%	0.0%	92.6%	0.0%	0.0%	92.6%	0.0%	0.0%	94.1%
Trucks	0	0	0	0	0	0	0	0	0	0	0	0	0	0	0	0	0	0	0
% Trucks	0.0%	0.0%	0.0%	0.0%	0.0%	0.0%	0.0%	0.0%	0.0%	0.0%	0.0%	0.0%	0.0%	0.0%	0.0%	0.0%	0.0%	0.0%	0.0%
Buses	1	31	0	32	0	0	0	0	0	0	0	0	2	0	0	2	0	0	34
% Buses	3.3%	5.8%	0.0%	0.0%	0.0%	0.0%	0.0%	0.0%	0.0%	0.0%	0.0%	0.0%	7.4%	0.0%	0.0%	0.0%	0.0%	0.0%	5.7%
Pedestrians	0	0	0	0	0	0	0	0	0	0	0	0	0	0	0	0	1	5	0
% Pedestrians	0.0%	0.0%	0.0%	0.0%	0.0%	0.0%	0.0%	0.0%	0.0%	0.0%	0.0%	0.0%	0.0%	0.0%	0.0%	0.0%	25.0%	83.3%	0.0%
% Bicycles on Crosswalk	0.0%	0.0%	0.0%	0.0%	0.0%	0.0%	0.0%	0.0%	0.0%	0.0%	0.0%	0.0%	0.0%	0.0%	0.0%	0.0%	75.0%	16.7%	0.0%

Turning Movement Data Plot

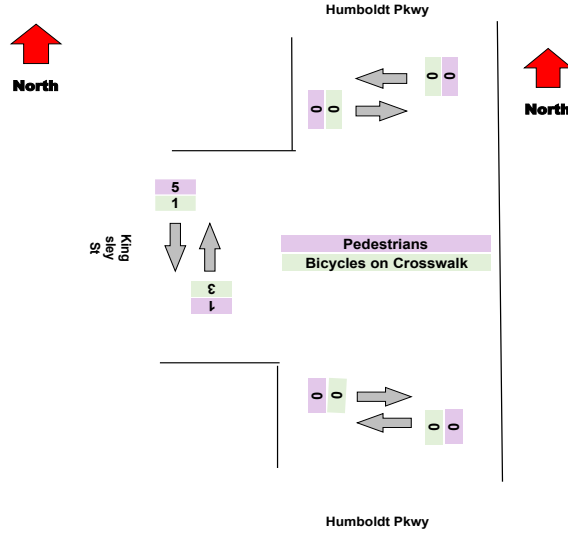
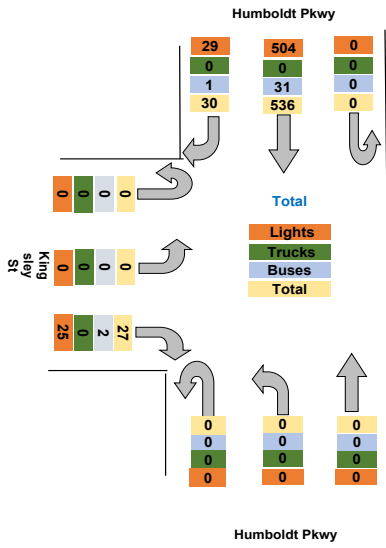

Turning Movement Peak Hour Data (AM)

7:30:00 AM

Leg Direction	Humboldt Pkwy Southbound						Humboldt Pkwy NorthBound						Kingsley St Eastbound						Total
	Right	Thru	U-Turn	App Total	Peds CW	Peds CCW	Thru	Left	U-Turn	App Total	Peds CW	Peds CCW	Right	Left	U-Turn	App Total	Peds CW	Peds CCW	
7:30:00 AM	3	19	0	22	0	0	0	0	0	0	0	0	1	0	0	1	0	0	23
7:45:00 AM	0	52	0	52	0	0	0	0	0	0	0	0	1	0	0	1	0	0	53
8:00:00 AM	0	35	0	35	0	0	0	0	0	0	0	0	1	0	0	1	0	0	36
8:15:00 AM	2	41	0	43	0	0	0	0	0	0	0	0	3	0	0	3	0	0	46
Grand Total	5	147	0	152	0	0	0	0	0	0	0	0	6	0	0	6	0	0	158
% Approach	3.3%	96.7%	0.0%	0.0%	0.0%	0.0%	14.2%	0.0%	0.0%	0.0%	0.0%	0.0%	45.1%	41.7%	0.0%	0.0%	0.0%	0.0%	0.0%
% Total	3.2%	93.0%	0.0%	96.2%	0.0%	0.0%	0.0%	0.0%	0.0%	0.0%	0.0%	0.0%	3.8%	0.0%	0.0%	3.8%	0.0%	0.0%	0.0%
PHF	0.417	0.707	0.000	0.731	0.000	0.000	0.000	0.000	0.000	0.000	0.000	0.000	0.500	0.000	0.000	0.500	0.000	0.000	0.745
Lights	5	137	0	142	0	0	0	0	0	0	0	0	5	0	0	5	0	0	147
% Lights	###	93.2%	0.0%	93.4%	0.0%	0.0%	0.0%	0.0%	0.0%	0.0%	0.0%	0.0%	83.3%	0.0%	0.0%	83.3%	0.0%	0.0%	93.0%
Trucks	0	0	0	0	0	0	0	0	0	0	0	0	0	0	0	0	0	0	0
% Trucks	0.0%	0.0%	0.0%	0.0%	0.0%	0.0%	0.0%	0.0%	0.0%	0.0%	0.0%	0.0%	0.0%	0.0%	0.0%	0.0%	0.0%	0.0%	0.0%
Buses	0	10	0	10	0	0	0	0	0	0	0	0	1	0	0	1	0	0	11
% Buses	0.0%	6.8%	0.0%	6.6%	0.0%	0.0%	0.0%	0.0%	0.0%	0.0%	0.0%	0.0%	16.7%	0.0%	0.0%	16.7%	0.0%	0.0%	7.0%
Pedestrians	0	0	0	0	0	0	0	0	0	0	0	0	0	0	0	0	0	0	0
% Pedestrians	0.0%	0.0%	0.0%	0.0%	0.0%	0.0%	0.0%	0.0%	0.0%	0.0%	0.0%	0.0%	0.0%	0.0%	0.0%	0.0%	0.0%	0.0%	0.0%
Bicycles on Crosswalk	0	0	0	0	0	0	0	0	0	0	0	0	0	0	0	0	0	0	0
% Bicycles on Crosswalk	0.0%	0.0%	0.0%	0.0%	0.0%	0.0%	0.0%	0.0%	0.0%	0.0%	0.0%	0.0%	0.0%	0.0%	0.0%	0.0%	0.0%	0.0%	0.0%

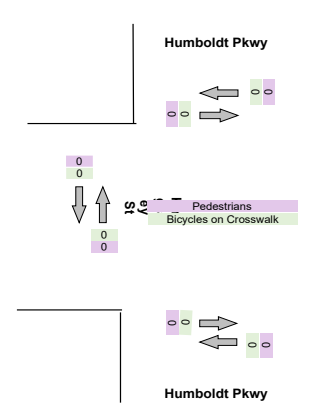
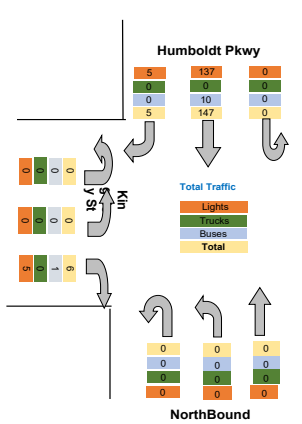

Turning Movement Peak Hour Data (PM)

4:15:00 PM

Leg Direction	Humboldt Pkwy Southbound						Humboldt Pkwy NorthBound						Kingsley St Eastbound						Total
	Right	Thru	U-Turn	App Total	Peds CW	Peds CCW	Thru	Left	U-Turn	App Total	Peds CW	Peds CCW	Right	Left	U-Turn	App Total	Peds CW	Peds CCW	
4:15:00 PM	3	52	0	55	0	0	0	0	0	0	0	0	1	0	0	1	0	0	56
4:30:00 PM	1	43	0	44	0	0	0	0	0	0	0	0	3	0	0	3	1	0	47
4:45:00 PM	2	33	0	35	0	0	0	0	0	0	0	0	2	0	0	2	0	0	37
5:00:00 PM	4	44	0	48	0	0	0	0	0	0	0	0	2	0	0	2	1	2	50
Grand Total	10	172	0	182	0	0	0	0	0	0	0	0	8	0	0	8	2	2	190
% Approach	5.5%	94.5%	0.0%	0.0%	0.0%	0.0%	14.2%	0.0%	0.0%	0.0%	0.0%	0.0%	45.1%	41.7%	0.0%	0.0%	0.0%	0.0%	0.0%
% Total	5.3%	90.5%	0.0%	95.8%	0.0%	0.0%	0.0%	0.0%	0.0%	0.0%	0.0%	0.0%	4.2%	0.0%	0.0%	4.2%	0.0%	0.0%	0.0%
PHF	0.625	0.827	0.000	0.827	0.000	0.000	0.000	0.000	0.000	0.000	0.000	0.000	0.667	0.000	0.000	0.667	0.000	0.000	0.848
Lights	9	163	0	172	0	0	0	0	0	0	0	0	7	0	0	7	0	0	179
% Lights	90.0%	94.8%	0.0%	94.5%	0.0%	0.0%	0.0%	0.0%	0.0%	0.0%	0.0%	0.0%	87.5%	0.0%	0.0%	87.5%	0.0%	0.0%	94.2%
Trucks	0	0	0	0	0	0	0	0	0	0	0	0	0	0	0	0	0	0	0
% Trucks	0.0%	0.0%	0.0%	0.0%	0.0%	0.0%	0.0%	0.0%	0.0%	0.0%	0.0%	0.0%	0.0%	0.0%	0.0%	0.0%	0.0%	0.0%	0.0%
Buses	1	8	0	9	0	0	0	0	0	0	0	0	1	0	0	1	0	0	10
% Buses	10.0%	4.7%	0.0%	0.0%	0.0%	0.0%	0.0%	0.0%	0.0%	0.0%	0.0%	0.0%	12.5%	0.0%	0.0%	0.0%	0.0%	0.0%	5.3%
Pedestrians	0	0	0	0	0	0	0	0	0	0	0	0	0	0	0	0	1	1	0
% Pedestrians	0.0%	0.0%	0.0%	0.0%	0.0%	0.0%	0.0%	0.0%	0.0%	0.0%	0.0%	0.0%	0.0%	0.0%	0.0%	0.0%	50.0%	50.0%	0.0%
Bicycles on Crosswalk	0	0	0	0	0	0	0	0	0	0	0	0	0	0	0	0	1	1	0
% Bicycles on Crosswalk	0.0%	0.0%	0.0%	0.0%	0.0%	0.0%	0.0%	0.0%	0.0%	0.0%	0.0%	0.0%	0.0%	0.0%	0.0%	0.0%	50.0%	50.0%	0.0%

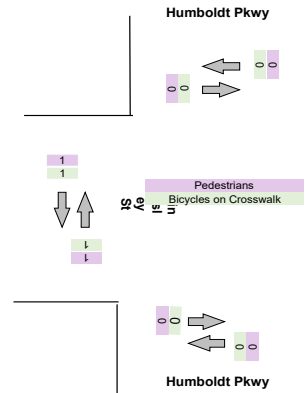
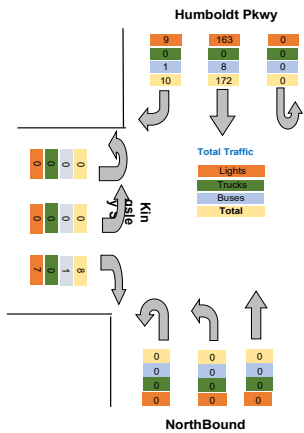

Turning Movement Data Plot

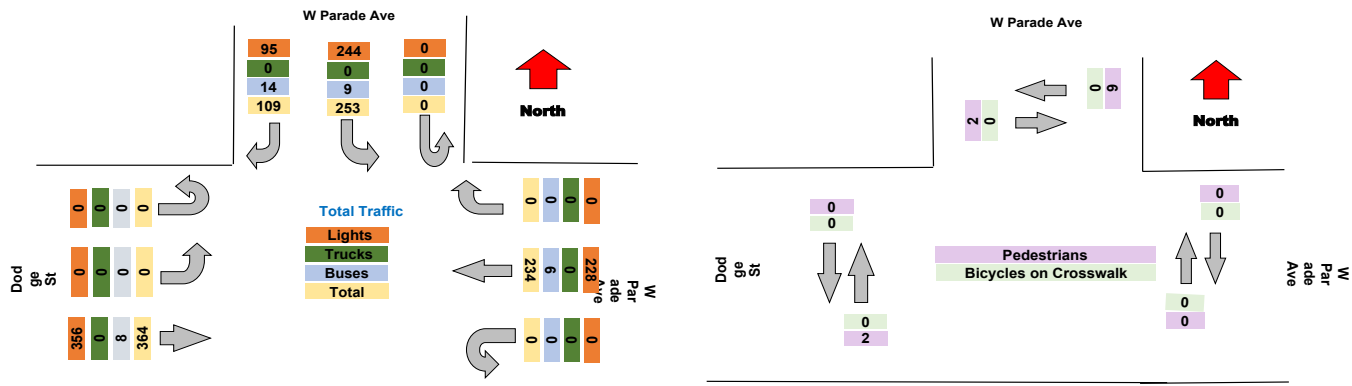

Turning Movement Peak Hour Data (AM)

7:30:00 AM

Leg Direction	W Parade Ave Southbound						W Parade Ave Westbound						Dodge St Eastbound						Total
	Right	Left	U-Turn	App Total	Peds CW	Peds CCW	Right	Thru	U-Turn	App Total	Peds CW	Peds CCW	Thru	Left	U-Turn	App Total	Peds CW	Peds CCW	
7:30:00 AM	6	9	0	15	0	0	0	11	0	11	0	0	21	0	0	21	0	0	47
7:45:00 AM	11	21	0	32	1	1	0	16	0	17	0	0	26	0	0	26	0	0	75
8:00:00 AM	8	17	0	25	0	0	0	18	0	18	0	0	27	0	0	27	0	0	70
8:15:00 AM	5	14	0	19	0	0	0	14	0	14	0	0	26	0	0	26	0	0	59
Grand Total	30	61	0	91	1	1	0	59	0	60	0	0	100	0	0	100	0	0	251
% Approach	33.0%	67.0%	0.0%	0.0%	0.0%	0.0%	0.0%	98.3%	0.0%	0.0%	0.0%	0.0%	100.0%	0.0%	0.0%	0.0%	0.0%	0.0%	
% Total	12.0%	24.3%	0.0%	36.3%	0.0%	0.0%	0.0%	23.5%	0.0%	23.9%	0.0%	0.0%	39.8%	0.0%	0.0%	39.8%	0.0%	0.0%	
PHF	0.682	0.726	0.000	0.711	0.000	0.000	0.000	0.819	0.000	0.833	0.000	0.000	0.926	0.000	0.000	0.926	0.000	0.000	0.837
Lights	23	60	0	83	0	0	0	56	0	56	0	0	97	0	0	97	0	0	236
% Lights	76.7%	98.4%	0.0%	91.2%	0.0%	0.0%	0.0%	94.9%	0.0%	93.3%	0.0%	0.0%	97.0%	0.0%	0.0%	97.0%	0.0%	0.0%	94.0%
Trucks	0	0	0	0	0	0	0	0	0	0	0	0	0	0	0	0	0	0	0
% Trucks	0.0%	0.0%	0.0%	0.0%	0.0%	0.0%	0.0%	0.0%	0.0%	0.0%	0.0%	0.0%	0.0%	0.0%	0.0%	0.0%	0.0%	0.0%	0.0%
Buses	7	1	0	8	0	0	0	3	0	3	0	0	3	0	0	3	0	0	14
% Buses	23.3%	1.6%	0.0%	0.0%	0.0%	0.0%	0.0%	5.1%	0.0%	0.0%	0.0%	0.0%	3.0%	0.0%	0.0%	0.0%	0.0%	0.0%	5.6%
Pedestrians	0	0	0	0	1	1	0	0	0	0	0	0	0	0	0	0	0	0	0
% Pedestrians	0.0%	0.0%	0.0%	0.0%	100.0%	100.0%	0.0%	0.0%	0.0%	0.0%	0.0%	0.0%	0.0%	0.0%	0.0%	0.0%	0.0%	0.0%	0.0%
Bicycles on Crosswalk	0	0	0	0	0	0	0	0	0	0	0	0	0	0	0	0	0	0	0
% Bicycles on Crosswalk	0.0%	0.0%	0.0%	0.0%	0.0%	0.0%	0.0%	0.0%	0.0%	0.0%	0.0%	0.0%	0.0%	0.0%	0.0%	0.0%	0.0%	0.0%	0.0%

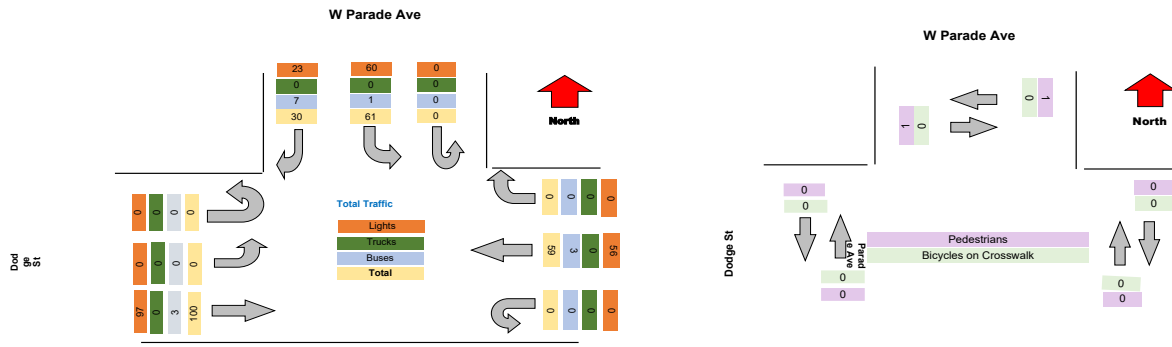

Turning Movement Peak Hour Data (PM)
 4:30:00 PM

Leg Direction	W Parade Ave Southbound						W Parade Ave Westbound						Dodge St Eastbound						Total
	Right	Left	U-Turn	App Total	Peds CW	Peds CCW	Right	Thru	U-Turn	App Total	Peds CW	Peds CCW	Thru	Left	U-Turn	App Total	Peds CW	Peds CCW	
4:30:00 PM	10	20	0	30	0	1	0	20	0	20	0	0	36	0	0	36	0	0	86
4:45:00 PM	12	15	0	27	0	1	0	22	0	22	0	0	24	0	0	24	1	0	73
5:00:00 PM	8	17	0	25	0	1	0	18	0	18	0	0	28	0	0	28	0	0	71
5:15:00 PM	6	22	0	28	0	0	0	18	0	18	0	0	21	0	0	21	0	0	67
Grand Total	36	74	0	110	0	3	0	78	0	78	0	0	109	0	0	109	1	0	297
% Approach	32.7%	67.3%	0.0%	0.0%	0.0%	0.0%	0.0%	100.0%	0.0%	0.0%	0.0%	0.0%	100.0%	0.0%	0.0%	0.0%	0.0%	0.0%	0.0%
% Total	12.1%	24.9%	0.0%	37.0%	0.0%	0.0%	0.0%	26.3%	0.0%	26.3%	0.0%	0.0%	36.7%	0.0%	0.0%	36.7%	0.0%	0.0%	0.0%
PHF	0.750	0.841	0.000	0.917	0.000	0.000	0.000	0.886	0.000	0.886	0.000	0.000	0.757	0.000	0.000	0.757	0.000	0.000	0.863
Lights	32	71	0	103	0	0	0	77	0	77	0	0	107	0	0	107	0	0	287
% Lights	88.9%	95.9%	0.0%	93.6%	0.0%	0.0%	0.0%	98.7%	0.0%	98.7%	0.0%	0.0%	98.2%	0.0%	0.0%	98.2%	0.0%	0.0%	96.6%
Trucks	0	0	0	0	0	0	0	0	0	0	0	0	0	0	0	0	0	0	0
% Trucks	0.0%	0.0%	0.0%	0.0%	0.0%	0.0%	0.0%	0.0%	0.0%	0.0%	0.0%	0.0%	0.0%	0.0%	0.0%	0.0%	0.0%	0.0%	0.0%
Buses	4	3	0	7	0	0	0	1	0	1	0	0	2	0	0	2	0	0	10
% Buses	11.1%	4.1%	0.0%	0.0%	0.0%	0.0%	0.0%	1.3%	0.0%	0.0%	0.0%	0.0%	1.8%	0.0%	0.0%	0.0%	0.0%	0.0%	3.4%
Pedestrians	0	0	0	0	0	3	0	0	0	0	0	0	0	0	0	0	1	0	0
% Pedestrians	0.0%	0.0%	0.0%	0.0%	0.0%	100.0%	0.0%	0.0%	0.0%	0.0%	0.0%	0.0%	0.0%	0.0%	0.0%	0.0%	100.0%	0.0%	0.0%
Bicycles on Crosswalk	0	0	0	0	0	0	0	0	0	0	0	0	0	0	0	0	0	0	0
% Bicycles on Crosswalk	0.0%	0.0%	0.0%	0.0%	0.0%	0.0%	0.0%	0.0%	0.0%	0.0%	0.0%	0.0%	0.0%	0.0%	0.0%	0.0%	0.0%	0.0%	0.0%

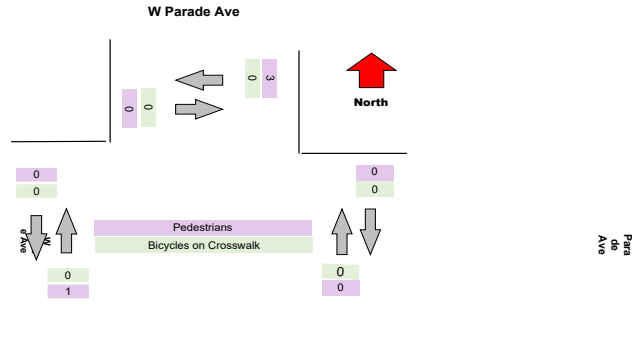
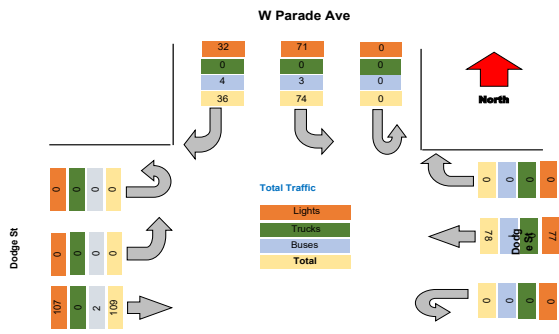

Para Ave

Intersection: Elm St Pine St
 Location: Kennett Square, PA
 Site: 01
 Survey Date: Wednesday, 04-28-2021
 GPS: 42.948550, -72.790034



Project	LaBella
Project Code	LaBella
Site Name	E
Legs and Movements	All Processed Legs & Movements
Bin Size	15 minutes
Survey Date	2021-10-27, Wednesday
Location	E
Latitude and Longitude	42.905537, -78.845300

	Start	End	PHF
Forced Peak AM	2021/10/27 07:30:00	2021/10/27 08:30:00	0.8409
Forced Peak PM	2021/10/27 16:30:00	2021/10/27 17:30:00	0.8639
AM Peak	2021/10/27 07:30:00	2021/10/27 08:30:00	0.8409
PM Peak	2021/10/27 16:30:00	2021/10/27 17:30:00	0.8639

Turning Movement Data

Leg Direction	W Parade Ave Southbound						W Parade Ave Westbound						Dodge St Eastbound						Total
	Right	Left	U-Turn	App Total	Peds CW	Peds CCW	Right	Thru	U-Turn	App Total	Peds CW	Peds CCW	Thru	Left	U-Turn	App Total	Peds CW	Peds CCW	
Start Time																			
6:30:00 AM	1	6	0	7	0	0	0	6	0	6	0	0	7	0	0	7	0	0	20
6:45:00 AM	5	8	0	13	0	0	0	6	0	6	0	1	8	0	0	9	0	0	28
Hourly Total	6	14	0	20	0	0	0	12	0	12	0	1	15	0	0	16	0	0	48
7:00:00 AM	0	9	0	9	1	0	0	4	0	4	0	0	11	0	0	11	0	0	24
7:15:00 AM	4	13	0	17	0	0	0	10	0	10	0	0	15	0	0	15	0	0	42
7:30:00 AM	2	6	0	8	2	0	1	15	0	16	0	0	15	0	0	15	0	0	39
7:45:00 AM	14	14	0	28	4	0	0	9	0	9	0	0	24	0	0	24	0	0	61
Hourly Total	20	42	0	62	7	0	1	38	0	39	0	0	65	0	0	65	0	0	166
8:00:00 AM	8	14	0	22	0	0	0	13	0	13	0	0	21	0	0	21	0	0	56
8:15:00 AM	4	13	0	17	0	1	0	20	0	21	0	0	28	0	0	28	0	0	66
Hourly Total	12	27	0	39	0	1	0	33	0	34	0	0	49	0	0	49	0	0	122
4:00:00 PM	13	23	0	36	0	1	0	26	0	26	0	0	63	0	0	63	0	0	125
4:15:00 PM	10	21	0	31	0	2	0	18	0	18	0	0	35	0	0	35	0	0	84
4:30:00 PM	10	26	0	36	0	0	0	17	0	17	0	0	37	0	0	37	0	0	90
4:45:00 PM	13	27	0	40	2	1	0	24	0	24	0	0	37	0	0	37	0	0	101
Hourly Total	46	97	0	143	2	4	0	85	0	85	0	0	172	0	0	172	0	0	400
5:00:00 PM	6	15	0	21	0	1	0	18	0	18	0	0	31	0	0	31	0	0	70
5:15:00 PM	11	18	0	29	1	0	0	21	0	21	0	0	38	0	0	38	0	0	88
5:30:00 PM	9	19	0	28	0	1	0	23	0	23	0	0	24	0	0	24	0	0	75
5:45:00 PM	11	10	0	21	0	0	0	20	0	20	0	0	21	0	0	21	0	0	62
Hourly Total	37	62	0	99	1	2	0	82	0	82	0	0	114	0	0	114	0	0	295
Grand Total	121	242	0	363	10	7	1	250	0	252	0	1	415	0	0	416	0	0	1031
% Approach	33.3%	66.7%	0.0%	0.0%	0.0%	0.0%	0.4%	99.2%	0.0%	0.0%	0.0%	0.0%	99.8%	0.0%	0.0%	0.0%	0.0%	0.0%	0.0%
% Total	11.7%	23.5%	0.0%	35.2%	0.0%	0.0%	0.1%	24.2%	0.0%	24.4%	0.0%	0.0%	40.3%	0.0%	0.0%	40.3%	0.0%	0.0%	0.0%
Lights	104	232	0	336	0	0	1	242	0	243	0	0	403	0	0	403	0	0	982
% Lights	86.0%	95.9%	0.0%	92.6%	0.0%	0.0%	100.0%	96.8%	0.0%	96.4%	0.0%	0.0%	97.1%	0.0%	0.0%	96.9%	0.0%	0.0%	95.2%
Trucks	0	0	0	0	0	0	0	1	0	1	0	0	0	0	0	0	0	0	1
% Trucks	0.0%	0.0%	0.0%	0.0%	0.0%	0.0%	0.0%	0.4%	0.0%	0.4%	0.0%	0.0%	0.0%	0.0%	0.0%	0.0%	0.0%	0.0%	0.1%
Buses	17	9	0	26	0	0	0	7	0	7	0	0	11	0	0	11	0	0	44
% Buses	14.0%	3.7%	0.0%	0.0%	0.0%	0.0%	0.0%	2.8%	0.0%	0.0%	0.0%	0.0%	2.7%	0.0%	0.0%	0.0%	0.0%	0.0%	4.3%
Pedestrians	0	0	0	0	10	6	0	0	0	0	0	1	0	0	0	0	0	0	0
% Pedestrians	0.0%	0.0%	0.0%	0.0%	100.0%	85.7%	0.0%	0.0%	0.0%	0.0%	0.0%	100.0%	0.0%	0.0%	0.0%	0.0%	0.0%	0.0%	0.0%
Bicycles on Crosswalk	0	0	0	0	0	1	0	0	0	0	0	0	0	0	0	0	0	0	0
% Bicycles on Crosswalk	0.0%	0.0%	0.0%	0.0%	0.0%	14.3%	0.0%	0.0%	0.0%	0.0%	0.0%	0.0%	0.0%	0.0%	0.0%	0.0%	0.0%	0.0%	0.0%

Turning Movement Data Plot

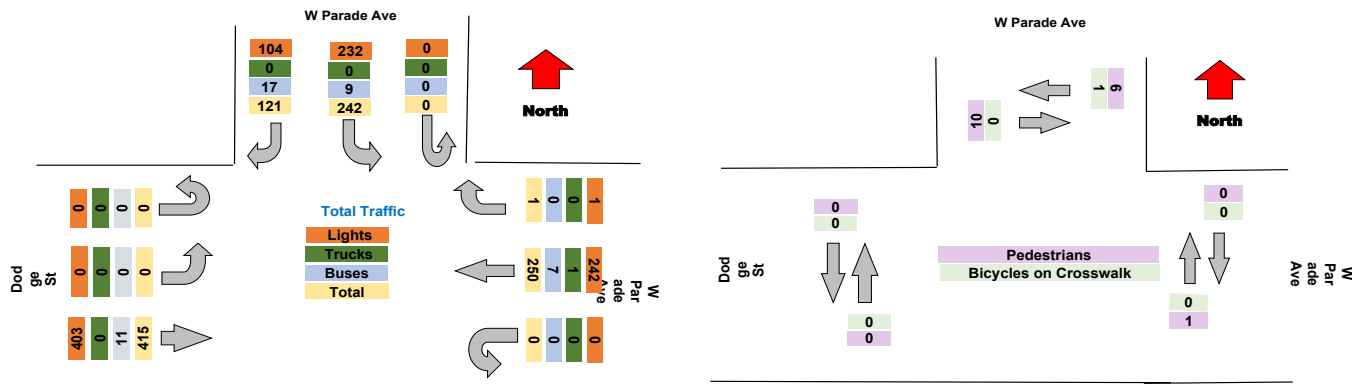

Turning Movement Peak Hour Data (AM)

7:30:00 AM

Leg Direction	W Parade Ave Southbound						W Parade Ave Westbound						Dodge St Eastbound						Total
	Right	Left	U-Turn	App Total	Peds CW	Peds CCW	Right	Thru	U-Turn	App Total	Peds CW	Peds CCW	Thru	Left	U-Turn	App Total	Peds CW	Peds CCW	
7:30:00 AM	2	6	0	8	2	0	1	15	0	16	0	0	15	0	0	15	0	0	39
7:45:00 AM	14	14	0	28	4	0	0	9	0	9	0	0	24	0	0	24	0	0	61
8:00:00 AM	8	14	0	22	0	0	0	13	0	13	0	0	21	0	0	21	0	0	56
8:15:00 AM	4	13	0	17	0	1	0	20	0	21	0	0	28	0	0	28	0	0	66
Grand Total	28	47	0	75	6	1	1	57	0	59	0	0	88	0	0	88	0	0	222
% Approach	37.3%	62.7%	0.0%	0.0%	0.0%	0.0%	1.7%	96.6%	0.0%	0.0%	0.0%	0.0%	100.0%	0.0%	0.0%	0.0%	0.0%	0.0%	
% Total	12.6%	21.2%	0.0%	33.8%	0.0%	0.0%	0.5%	25.7%	0.0%	26.6%	0.0%	0.0%	39.6%	0.0%	0.0%	39.6%	0.0%	0.0%	
PHF	0.500	0.839	0.000	0.670	0.000	0.000	0.250	0.713	0.000	0.702	0.000	0.000	0.786	0.000	0.000	0.786	0.000	0.000	0.841
Lights	22	46	0	68	0	0	1	55	0	56	0	0	85	0	0	85	0	0	209
% Lights	78.6%	97.9%	0.0%	90.7%	0.0%	0.0%	100.0%	96.5%	0.0%	94.9%	0.0%	0.0%	96.6%	0.0%	0.0%	96.6%	0.0%	0.0%	94.1%
Trucks	0	0	0	0	0	0	0	0	0	0	0	0	0	0	0	0	0	0	0
% Trucks	0.0%	0.0%	0.0%	0.0%	0.0%	0.0%	0.0%	0.0%	0.0%	0.0%	0.0%	0.0%	0.0%	0.0%	0.0%	0.0%	0.0%	0.0%	0.0%
Buses	6	1	0	7	0	0	0	2	0	2	0	0	3	0	0	3	0	0	12
% Buses	21.4%	2.1%	0.0%	0.0%	0.0%	0.0%	0.0%	3.5%	0.0%	0.0%	0.0%	0.0%	3.4%	0.0%	0.0%	0.0%	0.0%	0.0%	5.4%
Pedestrians	0	0	0	0	6	1	0	0	0	0	0	0	0	0	0	0	0	0	0
% Pedestrians	0.0%	0.0%	0.0%	0.0%	100.0%	100.0%	0.0%	0.0%	0.0%	0.0%	0.0%	0.0%	0.0%	0.0%	0.0%	0.0%	0.0%	0.0%	0.0%
Bicycles on Crosswalk	0	0	0	0	0	0	0	0	0	0	0	0	0	0	0	0	0	0	0
% Bicycles on Crosswalk	0.0%	0.0%	0.0%	0.0%	0.0%	0.0%	0.0%	0.0%	0.0%	0.0%	0.0%	0.0%	0.0%	0.0%	0.0%	0.0%	0.0%	0.0%	0.0%

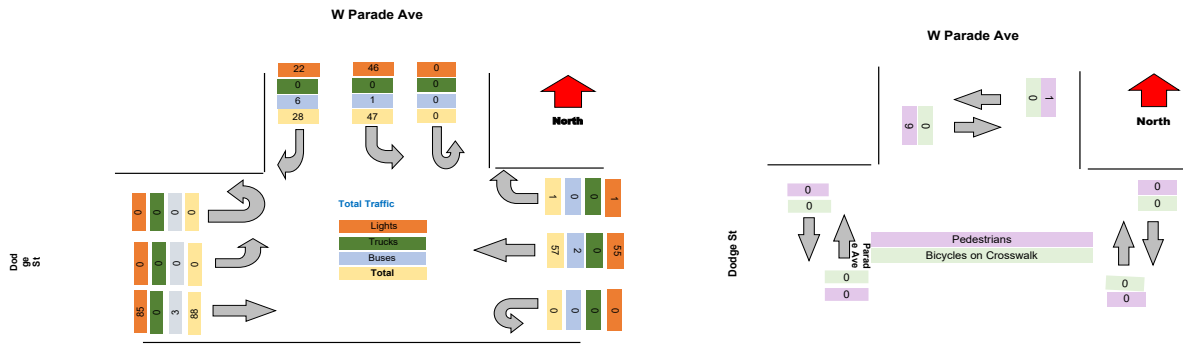

Turning Movement Peak Hour Data (PM)
 4:30:00 PM

Leg Direction	W Parade Ave Southbound						W Parade Ave Westbound						Dodge St Eastbound						Total
	Right	Left	U-Turn	App Total	Peds CW	Peds CCW	Right	Thru	U-Turn	App Total	Peds CW	Peds CCW	Thru	Left	U-Turn	App Total	Peds CW	Peds CCW	
4:30:00 PM	10	26	0	36	0	0	0	17	0	17	0	0	37	0	0	37	0	0	90
4:45:00 PM	13	27	0	40	2	1	0	24	0	24	0	0	37	0	0	37	0	0	101
5:00:00 PM	6	15	0	21	0	1	0	18	0	18	0	0	31	0	0	31	0	0	70
5:15:00 PM	11	18	0	29	1	0	0	21	0	21	0	0	38	0	0	38	0	0	88
Grand Total	40	86	0	126	3	2	0	80	0	80	0	0	143	0	0	143	0	0	349
% Approach	31.7%	68.3%	0.0%	0.0%	0.0%	0.0%	0.0%	100.0%	0.0%	0.0%	0.0%	0.0%	100.0%	0.0%	0.0%	0.0%	0.0%	0.0%	0.0%
% Total	11.5%	24.6%	0.0%	36.1%	0.0%	0.0%	0.0%	22.9%	0.0%	22.9%	0.0%	0.0%	41.0%	0.0%	0.0%	41.0%	0.0%	0.0%	0.0%
PHF	0.769	0.796	0.000	0.788	0.000	0.000	0.000	0.833	0.000	0.833	0.000	0.000	0.941	0.000	0.000	0.941	0.000	0.000	0.864
Lights	33	84	0	117	0	0	0	78	0	78	0	0	139	0	0	139	0	0	334
% Lights	82.5%	97.7%	0.0%	92.9%	0.0%	0.0%	0.0%	97.5%	0.0%	97.5%	0.0%	0.0%	97.2%	0.0%	0.0%	97.2%	0.0%	0.0%	95.7%
Trucks	0	0	0	0	0	0	0	0	0	0	0	0	0	0	0	0	0	0	0
% Trucks	0.0%	0.0%	0.0%	0.0%	0.0%	0.0%	0.0%	0.0%	0.0%	0.0%	0.0%	0.0%	0.0%	0.0%	0.0%	0.0%	0.0%	0.0%	0.0%
Buses	7	1	0	8	0	0	0	2	0	2	0	0	3	0	0	3	0	0	13
% Buses	17.5%	1.2%	0.0%	0.0%	0.0%	0.0%	0.0%	2.5%	0.0%	0.0%	0.0%	0.0%	2.1%	0.0%	0.0%	0.0%	0.0%	0.0%	3.7%
Pedestrians	0	0	0	0	3	1	0	0	0	0	0	0	0	0	0	0	0	0	0
% Pedestrians	0.0%	0.0%	0.0%	0.0%	100.0%	50.0%	0.0%	0.0%	0.0%	0.0%	0.0%	0.0%	0.0%	0.0%	0.0%	0.0%	0.0%	0.0%	0.0%
Bicycles on Crosswalk	0	0	0	0	0	1	0	0	0	0	0	0	0	0	0	0	0	0	0
% Bicycles on Crosswalk	0.0%	0.0%	0.0%	0.0%	0.0%	50.0%	0.0%	0.0%	0.0%	0.0%	0.0%	0.0%	0.0%	0.0%	0.0%	0.0%	0.0%	0.0%	0.0%

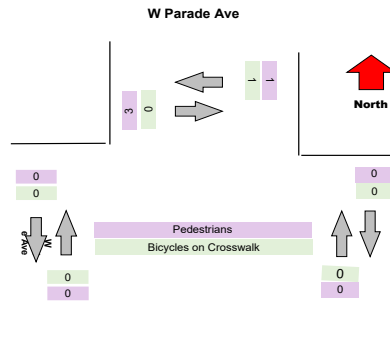
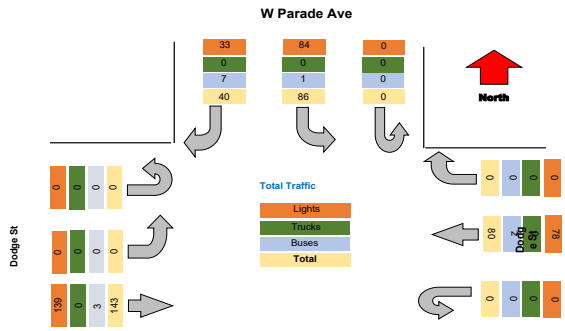

Para
de
Ave

Intersection: Elm St Pine St
 Location: Kennett Square, PA
 Site: 01
 Survey Date: Wednesday, 04-28-2021
 GPS: 42.948550, -72.790034



Project	LaBella
Project Code	LaBella
Site Name	E
Legs and Movements	All Processed Legs & Movements
Bin Size	15 minutes
Survey Date	2021-10-28, Thursday
Location	E
Latitude and Longitude	42.905537, -78.845300

	Start	End	PHF
Forced Peak AM	2021/10/28 07:30:00	2021/10/28 08:30:00	0.7992
Forced Peak PM	2021/10/28 16:30:00	2021/10/28 17:30:00	0.8801
AM Peak	2021/10/28 07:30:00	2021/10/28 08:30:00	0.7992
PM Peak	2021/10/28 16:30:00	2021/10/28 17:30:00	0.8801

Turning Movement Data

Leg Direction	W Parade Ave Southbound					W Parade Ave Westbound					Dodge St Eastbound					Total
	Right	Left	U-Turn	App Total	Peds CW Peds CCW	Right	Thru	U-Turn	App Total	Peds CW Peds CCW	Thru	Left	U-Turn	App Total	Peds CW Peds CCW	
Start Time																
6:30:00 AM	3	6	0	9	0 0	0	2	0	2	0 0	8	0	0	8	0 0	19
6:45:00 AM	5	5	0	10	0 0	0	2	0	2	0 1	6	0	0	7	0 0	19
Hourly Total	8	11	0	19	0 0	0	4	0	4	0 1	14	0	0	15	0 0	38
7:00:00 AM	2	9	0	11	0 0	0	8	0	8	0 0	16	0	0	16	0 0	35
7:15:00 AM	4	7	0	11	1 0	0	11	0	11	0 0	12	0	0	12	0 0	34
7:30:00 AM	7	5	0	12	1 0	0	7	0	7	0 0	13	0	0	13	0 0	32
7:45:00 AM	8	13	0	21	4 0	0	13	0	13	1 0	26	0	0	27	0 0	61
Hourly Total	21	34	0	55	6 0	0	39	0	39	1 0	67	0	0	68	0 0	162
8:00:00 AM	7	15	0	22	0 0	0	17	0	17	0 0	20	0	0	20	0 0	59
8:15:00 AM	0	15	0	15	0 1	0	12	0	13	0 0	15	0	0	15	0 0	43
Hourly Total	7	30	0	37	0 1	0	29	0	30	0 0	35	0	0	35	0 0	102
4:00:00 PM	10	24	0	34	0 1	0	21	0	21	0 0	49	0	0	49	0 0	104
4:15:00 PM	8	21	0	29	4 0	0	18	0	18	0 0	50	0	0	50	0 0	97
4:30:00 PM	15	23	0	38	2 2	0	25	0	25	0 0	35	0	0	35	0 1	98
4:45:00 PM	8	16	0	24	2 0	0	28	0	28	0 0	32	0	0	32	0 1	84
Hourly Total	41	84	0	125	8 3	0	92	0	92	0 0	166	0	0	166	0 2	383
5:00:00 PM	5	19	0	24	0 0	0	22	0	22	0 0	31	0	0	31	0 0	77
5:15:00 PM	10	20	0	30	0 0	0	22	0	22	0 0	34	0	0	34	0 0	86
5:30:00 PM	8	17	0	25	1 1	0	28	0	28	0 0	23	0	0	23	0 0	76
5:45:00 PM	11	17	0	28	0 0	0	21	0	21	0 0	23	0	0	23	0 0	72
Hourly Total	34	73	0	107	1 1	0	93	0	93	0 0	111	0	0	111	0 0	311
Grand Total	111	232	0	343	15 5	0	257	0	258	1 1	393	0	0	395	0 2	996
% Approach	32.4%	67.6%	0.0%	0.0%	0.0% 0.0%	0.0%	99.6%	0.0%	0.0%	0.0% 0.0%	99.5%	0.0%	0.0%	0.0%	0.0% 0.0%	0.0%
% Total	11.1%	23.3%	0.0%	34.4%	0.0% 0.0%	0.0%	25.8%	0.0%	25.9%	0.0% 0.0%	39.5%	0.0%	0.0%	39.7%	0.0% 0.0%	0.0%
Lights	96	220	0	316	0 0	0	248	0	248	0 0	384	0	0	384	0 0	948
% Lights	86.5%	94.8%	0.0%	92.1%	0.0% 0.0%	0.0%	96.5%	0.0%	96.1%	0.0% 0.0%	97.7%	0.0%	0.0%	97.2%	0.0% 0.0%	95.2%
Trucks	0	0	0	0	0 0	0	0	0	0	0 0	0	0	0	0	0 0	0
% Trucks	0.0%	0.0%	0.0%	0.0%	0.0% 0.0%	0.0%	0.0%	0.0%	0.0%	0.0% 0.0%	0.0%	0.0%	0.0%	0.0%	0.0% 0.0%	0.0%
Buses	15	11	0	26	0 0	0	9	0	9	0 0	9	0	0	9	0 0	44
% Buses	13.5%	4.7%	0.0%	0.0%	0.0% 0.0%	0.0%	3.5%	0.0%	0.0%	0.0% 0.0%	2.3%	0.0%	0.0%	0.0%	0.0% 0.0%	4.4%
Pedestrians	0	0	0	0	15 5	0	0	0	0	1 1	0	0	0	0	0 1	0
% Pedestrians	0.0%	0.0%	0.0%	0.0%	100.0% 100.0%	0.0%	0.0%	0.0%	0.0%	100.0% 100.0%	0.0%	0.0%	0.0%	0.0%	0.0% 50.0%	0.0%
Bicycles on Crosswalk	0	0	0	0	0 0	0	0	0	0	0 0	0	0	0	0	0 1	0
% Bicycles on Crosswalk	0.0%	0.0%	0.0%	0.0%	0.0% 0.0%	0.0%	0.0%	0.0%	0.0%	0.0% 0.0%	0.0%	0.0%	0.0%	0.0%	0.0% 50.0%	0.0%

Turning Movement Data Plot

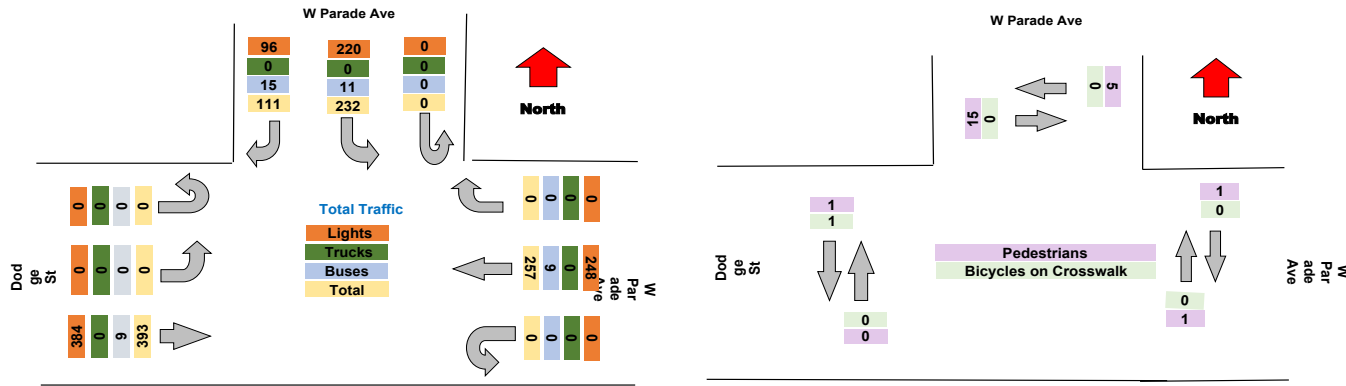

Turning Movement Peak Hour Data (AM)

7:30:00 AM

Leg Direction	W Parade Ave Southbound						W Parade Ave Westbound						Dodge St Eastbound						Total
	Right	Left	U-Turn	App Total	Peds CW	Peds CCW	Right	Thru	U-Turn	App Total	Peds CW	Peds CCW	Thru	Left	U-Turn	App Total	Peds CW	Peds CCW	
7:30:00 AM	7	5	0	12	1	0	0	7	0	7	0	0	13	0	0	13	0	0	32
7:45:00 AM	8	13	0	21	4	0	0	13	0	13	1	0	26	0	0	27	0	0	61
8:00:00 AM	7	15	0	22	0	0	0	17	0	17	0	0	20	0	0	20	0	0	59
8:15:00 AM	0	15	0	15	0	1	0	12	0	13	0	0	15	0	0	15	0	0	43
Grand Total	22	48	0	70	5	1	0	49	0	50	1	0	74	0	0	75	0	0	195
% Approach	31.4%	68.6%	0.0%	0.0%	0.0%	0.0%	0.0%	98.0%	0.0%	0.0%	0.0%	0.0%	98.7%	0.0%	0.0%	0.0%	0.0%	0.0%	
% Total	11.3%	24.6%	0.0%	35.9%	0.0%	0.0%	0.0%	25.1%	0.0%	25.6%	0.0%	0.0%	37.9%	0.0%	0.0%	38.5%	0.0%	0.0%	
PHF	0.688	0.800	0.000	0.795	0.000	0.000	0.000	0.721	0.000	0.735	0.000	0.000	0.712	0.000	0.000	0.694	0.000	0.000	0.799
Lights	15	47	0	62	0	0	0	46	0	46	0	0	72	0	0	72	0	0	180
% Lights	68.2%	97.9%	0.0%	88.6%	0.0%	0.0%	0.0%	93.9%	0.0%	92.0%	0.0%	0.0%	97.3%	0.0%	0.0%	96.0%	0.0%	0.0%	92.3%
Trucks	0	0	0	0	0	0	0	0	0	0	0	0	0	0	0	0	0	0	0
% Trucks	0.0%	0.0%	0.0%	0.0%	0.0%	0.0%	0.0%	0.0%	0.0%	0.0%	0.0%	0.0%	0.0%	0.0%	0.0%	0.0%	0.0%	0.0%	0.0%
Buses	7	1	0	8	0	0	0	3	0	3	0	0	2	0	0	2	0	0	13
% Buses	31.8%	2.1%	0.0%	0.0%	0.0%	0.0%	0.0%	6.1%	0.0%	0.0%	0.0%	0.0%	2.7%	0.0%	0.0%	0.0%	0.0%	0.0%	6.7%
Pedestrians	0	0	0	0	5	1	0	0	0	0	1	0	0	0	0	0	0	0	0
% Pedestrians	0.0%	0.0%	0.0%	0.0%	100.0%	100.0%	0.0%	0.0%	0.0%	0.0%	100.0%	0.0%	0.0%	0.0%	0.0%	0.0%	0.0%	0.0%	0.0%
Bicycles on Crosswalk	0	0	0	0	0	0	0	0	0	0	0	0	0	0	0	0	0	0	0
% Bicycles on Crosswalk	0.0%	0.0%	0.0%	0.0%	0.0%	0.0%	0.0%	0.0%	0.0%	0.0%	0.0%	0.0%	0.0%	0.0%	0.0%	0.0%	0.0%	0.0%	0.0%

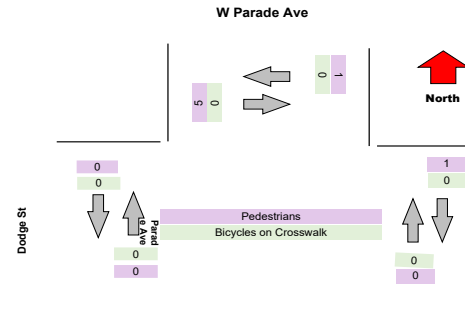
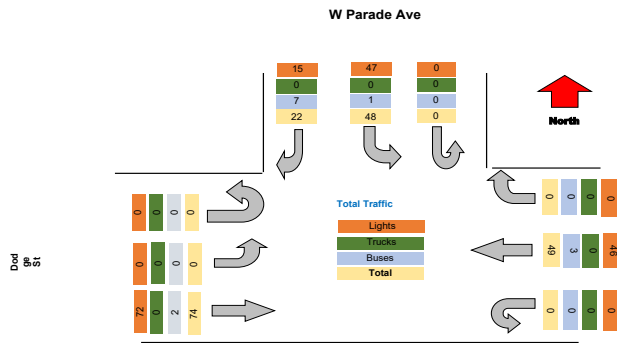

Turning Movement Peak Hour Data (PM)
 4:30:00 PM

Leg Direction	W Parade Ave Southbound						W Parade Ave Westbound						Dodge St Eastbound						Total
	Right	Left	U-Turn	App Total	Peds CW	Peds CCW	Right	Thru	U-Turn	App Total	Peds CW	Peds CCW	Thru	Left	U-Turn	App Total	Peds CW	Peds CCW	
4:30:00 PM	15	23	0	38	2	2	0	25	0	25	0	0	35	0	0	35	0	1	98
4:45:00 PM	8	16	0	24	2	0	0	28	0	28	0	0	32	0	0	32	0	1	84
5:00:00 PM	5	19	0	24	0	0	0	22	0	22	0	0	31	0	0	31	0	0	77
5:15:00 PM	10	20	0	30	0	0	0	22	0	22	0	0	34	0	0	34	0	0	86
Grand Total	38	78	0	116	4	2	0	97	0	97	0	0	132	0	0	132	0	2	345
% Approach	32.8%	67.2%	0.0%	0.0%	0.0%	0.0%	0.0%	100.0%	0.0%	0.0%	0.0%	0.0%	100.0%	0.0%	0.0%	0.0%	0.0%	0.0%	0.0%
% Total	11.0%	22.6%	0.0%	33.6%	0.0%	0.0%	0.0%	28.1%	0.0%	28.1%	0.0%	0.0%	38.3%	0.0%	0.0%	38.3%	0.0%	0.0%	0.0%
PHF	0.633	0.848	0.000	0.763	0.000	0.000	0.000	0.866	0.000	0.866	0.000	0.000	0.943	0.000	0.000	0.943	0.000	0.000	0.000
Lights	32	76	0	108	0	0	0	93	0	93	0	0	130	0	0	130	0	0	331
% Lights	84.2%	97.4%	0.0%	93.1%	0.0%	0.0%	0.0%	95.9%	0.0%	95.9%	0.0%	0.0%	98.5%	0.0%	0.0%	98.5%	0.0%	0.0%	95.9%
Trucks	0	0	0	0	0	0	0	0	0	0	0	0	0	0	0	0	0	0	0
% Trucks	0.0%	0.0%	0.0%	0.0%	0.0%	0.0%	0.0%	0.0%	0.0%	0.0%	0.0%	0.0%	0.0%	0.0%	0.0%	0.0%	0.0%	0.0%	0.0%
Buses	6	1	0	7	0	0	0	4	0	4	0	0	2	0	0	2	0	0	13
% Buses	15.8%	1.3%	0.0%	0.0%	0.0%	0.0%	0.0%	4.1%	0.0%	0.0%	0.0%	0.0%	1.5%	0.0%	0.0%	0.0%	0.0%	0.0%	3.8%
Pedestrians	0	0	0	0	4	2	0	0	0	0	0	0	0	0	0	0	0	1	0
% Pedestrians	0.0%	0.0%	0.0%	0.0%	100.0%	100.0%	0.0%	0.0%	0.0%	0.0%	0.0%	0.0%	0.0%	0.0%	0.0%	0.0%	0.0%	50.0%	0.0%
Bicycles on Crosswalk	0	0	0	0	0	0	0	0	0	0	0	0	0	0	0	0	0	1	0
% Bicycles on Crosswalk	0.0%	0.0%	0.0%	0.0%	0.0%	0.0%	0.0%	0.0%	0.0%	0.0%	0.0%	0.0%	0.0%	0.0%	0.0%	0.0%	0.0%	50.0%	0.0%

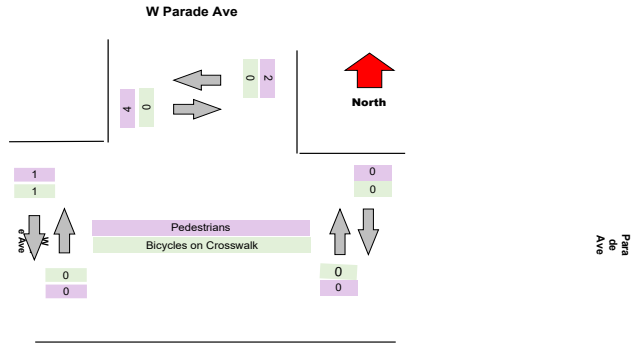
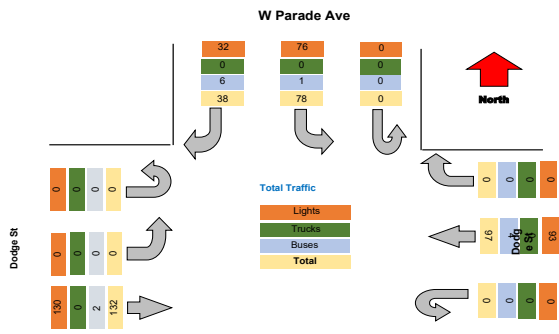

Turning Movement Data Plot

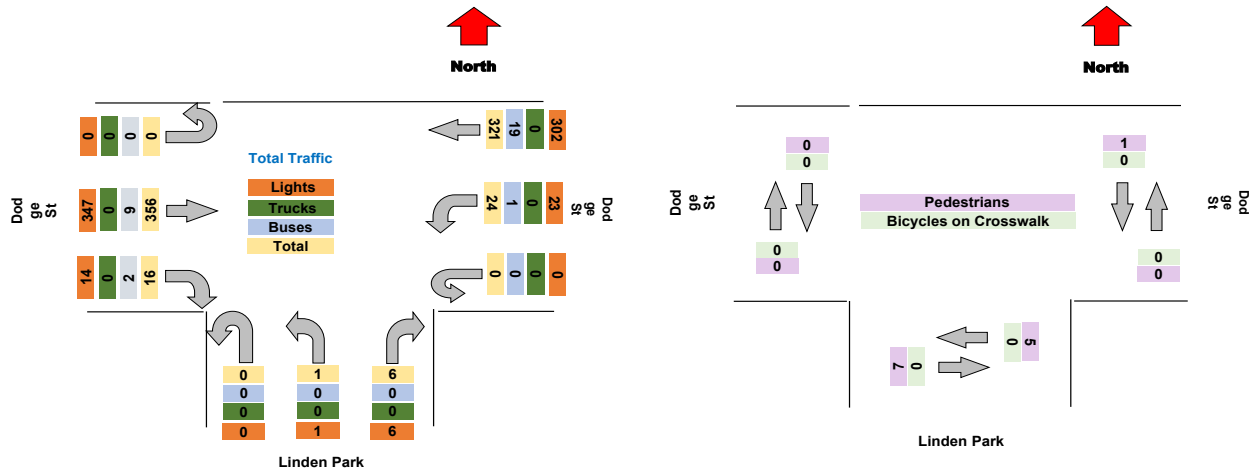

Turning Movement Peak Hour Data (AM)
7:30:00 AM

Leg Direction	Dodge St Westbound						Linden Park Northbound						Dodge St Eastbound						Total
	Thru	Left	U-Turn	App Total	Peds CW	Peds CCW	Right	Left	U-Turn	App Total	Peds CW	Peds CCW	Right	Thru	U-Turn	App Total	Peds CW	Peds CCW	
7:30:00 AM	19	1	0	20	0	0	0	0	0	0	0	1	0	22	0	23	0	0	43
7:45:00 AM	25	1	0	26	0	0	0	0	0	0	1	1	0	25	0	27	0	0	53
8:00:00 AM	26	1	0	27	0	0	2	0	2	1	0	0	1	25	0	27	0	0	56
8:15:00 AM	17	2	0	19	0	0	1	0	1	0	0	0	1	25	0	26	0	0	46
Grand Total	87	5	0	92	0	0	3	0	3	2	2	2	2	97	0	103	0	0	198
% Approach	94.6%	5.4%	0.0%	0.0%	0.0%	0.0%	14.2%	0.0%	0.0%	0.0%	0.0%	0.0%	45.1%	41.7%	0.0%	0.0%	0.0%	0.0%	
% Total	43.9%	2.5%	0.0%	46.5%	0.0%	0.0%	1.5%	0.0%	0.0%	1.5%	0.0%	0.0%	1.0%	49.0%	0.0%	52.0%	0.0%	0.0%	
PHF	0.837	0.625	0.000	0.852	0.000	0.000	0.375	0.000	0.000	0.375	0.000	0.000	0.500	0.970	0.000	0.954	0.000	0.000	0.884
Lights	77	5	0	82	0	0	3	0	3	0	0	3	2	94	0	96	0	0	181
% Lights	88.5%	100.0%	0.0%	89.1%	0.0%	0.0%	100.0%	0.0%	0.0%	100.0%	0.0%	0.0%	100.0%	96.9%	0.0%	93.2%	0.0%	0.0%	91.4%
Trucks	0	0	0	0	0	0	0	0	0	0	0	0	0	0	0	0	0	0	0
% Trucks	0.0%	0.0%	0.0%	0.0%	0.0%	0.0%	0.0%	0.0%	0.0%	0.0%	0.0%	0.0%	0.0%	0.0%	0.0%	0.0%	0.0%	0.0%	0.0%
Buses	10	0	0	10	0	0	0	0	0	0	0	0	0	3	0	3	0	0	13
% Buses	11.5%	0.0%	0.0%	0.0%	0.0%	0.0%	0.0%	0.0%	0.0%	0.0%	0.0%	0.0%	0.0%	3.1%	0.0%	0.0%	0.0%	0.0%	6.6%
Pedestrians	0	0	0	0	0	0	0	0	0	2	2	0	0	0	0	0	0	0	0
% Pedestrians	0.0%	0.0%	0.0%	0.0%	0.0%	0.0%	0.0%	0.0%	0.0%	0.0%	100.0%	100.0%	0.0%	0.0%	0.0%	0.0%	0.0%	0.0%	0.0%
Bicycles on Crosswalk	0	0	0	0	0	0	0	0	0	0	0	0	0	0	0	0	0	0	0
% Bicycles on Crosswalk	0.0%	0.0%	0.0%	0.0%	0.0%	0.0%	0.0%	0.0%	0.0%	0.0%	0.0%	0.0%	0.0%	0.0%	0.0%	0.0%	0.0%	0.0%	0.0%

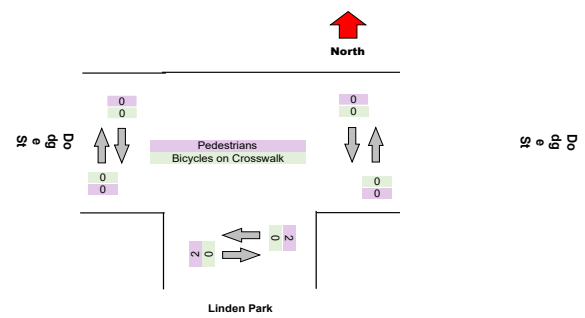
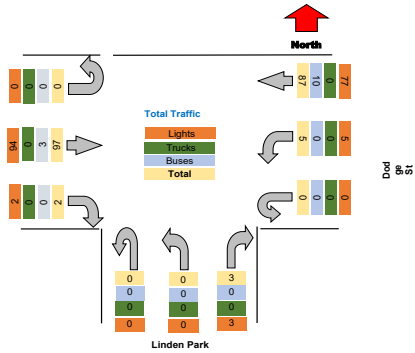

Turning Movement Peak Hour Data (PM)
4:30:00 PM

Leg Direction	Dodge St Westbound						Linden Park Northbound						Dodge St Eastbound						Total
	Thru	Left	U-Turn	App Total	Peds CW	Peds CCW	Right	Left	U-Turn	App Total	Peds CW	Peds CCW	Right	Thru	U-Turn	App Total	Peds CW	Peds CCW	
4:30:00 PM	29	1	0	30	0	0	0	0	0	0	1	0	4	36	0	40	0	0	70
4:45:00 PM	29	4	0	33	0	0	0	0	0	0	1	0	2	24	0	26	0	0	59
5:00:00 PM	24	2	0	26	0	0	2	1	0	3	0	0	2	26	0	28	0	0	57
5:15:00 PM	25	0	0	25	0	0	1	0	0	1	0	0	0	19	0	19	0	0	45
Grand Total	107	7	0	114	0	0	3	1	0	4	0	2	8	105	0	113	0	0	231
% Approach	93.9%	6.1%	0.0%	0.0%	0.0%	0.0%	14.2%	0.0%	0.0%	0.0%	0.0%	0.0%	45.1%	41.7%	0.0%	0.0%	0.0%	0.0%	
% Total	46.3%	3.0%	0.0%	49.4%	0.0%	0.0%	1.3%	0.4%	0.0%	1.7%	0.0%	0.0%	3.5%	45.5%	0.0%	48.9%	0.0%	0.0%	
PHF	0.922	0.438	0.000	0.864	0.000	0.000	0.375	0.250	0.000	0.333	0.000	0.000	0.500	0.729	0.000	0.706	0.000	0.000	0.825
Lights	103	6	0	109	0	0	3	1	0	4	0	0	6	103	0	109	0	0	222
% Lights	96.3%	85.7%	0.0%	95.6%	0.0%	0.0%	100.0%	100.0%	0.0%	100.0%	0.0%	0.0%	75.0%	98.1%	0.0%	96.5%	0.0%	0.0%	96.1%
Trucks	0	0	0	0	0	0	0	0	0	0	0	0	0	0	0	0	0	0	0
% Trucks	0.0%	0.0%	0.0%	0.0%	0.0%	0.0%	0.0%	0.0%	0.0%	0.0%	0.0%	0.0%	0.0%	0.0%	0.0%	0.0%	0.0%	0.0%	0.0%
Buses	4	1	0	5	0	0	0	0	0	0	0	0	2	2	0	4	0	0	9
% Buses	3.7%	14.3%	0.0%	0.0%	0.0%	0.0%	0.0%	0.0%	0.0%	0.0%	0.0%	0.0%	25.0%	1.9%	0.0%	0.0%	0.0%	0.0%	3.9%
Pedestrians	0	0	0	0	0	0	0	0	0	0	2	0	0	0	0	0	0	0	0
% Pedestrians	0.0%	0.0%	0.0%	0.0%	0.0%	0.0%	0.0%	0.0%	0.0%	0.0%	100.0%	0.0%	0.0%	0.0%	0.0%	0.0%	0.0%	0.0%	0.0%
Bicycles on Crosswalk	0	0	0	0	0	0	0	0	0	0	0	0	0	0	0	0	0	0	0
% Bicycles on Crosswalk	0.0%	0.0%	0.0%	0.0%	0.0%	0.0%	0.0%	0.0%	0.0%	0.0%	0.0%	0.0%	0.0%	0.0%	0.0%	0.0%	0.0%	0.0%	0.0%

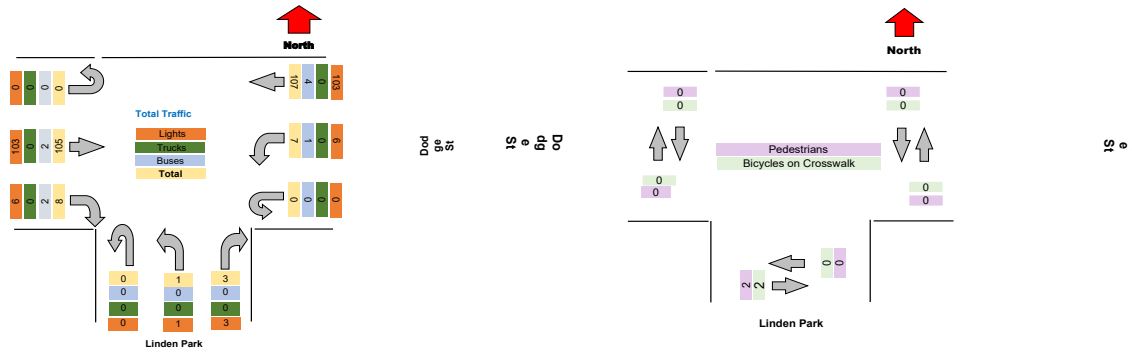

Turning Movement Data Plot

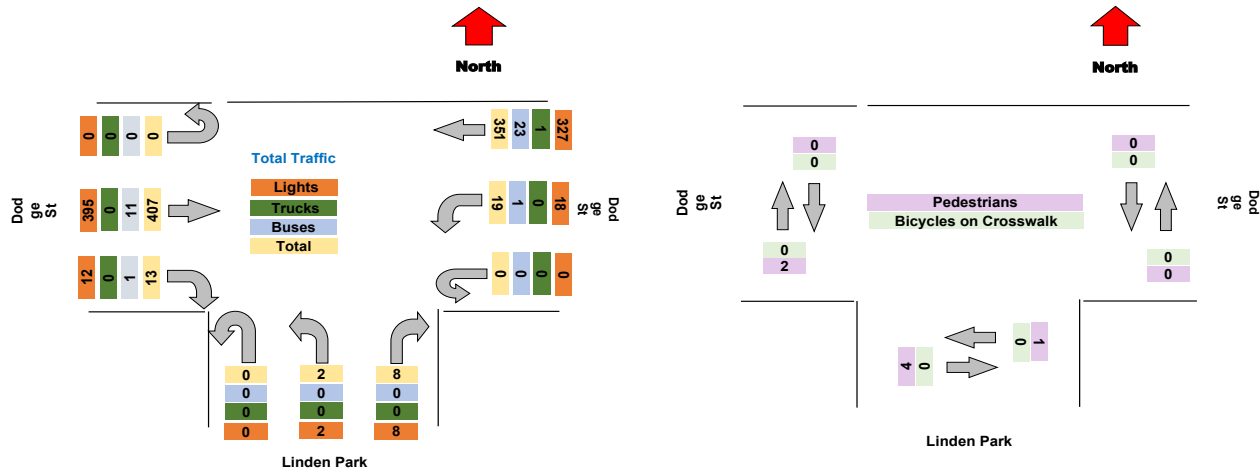

Turning Movement Peak Hour Data (AM)

7:30:00 AM

Leg Direction	Dodge St Westbound						Linden Park Northbound						Dodge St Eastbound						Total
	Thru	Left	U-Turn	App Total	Peds CW	Peds CCW	Right	Left	U-Turn	App Total	Peds CW	Peds CCW	Right	Thru	U-Turn	App Total	Peds CW	Peds CCW	
7:30:00 AM	16	1	0	17	0	0	0	0	0	0	0	0	0	15	0	15	0	0	32
7:45:00 AM	21	2	0	23	0	0	0	0	0	0	0	1	0	24	0	25	1	0	48
8:00:00 AM	21	0	0	21	0	0	1	1	0	2	0	0	1	20	0	21	0	0	44
8:15:00 AM	22	2	0	24	0	0	0	0	0	0	0	0	0	28	0	28	0	0	52
Grand Total	80	5	0	85	0	0	1	1	0	2	0	1	1	87	0	89	1	0	176
% Approach	94.1%	5.9%	0.0%	0.0%	0.0%	0.0%	14.2%	0.0%	0.0%	0.0%	0.0%	0.0%	45.1%	41.7%	0.0%	0.0%	0.0%	0.0%	
% Total	45.5%	2.8%	0.0%	48.3%	0.0%	0.0%	0.6%	0.6%	0.0%	1.1%	0.0%	0.0%	0.6%	49.4%	0.0%	50.6%	0.0%	0.0%	
PHF	0.909	0.625	0.000	0.885	0.000	0.000	0.250	0.250	0.000	0.250	0.000	0.000	0.250	0.777	0.000	0.795	0.000	0.000	0.846
Lights	72	5	0	77	0	0	1	1	0	2	0	0	1	84	0	85	0	0	164
% Lights	90.0%	100.0%	0.0%	90.6%	0.0%	0.0%	100.0%	100.0%	0.0%	100.0%	0.0%	0.0%	100.0%	96.6%	0.0%	95.5%	0.0%	0.0%	93.2%
Trucks	0	0	0	0	0	0	0	0	0	0	0	0	0	0	0	0	0	0	0
% Trucks	0.0%	0.0%	0.0%	0.0%	0.0%	0.0%	0.0%	0.0%	0.0%	0.0%	0.0%	0.0%	0.0%	0.0%	0.0%	0.0%	0.0%	0.0%	0.0%
Buses	8	0	0	8	0	0	0	0	0	0	0	0	0	3	0	3	0	0	11
% Buses	10.0%	0.0%	0.0%	0.0%	0.0%	0.0%	0.0%	0.0%	0.0%	0.0%	0.0%	0.0%	0.0%	3.4%	0.0%	0.0%	0.0%	0.0%	6.3%
Pedestrians	0	0	0	0	0	0	0	0	0	0	0	1	0	0	0	1	0	0	1
% Pedestrians	0.0%	0.0%	0.0%	0.0%	0.0%	0.0%	0.0%	0.0%	0.0%	0.0%	100.0%	0.0%	0.0%	0.0%	0.0%	0.0%	100.0%	0.0%	0.0%
Bicycles on Crosswalk	0	0	0	0	0	0	0	0	0	0	0	0	0	0	0	0	0	0	0
% Bicycles on Crosswalk	0.0%	0.0%	0.0%	0.0%	0.0%	0.0%	0.0%	0.0%	0.0%	0.0%	0.0%	0.0%	0.0%	0.0%	0.0%	0.0%	0.0%	0.0%	0.0%

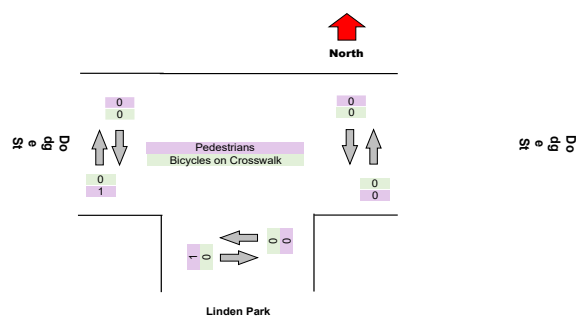
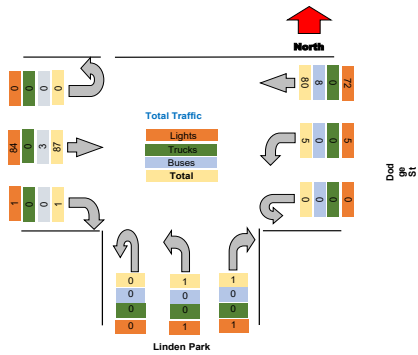

Turning Movement Peak Hour Data (PM)

4:30:00 PM

Leg Direction	Dodge St Westbound						Linden Park Northbound						Dodge St Eastbound						Total
	Thru	Left	U-Turn	App Total	Peds CW	Peds CCW	Right	Left	U-Turn	App Total	Peds CW	Peds CCW	Right	Thru	U-Turn	App Total	Peds CW	Peds CCW	
4:30:00 PM	27	0	0	27	0	0	0	0	0	0	0	0	1	37	0	38	1	0	65
4:45:00 PM	33	4	0	37	0	0	1	0	1	0	1	1	4	36	0	40	0	0	78
5:00:00 PM	22	1	0	23	0	0	0	0	0	0	0	1	31	0	32	0	0	55	
5:15:00 PM	33	0	0	33	0	0	1	0	1	0	0	0	0	37	0	37	0	0	71
Grand Total	115	5	0	120	0	0	2	0	2	0	1	6	141	0	147	1	0	269	
% Approach	95.8%	4.2%	0.0%	0.0%	0.0%	0.0%	14.2%	0.0%	0.0%	0.0%	0.0%	45.1%	41.7%	0.0%	0.0%	0.0%	0.0%	0.0%	
% Total	42.8%	1.9%	0.0%	44.6%	0.0%	0.0%	0.7%	0.0%	0.0%	0.7%	0.0%	2.2%	52.4%	0.0%	54.6%	0.0%	0.0%	0.0%	
PHF	0.871	0.313	0.000	0.811	0.000	0.000	0.500	0.000	0.000	0.500	0.000	0.375	0.953	0.000	0.919	0.000	0.000	0.862	
Lights	106	5	0	111	0	0	2	0	2	0	0	5	137	0	142	0	0	255	
% Lights	92.2%	100.0%	0.0%	92.5%	0.0%	0.0%	100.0%	0.0%	100.0%	0.0%	0.0%	83.3%	97.2%	0.0%	96.6%	0.0%	0.0%	94.8%	
Trucks	0	0	0	0	0	0	0	0	0	0	0	0	0	0	0	0	0	0	0
% Trucks	0.0%	0.0%	0.0%	0.0%	0.0%	0.0%	0.0%	0.0%	0.0%	0.0%	0.0%	0.0%	0.0%	0.0%	0.0%	0.0%	0.0%	0.0%	0.0%
Buses	9	0	0	9	0	0	0	0	0	0	0	1	3	0	4	0	0	13	
% Buses	7.8%	0.0%	0.0%	0.0%	0.0%	0.0%	0.0%	0.0%	0.0%	0.0%	0.0%	16.7%	2.1%	0.0%	0.0%	0.0%	0.0%	4.8%	
Pedestrians	0	0	0	0	0	0	0	0	0	0	1	0	0	0	1	0	0	0	
% Pedestrians	0.0%	0.0%	0.0%	0.0%	0.0%	0.0%	0.0%	0.0%	0.0%	0.0%	100.0%	0.0%	0.0%	0.0%	0.0%	100.0%	0.0%	0.0%	
Bicycles on Crosswalk	0	0	0	0	0	0	0	0	0	0	0	0	0	0	0	0	0	0	0
% Bicycles on Crosswalk	0.0%	0.0%	0.0%	0.0%	0.0%	0.0%	0.0%	0.0%	0.0%	0.0%	0.0%	0.0%	0.0%	0.0%	0.0%	0.0%	0.0%	0.0%	0.0%

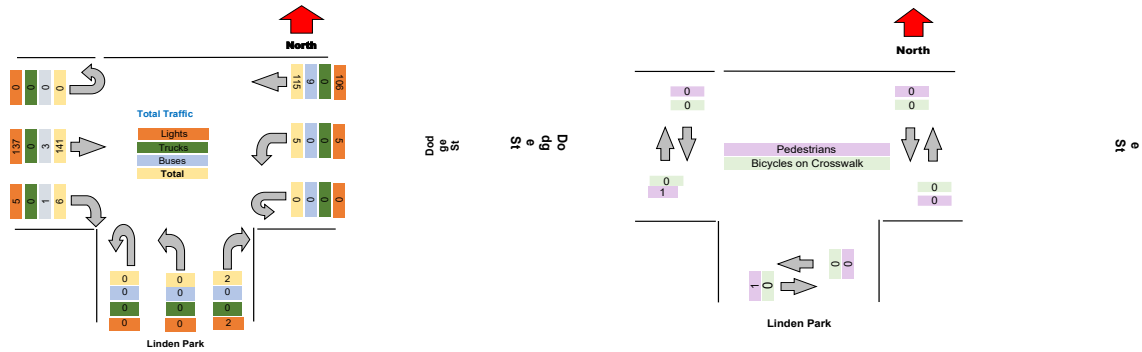

Turning Movement Data Plot

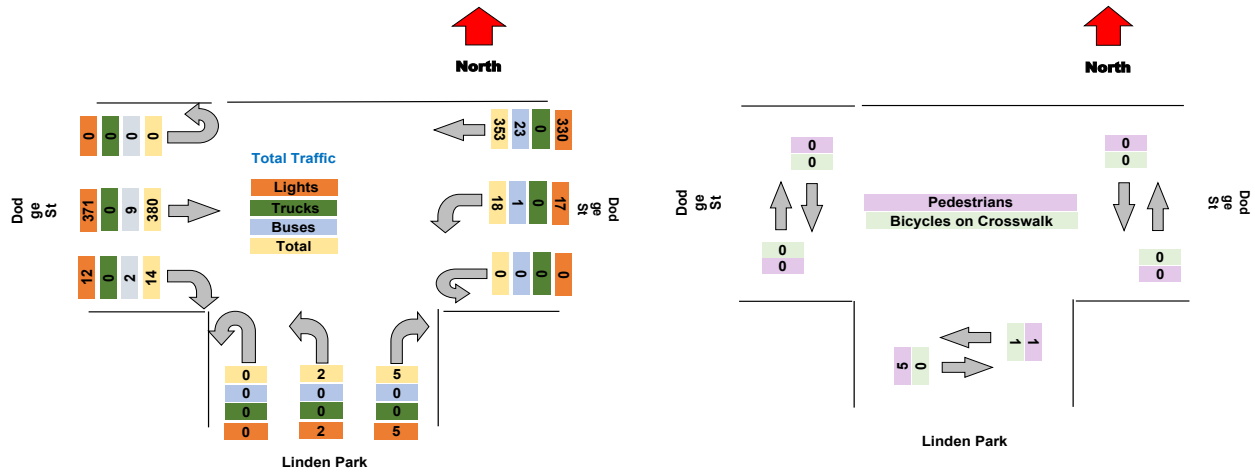

Turning Movement Peak Hour Data (AM)
7:30:00 AM

Leg Direction	Dodge St Westbound						Linden Park Northbound						Dodge St Eastbound						Total
	Thru	Left	U-Turn	App Total	Peds CW	Peds CCW	Right	Left	U-Turn	App Total	Peds CW	Peds CCW	Right	Thru	U-Turn	App Total	Peds CW	Peds CCW	
7:30:00 AM	11	2	0	13	0	0	0	0	0	0	0	0	0	13	0	13	0	0	26
7:45:00 AM	21	0	0	21	0	0	1	0	0	1	0	1	0	25	0	26	0	0	48
8:00:00 AM	23	0	0	23	0	0	3	0	0	3	0	0	0	18	0	18	0	0	44
8:15:00 AM	12	0	0	12	0	0	0	0	0	1	0	0	0	15	0	16	0	0	28
Grand Total	67	2	0	69	0	0	4	0	0	4	1	1	0	71	0	73	0	0	146
% Approach	97.1%	2.9%	0.0%	0.0%	0.0%	0.0%	14.2%	0.0%	0.0%	0.0%	0.0%	0.0%	45.1%	41.7%	0.0%	0.0%	0.0%	0.0%	
% Total	45.9%	1.4%	0.0%	47.3%	0.0%	0.0%	2.7%	0.0%	0.0%	2.7%	0.0%	0.0%	0.0%	48.6%	0.0%	50.0%	0.0%	0.0%	
PHF	0.728	0.250	0.000	0.750	0.000	0.000	0.333	0.000	0.000	0.333	0.000	0.000	0.000	0.710	0.000	0.702	0.000	0.000	0.760
Lights	57	2	0	59	0	0	4	0	0	4	0	0	0	69	0	69	0	0	132
% Lights	85.1%	100.0%	0.0%	85.5%	0.0%	0.0%	100.0%	0.0%	0.0%	100.0%	0.0%	0.0%	0.0%	97.2%	0.0%	94.5%	0.0%	0.0%	90.4%
Trucks	0	0	0	0	0	0	0	0	0	0	0	0	0	0	0	0	0	0	0
% Trucks	0.0%	0.0%	0.0%	0.0%	0.0%	0.0%	0.0%	0.0%	0.0%	0.0%	0.0%	0.0%	0.0%	0.0%	0.0%	0.0%	0.0%	0.0%	0.0%
Buses	10	0	0	10	0	0	0	0	0	0	0	0	0	2	0	2	0	0	12
% Buses	14.9%	0.0%	0.0%	0.0%	0.0%	0.0%	0.0%	0.0%	0.0%	0.0%	0.0%	0.0%	0.0%	2.8%	0.0%	0.0%	0.0%	0.0%	8.2%
Pedestrians	0	0	0	0	0	0	0	0	0	0	0	0	0	0	0	0	0	0	0
% Pedestrians	0.0%	0.0%	0.0%	0.0%	0.0%	0.0%	0.0%	0.0%	0.0%	0.0%	100.0%	0.0%	0.0%	0.0%	0.0%	0.0%	0.0%	0.0%	0.0%
Bicycles on Crosswalk	0	0	0	0	0	0	0	0	0	1	0	0	0	0	0	0	0	0	0
% Bicycles on Crosswalk	0.0%	0.0%	0.0%	0.0%	0.0%	0.0%	0.0%	0.0%	0.0%	0.0%	100.0%	0.0%	0.0%	0.0%	0.0%	0.0%	0.0%	0.0%	0.0%

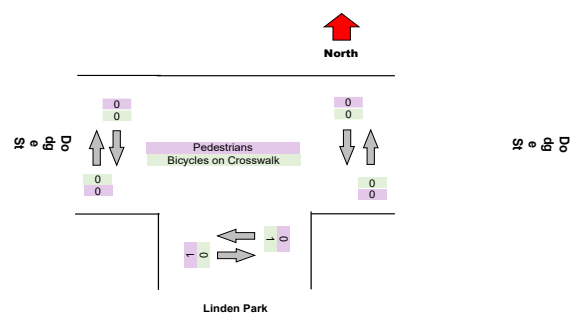
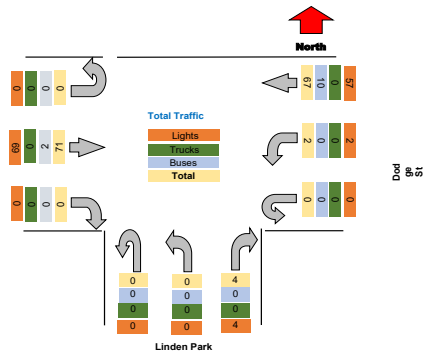

Turning Movement Peak Hour Data (PM)
4:30:00 PM

Leg Direction	Dodge St Westbound						Linden Park Northbound						Dodge St Eastbound						Total
	Thru	Left	U-Turn	App Total	Peds CW	Peds CCW	Right	Left	U-Turn	App Total	Peds CW	Peds CCW	Right	Thru	U-Turn	App Total	Peds CW	Peds CCW	
4:30:00 PM	38	2	0	40	0	0	0	0	0	0	0	0	1	35	0	36	0	0	76
4:45:00 PM	33	4	0	37	0	0	0	0	0	0	0	0	1	32	0	33	0	0	70
5:00:00 PM	24	2	0	26	0	0	0	0	0	0	2	2	30	0	32	0	0	58	
5:15:00 PM	31	2	0	33	0	0	0	1	1	0	0	2	34	0	36	0	0	70	
Grand Total	126	10	0	136	0	0	0	1	1	0	2	6	131	0	137	0	0	274	
% Approach	92.6%	7.4%	0.0%	0.0%	0.0%	0.0%	14.2%	0.0%	0.0%	0.0%	0.0%	45.1%	41.7%	0.0%	0.0%	0.0%	0.0%	0.0%	
% Total	46.0%	3.6%	0.0%	49.6%	0.0%	0.0%	0.0%	0.4%	0.0%	0.4%	0.0%	2.2%	47.8%	0.0%	50.0%	0.0%	0.0%	0.0%	
PHF	0.829	0.625	0.000	0.850	0.000	0.000	0.000	0.250	0.000	0.250	0.000	0.750	0.936	0.000	0.951	0.000	0.000	0.901	
Lights	117	9	0	126	0	0	0	1	0	1	0	4	129	0	133	0	0	260	
% Lights	92.9%	90.0%	0.0%	92.6%	0.0%	0.0%	0.0%	100.0%	0.0%	100.0%	0.0%	66.7%	98.5%	0.0%	97.1%	0.0%	0.0%	94.9%	
Trucks	0	0	0	0	0	0	0	0	0	0	0	0	0	0	0	0	0	0	
% Trucks	0.0%	0.0%	0.0%	0.0%	0.0%	0.0%	0.0%	0.0%	0.0%	0.0%	0.0%	0.0%	0.0%	0.0%	0.0%	0.0%	0.0%	0.0%	
Buses	9	1	0	10	0	0	0	0	0	0	0	2	2	0	4	0	0	14	
% Buses	7.1%	10.0%	0.0%	0.0%	0.0%	0.0%	0.0%	0.0%	0.0%	0.0%	0.0%	33.3%	1.5%	0.0%	0.0%	0.0%	0.0%	5.1%	
Pedestrians	0	0	0	0	0	0	0	0	0	0	2	0	0	0	0	0	0	0	
% Pedestrians	0.0%	0.0%	0.0%	0.0%	0.0%	0.0%	0.0%	0.0%	0.0%	0.0%	100.0%	0.0%	0.0%	0.0%	0.0%	0.0%	0.0%	0.0%	
Bicycles on Crosswalk	0	0	0	0	0	0	0	0	0	0	0	0	0	0	0	0	0	0	
% Bicycles on Crosswalk	0.0%	0.0%	0.0%	0.0%	0.0%	0.0%	0.0%	0.0%	0.0%	0.0%	0.0%	0.0%	0.0%	0.0%	0.0%	0.0%	0.0%	0.0%	

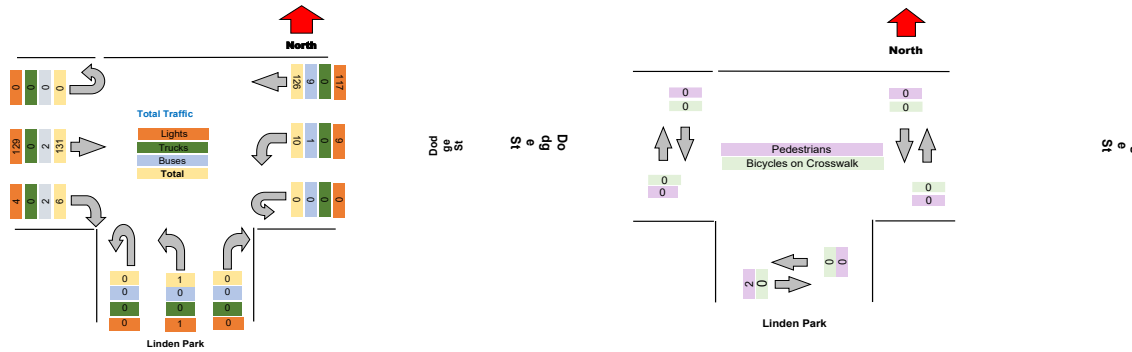

Turning Movement Data Plot

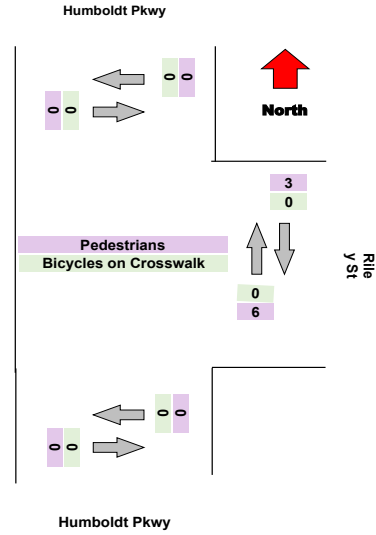
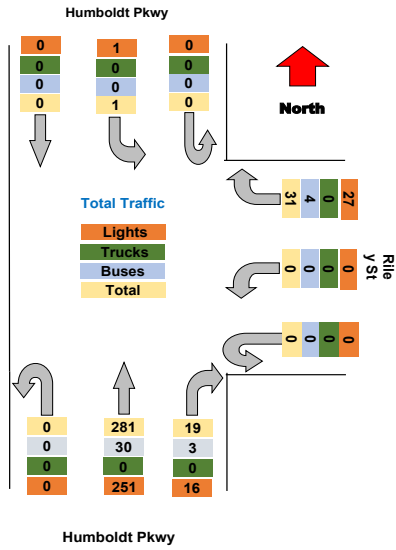

Turning Movement Peak Hour Data (AM)
 7:30:00 AM

Leg	Humboldt Pkwy						Riley St						Humboldt Pkwy						Total
	Southbound						Westbound						Northbound						
Direction	Thru	Left	U-Turn	App	Total	Peds CW/Peds CCW	Right	Left	U-Turn	App	Total	Peds CW/Peds CCW	Right	Thru	U-Turn	App	Total	Peds CW/Peds CCW	
7:30:00 AM	0	0	0	0	0	0	3	0	0	3	1	1	3	21	0	26	0	0	29
7:45:00 AM	0	0	0	0	0	0	1	0	0	1	0	0	0	19	0	19	0	0	20
8:00:00 AM	0	0	0	0	0	0	0	0	0	0	0	0	1	15	0	16	0	0	16
8:15:00 AM	0	1	0	1	0	0	3	0	0	3	0	0	1	12	0	13	0	0	17
Grand Total	0	1	0	1	0	0	7	0	0	7	1	1	5	67	0	74	0	0	82
% Approach	0.0%	100.0%	0.0%	0.0%	0.0%	0.0%	14.2%	0.0%	0.0%	0.0%	0.0%	0.0%	45.1%	41.7%	0.0%	0.0%	0.0%	0.0%	0.0%
% Total	0.0%	1.2%	0.0%	1.2%	0.0%	0.0%	8.5%	0.0%	0.0%	8.5%	0.0%	0.0%	6.1%	81.7%	0.0%	90.2%	0.0%	0.0%	0.0%
PHF	0.000	0.250	0.000	0.250	0.000	0.000	0.583	0.000	0.000	0.583	0.000	0.000	0.417	0.798	0.000	0.712	0.000	0.000	0.707
Lights	0	1	0	1	0	0	5	0	0	5	0	0	4	56	0	60	0	0	66
% Lights	0.0%	100.0%	0.0%	100.0%	0.0%	0.0%	71.4%	0.0%	0.0%	71.4%	0.0%	0.0%	80.0%	83.6%	0.0%	81.1%	0.0%	0.0%	80.5%
Trucks	0	0	0	0	0	0	0	0	0	0	0	0	0	0	0	0	0	0	0
% Trucks	0.0%	0.0%	0.0%	0.0%	0.0%	0.0%	0.0%	0.0%	0.0%	0.0%	0.0%	0.0%	0.0%	0.0%	0.0%	0.0%	0.0%	0.0%	0.0%
Buses	0	0	0	0	0	0	2	0	0	2	0	0	1	11	0	12	0	0	14
% Buses	0.0%	0.0%	0.0%	0.0%	0.0%	0.0%	28.6%	0.0%	0.0%	0.0%	0.0%	0.0%	20.0%	16.4%	0.0%	0.0%	0.0%	0.0%	17.1%
Pedestrians	0	0	0	0	0	0	0	0	0	0	1	1	0	0	0	0	0	0	0
% Pedestrians	0.0%	0.0%	0.0%	0.0%	0.0%	0.0%	0.0%	0.0%	0.0%	0.0%	100.0%	100.0%	0.0%	0.0%	0.0%	0.0%	0.0%	0.0%	0.0%
Bicycles on Crosswalk	0	0	0	0	0	0	0	0	0	0	0	0	0	0	0	0	0	0	0
% Bicycles on Crosswalk	0.0%	0.0%	0.0%	0.0%	0.0%	0.0%	0.0%	0.0%	0.0%	0.0%	0.0%	0.0%	0.0%	0.0%	0.0%	0.0%	0.0%	0.0%	0.0%

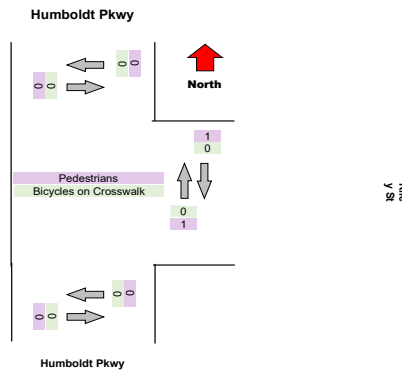
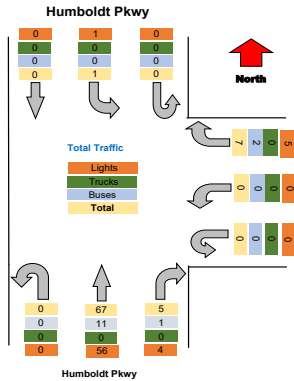

Turning Movement Peak Hour Data (PM)
 4:30:00 PM

Leg Direction	Humboldt Pkwy						Riley St						Humboldt Pkwy						Total			
	Southbound						Westbound						Northbound									
Start Time	Thru	Left	U-Turn	App	Total	Peds CW	Peds CCW	Right	Left	U-Turn	App	Total	Peds CW	Peds CCW	Right	Thru	U-Turn	App	Total	Peds CW	Peds CCW	
4:30:00 PM	0	0	0	0	0	0	0	1	0	0	1	1	0	0	24	0	24	0	0	25	0	0
4:45:00 PM	0	0	0	0	0	0	0	3	0	0	3	0	1	3	25	0	28	0	0	31	0	0
5:00:00 PM	0	0	0	0	0	0	0	0	0	0	0	1	0	0	21	0	21	0	0	21	0	0
5:15:00 PM	0	0	0	0	0	0	0	5	0	0	5	0	1	0	19	0	19	0	0	24	0	0
Grand Total	0	0	0	0	0	0	0	9	0	0	9	2	2	3	89	0	92	0	0	101	0	0
% Approach	#####	#DIV/0!	#####	0.0%	0.0%	0.0%	0.0%	14.2%	0.0%	0.0%	0.0%	0.0%	0.0%	0.0%	45.1%	41.7%	0.0%	0.0%	0.0%	0.0%	0.0%	0.0%
% Total	0.0%	0.0%	0.0%	0.0%	0.0%	0.0%	0.0%	8.9%	0.0%	0.0%	8.9%	0.0%	0.0%	0.0%	3.0%	88.1%	0.0%	91.1%	0.0%	0.0%	0.0%	0.0%
PHF	0.000	0.000	0.000	0.000	0.000	0.000	0.000	0.450	0.000	0.000	0.450	0.000	0.000	0.000	0.250	0.890	0.000	0.821	0.000	0.000	0.000	0.000
Lights	0	0	0	0	0	0	0	9	0	0	9	0	0	2	85	0	87	0	0	96	0	0
% Lights	0.0%	0.0%	0.0%	0.0%	0.0%	0.0%	0.0%	100.0%	0.0%	0.0%	100.0%	0.0%	0.0%	0.0%	66.7%	95.5%	0.0%	94.6%	0.0%	0.0%	0.0%	0.0%
Trucks	0	0	0	0	0	0	0	0	0	0	0	0	0	0	0	0	0	0	0	0	0	0
% Trucks	0.0%	0.0%	0.0%	0.0%	0.0%	0.0%	0.0%	0.0%	0.0%	0.0%	0.0%	0.0%	0.0%	0.0%	0.0%	0.0%	0.0%	0.0%	0.0%	0.0%	0.0%	0.0%
Buses	0	0	0	0	0	0	0	0	0	0	0	0	0	0	4	0	5	0	0	5	0	0
% Buses	0.0%	0.0%	0.0%	0.0%	0.0%	0.0%	0.0%	0.0%	0.0%	0.0%	0.0%	0.0%	0.0%	0.0%	33.3%	4.5%	0.0%	0.0%	0.0%	0.0%	0.0%	0.0%
Pedestrians	0	0	0	0	0	0	0	0	0	0	0	2	2	0	0	0	0	0	0	0	0	0
% Pedestrians	0.0%	0.0%	0.0%	0.0%	0.0%	0.0%	0.0%	0.0%	0.0%	0.0%	0.0%	100.0%	100.0%	100.0%	0.0%	0.0%	0.0%	0.0%	0.0%	0.0%	0.0%	0.0%
Bicycles on Crosswalk	0	0	0	0	0	0	0	0	0	0	0	0	0	0	0	0	0	0	0	0	0	0
% Bicycles on Crosswalk	0.0%	0.0%	0.0%	0.0%	0.0%	0.0%	0.0%	0.0%	0.0%	0.0%	0.0%	0.0%	0.0%	0.0%	0.0%	0.0%	0.0%	0.0%	0.0%	0.0%	0.0%	0.0%

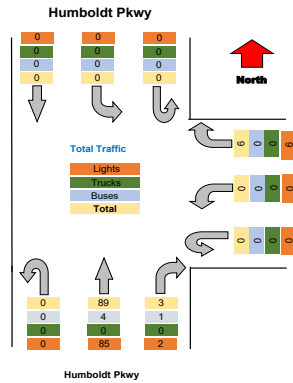

Riley St

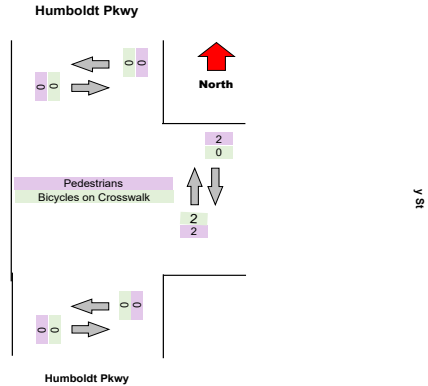

Turning Movement Data Plot

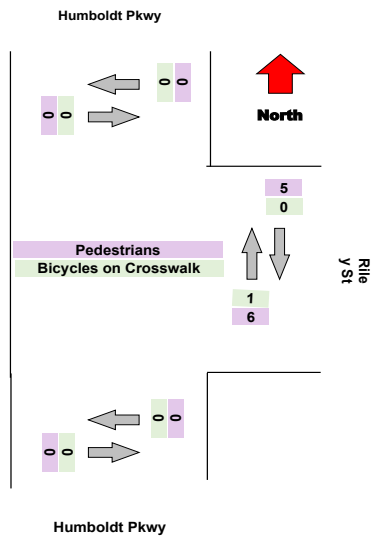
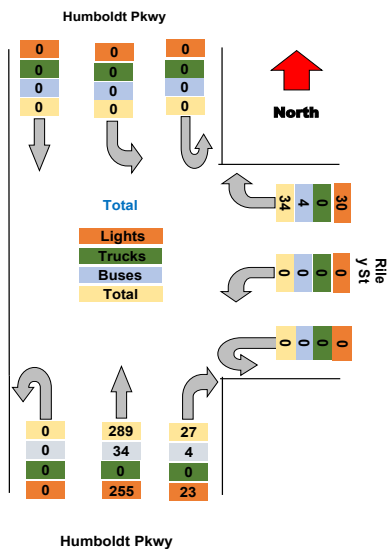

Turning Movement Peak Hour Data (AM)
 7:30:00 AM

Leg	Humboldt Pkwy						Riley St						Humboldt Pkwy						Total			
	Southbound						Westbound						Northbound									
Direction	Thru	Left	U-Turn	App	Total	Peds CW	Peds CCW	Right	Left	U-Turn	App	Total	Peds CW	Peds CCW	Right	Thru	U-Turn	App	Total	Peds CW	Peds CCW	
7:30:00 AM	0	0	0	0	0	0	0	1	0	0	1	0	0	0	3	17	0	20	0	0	0	0
7:45:00 AM	0	0	0	0	0	0	0	2	0	0	2	1	1	1	0	15	0	17	0	0	0	0
8:00:00 AM	0	0	0	0	0	0	0	2	0	0	2	0	0	0	1	18	0	19	0	0	0	0
8:15:00 AM	0	0	0	0	0	0	0	2	0	0	2	0	0	0	1	13	0	14	0	0	0	0
Grand Total	0	0	0	0	0	0	0	7	0	0	7	1	1	1	5	63	0	70	0	0	0	0
% Approach	#####	#####	#####	0.0%	0.0%	0.0%	0.0%	14.2%	0.0%	0.0%	0.0%	0.0%	0.0%	0.0%	45.1%	41.7%	0.0%	0.0%	0.0%	0.0%	0.0%	0.0%
% Total	0.0%	0.0%	0.0%	0.0%	0.0%	0.0%	0.0%	9.1%	0.0%	0.0%	9.1%	0.0%	0.0%	0.0%	6.5%	81.8%	0.0%	90.9%	0.0%	0.0%	0.0%	0.0%
PHF	0.000	0.000	0.000	0.000	0.000	0.000	0.000	0.875	0.000	0.000	0.875	0.000	0.000	0.000	0.417	0.875	0.000	0.875	0.000	0.000	0.000	0.000
Lights	0	0	0	0	0	0	0	5	0	0	5	0	0	0	3	53	0	56	0	0	0	0
% Lights	0.0%	0.0%	0.0%	0.0%	0.0%	0.0%	0.0%	71.4%	0.0%	0.0%	71.4%	0.0%	0.0%	0.0%	60.0%	84.1%	0.0%	80.0%	0.0%	0.0%	0.0%	0.0%
Trucks	0	0	0	0	0	0	0	0	0	0	0	0	0	0	0	0	0	0	0	0	0	0
% Trucks	0.0%	0.0%	0.0%	0.0%	0.0%	0.0%	0.0%	0.0%	0.0%	0.0%	0.0%	0.0%	0.0%	0.0%	0.0%	0.0%	0.0%	0.0%	0.0%	0.0%	0.0%	0.0%
Buses	0	0	0	0	0	0	0	2	0	0	2	0	0	0	2	10	0	12	0	0	0	0
% Buses	0.0%	0.0%	0.0%	0.0%	0.0%	0.0%	0.0%	28.6%	0.0%	0.0%	28.6%	0.0%	0.0%	0.0%	40.0%	15.9%	0.0%	17.1%	0.0%	0.0%	0.0%	0.0%
Pedestrians	0	0	0	0	0	0	0	0	0	0	0	1	1	1	0	0	0	0	0	0	0	0
% Pedestrians	0.0%	0.0%	0.0%	0.0%	0.0%	0.0%	0.0%	0.0%	0.0%	0.0%	0.0%	100.0%	100.0%	100.0%	0.0%	0.0%	0.0%	0.0%	0.0%	0.0%	0.0%	0.0%
Bicycles on Crosswalk	0	0	0	0	0	0	0	0	0	0	0	0	0	0	0	0	0	0	0	0	0	0
% Bicycles on Crosswalk	0.0%	0.0%	0.0%	0.0%	0.0%	0.0%	0.0%	0.0%	0.0%	0.0%	0.0%	0.0%	0.0%	0.0%	0.0%	0.0%	0.0%	0.0%	0.0%	0.0%	0.0%	0.0%

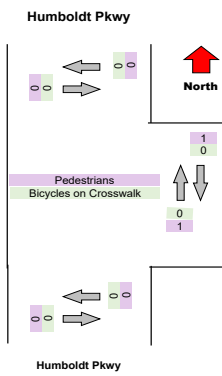
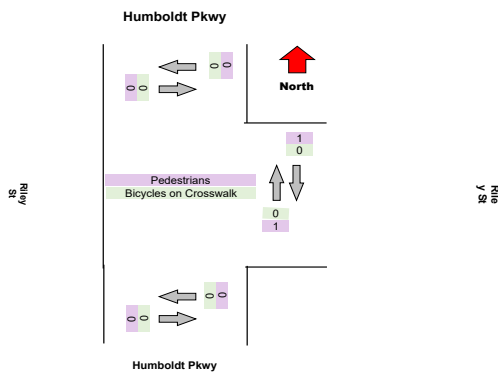
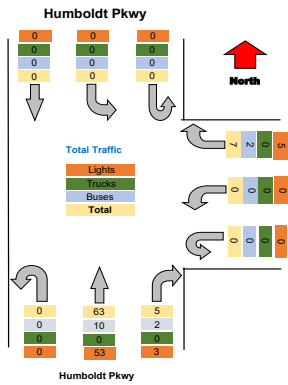

Turning Movement Peak Hour Data (PM)
 4:30:00 PM

Leg Direction	Humboldt Pkwy Southbound						Riley St Westbound						Humboldt Pkwy Northbound						Total
	Thru	Left	U-Turn	App Total	Peds CW	Peds CCW	Right	Left	U-Turn	App Total	Peds CW	Peds CCW	Right	Thru	U-Turn	App Total	Peds CW	Peds CCW	
4:30:00 PM	0	0	0	0	0	0	3	0	0	3	0	0	1	16	0	17	0	0	20
4:45:00 PM	0	0	0	0	0	0	3	0	0	3	0	0	4	23	0	27	0	0	30
5:00:00 PM	0	0	0	0	0	0	1	0	0	1	0	0	1	21	0	22	0	0	23
5:15:00 PM	0	0	0	0	0	0	2	0	0	2	1	4	2	23	0	25	0	0	27
Grand Total	0	0	0	0	0	0	9	0	0	9	1	4	8	83	0	91	0	0	100
% Approach	#####	#####	#####	0.0%	0.0%	0.0%	14.2%	0.0%	0.0%	0.0%	0.0%	0.0%	45.1%	41.7%	0.0%	0.0%	0.0%	0.0%	
% Total	0.0%	0.0%	0.0%	0.0%	0.0%	0.0%	9.0%	0.0%	0.0%	9.0%	0.0%	0.0%	8.0%	83.0%	0.0%	91.0%	0.0%	0.0%	
PHF	0.000	0.000	0.000	0.000	0.000	0.000	0.750	0.000	0.000	0.750	0.000	0.000	0.500	0.902	0.000	0.843	0.000	0.000	0.833
Lights	0	0	0	0	0	0	9	0	0	9	0	0	7	79	0	86	0	0	95
% Lights	0.0%	0.0%	0.0%	0.0%	0.0%	0.0%	100.0%	0.0%	0.0%	100.0%	0.0%	0.0%	87.5%	95.2%	0.0%	94.5%	0.0%	0.0%	95.0%
Trucks	0	0	0	0	0	0	0	0	0	0	0	0	0	0	0	0	0	0	0
% Trucks	0.0%	0.0%	0.0%	0.0%	0.0%	0.0%	0.0%	0.0%	0.0%	0.0%	0.0%	0.0%	0.0%	0.0%	0.0%	0.0%	0.0%	0.0%	0.0%
Buses	0	0	0	0	0	0	0	0	0	0	0	0	1	4	0	5	0	0	5
% Buses	0.0%	0.0%	0.0%	0.0%	0.0%	0.0%	0.0%	0.0%	0.0%	0.0%	0.0%	0.0%	12.5%	4.8%	0.0%	0.0%	0.0%	0.0%	5.0%
Pedestrians	0	0	0	0	0	0	0	0	0	0	1	4	0	0	0	0	0	0	0
% Pedestrians	0.0%	0.0%	0.0%	0.0%	0.0%	0.0%	0.0%	0.0%	0.0%	0.0%	100.0%	100.0%	0.0%	0.0%	0.0%	0.0%	0.0%	0.0%	0.0%
Bicycles on Crosswalk	0	0	0	0	0	0	0	0	0	0	0	0	0	0	0	0	0	0	0
% Bicycles on Crosswalk	0.0%	0.0%	0.0%	0.0%	0.0%	0.0%	0.0%	0.0%	0.0%	0.0%	0.0%	0.0%	0.0%	0.0%	0.0%	0.0%	0.0%	0.0%	0.0%

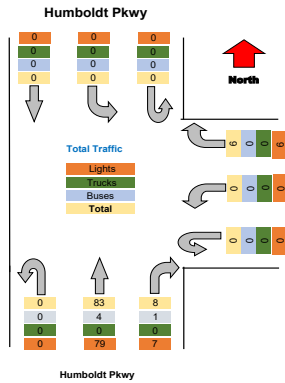

Riley St

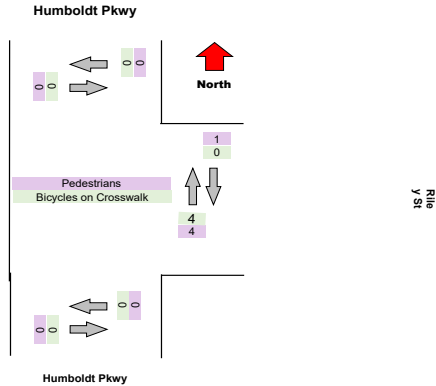

Riley St

Turning Movement Data Plot

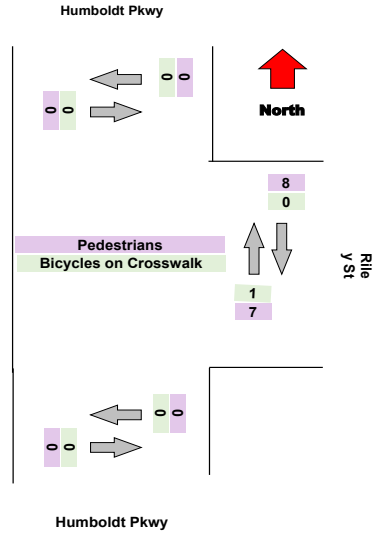
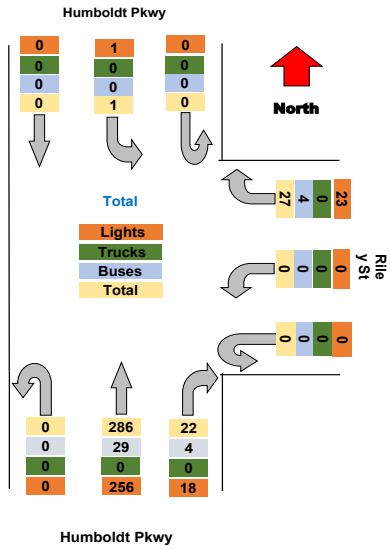

Turning Movement Peak Hour Data (AM)
 7:30:00 AM

Leg	Humboldt Pkwy						Riley St						Humboldt Pkwy						Total										
	Southbound						Westbound						Northbound																
Direction	Thru	Left	U-Turn	App	Total	Peds	CW	Peds	CCW	Right	Left	U-Turn	App	Total	Peds	CW	Peds	CCW	Right	Thru	U-Turn	App	Total	Peds	CW	Peds	CCW		
7:30:00 AM	0	0	0	0	0	0	0	0	0	1	0	0	1	0	0	1	0	0	0	1	13	0	14	0	0	15	0	0	0
7:45:00 AM	0	0	0	0	0	0	0	0	0	1	0	0	1	1	1	1	0	0	0	1	27	0	30	0	0	31	0	0	0
8:00:00 AM	0	1	0	1	0	0	0	0	0	1	0	0	1	0	0	1	0	0	0	2	24	0	26	0	0	28	0	0	0
8:15:00 AM	0	0	0	0	0	0	0	0	0	0	0	0	0	0	0	0	0	0	1	16	0	17	0	0	17	0	0	0	
Grand Total	0	1	0	1	0	0	0	0	0	3	0	0	3	1	1	1	0	0	5	80	0	87	0	0	91	0	0	0	
% Approach	0.0%	#####	0.0%	0.0%	0.0%	0.0%	0.0%	0.0%	0.0%	14.2%	0.0%	0.0%	0.0%	0.0%	0.0%	0.0%	0.0%	0.0%	45.1%	41.7%	0.0%	0.0%	0.0%	0.0%	0.0%	0.0%	0.0%	0.0%	
% Total	0.0%	1.1%	0.0%	1.1%	0.0%	0.0%	0.0%	0.0%	0.0%	3.3%	0.0%	0.0%	3.3%	0.0%	0.0%	0.0%	0.0%	0.0%	5.5%	87.9%	0.0%	0.0%	0.0%	0.0%	95.6%	0.0%	0.0%	0.0%	
PHF	0.000	0.250	0.000	0.250	0.000	0.000	0.000	0.000	0.000	0.750	0.000	0.000	0.750	0.000	0.000	0.000	0.000	0.000	0.625	0.741	0.000	0.725	0.000	0.000	0.734	0.000	0.000	0.000	
Lights	0	1	0	1	0	0	0	0	0	2	0	0	2	0	0	2	0	0	0	3	69	0	72	0	0	75	0	0	0
% Lights	0.0%	#####	0.0%	100.0%	0.0%	0.0%	0.0%	0.0%	0.0%	66.7%	0.0%	0.0%	66.7%	0.0%	0.0%	0.0%	0.0%	0.0%	60.0%	86.3%	0.0%	82.8%	0.0%	0.0%	82.4%	0.0%	0.0%	0.0%	
Trucks	0	0	0	0	0	0	0	0	0	0	0	0	0	0	0	0	0	0	0	0	0	0	0	0	0	0	0	0	0
% Trucks	0.0%	0.0%	0.0%	0.0%	0.0%	0.0%	0.0%	0.0%	0.0%	0.0%	0.0%	0.0%	0.0%	0.0%	0.0%	0.0%	0.0%	0.0%	0.0%	0.0%	0.0%	0.0%	0.0%	0.0%	0.0%	0.0%	0.0%	0.0%	
Buses	0	0	0	0	0	0	0	0	0	1	0	0	1	0	0	1	0	0	0	2	11	0	13	0	0	14	0	0	0
% Buses	0.0%	0.0%	0.0%	0.0%	0.0%	0.0%	0.0%	0.0%	0.0%	33.3%	0.0%	0.0%	0.0%	0.0%	0.0%	0.0%	0.0%	0.0%	40.0%	13.8%	0.0%	0.0%	0.0%	0.0%	15.4%	0.0%	0.0%	0.0%	
Pedestrians	0	0	0	0	0	0	0	0	0	0	0	0	0	1	1	0	0	0	0	0	0	0	0	0	0	0	0	0	0
% Pedestrians	0.0%	0.0%	0.0%	0.0%	0.0%	0.0%	0.0%	0.0%	0.0%	0.0%	0.0%	0.0%	0.0%	100.0%	100.0%	0.0%	0.0%	0.0%	0.0%	0.0%	0.0%	0.0%	0.0%	0.0%	0.0%	0.0%	0.0%	0.0%	
Bicycles on Crosswalk	0	0	0	0	0	0	0	0	0	0	0	0	0	0	0	0	0	0	0	0	0	0	0	0	0	0	0	0	0
% Bicycles on Crosswalk	0.0%	0.0%	0.0%	0.0%	0.0%	0.0%	0.0%	0.0%	0.0%	0.0%	0.0%	0.0%	0.0%	0.0%	0.0%	0.0%	0.0%	0.0%	0.0%	0.0%	0.0%	0.0%	0.0%	0.0%	0.0%	0.0%	0.0%	0.0%	

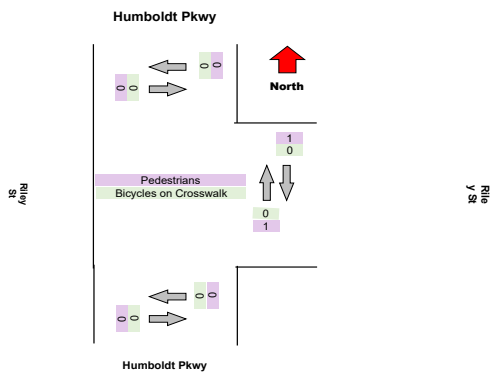
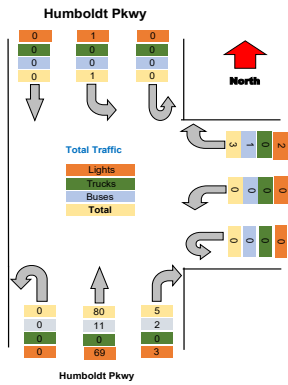

Turning Movement Peak Hour Data (PM)

4:30:00 PM

Leg Direction	Humboldt Pkwy Southbound						Riley St Westbound						Humboldt Pkwy Northbound						Total
	Thru	Left	U-Turn	App Total	Peds CW	Peds CCW	Right	Left	U-Turn	App Total	Peds CW	Peds CCW	Right	Thru	U-Turn	App Total	Peds CW	Peds CCW	
4:30:00 PM	0	0	0	0	0	0	6	0	0	6	0	0	2	25	0	27	0	0	33
4:45:00 PM	0	0	0	0	0	0	3	0	0	3	0	0	3	16	0	19	0	0	22
5:00:00 PM	0	0	0	0	0	0	3	0	0	3	1	1	3	18	0	21	0	0	24
5:15:00 PM	0	0	0	0	0	0	3	0	0	3	1	1	1	24	0	25	0	0	28
Grand Total	0	0	0	0	0	0	15	0	0	15	2	2	9	83	0	92	0	0	107
% Approach	#####	#####	#####	0.0%	0.0%	0.0%	14.2%	0.0%	0.0%	0.0%	0.0%	0.0%	45.1%	41.7%	0.0%	0.0%	0.0%	0.0%	
% Total	0.0%	0.0%	0.0%	0.0%	0.0%	0.0%	14.0%	0.0%	0.0%	14.0%	0.0%	0.0%	8.4%	77.6%	0.0%	86.0%	0.0%	0.0%	
PHF	0.000	0.000	0.000	0.000	0.000	0.000	0.625	0.000	0.000	0.625	0.000	0.000	0.750	0.830	0.000	0.852	0.000	0.000	0.811
Lights	0	0	0	0	0	0	14	0	0	14	0	0	8	79	0	87	0	0	101
% Lights	0.0%	0.0%	0.0%	0.0%	0.0%	0.0%	93.3%	0.0%	0.0%	93.3%	0.0%	0.0%	88.9%	95.2%	0.0%	94.6%	0.0%	0.0%	94.4%
Trucks	0	0	0	0	0	0	0	0	0	0	0	0	0	0	0	0	0	0	0
% Trucks	0.0%	0.0%	0.0%	0.0%	0.0%	0.0%	0.0%	0.0%	0.0%	0.0%	0.0%	0.0%	0.0%	0.0%	0.0%	0.0%	0.0%	0.0%	0.0%
Buses	0	0	0	0	0	0	1	0	0	1	0	0	1	4	0	5	0	0	6
% Buses	0.0%	0.0%	0.0%	0.0%	0.0%	0.0%	6.7%	0.0%	0.0%	6.7%	0.0%	0.0%	11.1%	4.8%	0.0%	16.9%	0.0%	0.0%	5.6%
Pedestrians	0	0	0	0	0	0	0	0	0	2	1	0	0	0	0	0	0	0	3
% Pedestrians	0.0%	0.0%	0.0%	0.0%	0.0%	0.0%	0.0%	0.0%	0.0%	13.3%	50.0%	0.0%	0.0%	0.0%	0.0%	0.0%	0.0%	0.0%	3.7%
Bicycles on Crosswalk	0	0	0	0	0	0	0	0	0	0	1	0	0	0	0	0	0	0	1
% Bicycles on Crosswalk	0.0%	0.0%	0.0%	0.0%	0.0%	0.0%	0.0%	0.0%	0.0%	0.0%	50.0%	0.0%	0.0%	0.0%	0.0%	0.0%	0.0%	0.0%	1.1%

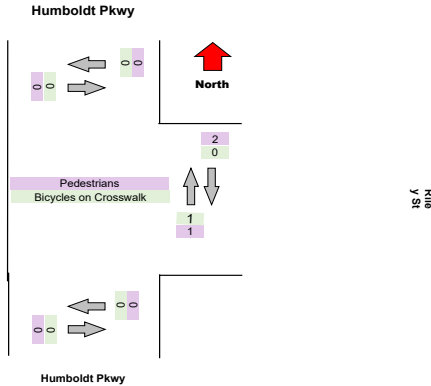
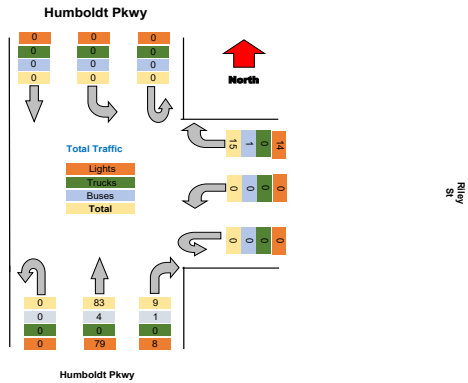

Turning Movement Data Plot

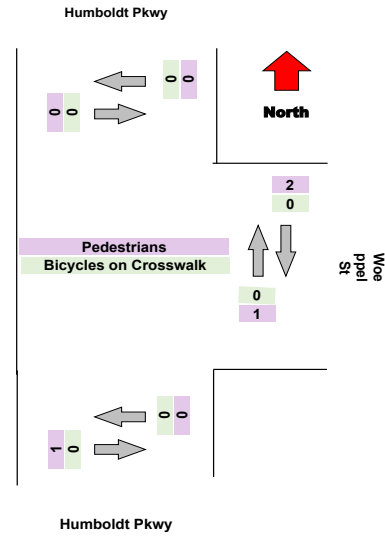
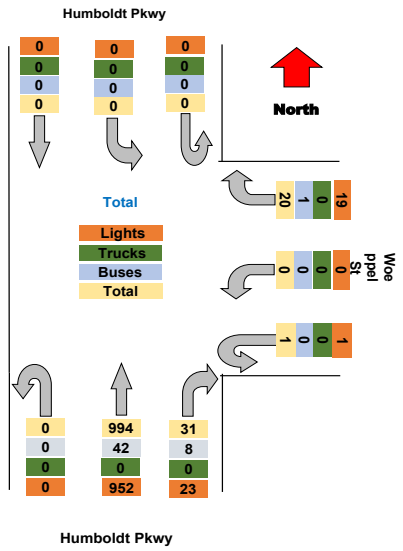

Turning Movement Peak Hour Data (AM)

7:30:00 AM

Leg Direction	Humboldt Pkwy Southbound						Woepfel St Westbound						Humboldt Pkwy Northbound						Total
	Thru	Left	U-Turn	App Total	Peds CW	Peds CCW	Right	Left	U-Turn	App Total	Peds CW	Peds CCW	Right	Thru	U-Turn	App Total	Peds CW	Peds CCW	
7:30:00 AM	0	0	0	0	0	0	1	0	1	2	0	0	1	57	0	58	0	0	60
7:45:00 AM	0	0	0	0	0	0	2	0	0	2	0	0	3	65	0	68	0	0	70
8:00:00 AM	0	0	0	0	0	0	1	0	0	1	0	0	0	62	0	62	0	0	63
8:15:00 AM	0	0	0	0	0	0	1	0	0	1	1	1	2	70	0	74	0	0	75
Grand Total	0	0	0	0	0	0	5	0	1	6	1	1	6	254	0	262	0	0	268
% Approach	#####	#####	#####	0.0%	0.0%	0.0%	14.2%	0.0%	0.0%	0.0%	0.0%	0.0%	45.1%	41.7%	0.0%	0.0%	0.0%	0.0%	
% Total	0.0%	0.0%	0.0%	0.0%	0.0%	0.0%	1.9%	0.0%	0.4%	2.2%	0.0%	0.0%	2.2%	94.8%	0.0%	97.8%	0.0%	0.0%	
PHF	0.000	0.000	0.000	0.000	0.000	0.000	0.625	0.000	0.250	0.750	0.000	0.000	0.500	0.907	0.000	0.885	0.000	0.000	0.893
Lights	0	0	0	0	0	0	5	0	1	6	0	0	2	241	0	243	0	0	249
% Lights	0.0%	0.0%	0.0%	0.0%	0.0%	0.0%	#####	0.0%	100.0%	100.0%	0.0%	0.0%	33.3%	94.9%	0.0%	92.7%	0.0%	0.0%	92.9%
Trucks	0	0	0	0	0	0	0	0	0	0	0	0	0	0	0	0	0	0	0
% Trucks	0.0%	0.0%	0.0%	0.0%	0.0%	0.0%	0.0%	0.0%	0.0%	0.0%	0.0%	0.0%	0.0%	0.0%	0.0%	0.0%	0.0%	0.0%	0.0%
Buses	0	0	0	0	0	0	0	0	0	0	0	0	4	13	0	17	0	0	17
% Buses	0.0%	0.0%	0.0%	0.0%	0.0%	0.0%	0.0%	0.0%	0.0%	0.0%	0.0%	0.0%	66.7%	5.1%	0.0%	0.0%	0.0%	0.0%	6.3%
Pedestrians	0	0	0	0	0	0	0	0	0	0	1	1	0	0	0	0	0	0	0
% Pedestrians	0.0%	0.0%	0.0%	0.0%	0.0%	0.0%	0.0%	0.0%	0.0%	0.0%	100.0%	100.0%	0.0%	0.0%	0.0%	0.0%	0.0%	0.0%	0.0%
Bicycles on Crosswalk	0	0	0	0	0	0	0	0	0	0	0	0	0	0	0	0	0	0	0
% Bicycles on Crosswalk	0.0%	0.0%	0.0%	0.0%	0.0%	0.0%	0.0%	0.0%	0.0%	0.0%	0.0%	0.0%	0.0%	0.0%	0.0%	0.0%	0.0%	0.0%	0.0%

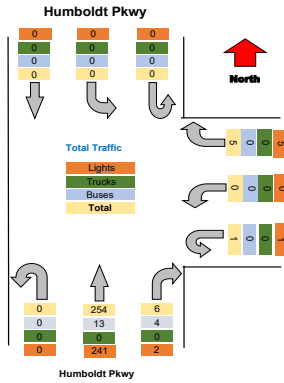

Woepfel St

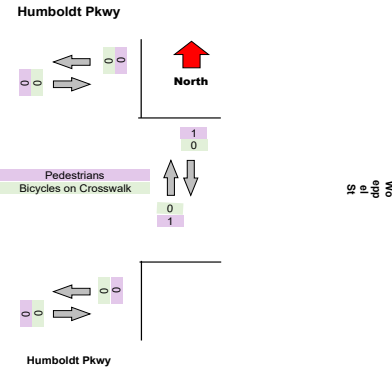

Turning Movement Peak Hour Data (PM)
 4:15:00 PM

Leg Direction	Humboldt Pkwy Southbound						Woepfel St Westbound						Humboldt Pkwy Northbound						Total
	Thru	Left	U-Turn	App Total	Peds CW	Peds CCW	Right	Left	U-Turn	App Total	Peds CW	Peds CCW	Right	Thru	U-Turn	App Total	Peds CW	Peds CCW	
4:15:00 PM	0	0	0	0	0	0	4	0	0	4	0	0	2	72	0	74	0	1	78
4:30:00 PM	0	0	0	0	0	0	1	0	0	1	0	0	2	64	0	66	0	0	67
4:45:00 PM	0	0	0	0	0	0	1	0	0	1	0	0	4	75	0	79	0	0	80
5:00:00 PM	0	0	0	0	0	0	1	0	0	1	0	0	4	77	0	81	0	0	82
Grand Total	0	0	0	0	0	0	7	0	0	7	0	0	12	288	0	300	0	1	307
% Approach	#####	#####	#####	0.0%	0.0%	0.0%	14.2%	0.0%	0.0%	0.0%	0.0%	0.0%	45.1%	41.7%	0.0%	0.0%	0.0%	0.0%	
% Total	0.0%	0.0%	0.0%	0.0%	0.0%	0.0%	2.3%	0.0%	0.0%	2.3%	0.0%	0.0%	3.9%	93.8%	0.0%	97.7%	0.0%	0.0%	
PHF	0.000	0.000	0.000	0.000	0.000	0.000	0.438	0.000	0.000	0.438	0.000	0.000	0.750	0.935	0.000	0.926	0.000	0.000	0.936
Lights	0	0	0	0	0	0	6	0	0	6	0	0	10	276	0	286	0	0	292
% Lights	0.0%	0.0%	0.0%	0.0%	0.0%	0.0%	85.7%	0.0%	0.0%	85.7%	0.0%	0.0%	83.3%	95.8%	0.0%	95.3%	0.0%	0.0%	95.1%
Trucks	0	0	0	0	0	0	0	0	0	0	0	0	0	0	0	0	0	0	0
% Trucks	0.0%	0.0%	0.0%	0.0%	0.0%	0.0%	0.0%	0.0%	0.0%	0.0%	0.0%	0.0%	0.0%	0.0%	0.0%	0.0%	0.0%	0.0%	0.0%
Buses	0	0	0	0	0	0	1	0	0	1	0	0	2	12	0	14	0	0	15
% Buses	0.0%	0.0%	0.0%	0.0%	0.0%	0.0%	14.3%	0.0%	0.0%	0.0%	0.0%	0.0%	16.7%	4.2%	0.0%	0.0%	0.0%	0.0%	4.9%
Pedestrians	0	0	0	0	0	0	0	0	0	0	0	0	0	0	0	0	0	1	0
% Pedestrians	0.0%	0.0%	0.0%	0.0%	0.0%	0.0%	0.0%	0.0%	0.0%	0.0%	0.0%	0.0%	0.0%	0.0%	0.0%	0.0%	0.0%	100.0%	0.0%
Bicycles on Crosswalk	0	0	0	0	0	0	0	0	0	0	0	0	0	0	0	0	0	0	0
% Bicycles on Crosswalk	0.0%	0.0%	0.0%	0.0%	0.0%	0.0%	0.0%	0.0%	0.0%	0.0%	0.0%	0.0%	0.0%	0.0%	0.0%	0.0%	0.0%	0.0%	0.0%

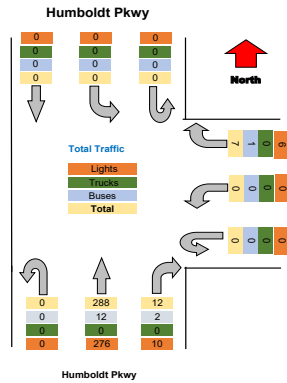

View
from
East

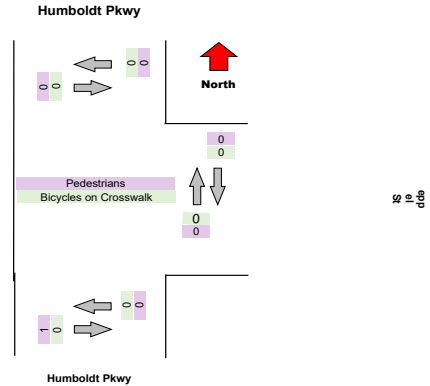

View
from
West

Turning Movement Data Plot

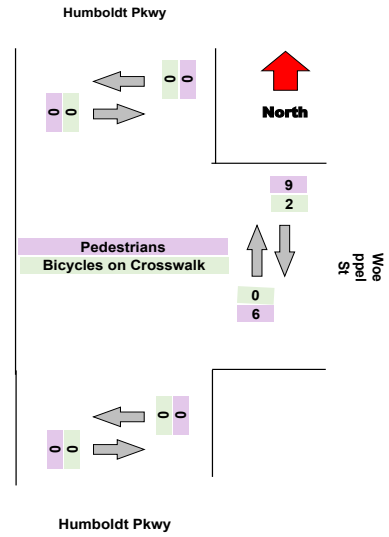
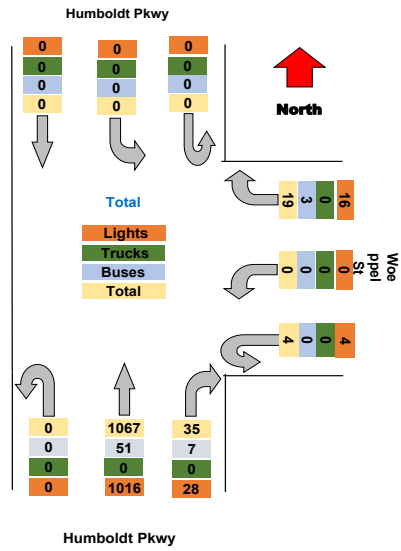

Turning Movement Peak Hour Data (AM)
 7:30:00 AM

Leg Direction	Humboldt Pkwy Southbound						Woepfel St Westbound						Humboldt Pkwy Northbound						Total
	Thru	Left	U-Turn	App Total	Peds CW	Peds CCW	Right	Left	U-Turn	App Total	Peds CW	Peds CCW	Right	Thru	U-Turn	App Total	Peds CW	Peds CCW	
7:30:00 AM	0	0	0	0	0	0	0	0	1	1	2	2	1	53	0	58	0	0	59
7:45:00 AM	0	0	0	0	0	0	0	0	0	0	0	0	1	69	0	70	0	0	70
8:00:00 AM	0	0	0	0	0	0	1	0	0	1	1	0	1	83	0	85	0	0	86
8:15:00 AM	0	0	0	0	0	0	3	0	0	3	0	0	2	47	0	49	0	0	52
Grand Total	0	0	0	0	0	0	4	0	1	5	3	2	5	252	0	262	0	0	267
% Approach	#####	#####	#####	0.0%	0.0%	0.0%	14.2%	0.0%	0.0%	0.0%	0.0%	0.0%	45.1%	41.7%	0.0%	0.0%	0.0%	0.0%	
% Total	0.0%	0.0%	0.0%	0.0%	0.0%	0.0%	1.5%	0.0%	0.4%	1.9%	0.0%	0.0%	1.9%	94.4%	0.0%	98.1%	0.0%	0.0%	
PHF	0.000	0.000	0.000	0.000	0.000	0.000	0.333	0.000	0.250	0.417	0.000	0.000	0.625	0.759	0.000	0.771	0.000	0.000	0.776
Lights	0	0	0	0	0	0	4	0	1	5	0	2	2	238	0	240	0	0	245
% Lights	0.0%	0.0%	0.0%	0.0%	0.0%	0.0%	100.0%	0.0%	100.0%	100.0%	0.0%	0.0%	40.0%	94.4%	0.0%	91.6%	0.0%	0.0%	91.8%
Trucks	0	0	0	0	0	0	0	0	0	0	0	0	0	0	0	0	0	0	0
% Trucks	0.0%	0.0%	0.0%	0.0%	0.0%	0.0%	0.0%	0.0%	0.0%	0.0%	0.0%	0.0%	0.0%	0.0%	0.0%	0.0%	0.0%	0.0%	0.0%
Buses	0	0	0	0	0	0	0	0	0	0	0	0	3	14	0	17	0	0	17
% Buses	0.0%	0.0%	0.0%	0.0%	0.0%	0.0%	0.0%	0.0%	0.0%	0.0%	0.0%	0.0%	60.0%	5.6%	0.0%	0.0%	0.0%	0.0%	6.4%
Pedestrians	0	0	0	0	0	0	0	0	0	0	3	2	0	0	0	0	0	0	0
% Pedestrians	0.0%	0.0%	0.0%	0.0%	0.0%	0.0%	0.0%	0.0%	0.0%	0.0%	100.0%	100.0%	0.0%	0.0%	0.0%	0.0%	0.0%	0.0%	0.0%
Bicycles on Crosswalk	0	0	0	0	0	0	0	0	0	0	0	0	0	0	0	0	0	0	0
% Bicycles on Crosswalk	0.0%	0.0%	0.0%	0.0%	0.0%	0.0%	0.0%	0.0%	0.0%	0.0%	0.0%	0.0%	0.0%	0.0%	0.0%	0.0%	0.0%	0.0%	0.0%

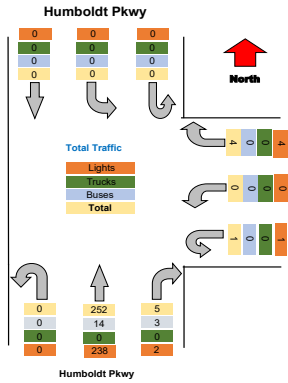

Woepfel St

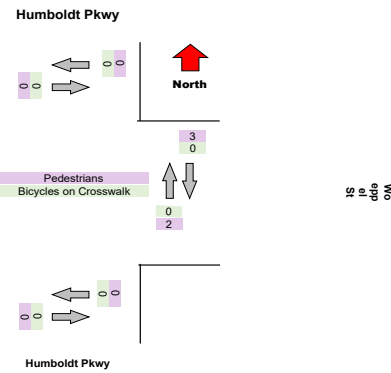

Woepfel St

Turning Movement Peak Hour Data (PM)
 4:15:00 PM

Leg Direction	Humboldt Pkwy Southbound						Woepfel St Westbound						Humboldt Pkwy Northbound						Total
	Thru	Left	U-Turn	App Total	Peds CW	Peds CCW	Right	Left	U-Turn	App Total	Peds CW	Peds CCW	Right	Thru	U-Turn	App Total	Peds CW	Peds CCW	
4:15:00 PM	0	0	0	0	0	0	3	0	1	4	1	0	3	93	0	96	0	0	100
4:30:00 PM	0	0	0	0	0	0	1	0	0	1	0	1	2	86	0	88	0	0	89
4:45:00 PM	0	0	0	0	0	0	1	0	0	1	1	2	5	74	0	79	0	0	80
5:00:00 PM	0	0	0	0	0	0	1	0	1	2	3	1	2	69	0	71	0	0	73
Grand Total	0	0	0	0	0	0	6	0	2	8	5	4	12	322	0	334	0	0	342
% Approach	#####	#####	#####	0.0%	0.0%	0.0%	14.2%	0.0%	0.0%	0.0%	0.0%	0.0%	45.1%	41.7%	0.0%	0.0%	0.0%	0.0%	
% Total	0.0%	0.0%	0.0%	0.0%	0.0%	0.0%	1.8%	0.0%	0.6%	2.3%	0.0%	0.0%	3.5%	94.2%	0.0%	97.7%	0.0%	0.0%	
PHF	0.000	0.000	0.000	0.000	0.000	0.000	0.500	0.000	0.500	0.500	0.000	0.000	0.600	0.866	0.000	0.870	0.000	0.000	0.855
Lights	0	0	0	0	0	0	4	0	2	6	0	0	10	305	0	315	0	0	321
% Lights	0.0%	0.0%	0.0%	0.0%	0.0%	0.0%	66.7%	0.0%	100.0%	75.0%	0.0%	0.0%	83.3%	94.7%	0.0%	94.3%	0.0%	0.0%	93.9%
Trucks	0	0	0	0	0	0	0	0	0	0	0	0	0	0	0	0	0	0	0
% Trucks	0.0%	0.0%	0.0%	0.0%	0.0%	0.0%	0.0%	0.0%	0.0%	0.0%	0.0%	0.0%	0.0%	0.0%	0.0%	0.0%	0.0%	0.0%	0.0%
Buses	0	0	0	0	0	0	2	0	0	2	0	0	2	17	0	19	0	0	21
% Buses	0.0%	0.0%	0.0%	0.0%	0.0%	0.0%	33.3%	0.0%	0.0%	0.0%	0.0%	0.0%	16.7%	5.3%	0.0%	0.0%	0.0%	0.0%	6.1%
Pedestrians	0	0	0	0	0	0	0	0	0	0	3	4	0	0	0	0	0	0	0
% Pedestrians	0.0%	0.0%	0.0%	0.0%	0.0%	0.0%	0.0%	0.0%	0.0%	0.0%	60.0%	100.0%	0.0%	0.0%	0.0%	0.0%	0.0%	0.0%	0.0%
Bicycles on Crosswalk	0	0	0	0	0	0	0	0	0	0	2	0	0	0	0	0	0	0	0
% Bicycles on Crosswalk	0.0%	0.0%	0.0%	0.0%	0.0%	0.0%	0.0%	0.0%	0.0%	0.0%	40.0%	0.0%	0.0%	0.0%	0.0%	0.0%	0.0%	0.0%	0.0%

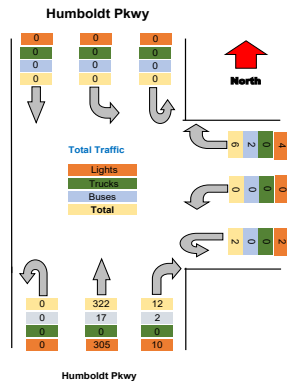

View from East

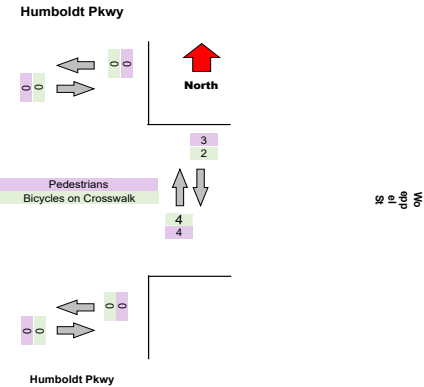

View from West

Intersection: Elm St Pine St
 Location: Kennett Square, PA
 Site: 01
 Survey Date: Wednesday, 04-28-2021
 GPS: 42.948550, -72.790034



Project	Labella
Project Code	Labella
Site Name	H
Legs and Movements	All Processed Legs & Movements
Bin Size	15 minutes
Survey Date	2021-10-28, Thursday
Location	H
Latitude and Longitude	42.911816, -78.843102

	Start	End	PHF
Forced Peak AM	2021/10/28 07:30:00	2021/10/28 08:30:00	0.865
Forced Peak PM	2021/10/28 16:30:00	2021/10/28 17:30:00	0.948
AM Peak	2021/10/28 07:30:00	2021/10/28 08:30:00	0.865
PM Peak	2021/10/28 16:15:00	2021/10/28 17:15:00	0.827

Turning Movement Data

Leg Direction	Humboldt Pkwy Southbound						Woepfel St Westbound						Humboldt Pkwy Northbound						Total	
	Thru	Left	U-Turn	App	Total	Peds CW/Peds CCW	Right	Left	U-Turn	App	Total	Peds CW/Peds CCW	Right	Thru	U-Turn	App	Total	Peds CW/Peds CCW		
Start Time																				
6:30:00 AM	0	0	0	0	0	0	1	0	0	1	0	0	0	27	0	27	0	0	0	28
6:45:00 AM	0	0	0	0	0	0	1	0	0	1	0	0	3	49	0	52	0	0	0	53
Hourly Total	0	0	0	0	0	0	2	0	0	2	0	0	3	76	0	79	0	0	0	81
7:00:00 AM	0	0	0	0	0	0	1	0	0	1	0	0	2	44	0	46	0	0	0	47
7:15:00 AM	0	0	0	0	0	0	1	0	0	1	4	1	1	39	0	45	0	0	0	46
7:30:00 AM	0	0	0	0	0	0	0	0	0	0	2	1	1	54	0	58	0	0	0	58
7:45:00 AM	0	0	0	0	0	0	1	0	0	1	0	0	2	73	0	75	0	0	0	76
Hourly Total	0	0	0	0	0	0	3	0	0	3	6	2	6	210	0	224	0	0	0	227
8:00:00 AM	0	0	0	0	0	0	2	0	0	2	0	0	0	76	0	76	0	0	0	78
8:15:00 AM	0	1	0	1	0	0	0	0	0	0	0	0	2	55	0	57	0	0	0	58
Hourly Total	0	1	0	1	0	0	2	0	0	2	0	0	2	131	0	133	0	0	0	136
4:00:00 PM	0	0	0	0	0	0	5	0	0	5	1	0	2	93	0	95	0	0	0	100
4:15:00 PM	0	0	0	0	0	0	1	0	0	1	0	0	6	100	0	106	0	0	0	107
4:30:00 PM	0	0	0	0	0	0	0	0	0	0	0	0	3	77	0	80	0	4	0	80
4:45:00 PM	0	0	0	0	0	0	3	0	0	3	1	0	4	74	0	78	0	0	0	81
Hourly Total	0	0	0	0	0	0	9	0	0	9	2	0	15	344	0	359	0	4	0	368
5:00:00 PM	0	0	0	0	1	0	4	0	0	4	1	0	3	79	0	82	0	0	0	86
5:15:00 PM	0	0	0	0	0	0	0	0	0	0	1	1	0	79	0	79	0	0	0	79
5:30:00 PM	0	0	0	0	0	0	2	0	0	2	1	0	1	76	0	77	0	0	0	79
5:45:00 PM	0	0	0	0	0	0	1	0	0	1	0	0	1	69	0	70	0	0	0	71
Hourly Total	0	0	0	0	1	0	7	0	0	7	3	1	5	303	0	308	0	0	0	315
Grand Total	0	1	0	1	1	0	23	0	0	23	11	3	31	1064	0	1103	0	4	0	1127
% Approach	0.0%	100.0%	0.0%	0.0%	0.0%	0.0%	100.0%	0.0%	0.0%	0.0%	0.0%	0.0%	2.8%	96.5%	0.0%	0.0%	0.0%	0.0%	0.0%	0.0%
% Total	0.0%	0.1%	0.0%	0.1%	0.0%	0.0%	2.0%	0.0%	0.0%	2.0%	0.0%	0.0%	2.8%	94.4%	0.0%	97.9%	0.0%	0.0%	0.0%	0.0%
Lights	0	1	0	1	0	0	20	0	0	20	0	0	24	1022	0	1046	0	0	0	1067
% Lights	0.0%	100.0%	0.0%	100.0%	0.0%	0.0%	87.0%	0.0%	0.0%	87.0%	0.0%	0.0%	77.4%	96.1%	0.0%	94.8%	0.0%	0.0%	0.0%	94.7%
Trucks	0	0	0	0	0	0	0	0	0	0	0	0	0	0	0	0	0	0	0	0
% Trucks	0.0%	0.0%	0.0%	0.0%	0.0%	0.0%	0.0%	0.0%	0.0%	0.0%	0.0%	0.0%	0.0%	0.0%	0.0%	0.0%	0.0%	0.0%	0.0%	0.0%
Buses	0	0	0	0	0	0	3	0	0	3	0	0	7	41	0	48	0	0	0	51
% Buses	0.0%	0.0%	0.0%	0.0%	0.0%	0.0%	0.0%	0.0%	0.0%	0.0%	0.0%	0.0%	22.6%	3.9%	0.0%	0.0%	0.0%	0.0%	0.0%	4.5%
Pedestrians	0	0	0	0	1	0	0	0	0	0	11	2	0	0	0	0	0	4	0	0
% Pedestrians	0.0%	0.0%	0.0%	0.0%	100.0%	0.0%	0.0%	0.0%	0.0%	0.0%	100.0%	66.7%	0.0%	0.0%	0.0%	0.0%	0.0%	100.0%	0.0%	0.0%
Bicycles on Crosswalk	0	0	0	0	0	0	0	0	0	0	0	1	0	0	0	0	0	0	0	0
% Bicycles on Crosswalk	0.0%	0.0%	0.0%	0.0%	0.0%	0.0%	0.0%	0.0%	0.0%	0.0%	0.0%	33.3%	0.0%	0.0%	0.0%	0.0%	0.0%	0.0%	0.0%	0.0%

Turning Movement Data Plot

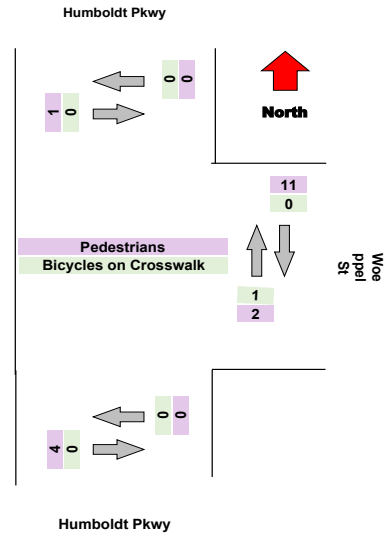
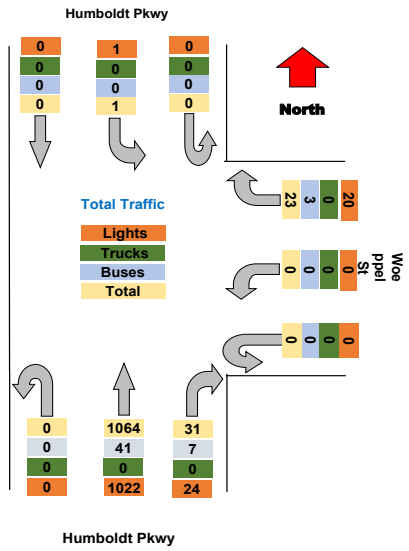

Turning Movement Peak Hour Data (AM)

7:30:00 AM

Leg	Humboldt Pkwy						Woepfel St						Humboldt Pkwy						Total
	Southbound						Westbound						Northbound						
Direction	Thru	Left	U-Turn	App	Total	Peds CW/Peds CCW	Right	Left	U-Turn	App	Total	Peds CW/Peds CCW	Right	Thru	U-Turn	App	Total	Peds CW/Peds CCW	
7:30:00 AM	0	0	0	0	0	0	0	0	0	0	2	1	1	54	0	0	58	0	0
7:45:00 AM	0	0	0	0	0	0	1	0	0	1	0	0	2	73	0	0	75	0	0
8:00:00 AM	0	0	0	0	0	0	2	0	0	2	0	0	0	76	0	0	76	0	0
8:15:00 AM	0	1	0	1	0	0	0	0	0	0	0	0	2	55	0	0	57	0	0
Grand Total	0	1	0	1	0	0	3	0	0	3	0	1	5	258	0	0	266	0	0
% Approach	0.0%	100.0%	0.0%	0.0%	0.0%	0.0%	14.2%	0.0%	0.0%	0.0%	0.0%	0.0%	45.1%	14.7%	0.0%	0.0%	0.0%	0.0%	0.0%
% Total	0.0%	0.4%	0.0%	0.4%	0.0%	0.0%	1.1%	0.0%	0.0%	1.1%	0.0%	0.0%	1.9%	95.6%	0.0%	0.0%	98.5%	0.0%	0.0%
PHF	0.000	0.250	0.000	0.250	0.000	0.000	0.375	0.000	0.000	0.375	0.000	0.000	0.625	0.849	0.000	0.000	0.875	0.000	0.000
Lights	0	1	0	1	0	0	3	0	0	3	0	0	2	244	0	0	246	0	0
% Lights	0.0%	100.0%	0.0%	100.0%	0.0%	0.0%	100.0%	0.0%	0.0%	100.0%	0.0%	0.0%	40.0%	94.6%	0.0%	0.0%	92.5%	0.0%	0.0%
Trucks	0	0	0	0	0	0	0	0	0	0	0	0	0	0	0	0	0	0	0
% Trucks	0.0%	0.0%	0.0%	0.0%	0.0%	0.0%	0.0%	0.0%	0.0%	0.0%	0.0%	0.0%	0.0%	0.0%	0.0%	0.0%	0.0%	0.0%	0.0%
Buses	0	0	0	0	0	0	0	0	0	0	0	0	3	14	0	0	17	0	0
% Buses	0.0%	0.0%	0.0%	0.0%	0.0%	0.0%	0.0%	0.0%	0.0%	0.0%	0.0%	0.0%	60.0%	5.4%	0.0%	0.0%	0.0%	0.0%	0.0%
Pedestrians	0	0	0	0	0	0	0	0	0	0	2	1	0	0	0	0	0	0	0
% Pedestrians	0.0%	0.0%	0.0%	0.0%	0.0%	0.0%	0.0%	0.0%	0.0%	0.0%	100.0%	100.0%	0.0%	0.0%	0.0%	0.0%	0.0%	0.0%	0.0%
Bicycles on Crosswalk	0	0	0	0	0	0	0	0	0	0	0	0	0	0	0	0	0	0	0
% Bicycles on Crosswalk	0.0%	0.0%	0.0%	0.0%	0.0%	0.0%	0.0%	0.0%	0.0%	0.0%	0.0%	0.0%	0.0%	0.0%	0.0%	0.0%	0.0%	0.0%	0.0%

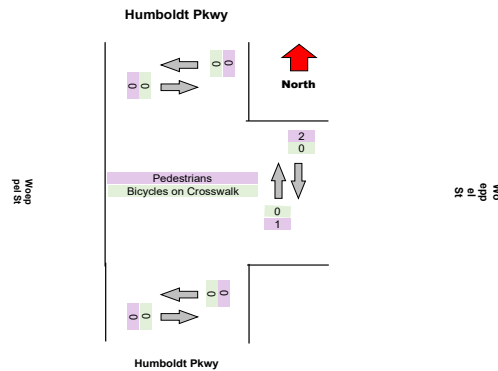
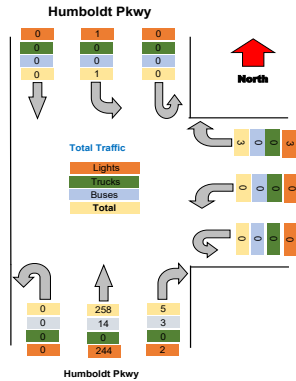

Turning Movement Peak Hour Data (PM)
 4:15:00 PM

Leg Direction	Humboldt Pkwy Southbound						Woepfel St Westbound						Humboldt Pkwy Northbound						Total							
	Thru	Left	U-Turn	App	Total	Peds	CW	Peds	CCW	Right	Left	U-Turn	App	Total	Peds	CW	Peds	CCW								
4:15:00 PM	0	0	0	0	0	0	0	0	0	1	0	0	1	0	0	0	0	0	0	6	100	0	106	0	0	107
4:30:00 PM	0	0	0	0	0	0	0	0	0	0	0	0	0	0	0	0	0	0	0	3	77	0	80	0	4	80
4:45:00 PM	0	0	0	0	0	0	0	0	0	3	0	0	3	1	0	0	0	0	0	4	74	0	78	0	0	81
5:00:00 PM	0	0	0	0	0	1	0	0	0	4	0	0	4	1	0	0	0	0	0	3	79	0	82	0	0	86
Grand Total	0	0	0	0	0	1	0	0	0	8	0	0	8	2	0	0	0	0	0	16	330	0	346	0	4	354
% Approach	#####	#DIV/0!	#####	0.0%	0.0%	0.0%	0.0%	14.2%	0.0%	0.0%	0.0%	0.0%	0.0%	0.0%	0.0%	0.0%	0.0%	0.0%	45.1%	41.7%	0.0%	0.0%	0.0%	0.0%		
% Total	0.0%	0.0%	0.0%	0.0%	0.0%	0.0%	0.0%	2.3%	0.0%	0.0%	0.0%	2.3%	0.0%	0.0%	0.0%	0.0%	0.0%	0.0%	4.5%	93.2%	0.0%	97.7%	0.0%	0.0%		
PHF	0.000	0.000	0.000	0.000	0.000	0.000	0.000	0.500	0.000	0.000	0.000	0.500	0.000	0.000	0.000	0.000	0.000	0.000	0.667	0.825	0.000	0.816	0.000	0.000		
Lights	0	0	0	0	0	0	0	6	0	0	0	6	0	0	0	0	0	0	14	317	0	331	0	0	337	
% Lights	0.0%	0.0%	0.0%	0.0%	0.0%	0.0%	0.0%	75.0%	0.0%	0.0%	0.0%	75.0%	0.0%	0.0%	0.0%	0.0%	0.0%	0.0%	87.5%	96.1%	0.0%	95.7%	0.0%	0.0%		
Trucks	0	0	0	0	0	0	0	0	0	0	0	0	0	0	0	0	0	0	0	0	0	0	0	0	0	
% Trucks	0.0%	0.0%	0.0%	0.0%	0.0%	0.0%	0.0%	0.0%	0.0%	0.0%	0.0%	0.0%	0.0%	0.0%	0.0%	0.0%	0.0%	0.0%	0.0%	0.0%	0.0%	0.0%	0.0%	0.0%		
Buses	0	0	0	0	0	0	0	2	0	0	0	2	0	0	0	0	0	0	2	12	0	14	0	0	16	
% Buses	0.0%	0.0%	0.0%	0.0%	0.0%	0.0%	0.0%	25.0%	0.0%	0.0%	0.0%	25.0%	0.0%	0.0%	0.0%	0.0%	0.0%	0.0%	12.5%	3.6%	0.0%	0.0%	0.0%	0.0%		
Pedestrians	0	0	0	0	1	0	0	0	0	0	0	0	2	0	0	0	0	4	0	0	0	0	0	4	0	
% Pedestrians	0.0%	0.0%	0.0%	0.0%	100.0%	0.0%	0.0%	0.0%	0.0%	0.0%	0.0%	0.0%	100.0%	0.0%	0.0%	0.0%	0.0%	100.0%	0.0%	0.0%	0.0%	0.0%	100.0%	0.0%		
Bicycles on Crosswalk	0	0	0	0	0	0	0	0	0	0	0	0	0	0	0	0	0	0	0	0	0	0	0	0	0	
% Bicycles on Crosswalk	0.0%	0.0%	0.0%	0.0%	0.0%	0.0%	0.0%	0.0%	0.0%	0.0%	0.0%	0.0%	0.0%	0.0%	0.0%	0.0%	0.0%	0.0%	0.0%	0.0%	0.0%	0.0%	0.0%	0.0%		

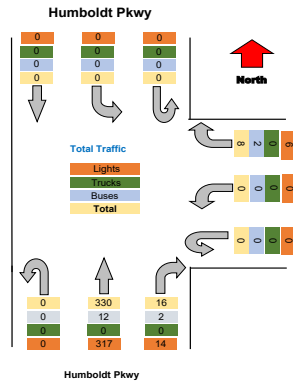

Woepfel St

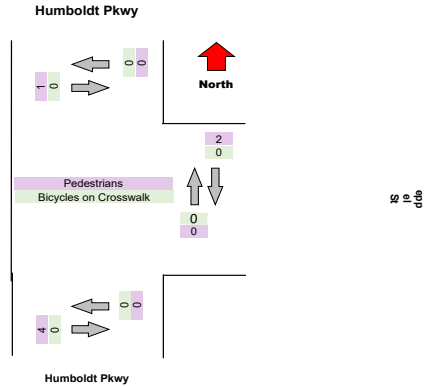

Woepfel St

Intersection: Elm St Pine St
 Location: Kennett Square, PA
 Site: 01
 Survey Date: Wednesday, 04-28-2021
 GPS: 42.948550, -72.790034



Project	Labella
Project Code	Labella
Site Name	I
Legs and Movements	All Processed Legs & Movements
Bin Size	15 minutes
Survey Date	2021-10-26, Tuesday
Location	I
Latitude and Longitude	42.913815, -78.843121

	Start	End	PHF
Forced Peak AM	2021/10/26 07:30:00	2021/10/26 08:30:00	0.916
Forced Peak PM	2021/10/26 16:30:00	2021/10/26 17:30:00	0.942
AM Peak	2021/10/26 07:30:00	2021/10/26 08:30:00	0.916
PM Peak	2021/10/26 16:30:00	2021/10/26 17:30:00	0.942

Turning Movement Data

Leg Direction	Humboldt Pkwy Southbound						Woodlawn Ave Westbound						Humboldt Pkwy Northbound						Total
	Thru	Left	U-Turn	App Total	Peds CW	Peds CCW	Right	Left	U-Turn	App Total	Peds CW	Peds CCW	Right	Thru	U-Turn	App Total	Peds CW	Peds CCW	
Start Time																			
6:30:00 AM	0	0	0	0	0	0	4	0	0	4	0	0	1	30	0	31	0	0	35
6:45:00 AM	0	0	0	0	0	0	0	0	0	0	0	2	0	40	0	42	0	0	42
Hourly Total	0	0	0	0	0	0	4	0	0	4	0	2	1	70	0	73	0	0	77
7:00:00 AM	0	0	0	0	0	0	1	0	0	1	0	0	2	54	0	56	0	0	57
7:15:00 AM	0	0	0	0	0	0	4	0	0	4	1	0	2	38	0	41	0	0	45
7:30:00 AM	0	0	0	0	0	0	3	0	0	3	0	0	2	54	0	56	0	0	59
7:45:00 AM	0	0	0	0	0	0	1	0	0	1	0	0	0	70	0	70	0	0	71
Hourly Total	0	0	0	0	0	0	9	0	0	9	1	0	6	216	0	223	0	0	232
8:00:00 AM	0	0	0	0	0	0	2	0	0	2	0	0	2	63	0	65	0	0	67
8:15:00 AM	0	0	0	0	0	0	4	0	0	4	0	0	4	66	0	70	0	0	74
Hourly Total	0	0	0	0	0	0	6	0	0	6	0	0	6	129	0	135	0	0	141
4:00:00 PM	0	0	0	0	0	0	2	0	0	2	0	0	4	87	0	91	0	0	93
4:15:00 PM	0	0	0	0	0	0	2	0	0	2	0	0	3	72	0	75	0	0	77
4:30:00 PM	0	0	0	0	0	0	4	0	0	4	1	0	1	66	0	67	0	0	71
4:45:00 PM	0	0	0	0	0	0	5	0	0	5	0	0	2	75	0	77	0	0	82
Hourly Total	0	0	0	0	0	0	13	0	0	13	1	0	10	300	0	310	0	0	323
5:00:00 PM	0	0	0	0	0	0	3	0	0	3	0	0	3	69	0	72	0	0	75
5:15:00 PM	0	0	0	0	0	0	8	0	0	8	0	0	1	72	0	73	0	0	81
5:30:00 PM	0	0	0	0	0	0	2	0	0	2	0	2	5	67	0	72	0	0	74
5:45:00 PM	0	0	0	0	0	0	5	0	0	5	0	0	3	51	0	54	0	0	59
Hourly Total	0	0	0	0	0	0	18	0	0	18	0	2	12	259	0	271	0	0	289
Grand Total	0	0	0	0	0	0	50	0	0	50	2	4	35	974	0	1012	0	0	1062
% Approach	0.0%	0.0%	0.0%	0.0%	0.0%	0.0%	100.0%	0.0%	0.0%	0.0%	0.0%	0.0%	3.5%	96.2%	0.0%	0.0%	0.0%	0.0%	0.0%
% Total	0.0%	0.0%	0.0%	0.0%	0.0%	0.0%	4.7%	0.0%	0.0%	4.7%	0.0%	0.0%	3.3%	91.7%	0.0%	95.3%	0.0%	0.0%	0.0%
Lights	0	0	0	0	0	0	40	0	0	40	0	0	34	929	0	963	0	0	1003
% Lights	0.0%	0.0%	0.0%	0.0%	0.0%	0.0%	80.0%	0.0%	0.0%	80.0%	0.0%	0.0%	97.1%	95.4%	0.0%	95.2%	0.0%	0.0%	94.4%
Trucks	0	0	0	0	0	0	0	0	0	0	0	0	0	0	0	0	0	0	0
% Trucks	0.0%	0.0%	0.0%	0.0%	0.0%	0.0%	0.0%	0.0%	0.0%	0.0%	0.0%	0.0%	0.0%	0.0%	0.0%	0.0%	0.0%	0.0%	0.0%
Buses	0	0	0	0	0	0	10	0	0	10	0	0	1	45	0	46	0	0	56
% Buses	0.0%	0.0%	0.0%	0.0%	0.0%	0.0%	0.0%	0.0%	0.0%	0.0%	0.0%	0.0%	2.9%	4.6%	0.0%	0.0%	0.0%	0.0%	5.3%
Pedestrians	0	0	0	0	0	0	0	0	0	0	2	4	0	0	0	0	0	0	0
% Pedestrians	0.0%	0.0%	0.0%	0.0%	0.0%	0.0%	0.0%	0.0%	0.0%	0.0%	100.0%	100.0%	0.0%	0.0%	0.0%	0.0%	0.0%	0.0%	0.0%
Bicycles on Crosswalk	0	0	0	0	0	0	0	0	0	0	0	0	0	0	0	0	0	0	0
% Bicycles on Crosswalk	0.0%	0.0%	0.0%	0.0%	0.0%	0.0%	0.0%	0.0%	0.0%	0.0%	0.0%	0.0%	0.0%	0.0%	0.0%	0.0%	0.0%	0.0%	0.0%

Turning Movement Data Plot

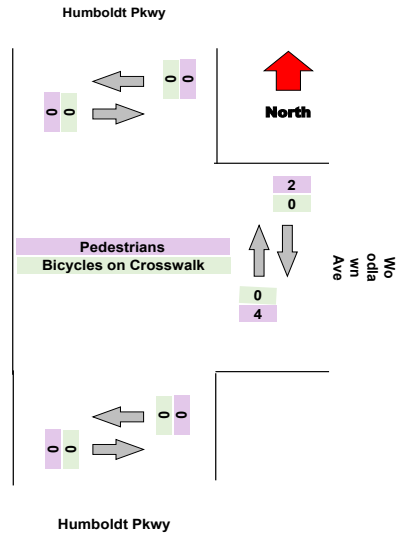
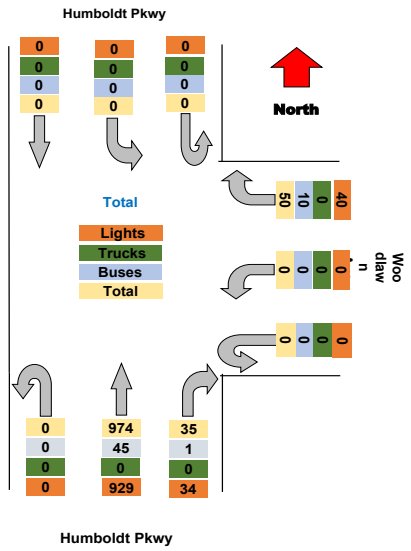

Turning Movement Peak Hour Data (AM)
 7:30:00 AM

Leg	Humboldt Pkwy						Woodlawn Ave						Humboldt Pkwy						Total									
	Southbound						Westbound						Northbound															
Direction	Thru	Left	U-Turn	App	Total	Peds	CW	Peds	CCW	Right	Left	U-Turn	App	Total	Peds	CW	Peds	CCW	Right	Thru	U-Turn	App	Total	Peds	CW	Peds	CCW	
7:30:00 AM	0	0	0	0	0	0	0	0	0	3	0	0	3	0	0	0	0	0	0	2	54	0	56	0	0	0	0	0
7:45:00 AM	0	0	0	0	0	0	0	0	0	1	0	0	1	0	0	0	0	0	0	0	70	0	70	0	0	0	0	0
8:00:00 AM	0	0	0	0	0	0	0	0	0	2	0	0	2	0	0	0	0	0	0	2	63	0	65	0	0	0	0	0
8:15:00 AM	0	0	0	0	0	0	0	0	0	4	0	0	4	0	0	0	0	0	0	4	66	0	70	0	0	0	0	0
Grand Total	0	0	0	0	0	0	0	0	0	10	0	0	10	0	0	0	0	0	8	253	0	261	0	0	0	0	0	
% Approach	#####	#####	#####	0.0%	0.0%	0.0%	0.0%	0.0%	0.0%	14.2%	0.0%	0.0%	0.0%	0.0%	0.0%	0.0%	0.0%	0.0%	45.1%	41.7%	0.0%	0.0%	0.0%	0.0%	0.0%	0.0%	0.0%	
% Total	0.0%	0.0%	0.0%	0.0%	0.0%	0.0%	0.0%	0.0%	0.0%	3.7%	0.0%	0.0%	3.7%	0.0%	0.0%	0.0%	0.0%	0.0%	3.0%	93.4%	0.0%	96.3%	0.0%	0.0%	0.0%	0.0%	0.0%	
PHF	0.000	0.000	0.000	0.000	0.000	0.000	0.000	0.000	0.000	0.625	0.000	0.000	0.625	0.000	0.000	0.000	0.000	0.000	0.500	0.904	0.000	0.932	0.000	0.000	0.000	0.000	0.000	
Lights	0	0	0	0	0	0	0	0	0	9	0	0	9	0	0	0	0	0	7	240	0	247	0	0	0	0	0	
% Lights	0.0%	0.0%	0.0%	0.0%	0.0%	0.0%	0.0%	0.0%	0.0%	90.0%	0.0%	0.0%	90.0%	0.0%	0.0%	0.0%	0.0%	0.0%	87.5%	94.9%	0.0%	94.6%	0.0%	0.0%	0.0%	0.0%	0.0%	
Trucks	0	0	0	0	0	0	0	0	0	0	0	0	0	0	0	0	0	0	0	0	0	0	0	0	0	0	0	
% Trucks	0.0%	0.0%	0.0%	0.0%	0.0%	0.0%	0.0%	0.0%	0.0%	0.0%	0.0%	0.0%	0.0%	0.0%	0.0%	0.0%	0.0%	0.0%	0.0%	0.0%	0.0%	0.0%	0.0%	0.0%	0.0%	0.0%	0.0%	
Buses	0	0	0	0	0	0	0	0	0	1	0	0	1	0	0	0	0	0	1	13	0	14	0	0	0	0	0	
% Buses	0.0%	0.0%	0.0%	0.0%	0.0%	0.0%	0.0%	0.0%	0.0%	10.0%	0.0%	0.0%	10.0%	0.0%	0.0%	0.0%	0.0%	0.0%	12.5%	5.1%	0.0%	0.0%	0.0%	0.0%	0.0%	0.0%	0.0%	
Pedestrians	0	0	0	0	0	0	0	0	0	0	0	0	0	0	0	0	0	0	0	0	0	0	0	0	0	0	0	
% Pedestrians	0.0%	0.0%	0.0%	0.0%	0.0%	0.0%	0.0%	0.0%	0.0%	0.0%	0.0%	0.0%	0.0%	0.0%	0.0%	0.0%	0.0%	0.0%	0.0%	0.0%	0.0%	0.0%	0.0%	0.0%	0.0%	0.0%	0.0%	
Bicycles on Crosswalk	0	0	0	0	0	0	0	0	0	0	0	0	0	0	0	0	0	0	0	0	0	0	0	0	0	0	0	
% Bicycles on Crosswalk	0.0%	0.0%	0.0%	0.0%	0.0%	0.0%	0.0%	0.0%	0.0%	0.0%	0.0%	0.0%	0.0%	0.0%	0.0%	0.0%	0.0%	0.0%	0.0%	0.0%	0.0%	0.0%	0.0%	0.0%	0.0%	0.0%	0.0%	

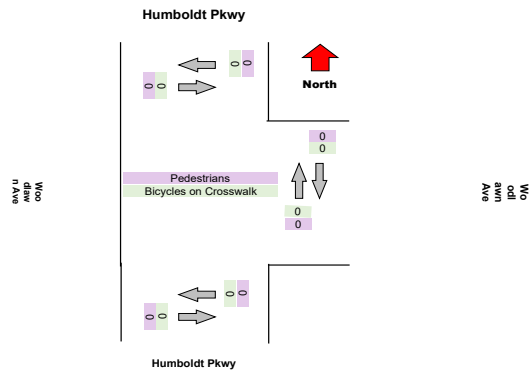
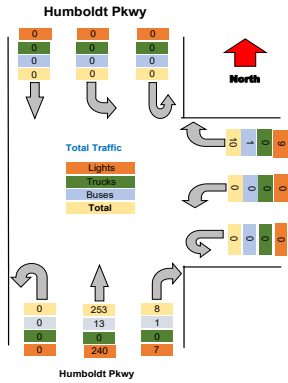

Turning Movement Peak Hour Data (PM)
 4:30:00 PM

Leg	Humboldt Pkwy						Woodlawn Ave						Humboldt Pkwy						Total
	Southbound						Westbound						Northbound						
Direction	Thru	Left	U-Turn	App Total	Peds CW	Peds CCW	Right	Left	U-Turn	App Total	Peds CW	Peds CCW	Right	Thru	U-Turn	App Total	Peds CW	Peds CCW	
4:30:00 PM	0	0	0	0	0	0	4	0	0	4	1	0	1	66	0	67	0	0	71
4:45:00 PM	0	0	0	0	0	0	5	0	0	5	0	0	2	75	0	77	0	0	82
5:00:00 PM	0	0	0	0	0	0	3	0	0	3	0	0	3	69	0	72	0	0	75
5:15:00 PM	0	0	0	0	0	0	8	0	0	8	0	0	1	72	0	73	0	0	81
Grand Total	0	0	0	0	0	0	20	0	0	20	1	0	7	282	0	289	0	0	309
% Approach	#####	#####	#####	0.0%	0.0%	0.0%	14.2%	0.0%	0.0%	0.0%	0.0%	0.0%	45.1%	41.7%	0.0%	0.0%	0.0%	0.0%	
% Total	0.0%	0.0%	0.0%	0.0%	0.0%	0.0%	6.5%	0.0%	0.0%	6.5%	0.0%	0.0%	2.3%	91.3%	0.0%	93.5%	0.0%	0.0%	
PHF	0.000	0.000	0.000	0.000	0.000	0.000	0.625	0.000	0.000	0.625	0.000	0.000	0.583	0.940	0.000	0.938	0.000	0.000	0.942
Lights	0	0	0	0	0	0	17	0	0	17	0	0	7	274	0	281	0	0	288
% Lights	0.0%	0.0%	0.0%	0.0%	0.0%	0.0%	85.0%	0.0%	0.0%	85.0%	0.0%	0.0%	100.0%	97.2%	0.0%	97.2%	0.0%	0.0%	96.4%
Trucks	0	0	0	0	0	0	0	0	0	0	0	0	0	0	0	0	0	0	0
% Trucks	0.0%	0.0%	0.0%	0.0%	0.0%	0.0%	0.0%	0.0%	0.0%	0.0%	0.0%	0.0%	0.0%	0.0%	0.0%	0.0%	0.0%	0.0%	0.0%
Buses	0	0	0	0	0	0	3	0	0	3	0	0	0	8	0	8	0	0	11
% Buses	0.0%	0.0%	0.0%	0.0%	0.0%	0.0%	15.0%	0.0%	0.0%	0.0%	0.0%	0.0%	0.0%	2.8%	0.0%	0.0%	0.0%	0.0%	3.6%
Pedestrians	0	0	0	0	0	0	0	0	0	0	1	0	0	0	0	0	0	0	0
% Pedestrians	0.0%	0.0%	0.0%	0.0%	0.0%	0.0%	0.0%	0.0%	0.0%	0.0%	100.0%	0.0%	0.0%	0.0%	0.0%	0.0%	0.0%	0.0%	0.0%
Bicycles on Crosswalk	0	0	0	0	0	0	0	0	0	0	0	0	0	0	0	0	0	0	0
% Bicycles on Crosswalk	0.0%	0.0%	0.0%	0.0%	0.0%	0.0%	0.0%	0.0%	0.0%	0.0%	0.0%	0.0%	0.0%	0.0%	0.0%	0.0%	0.0%	0.0%	0.0%

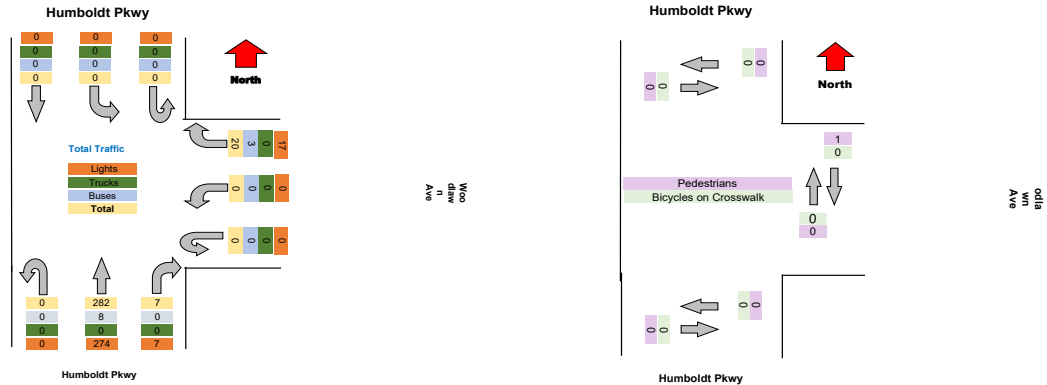

Turning Movement Data Plot

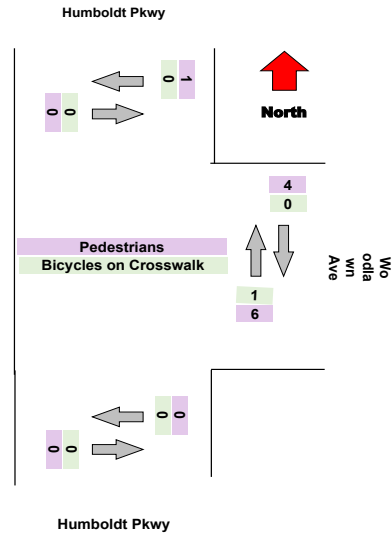
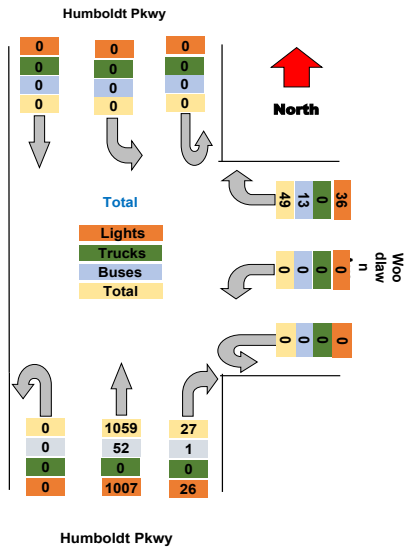

Turning Movement Peak Hour Data (AM)
 7:30:00 AM

Leg Direction	Humboldt Pkwy Southbound						Woodlawn Ave Westbound						Humboldt Pkwy Northbound						Total
	Thru	Left	U-Turn	App Total	Peds CW	Peds CCW	Right	Left	U-Turn	App Total	Peds CW	Peds CCW	Right	Thru	U-Turn	App Total	Peds CW	Peds CCW	
7:30:00 AM	0	0	0	0	0	0	6	0	0	6	0	1	1	55	0	57	0	0	63
7:45:00 AM	0	0	0	0	0	0	0	0	0	0	0	1	0	74	0	74	0	0	74
8:00:00 AM	0	0	0	0	0	0	2	0	0	2	0	1	5	75	0	81	0	0	83
8:15:00 AM	0	0	0	0	0	0	3	0	0	3	0	0	2	44	0	46	0	0	49
Grand Total	0	0	0	0	0	0	11	0	0	11	0	2	8	248	0	258	0	0	269
% Approach	#####	#####	#####	0.0%	0.0%	0.0%	14.2%	0.0%	0.0%	0.0%	0.0%	0.0%	45.1%	41.7%	0.0%	0.0%	0.0%	0.0%	
% Total	0.0%	0.0%	0.0%	0.0%	0.0%	0.0%	4.1%	0.0%	0.0%	4.1%	0.0%	0.0%	3.0%	92.2%	0.0%	95.9%	0.0%	0.0%	
PHF	0.000	0.000	0.000	0.000	0.000	0.000	0.458	0.000	0.000	0.458	0.000	0.000	0.400	0.827	0.000	0.796	0.000	0.000	0.810
Lights	0	0	0	0	0	0	9	0	0	9	0	0	7	235	0	242	0	0	251
% Lights	0.0%	0.0%	0.0%	0.0%	0.0%	0.0%	81.8%	0.0%	0.0%	81.8%	0.0%	0.0%	87.5%	94.8%	0.0%	93.8%	0.0%	0.0%	93.3%
Trucks	0	0	0	0	0	0	0	0	0	0	0	0	0	0	0	0	0	0	0
% Trucks	0.0%	0.0%	0.0%	0.0%	0.0%	0.0%	0.0%	0.0%	0.0%	0.0%	0.0%	0.0%	0.0%	0.0%	0.0%	0.0%	0.0%	0.0%	0.0%
Buses	0	0	0	0	0	0	2	0	0	2	0	0	1	13	0	14	0	0	16
% Buses	0.0%	0.0%	0.0%	0.0%	0.0%	0.0%	18.2%	0.0%	0.0%	0.0%	0.0%	0.0%	12.5%	5.2%	0.0%	0.0%	0.0%	0.0%	5.9%
Pedestrians	0	0	0	0	0	0	0	0	0	0	2	0	0	0	0	0	0	0	0
% Pedestrians	0.0%	0.0%	0.0%	0.0%	0.0%	0.0%	0.0%	0.0%	0.0%	0.0%	100.0%	0.0%	0.0%	0.0%	0.0%	0.0%	0.0%	0.0%	0.0%
Bicycles on Crosswalk	0	0	0	0	0	0	0	0	0	0	0	0	0	0	0	0	0	0	0
% Bicycles on Crosswalk	0.0%	0.0%	0.0%	0.0%	0.0%	0.0%	0.0%	0.0%	0.0%	0.0%	0.0%	0.0%	0.0%	0.0%	0.0%	0.0%	0.0%	0.0%	0.0%

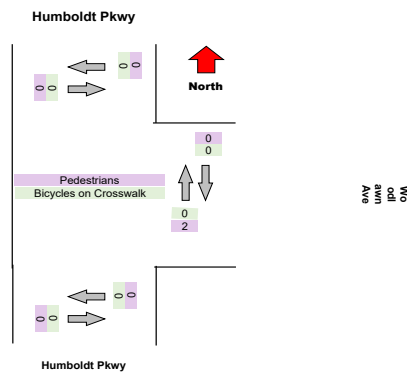
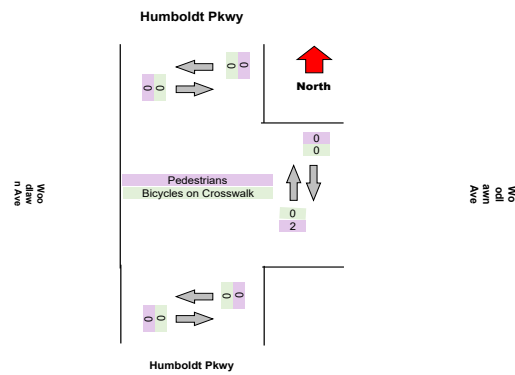
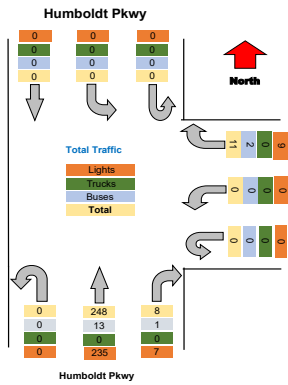

Turning Movement Peak Hour Data (PM)
 4:30:00 PM

Leg Direction	Humboldt Pkwy						Woodlawn Ave						Humboldt Pkwy						Total
	Southbound						Westbound						Northbound						
	Thru	Left	U-Turn	App Total	Peds CW	Peds CCW	Right	Left	U-Turn	App Total	Peds CW	Peds CCW	Right	Thru	U-Turn	App Total	Peds CW	Peds CCW	
4:30:00 PM	0	0	0	0	0	0	4	0	0	4	1	0	2	85	0	87	0	0	91
4:45:00 PM	0	0	0	0	0	0	5	0	0	5	2	0	2	68	0	70	0	0	75
5:00:00 PM	0	0	0	0	0	1	7	0	0	7	0	2	1	74	0	75	0	0	82
5:15:00 PM	0	0	0	0	0	0	3	0	0	3	0	0	4	87	0	91	0	0	94
Grand Total	0	0	0	0	0	1	19	0	0	19	3	2	9	314	0	323	0	0	342
% Approach	#####	#####	#####	0.0%	0.0%	0.0%	14.2%	0.0%	0.0%	0.0%	0.0%	0.0%	45.1%	41.7%	0.0%	0.0%	0.0%	0.0%	
% Total	0.0%	0.0%	0.0%	0.0%	0.0%	0.0%	5.6%	0.0%	0.0%	5.6%	0.0%	0.0%	2.6%	91.8%	0.0%	94.4%	0.0%	0.0%	
PHF	0.000	0.000	0.000	0.000	0.000	0.000	0.679	0.000	0.000	0.679	0.000	0.000	0.563	0.902	0.000	0.887	0.000	0.000	0.910
Lights	0	0	0	0	0	0	15	0	0	15	0	0	9	302	0	311	0	0	326
% Lights	0.0%	0.0%	0.0%	0.0%	0.0%	0.0%	78.9%	0.0%	0.0%	78.9%	0.0%	0.0%	#####	96.2%	0.0%	96.3%	0.0%	0.0%	95.3%
Trucks	0	0	0	0	0	0	0	0	0	0	0	0	0	0	0	0	0	0	0
% Trucks	0.0%	0.0%	0.0%	0.0%	0.0%	0.0%	0.0%	0.0%	0.0%	0.0%	0.0%	0.0%	0.0%	0.0%	0.0%	0.0%	0.0%	0.0%	0.0%
Buses	0	0	0	0	0	0	4	0	0	4	0	0	0	12	0	12	0	0	16
% Buses	0.0%	0.0%	0.0%	0.0%	0.0%	0.0%	21.1%	0.0%	0.0%	0.0%	0.0%	0.0%	0.0%	3.8%	0.0%	0.0%	0.0%	0.0%	4.7%
Pedestrians	0	0	0	0	0	1	0	0	0	0	3	2	0	0	0	0	0	0	0
% Pedestrians	0.0%	0.0%	0.0%	0.0%	0.0%	100.0%	0.0%	0.0%	0.0%	0.0%	100.0%	100.0%	0.0%	0.0%	0.0%	0.0%	0.0%	0.0%	0.0%
Bicycles on Crosswalk	0	0	0	0	0	0	0	0	0	0	0	0	0	0	0	0	0	0	0
% Bicycles on Crosswalk	0.0%	0.0%	0.0%	0.0%	0.0%	0.0%	0.0%	0.0%	0.0%	0.0%	0.0%	0.0%	0.0%	0.0%	0.0%	0.0%	0.0%	0.0%	0.0%

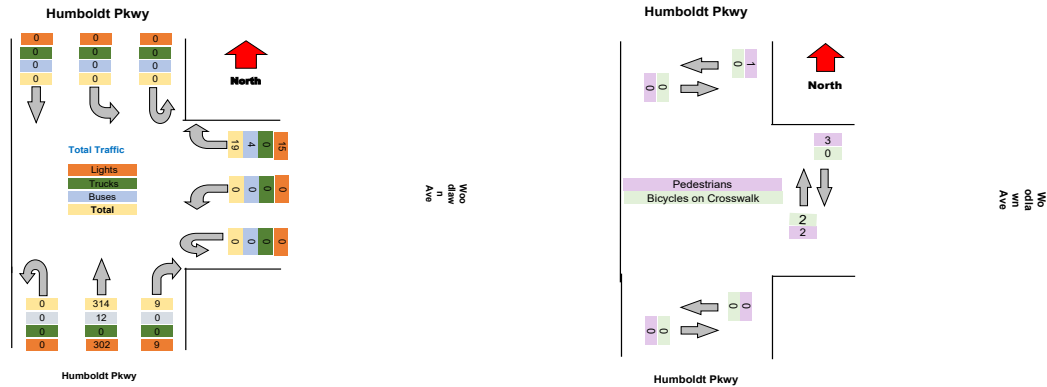

Turning Movement Data Plot

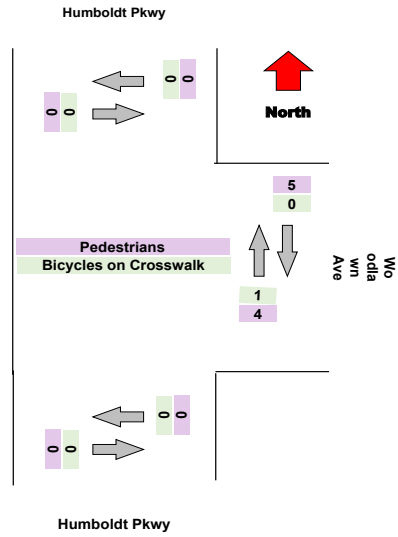
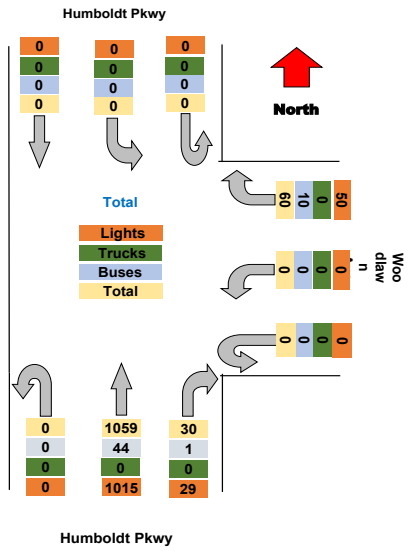

Turning Movement Peak Hour Data (AM)
 7:30:00 AM

Leg Direction	Humboldt Pkwy						Woodlawn Ave						Humboldt Pkwy						Total
	Southbound						Westbound						Northbound						
Start Time	Thru	Left	U-Turn	App Total	Peds CW	Peds CCW	Right	Left	U-Turn	App Total	Peds CW	Peds CCW	Right	Thru	U-Turn	App Total	Peds CW	Peds CCW	
7:30:00 AM	0	0	0	0	0	0	3	0	0	3	0	1	1	52	0	54	0	0	
7:45:00 AM	0	0	0	0	0	0	5	0	0	5	0	0	1	74	0	75	0	0	
8:00:00 AM	0	0	0	0	0	0	1	0	0	1	0	0	3	76	0	79	0	0	
8:15:00 AM	0	0	0	0	0	0	2	0	0	2	0	0	3	47	0	50	0	0	
Grand Total	0	0	0	0	0	0	11	0	0	11	0	1	8	249	0	258	0	0	
% Approach	#####	#####	#####	0.0%	0.0%	0.0%	14.2%	0.0%	0.0%	0.0%	0.0%	0.0%	45.1%	41.7%	0.0%	0.0%	0.0%	0.0%	
% Total	0.0%	0.0%	0.0%	0.0%	0.0%	0.0%	4.1%	0.0%	0.0%	4.1%	0.0%	0.0%	3.0%	92.6%	0.0%	95.9%	0.0%	0.0%	
PHF	0.000	0.000	0.000	0.000	0.000	0.000	0.550	0.000	0.000	0.550	0.000	0.000	0.667	0.819	0.000	0.816	0.000	0.000	
Lights	0	0	0	0	0	0	10	0	0	10	0	0	7	235	0	242	0	0	
% Lights	0.0%	0.0%	0.0%	0.0%	0.0%	0.0%	90.9%	0.0%	0.0%	90.9%	0.0%	0.0%	87.5%	94.4%	0.0%	93.8%	0.0%	0.0%	
Trucks	0	0	0	0	0	0	0	0	0	0	0	0	0	0	0	0	0	0	
% Trucks	0.0%	0.0%	0.0%	0.0%	0.0%	0.0%	0.0%	0.0%	0.0%	0.0%	0.0%	0.0%	0.0%	0.0%	0.0%	0.0%	0.0%	0.0%	
Buses	0	0	0	0	0	0	1	0	0	1	0	0	1	14	0	15	0	0	
% Buses	0.0%	0.0%	0.0%	0.0%	0.0%	0.0%	9.1%	0.0%	0.0%	9.1%	0.0%	0.0%	12.5%	5.6%	0.0%	0.0%	0.0%	0.0%	
Pedestrians	0	0	0	0	0	0	0	0	0	0	0	1	0	0	0	0	0	0	
% Pedestrians	0.0%	0.0%	0.0%	0.0%	0.0%	0.0%	0.0%	0.0%	0.0%	0.0%	0.0%	100.0%	0.0%	0.0%	0.0%	0.0%	0.0%	0.0%	
Bicycles on Crosswalk	0	0	0	0	0	0	0	0	0	0	0	0	0	0	0	0	0	0	
% Bicycles on Crosswalk	0.0%	0.0%	0.0%	0.0%	0.0%	0.0%	0.0%	0.0%	0.0%	0.0%	0.0%	0.0%	0.0%	0.0%	0.0%	0.0%	0.0%	0.0%	

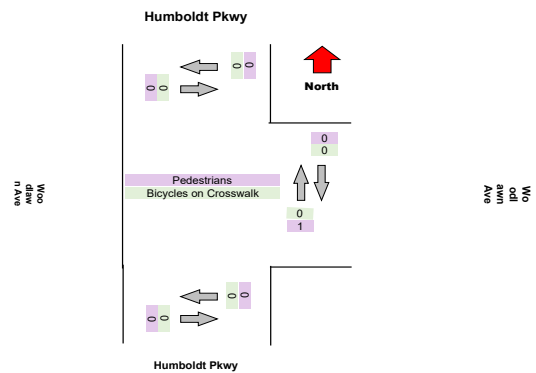
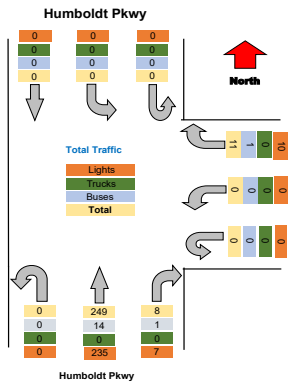

Turning Movement Peak Hour Data (PM)
 4:30:00 PM

Leg	Humboldt Pkwy						Woodlawn Ave						Humboldt Pkwy						Total							
	Southbound						Westbound						Northbound													
Direction	Thru	Left	U-Turn	App	Total		Right	Left	U-Turn	App	Total	Peds	CW	Peds	CCW	Right	Thru	U-Turn	App	Total	Peds	CW	Peds	CCW		
4:30:00 PM	0	0	0	0	0	0	3	0	0	3	0	0	2	78	0	80	0	0	0	80	0	0	0	0	0	83
4:45:00 PM	0	0	0	0	0	0	9	0	0	9	0	0	1	74	0	75	0	0	0	75	0	0	0	0	0	84
5:00:00 PM	0	0	0	0	0	0	4	0	0	4	2	1	0	82	0	82	0	0	0	82	0	0	0	0	0	86
5:15:00 PM	0	0	0	0	0	0	3	0	0	3	1	1	0	84	0	84	0	0	0	84	0	0	0	0	0	87
Grand Total	0	0	0	0	0	0	19	0	0	19	3	2	3	318	0	321	0	0	0	321	0	0	0	0	340	
% Approach	#####	#####	#####	0.0%	0.0%	0.0%	14.2%	0.0%	0.0%	0.0%	0.0%	0.0%	45.1%	41.7%	0.0%	0.0%	0.0%	0.0%	0.0%	0.0%	0.0%	0.0%	0.0%	0.0%	0.0%	
% Total	0.0%	0.0%	0.0%	0.0%	0.0%	0.0%	5.6%	0.0%	0.0%	5.6%	0.0%	0.0%	0.9%	93.5%	0.0%	94.4%	0.0%	0.0%	0.0%	0.0%	0.0%	0.0%	0.0%	0.0%	0.0%	
PHF	0.000	0.000	0.000	0.000	0.000	0.000	0.528	0.000	0.000	0.528	0.000	0.000	0.375	0.946	0.000	0.955	0.000	0.000	0.000	0.000	0.000	0.000	0.000	0.000	0.000	0.977
Lights	0	0	0	0	0	0	17	0	0	17	0	0	3	308	0	311	0	0	0	0	0	0	0	0	0	328
% Lights	0.0%	0.0%	0.0%	0.0%	0.0%	0.0%	89.5%	0.0%	0.0%	89.5%	0.0%	0.0%	100.0%	96.9%	0.0%	96.9%	0.0%	0.0%	0.0%	0.0%	0.0%	0.0%	0.0%	0.0%	0.0%	96.5%
Trucks	0	0	0	0	0	0	0	0	0	0	0	0	0	0	0	0	0	0	0	0	0	0	0	0	0	0
% Trucks	0.0%	0.0%	0.0%	0.0%	0.0%	0.0%	0.0%	0.0%	0.0%	0.0%	0.0%	0.0%	0.0%	0.0%	0.0%	0.0%	0.0%	0.0%	0.0%	0.0%	0.0%	0.0%	0.0%	0.0%	0.0%	0.0%
Buses	0	0	0	0	0	0	2	0	0	2	0	0	0	10	0	10	0	0	0	0	0	0	0	0	0	12
% Buses	0.0%	0.0%	0.0%	0.0%	0.0%	0.0%	10.5%	0.0%	0.0%	10.5%	0.0%	0.0%	0.0%	3.1%	0.0%	3.1%	0.0%	0.0%	0.0%	0.0%	0.0%	0.0%	0.0%	0.0%	0.0%	3.5%
Pedestrians	0	0	0	0	0	0	0	0	0	0	3	1	0	0	0	0	0	0	0	0	0	0	0	0	0	0
% Pedestrians	0.0%	0.0%	0.0%	0.0%	0.0%	0.0%	0.0%	0.0%	0.0%	0.0%	100.0%	50.0%	0.0%	0.0%	0.0%	0.0%	0.0%	0.0%	0.0%	0.0%	0.0%	0.0%	0.0%	0.0%	0.0%	0.0%
Bicycles on Crosswalk	0	0	0	0	0	0	0	0	0	0	0	1	0	0	0	0	0	0	0	0	0	0	0	0	0	0
% Bicycles on Crosswalk	0.0%	0.0%	0.0%	0.0%	0.0%	0.0%	0.0%	0.0%	0.0%	0.0%	0.0%	50.0%	0.0%	0.0%	0.0%	0.0%	0.0%	0.0%	0.0%	0.0%	0.0%	0.0%	0.0%	0.0%	0.0%	0.0%

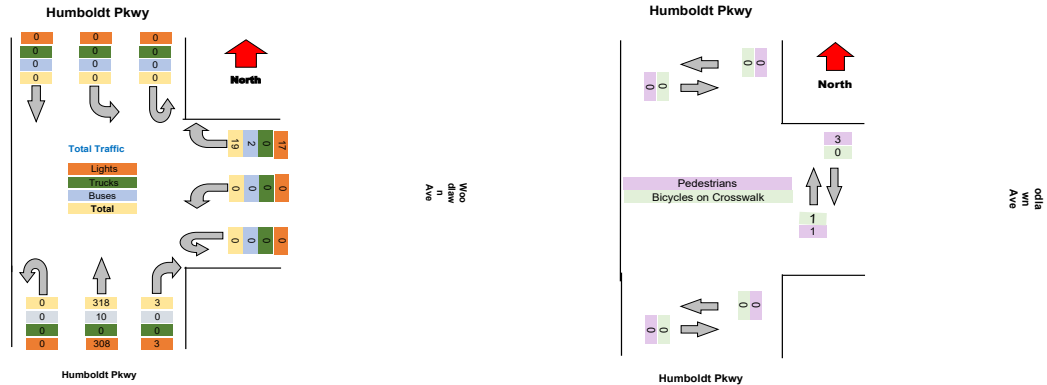

Turning Movement Data Plot

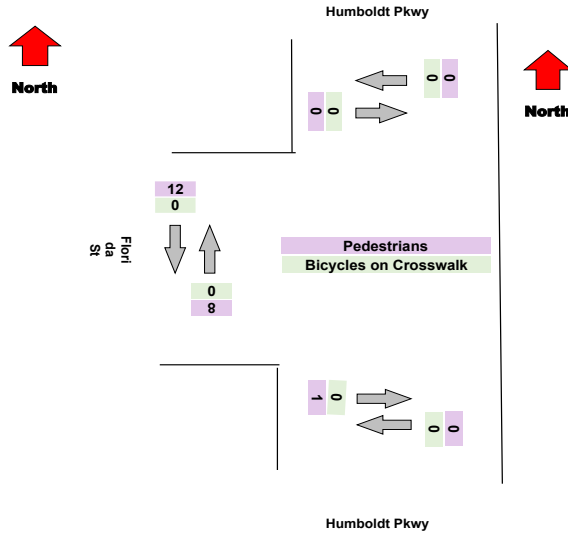
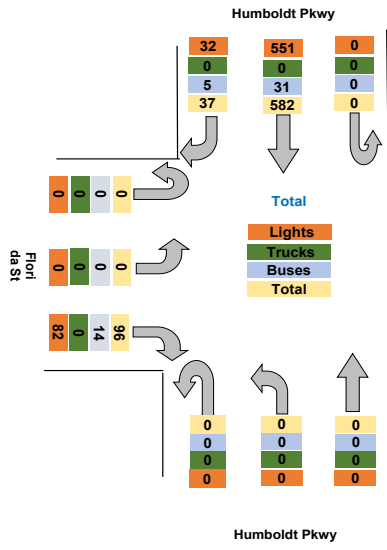

Turning Movement Peak Hour Data (AM)

7:30:00 AM

Leg Direction	Humboldt Pkwy Southbound						Humboldt Pkwy NorthBound						Florida St Eastbound					
	Right	Thru	U-Turn	App Total	Peds CW	Peds CCW	Thru	Left	U-Turn	App Total	Peds CW	Peds CCW	Right	Left	U-Turn	App Total	Peds CW	Peds CCW
7:30:00 AM	2	30	0	32	0	0	0	0	0	0	0	0	9	0	0	9	1	0
7:45:00 AM	0	26	0	26	0	0	0	0	0	0	0	0	6	0	0	6	1	0
8:00:00 AM	2	34	0	36	0	0	0	0	0	0	0	0	3	0	0	3	0	1
8:15:00 AM	3	38	0	41	0	0	0	0	0	0	1	0	3	0	0	4	1	0
Grand Total	7	128	0	135	0	0	0	0	0	0	1	0	21	0	0	22	3	1
% Approach	5.2%	94.8%	0.0%	0.0%	0.0%	0.0%	14.2%	0.0%	0.0%	0.0%	0.0%	0.0%	45.1%	41.7%	0.0%	0.0%	0.0%	0.0%
% Total	4.5%	81.5%	0.0%	86.0%	0.0%	0.0%	0.0%	0.0%	0.0%	0.0%	0.0%	0.0%	13.4%	0.0%	0.0%	14.0%	0.0%	0.0%
PHF	0.583	0.842	0.000	0.823	0.000	0.000	0.000	0.000	0.000	0.000	0.000	0.000	0.583	0.000	0.000	0.611	0.000	0.000
Lights	7	122	0	129	0	0	0	0	0	0	0	0	17	0	0	17	0	0
% Lights	100.0%	95.3%	0.0%	95.6%	0.0%	0.0%	0.0%	0.0%	0.0%	0.0%	0.0%	0.0%	81.0%	0.0%	0.0%	77.3%	0.0%	0.0%
Trucks	0	0	0	0	0	0	0	0	0	0	0	0	0	0	0	0	0	0
% Trucks	0.0%	0.0%	0.0%	0.0%	0.0%	0.0%	0.0%	0.0%	0.0%	0.0%	0.0%	0.0%	0.0%	0.0%	0.0%	0.0%	0.0%	0.0%
Buses	0	6	0	6	0	0	0	0	0	0	0	0	4	0	0	4	0	0
% Buses	0.0%	4.7%	0.0%	0.0%	0.0%	0.0%	0.0%	0.0%	0.0%	0.0%	0.0%	0.0%	19.0%	0.0%	0.0%	0.0%	0.0%	0.0%
Pedestrians	0	0	0	0	0	0	0	0	0	0	1	0	0	0	0	0	3	1
% Pedestrians	0.0%	0.0%	0.0%	0.0%	0.0%	0.0%	0.0%	0.0%	0.0%	0.0%	100.0%	0.0%	0.0%	0.0%	0.0%	100.0%	100.0%	100.0%
Bicycles on Crosswalk	0	0	0	0	0	0	0	0	0	0	0	0	0	0	0	0	0	0
% Bicycles on Crosswalk	0.0%	0.0%	0.0%	0.0%	0.0%	0.0%	0.0%	0.0%	0.0%	0.0%	0.0%	0.0%	0.0%	0.0%	0.0%	0.0%	0.0%	0.0%

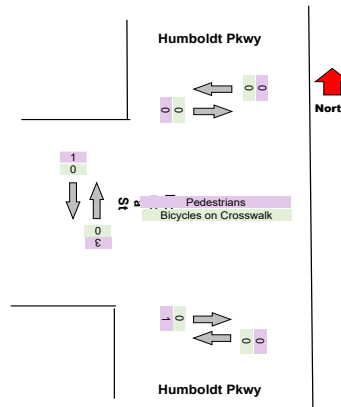
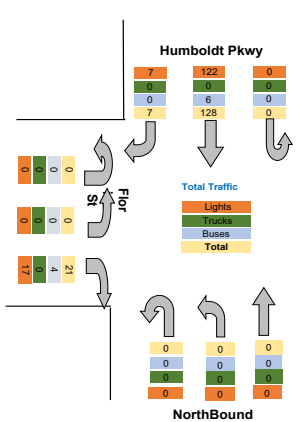

Turning Movement Peak Hour Data (PM)

4:30:00 PM

Leg Direction	Humboldt Pkwy Southbound						Humboldt Pkwy NorthBound						Florida St Eastbound									
	Right	Thru	U-Turn	App	Total	Peds CW	Peds CCW	Thru	Left	U-Turn	App	Total	Peds CW	Peds CCW	Right	Left	U-Turn	App	Total	Peds CW	Peds CCW	
4:30:00 PM	5	55	0		60	0	0	0	0	0	0	0	0	0	8	0	0		8	1	1	
4:45:00 PM	4	45	0		49	0	0	0	0	0	0	0	0	0	12	0	0		12	0	1	
5:00:00 PM	4	50	0		54	0	0	0	0	0	0	0	0	0	9	0	0		9	0	0	
5:15:00 PM	2	39	0		41	0	0	0	0	0	0	0	0	0	6	0	0		6	0	0	
Grand Total	15	189	0		204	0	0	0	0	0	0	0	0	0	35	0	0		35	1	2	
% Approach	7.4%	92.6%	0.0%		0.0%	0.0%	0.0%	14.2%	0.0%	0.0%	0.0%	0.0%	0.0%	0.0%	45.1%	41.7%	0.0%		0.0%	0.0%	0.0%	
% Total	6.3%	79.1%	0.0%		85.4%	0.0%	0.0%	0.0%	0.0%	0.0%	0.0%	0.0%	0.0%	0.0%	14.6%	0.0%	0.0%		14.6%	0.0%	0.0%	
PHF	0.750	0.859	0.000		0.850	0.000	0.000	0.000	0.000	0.000	0.000	0.000	0.000	0.000	0.729	0.000	0.000		0.729	0.000	0.000	
Lights	11	184	0		195	0	0	0	0	0	0	0	0	0	32	0	0		32	0	0	
% Lights	73.3%	97.4%	0.0%		95.6%	0.0%	0.0%	0.0%	0.0%	0.0%	0.0%	0.0%	0.0%	0.0%	91.4%	0.0%	0.0%		91.4%	0.0%	0.0%	
Trucks	0	0	0		0	0	0	0	0	0	0	0	0	0	0	0	0		0	0	0	
% Trucks	0.0%	0.0%	0.0%		0.0%	0.0%	0.0%	0.0%	0.0%	0.0%	0.0%	0.0%	0.0%	0.0%	0.0%	0.0%	0.0%		0.0%	0.0%	0.0%	
Buses	4	5	0		9	0	0	0	0	0	0	0	0	0	3	0	0		3	0	0	
% Buses	26.7%	2.6%	0.0%		0.0%	0.0%	0.0%	0.0%	0.0%	0.0%	0.0%	0.0%	0.0%	0.0%	8.6%	0.0%	0.0%		0.0%	0.0%	0.0%	
Pedestrians	0	0	0		0	0	0	0	0	0	0	0	0	0	0	0	0		0	1	2	
% Pedestrians	0.0%	0.0%	0.0%		0.0%	0.0%	0.0%	0.0%	0.0%	0.0%	0.0%	0.0%	0.0%	0.0%	0.0%	0.0%	0.0%		0.0%	100.0%	100.0%	
Bicycles on Crosswalk	0	0	0		0	0	0	0	0	0	0	0	0	0	0	0	0		0	0	0	
% Bicycles on Crosswalk	0.0%	0.0%	0.0%		0.0%	0.0%	0.0%	0.0%	0.0%	0.0%	0.0%	0.0%	0.0%	0.0%	0.0%	0.0%	0.0%		0.0%	0.0%	0.0%	

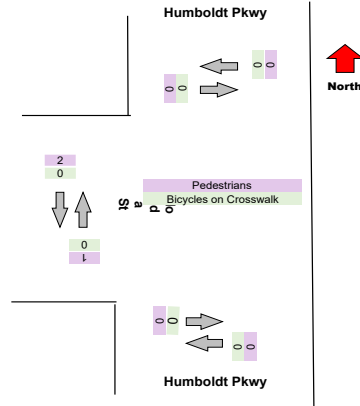
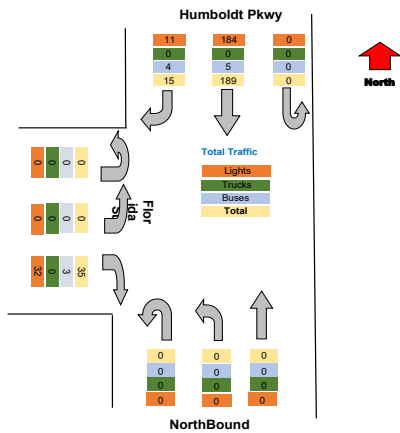

Intersection: Elm St Pine St
 Location: Kennett Square, PA
 Site: 01
 Survey Date: Wednesday, 04-28-2021
 GPS: 42.948550, -72.790034



Total
15
25
40
18
38
41
32
129
39
45
84
73
73
68
61
275
63
47
37
41
188
716
0.0%
0.0%
665
92.9%
0
0.0%
50
7.0%
0
0.0%
0.0%

Intersection: Elm St Pine St
Location: Kennett Square, PA
Site: 01
Survey Date: Wednesday, 04-28-2021
GPS: 42.948550, -72.790034



Total
41
32
39
45
157
0.872
146
93.0%
0
0.0%
10
6.4%
0
0.0%
0
0.0%

Intersection: Elm St Pine St
Location: Kennett Square, PA
Site: 01
Survey Date: Wednesday, 04-28-2021
GPS: 42.948550, -72.790034



Total
68
61
63
47
239
0.879
227
95.0%
0
0.0%
12
5.0%
0
0.0%
0
0.0%

Turning Movement Data Plot

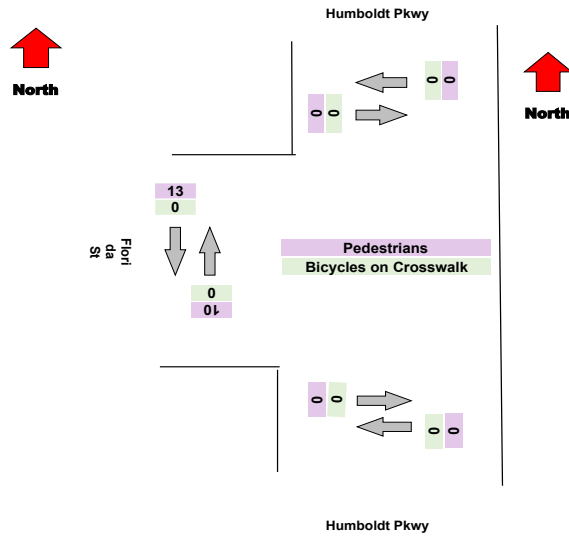
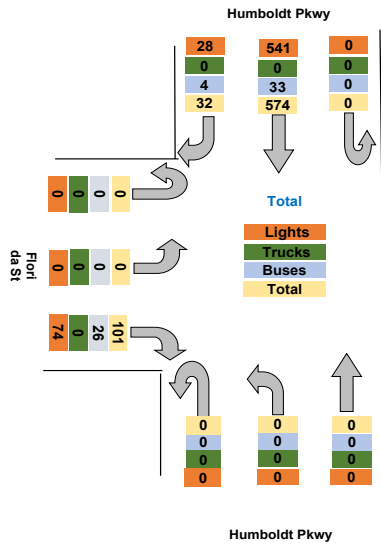

Turning Movement Peak Hour Data (AM)

7:30:00 AM

Leg Direction	Humboldt Pkwy Southbound						Humboldt Pkwy NorthBound						Florida St Eastbound						Total				
	Right	Thru	U-Turn	App	Total	Peds CW	Peds CCW	Thru	Left	U-Turn	App	Total	Peds CW	Peds CCW	Right	Left	U-Turn	App		Total	Peds CW	Peds CCW	
7:30:00 AM	0	29	0	29	0	0	0	0	0	0	0	0	0	0	7	0	0	7	1	0	0	0	36
7:45:00 AM	0	37	0	37	0	0	0	0	0	0	0	0	0	0	2	0	0	2	0	0	1	0	39
8:00:00 AM	3	29	0	32	0	0	0	0	0	0	0	0	0	0	5	0	0	5	3	0	0	0	37
8:15:00 AM	3	29	0	32	0	0	0	0	0	0	0	0	0	0	8	0	0	8	0	0	0	0	40
Grand Total	6	124	0	130	0	0	0	0	0	0	0	0	0	0	22	0	0	22	4	1	0	0	152
% Approach	4.6%	95.4%	0.0%	0.0%	0.0%	0.0%	14.2%	0.0%	0.0%	0.0%	0.0%	0.0%	0.0%	0.0%	45.1%	41.7%	0.0%	0.0%	0.0%	0.0%	0.0%	0.0%	0.0%
% Total	3.9%	81.6%	0.0%	85.5%	0.0%	0.0%	0.0%	0.0%	0.0%	0.0%	0.0%	0.0%	0.0%	0.0%	14.5%	0.0%	0.0%	14.5%	0.0%	0.0%	0.0%	0.0%	0.0%
PHF	0.500	0.838	0.000	0.878	0.000	0.000	0.000	0.000	0.000	0.000	0.000	0.000	0.000	0.000	0.688	0.000	0.000	0.688	0.000	0.000	0.000	0.000	0.950
Lights	4	117	0	121	0	0	0	0	0	0	0	0	0	0	17	0	0	17	0	0	0	0	138
% Lights	66.7%	94.4%	0.0%	93.1%	0.0%	0.0%	0.0%	0.0%	0.0%	0.0%	0.0%	0.0%	0.0%	0.0%	77.3%	0.0%	0.0%	77.3%	0.0%	0.0%	0.0%	0.0%	90.8%
Trucks	0	0	0	0	0	0	0	0	0	0	0	0	0	0	0	0	0	0	0	0	0	0	0
% Trucks	0.0%	0.0%	0.0%	0.0%	0.0%	0.0%	0.0%	0.0%	0.0%	0.0%	0.0%	0.0%	0.0%	0.0%	0.0%	0.0%	0.0%	0.0%	0.0%	0.0%	0.0%	0.0%	0.0%
Buses	2	7	0	9	0	0	0	0	0	0	0	0	0	0	5	0	0	5	0	0	0	0	14
% Buses	33.3%	5.6%	0.0%	0.0%	0.0%	0.0%	0.0%	0.0%	0.0%	0.0%	0.0%	0.0%	0.0%	0.0%	22.7%	0.0%	0.0%	0.0%	0.0%	0.0%	0.0%	0.0%	9.2%
Pedestrians	0	0	0	0	0	0	0	0	0	0	0	0	0	0	0	0	0	0	0	4	1	0	0
% Pedestrians	0.0%	0.0%	0.0%	0.0%	0.0%	0.0%	0.0%	0.0%	0.0%	0.0%	0.0%	0.0%	0.0%	0.0%	0.0%	0.0%	0.0%	0.0%	0.0%	100.0%	100.0%	0.0%	0.0%
Bicycles on Crosswalk	0	0	0	0	0	0	0	0	0	0	0	0	0	0	0	0	0	0	0	0	0	0	0
% Bicycles on Crosswalk	0.0%	0.0%	0.0%	0.0%	0.0%	0.0%	0.0%	0.0%	0.0%	0.0%	0.0%	0.0%	0.0%	0.0%	0.0%	0.0%	0.0%	0.0%	0.0%	0.0%	0.0%	0.0%	0.0%

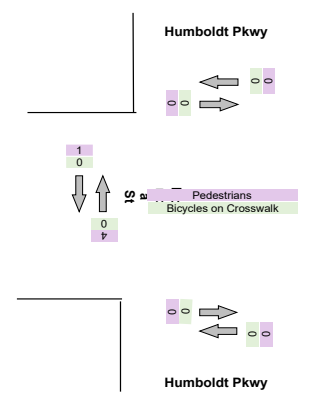
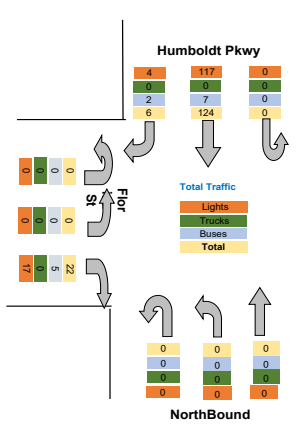

Turning Movement Peak Hour Data (PM)

4:30:00 PM

Leg Direction	Humboldt Pkwy Southbound						Humboldt Pkwy NorthBound						Florida St Eastbound						Total
	Right	Thru	U-Turn	App Total	Peds CW	Peds CCW	Thru	Left	U-Turn	App Total	Peds CW	Peds CCW	Right	Left	U-Turn	App Total	Peds CW	Peds CCW	
4:30:00 PM	1	51	0	52	0	0	0	0	0	0	0	0	6	0	0	6	1	5	58
4:45:00 PM	2	45	0	47	0	0	0	0	0	0	0	0	10	0	0	10	1	2	57
5:00:00 PM	4	40	0	44	0	0	0	0	0	0	0	0	15	0	0	15	1	1	59
5:15:00 PM	3	42	0	45	0	0	0	0	0	0	0	0	4	0	0	4	0	0	49
Grand Total	10	178	0	188	0	0	0	0	0	0	0	0	35	0	0	35	3	8	223
% Approach	5.3%	94.7%	0.0%	0.0%	0.0%	0.0%	14.2%	0.0%	0.0%	0.0%	0.0%	0.0%	45.1%	41.7%	0.0%	0.0%	0.0%	0.0%	0.0%
% Total	4.5%	79.8%	0.0%	84.3%	0.0%	0.0%	0.0%	0.0%	0.0%	0.0%	0.0%	0.0%	15.7%	0.0%	0.0%	15.7%	0.0%	0.0%	0.0%
PHF	0.625	0.873	0.000	0.904	0.000	0.000	0.000	0.000	0.000	0.000	0.000	0.000	0.583	0.000	0.000	0.583	0.000	0.000	0.945
Lights	9	173	0	182	0	0	0	0	0	0	0	0	28	0	0	28	0	0	210
% Lights	90.0%	97.2%	0.0%	96.8%	0.0%	0.0%	0.0%	0.0%	0.0%	0.0%	0.0%	0.0%	80.0%	0.0%	0.0%	80.0%	0.0%	0.0%	94.2%
Trucks	0	0	0	0	0	0	0	0	0	0	0	0	0	0	0	0	0	0	0
% Trucks	0.0%	0.0%	0.0%	0.0%	0.0%	0.0%	0.0%	0.0%	0.0%	0.0%	0.0%	0.0%	0.0%	0.0%	0.0%	0.0%	0.0%	0.0%	0.0%
Buses	1	5	0	6	0	0	0	0	0	0	0	0	6	0	0	6	0	0	12
% Buses	10.0%	2.8%	0.0%	0.0%	0.0%	0.0%	0.0%	0.0%	0.0%	0.0%	0.0%	0.0%	17.1%	0.0%	0.0%	0.0%	0.0%	0.0%	5.4%
Pedestrians	0	0	0	0	0	0	0	0	0	0	0	0	0	0	0	0	3	8	0
% Pedestrians	0.0%	0.0%	0.0%	0.0%	0.0%	0.0%	0.0%	0.0%	0.0%	0.0%	0.0%	0.0%	0.0%	0.0%	0.0%	0.0%	100.0%	100.0%	0.0%
Bicycles on Crosswalk	0	0	0	0	0	0	0	0	0	0	0	0	0	0	0	0	0	0	0
% Bicycles on Crosswalk	0.0%	0.0%	0.0%	0.0%	0.0%	0.0%	0.0%	0.0%	0.0%	0.0%	0.0%	0.0%	0.0%	0.0%	0.0%	0.0%	0.0%	0.0%	0.0%

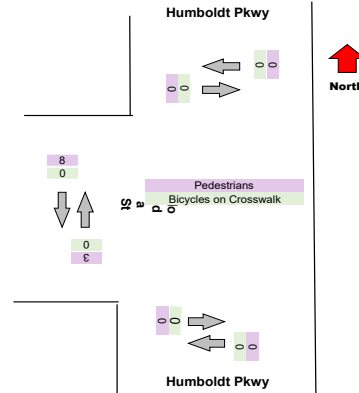
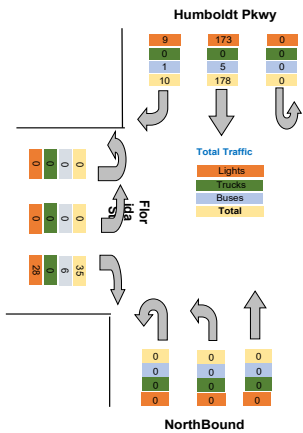

Intersection: Elm St Pine St
 Location: Kennett Square, PA
 Site: 01
 Survey Date: Wednesday, 04-28-2021
 GPS: 42.948550, -72.790034



TSTData.com

Project	Labella
Project Code	Labella
Site Name	J
Legs and Movements	All Processed Legs & Movement
Bin Size	15 minutes
Survey Date	2021-10-28, Thursday
Location	J
Latitude and Longitude	42.920093, -78.843735

	Start	End	PHF
Forced Peak AM	2021/10/28 07:30:00	2021/10/28 08:30:00	0.94
Forced Peak PM	2021/10/28 16:30:00	2021/10/28 17:30:00	0.95
AM Peak	2021/10/28 07:30:00	2021/10/28 08:30:00	0.94
PM Peak	2021/10/28 16:30:00	2021/10/28 17:30:00	0.95

Turning Movement Data

Leg Direction	Humboldt Pkwy Southbound						Humboldt Pkwy Northbound						Florida St Eastbound						Total
	Right	Thru	U-Turn	App Total	Peds CW	Peds CCW	Thru	Left	U-Turn	App Total	Peds CW	Peds CCW	Right	Left	U-Turn	App Total	Peds CW	Peds CCW	
Start Time																			
6:30:00 AM	0	14	0	14	0	0	0	0	0	0	0	0	3	0	0	3	0	0	17
6:45:00 AM	1	15	0	16	0	0	0	0	0	0	0	0	3	0	0	3	0	0	19
Hourly Total	1	29	0	30	0	0	0	0	0	0	0	0	6	0	0	6	0	0	36
7:00:00 AM	2	20	0	22	0	0	0	0	0	0	0	0	3	0	0	3	0	0	25
7:15:00 AM	0	14	0	14	0	0	0	0	0	0	0	0	8	0	0	8	1	0	22
7:30:00 AM	1	31	0	32	0	0	0	0	0	0	0	1	7	0	0	8	1	0	40
7:45:00 AM	2	35	0	37	0	0	0	0	0	0	0	0	6	0	0	6	0	0	43
Hourly Total	5	100	0	105	0	0	0	0	0	0	0	1	24	0	0	25	2	0	130
8:00:00 AM	2	36	0	38	0	0	0	0	0	0	0	0	6	0	0	6	0	0	44
8:15:00 AM	5	33	0	38	0	0	0	0	0	0	0	0	8	0	0	8	0	0	46
Hourly Total	7	69	0	76	0	0	0	0	0	0	0	0	14	0	0	14	0	0	90
4:00:00 PM	3	40	0	43	0	0	0	0	0	0	0	0	7	0	0	7	0	5	50
4:15:00 PM	3	41	0	44	0	0	0	0	0	0	0	0	10	0	0	10	1	0	54
4:30:00 PM	3	48	0	51	0	0	0	0	0	0	0	0	14	0	0	14	0	1	65
4:45:00 PM	3	49	0	52	0	0	0	0	0	0	0	0	11	0	0	11	1	1	63
Hourly Total	12	178	0	190	0	0	0	0	0	0	0	0	42	0	0	42	2	7	232
5:00:00 PM	4	49	0	53	0	0	0	0	0	0	0	0	7	0	0	7	0	0	60
5:15:00 PM	0	48	0	48	0	0	0	0	0	0	0	0	11	0	0	11	0	0	59
5:30:00 PM	3	41	0	44	0	0	0	0	0	0	0	0	4	0	0	4	0	1	48
5:45:00 PM	2	43	0	45	0	0	0	0	0	0	0	0	6	0	0	6	0	0	51
Hourly Total	9	181	0	190	0	0	0	0	0	0	0	0	28	0	0	28	0	1	218
Grand Total	34	557	0	591	0	0	0	0	0	0	0	1	114	0	0	115	4	8	706
% Approach	5.8%	94.2%	0.0%	0.0%	0.0%	0.0%	0.0%	0.0%	0.0%	0.0%	0.0%	0.0%	99.1%	0.0%	0.0%	0.0%	0.0%	0.0%	0.0%
% Total	4.8%	78.9%	0.0%	83.7%	0.0%	0.0%	0.0%	0.0%	0.0%	0.0%	0.0%	0.0%	16.1%	0.0%	0.0%	16.3%	0.0%	0.0%	0.0%
Lights	28	531	0	559	0	0	0	0	0	0	0	0	94	0	0	94	0	0	653
% Lights	82.4%	95.3%	0.0%	94.6%	0.0%	0.0%	0.0%	0.0%	0.0%	0.0%	0.0%	0.0%	82.5%	0.0%	0.0%	81.7%	0.0%	0.0%	92.5%
Trucks	0	1	0	1	0	0	0	0	0	0	0	0	0	0	0	0	0	0	1
% Trucks	0.0%	0.2%	0.0%	0.2%	0.0%	0.0%	0.0%	0.0%	0.0%	0.0%	0.0%	0.0%	0.0%	0.0%	0.0%	0.0%	0.0%	0.0%	0.1%
Buses	6	24	0	30	0	0	0	0	0	0	0	0	19	0	0	19	0	0	49
% Buses	17.6%	4.3%	0.0%	0.0%	0.0%	0.0%	0.0%	0.0%	0.0%	0.0%	0.0%	0.0%	16.7%	0.0%	0.0%	0.0%	0.0%	0.0%	6.9%
Pedestrians	0	0	0	0	0	0	0	0	0	0	1	0	0	0	0	0	4	7	0
% Pedestrians	0.0%	0.0%	0.0%	0.0%	0.0%	0.0%	0.0%	0.0%	0.0%	0.0%	100.0%	0.0%	0.0%	0.0%	0.0%	0.0%	100.0%	87.5%	0.0%
% Bicycles on Crosswalk	0.0%	0.0%	0.0%	0.0%	0.0%	0.0%	0.0%	0.0%	0.0%	0.0%	0.0%	0.0%	0.0%	0.0%	0.0%	0.0%	0.0%	12.5%	0.0%

Turning Movement Data Plot

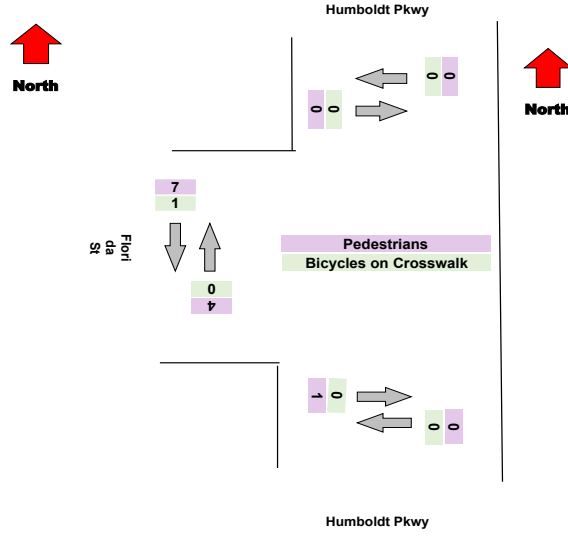
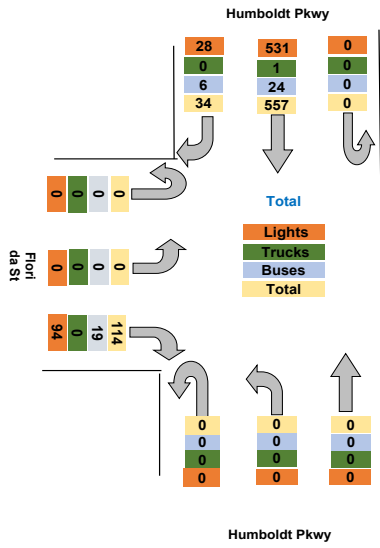

Turning Movement Peak Hour Data (AM)

7:30:00 AM

Leg Direction	Humboldt Pkwy Southbound						Humboldt Pkwy NorthBound						Florida St Eastbound						Total				
	Right	Thru	U-Turn	App	Total	Peds CW	Peds CCW	Thru	Left	U-Turn	App	Total	Peds CW	Peds CCW	Right	Left	U-Turn	App		Total	Peds CW	Peds CCW	
7:30:00 AM	1	31	0	32	0	0	0	0	0	0	0	0	0	0	1	7	0	0	8	1	0	0	40
7:45:00 AM	2	35	0	37	0	0	0	0	0	0	0	0	0	0	6	0	0	6	0	0	0	0	43
8:00:00 AM	2	36	0	38	0	0	0	0	0	0	0	0	0	0	6	0	0	6	0	0	0	0	44
8:15:00 AM	5	33	0	38	0	0	0	0	0	0	0	0	0	0	8	0	0	8	0	0	0	0	46
Grand Total	10	135	0	145	0	0	0	0	0	0	0	0	0	1	27	0	0	28	1	0	0	0	173
% Approach	6.9%	93.1%	0.0%	0.0%	0.0%	0.0%	14.2%	0.0%	0.0%	0.0%	0.0%	0.0%	0.0%	0.0%	45.1%	41.7%	0.0%	0.0%	0.0%	0.0%	0.0%	0.0%	0.0%
% Total	5.8%	78.0%	0.0%	83.8%	0.0%	0.0%	0.0%	0.0%	0.0%	0.0%	0.0%	0.0%	0.0%	0.0%	15.6%	0.0%	0.0%	16.2%	0.0%	0.0%	0.0%	0.0%	0.0%
PHF	0.500	0.938	0.000	0.954	0.000	0.000	0.000	0.000	0.000	0.000	0.000	0.000	0.000	0.000	0.844	0.000	0.000	0.875	0.000	0.000	0.000	0.000	0.940
Lights	8	129	0	137	0	0	0	0	0	0	0	0	0	0	23	0	0	23	0	0	0	0	160
% Lights	80.0%	95.6%	0.0%	94.5%	0.0%	0.0%	0.0%	0.0%	0.0%	0.0%	0.0%	0.0%	0.0%	0.0%	85.2%	0.0%	0.0%	82.1%	0.0%	0.0%	0.0%	0.0%	92.5%
Trucks	0	1	0	1	0	0	0	0	0	0	0	0	0	0	0	0	0	0	0	0	0	0	1
% Trucks	0.0%	0.7%	0.0%	0.7%	0.0%	0.0%	0.0%	0.0%	0.0%	0.0%	0.0%	0.0%	0.0%	0.0%	0.0%	0.0%	0.0%	0.0%	0.0%	0.0%	0.0%	0.0%	0.6%
Buses	2	5	0	7	0	0	0	0	0	0	0	0	0	0	4	0	0	4	0	0	0	0	11
% Buses	20.0%	3.7%	0.0%	0.0%	0.0%	0.0%	0.0%	0.0%	0.0%	0.0%	0.0%	0.0%	0.0%	0.0%	14.8%	0.0%	0.0%	0.0%	0.0%	0.0%	0.0%	0.0%	6.4%
Pedestrians	0	0	0	0	0	0	0	0	0	0	0	0	1	0	0	0	0	0	0	1	0	0	0
% Pedestrians	0.0%	0.0%	0.0%	0.0%	0.0%	0.0%	0.0%	0.0%	0.0%	0.0%	0.0%	0.0%	100.0%	0.0%	0.0%	0.0%	0.0%	0.0%	0.0%	100.0%	0.0%	0.0%	0.0%
Bicycles on Crosswalk	0	0	0	0	0	0	0	0	0	0	0	0	0	0	0	0	0	0	0	0	0	0	0
% Bicycles on Crosswalk	0.0%	0.0%	0.0%	0.0%	0.0%	0.0%	0.0%	0.0%	0.0%	0.0%	0.0%	0.0%	0.0%	0.0%	0.0%	0.0%	0.0%	0.0%	0.0%	0.0%	0.0%	0.0%	0.0%

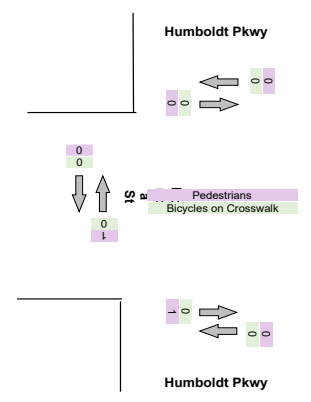
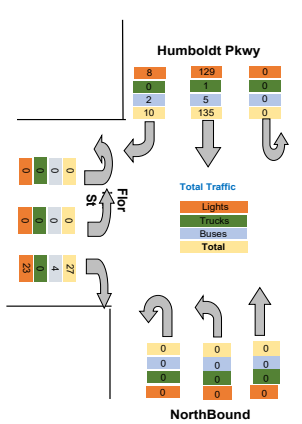

Turning Movement Peak Hour Data (PM)

4:30:00 PM

Leg Direction	Humboldt Pkwy Southbound						Humboldt Pkwy NorthBound						Florida St Eastbound						Total
	Right	Thru	U-Turn	App Total	Peds CW	Peds CCW	Thru	Left	U-Turn	App Total	Peds CW	Peds CCW	Right	Left	U-Turn	App Total	Peds CW	Peds CCW	
4:30:00 PM	3	48	0	51	0	0	0	0	0	0	0	0	14	0	0	14	0	1	65
4:45:00 PM	3	49	0	52	0	0	0	0	0	0	0	0	11	0	0	11	1	1	63
5:00:00 PM	4	49	0	53	0	0	0	0	0	0	0	0	7	0	0	7	0	0	60
5:15:00 PM	0	48	0	48	0	0	0	0	0	0	0	0	11	0	0	11	0	0	59
Grand Total	10	194	0	204	0	0	0	0	0	0	0	0	43	0	0	43	1	2	247
% Approach	4.9%	95.1%	0.0%	0.0%	0.0%	0.0%	14.2%	0.0%	0.0%	0.0%	0.0%	0.0%	45.1%	41.7%	0.0%	0.0%	0.0%	0.0%	0.0%
% Total	4.0%	78.5%	0.0%	82.6%	0.0%	0.0%	0.0%	0.0%	0.0%	0.0%	0.0%	0.0%	17.4%	0.0%	0.0%	17.4%	0.0%	0.0%	0.0%
PHF	0.625	0.990	0.000	0.962	0.000	0.000	0.000	0.000	0.000	0.000	0.000	0.000	0.768	0.000	0.000	0.768	0.000	0.000	0.950
Lights	8	189	0	197	0	0	0	0	0	0	0	0	38	0	0	38	0	0	235
% Lights	80.0%	97.4%	0.0%	96.6%	0.0%	0.0%	0.0%	0.0%	0.0%	0.0%	0.0%	0.0%	88.4%	0.0%	0.0%	88.4%	0.0%	0.0%	95.1%
Trucks	0	0	0	0	0	0	0	0	0	0	0	0	0	0	0	0	0	0	0
% Trucks	0.0%	0.0%	0.0%	0.0%	0.0%	0.0%	0.0%	0.0%	0.0%	0.0%	0.0%	0.0%	0.0%	0.0%	0.0%	0.0%	0.0%	0.0%	0.0%
Buses	2	4	0	6	0	0	0	0	0	0	0	0	4	0	0	4	0	0	10
% Buses	20.0%	2.1%	0.0%	0.0%	0.0%	0.0%	0.0%	0.0%	0.0%	0.0%	0.0%	0.0%	9.3%	0.0%	0.0%	0.0%	0.0%	0.0%	4.0%
Pedestrians	0	0	0	0	0	0	0	0	0	0	0	0	0	0	0	0	1	2	0
% Pedestrians	0.0%	0.0%	0.0%	0.0%	0.0%	0.0%	0.0%	0.0%	0.0%	0.0%	0.0%	0.0%	0.0%	0.0%	0.0%	0.0%	100.0%	100.0%	0.0%
Bicycles on Crosswalk	0	0	0	0	0	0	0	0	0	0	0	0	0	0	0	0	0	0	0
% Bicycles on Crosswalk	0.0%	0.0%	0.0%	0.0%	0.0%	0.0%	0.0%	0.0%	0.0%	0.0%	0.0%	0.0%	0.0%	0.0%	0.0%	0.0%	0.0%	0.0%	0.0%

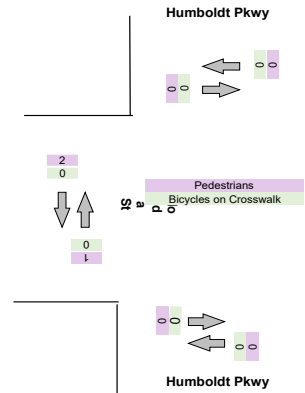
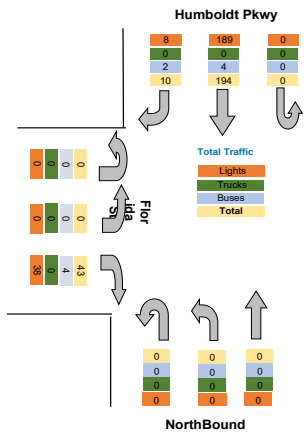

Project	Labella
Project Code	Labella
Site Name	K
Legs and Movements	All Processed Legs & Movement
Bin Size	15 minutes
Survey Date	2021-10-26, Tuesday
Location	K
Latitude and Longitude	42.919163, -78.843742

	Start	End	PHF
Forced Peak AM	2021/10/26 07:30:00	2021/10/26 08:30:00	0.906
Forced Peak PM	2021/10/26 16:30:00	2021/10/26 17:30:00	0.889
AM Peak	2021/10/26 07:30:00	2021/10/26 08:30:00	0.906
PM Peak	2021/10/26 16:30:00	2021/10/26 17:30:00	0.889

Turning Movement Data

Leg Direction	Humboldt Pkwy						Humboldt Pkwy						Northland Ave					
	Southbound						Northbound						Eastbound					
Start Time	Right	Thru	U-Turn	App Total	Peds CW	Peds CCW	Thru	Left	U-Turn	App Total	Peds CW	Peds CCW	Right	Left	U-Turn	App Total	Peds CW	Peds CCW
6:30:00 AM	0	13	0	13	0	0	0	0	0	0	0	0	5	0	0	5	1	0
6:45:00 AM	2	23	0	25	0	0	0	0	0	0	0	0	4	0	0	4	0	0
Hourly Total	2	36	0	38	0	0	0	0	0	0	0	0	9	0	0	9	1	0
7:00:00 AM	1	17	0	18	0	0	0	0	0	0	0	0	5	0	0	5	1	0
7:15:00 AM	6	31	0	37	0	0	0	0	0	0	0	0	6	0	0	6	0	1
7:30:00 AM	5	33	0	38	0	0	0	0	0	0	0	0	10	0	0	10	1	0
7:45:00 AM	6	27	0	33	0	0	0	0	0	0	0	0	7	0	0	7	1	0
Hourly Total	18	108	0	126	0	0	0	0	0	0	0	0	28	0	0	28	3	1
8:00:00 AM	5	32	0	37	0	0	0	0	0	0	0	0	2	0	0	2	0	0
8:15:00 AM	5	37	0	42	0	0	0	0	0	0	0	0	5	0	0	5	0	0
Hourly Total	10	69	0	79	0	0	0	0	0	0	0	0	7	0	0	7	0	0
4:00:00 PM	4	67	0	71	0	0	0	0	0	0	0	0	36	0	0	36	1	1
4:15:00 PM	9	55	0	64	0	0	0	0	0	0	0	0	16	0	0	16	1	1
4:30:00 PM	5	57	0	62	0	0	0	0	0	0	0	0	8	0	0	8	0	0
4:45:00 PM	9	49	0	58	0	0	0	0	0	0	0	0	4	0	0	4	0	1
Hourly Total	27	228	0	255	0	0	0	0	0	0	0	0	64	0	0	64	2	3
5:00:00 PM	3	53	0	56	0	0	0	0	0	0	0	0	9	0	0	9	0	0
5:15:00 PM	2	43	0	45	0	0	0	0	0	0	0	0	7	0	0	7	0	0
5:30:00 PM	3	35	0	38	0	0	0	0	0	0	0	0	9	0	0	9	0	0
5:45:00 PM	4	37	0	41	0	0	0	0	0	0	0	0	10	0	0	10	0	0
Hourly Total	12	168	0	180	0	0	0	0	0	0	0	0	35	0	0	35	0	0
Grand Total	69	609	0	678	0	0	0	0	0	0	0	0	143	0	0	143	6	4
% Approach	10.2%	89.8%	0.0%	0.0%	0.0%	0.0%	0.0%	0.0%	0.0%	0.0%	0.0%	0.0%	100.0%	0.0%	0.0%	0.0%	0.0%	0.0%
% Total	8.4%	74.2%	0.0%	82.6%	0.0%	0.0%	0.0%	0.0%	0.0%	0.0%	0.0%	0.0%	17.4%	0.0%	0.0%	17.4%	0.0%	0.0%
Lights	53	580	0	633	0	0	0	0	0	0	0	0	120	0	0	120	0	0
% Lights	76.8%	95.2%	0.0%	93.4%	0.0%	0.0%	0.0%	0.0%	0.0%	0.0%	0.0%	0.0%	83.9%	0.0%	0.0%	83.9%	0.0%	0.0%
Trucks	0	0	0	0	0	0	0	0	0	0	0	0	0	0	0	0	0	0
% Trucks	0.0%	0.0%	0.0%	0.0%	0.0%	0.0%	0.0%	0.0%	0.0%	0.0%	0.0%	0.0%	0.0%	0.0%	0.0%	0.0%	0.0%	0.0%
Buses	16	29	0	45	0	0	0	0	0	0	0	0	23	0	0	23	0	0
% Buses	23.2%	4.6%	0.0%	0.0%	0.0%	0.0%	0.0%	0.0%	0.0%	0.0%	0.0%	0.0%	16.1%	0.0%	0.0%	0.0%	0.0%	0.0%
Pedestrians	0	0	0	0	0	0	0	0	0	0	0	0	0	0	0	0	6	4
% Pedestrians	0.0%	0.0%	0.0%	0.0%	0.0%	0.0%	0.0%	0.0%	0.0%	0.0%	0.0%	0.0%	0.0%	0.0%	0.0%	0.0%	100.0%	100.0%
% Bicycles on Crosswalk	0.0%	0.0%	0.0%	0.0%	0.0%	0.0%	0.0%	0.0%	0.0%	0.0%	0.0%	0.0%	0.0%	0.0%	0.0%	0.0%	0.0%	0.0%

Turning Movement Data Plot

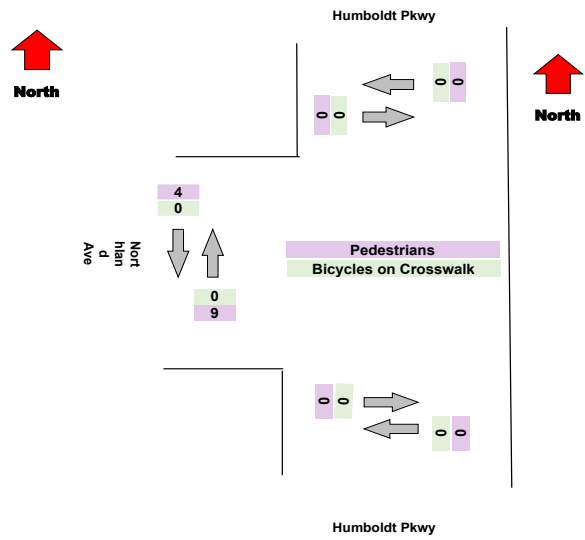
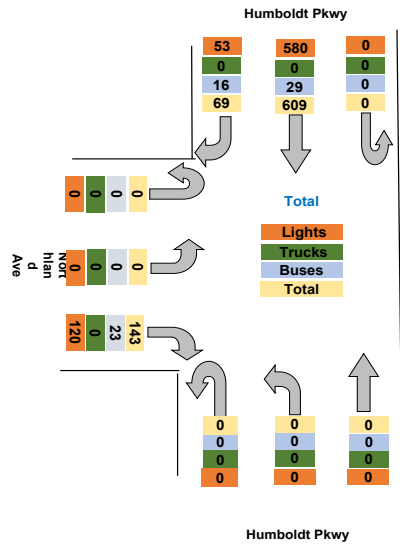

Turning Movement Peak Hour Data (AM)

7:30:00 AM

Leg Direction	Humboldt Pkwy Southbound						Humboldt Pkwy NorthBound						Northland Ave Eastbound					
	Right	Thru	U-Turn	App Total	Peds CW	Peds CCW	Thru	Left	U-Turn	App Total	Peds CW	Peds CCW	Right	Left	U-Turn	App Total	Peds CW	Peds CCW
7:30:00 AM	5	33	0	38	0	0	0	0	0	0	0	0	10	0	0	10	1	0
7:45:00 AM	6	27	0	33	0	0	0	0	0	0	0	0	7	0	0	7	1	0
8:00:00 AM	5	32	0	37	0	0	0	0	0	0	0	0	2	0	0	2	0	0
8:15:00 AM	5	37	0	42	0	0	0	0	0	0	0	0	5	0	0	5	0	0
Grand Total	21	129	0	150	0	0	0	0	0	0	0	0	24	0	0	24	2	0
% Approach	14.0%	86.0%	0.0%	0.0%	0.0%	0.0%	14.2%	0.0%	0.0%	0.0%	0.0%	0.0%	45.1%	41.7%	0.0%	0.0%	0.0%	0.0%
% Total	12.1%	74.1%	0.0%	86.2%	0.0%	0.0%	0.0%	0.0%	0.0%	0.0%	0.0%	0.0%	13.8%	0.0%	0.0%	13.8%	0.0%	0.0%
PHF	0.875	0.872	0.000	0.893	0.000	0.000	0.000	0.000	0.000	0.000	0.000	0.000	0.600	0.000	0.000	0.600	0.000	0.000
Lights	18	122	0	140	0	0	0	0	0	0	0	0	21	0	0	21	0	0
% Lights	85.7%	94.6%	0.0%	93.3%	0.0%	0.0%	0.0%	0.0%	0.0%	0.0%	0.0%	0.0%	87.5%	0.0%	0.0%	87.5%	0.0%	0.0%
Trucks	0	0	0	0	0	0	0	0	0	0	0	0	0	0	0	0	0	0
% Trucks	0.0%	0.0%	0.0%	0.0%	0.0%	0.0%	0.0%	0.0%	0.0%	0.0%	0.0%	0.0%	0.0%	0.0%	0.0%	0.0%	0.0%	0.0%
Buses	3	7	0	10	0	0	0	0	0	0	0	0	3	0	0	3	0	0
% Buses	14.3%	5.4%	0.0%	0.0%	0.0%	0.0%	0.0%	0.0%	0.0%	0.0%	0.0%	0.0%	12.5%	0.0%	0.0%	0.0%	0.0%	0.0%
Pedestrians	0	0	0	0	0	0	0	0	0	0	0	0	0	0	0	0	2	0
% Pedestrians	0.0%	0.0%	0.0%	0.0%	0.0%	0.0%	0.0%	0.0%	0.0%	0.0%	0.0%	0.0%	0.0%	0.0%	0.0%	0.0%	100.0%	0.0%
Bicycles on Crosswalk	0	0	0	0	0	0	0	0	0	0	0	0	0	0	0	0	0	0
% Bicycles on Crosswalk	0.0%	0.0%	0.0%	0.0%	0.0%	0.0%	0.0%	0.0%	0.0%	0.0%	0.0%	0.0%	0.0%	0.0%	0.0%	0.0%	0.0%	0.0%

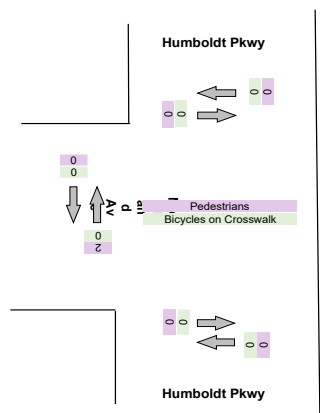
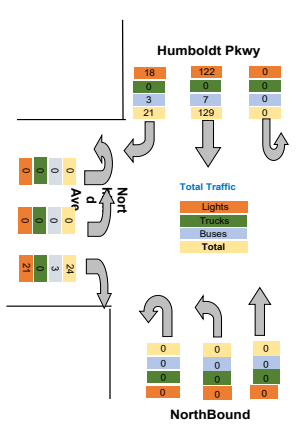

Turning Movement Peak Hour Data (PM)

4:30:00 PM

Leg Direction	Humboldt Pkwy Southbound						Humboldt Pkwy NorthBound						Northland Ave Eastbound					
	Right	Thru	U-Turn	App	Total	Peds CW/Peds CCW	Thru	Left	U-Turn	App	Total	Peds CW/Peds CCW	Right	Left	U-Turn	App	Total	Peds CW/Peds CCW
4:30:00 PM	5	57	0		62	0 0 0	0	0	0	0	0	0 0 0	8	0	0		8	0 0 0
4:45:00 PM	9	49	0		58	0 0 0	0	0	0	0	0	0 0 0	4	0	0		4	0 0 1
5:00:00 PM	3	53	0		56	0 0 0	0	0	0	0	0	0 0 0	9	0	0		9	0 0 0
5:15:00 PM	2	43	0		45	0 0 0	0	0	0	0	0	0 0 0	7	0	0		7	0 0 0
Grand Total	19	202	0		221	0 0 0	0	0	0	0	0	0 0 0	28	0	0		28	0 0 1
% Approach	8.6%	91.4%	0.0%		0.0%	0.0% 0.0% 0.0%	14.2%	0.0%	0.0%	0.0%	0.0% 0.0% 0.0%	45.1%	41.7%	0.0%		0.0%	0.0% 0.0%	
% Total	7.6%	81.1%	0.0%		88.8%	0.0% 0.0% 0.0%	0.0%	0.0%	0.0%	0.0%	0.0% 0.0% 0.0%	11.2%	0.0%	0.0%		11.2%	0.0% 0.0%	
PHF	0.528	0.886	0.000		0.891	0.000 0.000 0.000	0.000	0.000	0.000	0.000	0.000 0.000 0.000	0.778	0.000	0.000		0.778	0.000 0.000	
Lights	16	197	0		213	0 0 0	0	0	0	0	0 0 0	22	0	0		22	0 0 0	
% Lights	84.2%	97.5%	0.0%		96.4%	0.0% 0.0% 0.0%	0.0%	0.0%	0.0%	0.0%	0.0% 0.0% 0.0%	78.6%	0.0%	0.0%		78.6%	0.0% 0.0%	
Trucks	0	0	0		0	0 0 0	0	0	0	0	0 0 0	0	0	0		0	0 0 0	
% Trucks	0.0%	0.0%	0.0%		0.0%	0.0% 0.0% 0.0%	0.0%	0.0%	0.0%	0.0%	0.0% 0.0% 0.0%	0.0%	0.0%	0.0%		0.0%	0.0% 0.0%	
Buses	3	5	0		8	0 0 0	0	0	0	0	0 0 0	6	0	0		6	0 0 0	
% Buses	15.8%	2.5%	0.0%		0.0%	0.0% 0.0% 0.0%	0.0%	0.0%	0.0%	0.0%	0.0% 0.0% 0.0%	21.4%	0.0%	0.0%		0.0%	0.0% 0.0%	
Pedestrians	0	0	0		0	0 0 0	0	0	0	0	0 0 0	0	0	0		0	0 0 1	
% Pedestrians	0.0%	0.0%	0.0%		0.0%	0.0% 0.0% 0.0%	0.0%	0.0%	0.0%	0.0%	0.0% 0.0% 0.0%	0.0%	0.0%	0.0%		0.0%	0.0% 100.0%	
Bicycles on Crosswalk	0	0	0		0	0 0 0	0	0	0	0	0 0 0	0	0	0		0	0 0 0	
% Bicycles on Crosswalk	0.0%	0.0%	0.0%		0.0%	0.0% 0.0% 0.0%	0.0%	0.0%	0.0%	0.0%	0.0% 0.0% 0.0%	0.0%	0.0%	0.0%		0.0%	0.0% 0.0%	

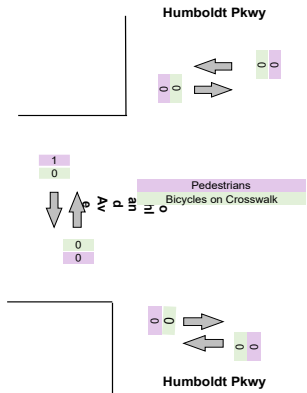
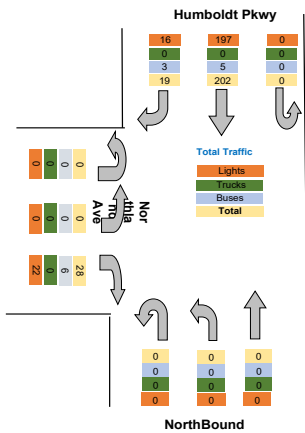

Intersection: Elm St Pine St
 Location: Kennett Square, PA
 Site: 01
 Survey Date: Wednesday, 04-28-2021
 GPS: 42.948550, -72.790034



Total
18
29
47
23
43
48
40
154
39
47
86
107
80
70
62
319
65
52
47
51
215
821
0.0%
0.0%
753
91.7%
0
0.0%
68
8.3%
0
0.0%
0.0%

Intersection: Elm St Pine St
Location: Kennett Square, PA
Site: 01
Survey Date: Wednesday, 04-28-2021
GPS: 42.948550, -72.790034



Total
48
40
39
47
174
0.906
161
92.5%
0
0.0%
13
7.5%
0
0.0%
0
0.0%

Intersection: Elm St Pine St
Location: Kennett Square, PA
Site: 01
Survey Date: Wednesday, 04-28-2021
GPS: 42.948550, -72.790034



Total
70
62
65
52
249
0.889
235
94.4%
0
0.0%
14
5.6%
0
0.0%
0
0.0%

Turning Movement Data Plot

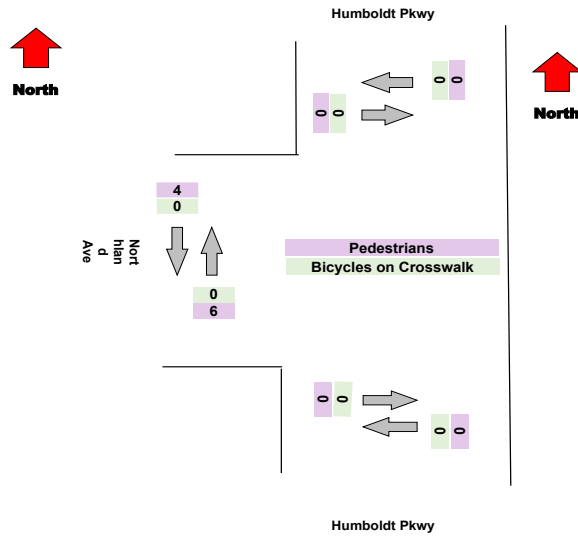
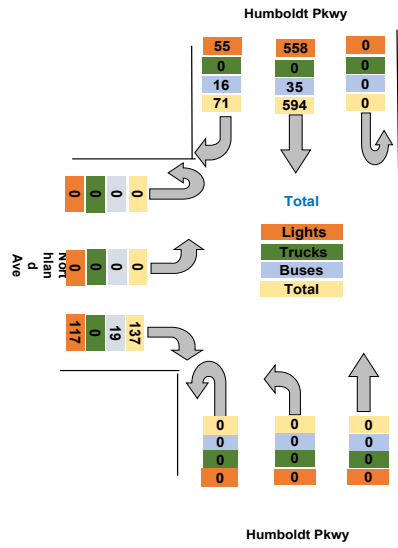

Turning Movement Peak Hour Data (AM)

7:30:00 AM

Leg Direction	Humboldt Pkwy Southbound						Humboldt Pkwy NorthBound						Northland Ave Eastbound					
	Right	Thru	U-Turn	App Total	Peds CW	Peds CCW	Thru	Left	U-Turn	App Total	Peds CW	Peds CCW	Right	Left	U-Turn	App Total	Peds CW	Peds CCW
7:30:00 AM	3	34	0	37	0	0	0	0	0	0	0	0	6	0	0	6	0	0
7:45:00 AM	3	35	0	38	0	0	0	0	0	0	0	0	5	0	0	5	0	0
8:00:00 AM	4	26	0	30	0	0	0	0	0	0	0	0	3	0	0	3	1	0
8:15:00 AM	5	35	0	40	0	0	0	0	0	0	0	0	7	0	0	7	0	0
Grand Total	15	130	0	145	0	0	0	0	0	0	0	0	21	0	0	21	1	0
% Approach	10.3%	89.7%	0.0%	0.0%	0.0%	0.0%	14.2%	0.0%	0.0%	0.0%	0.0%	0.0%	45.1%	41.7%	0.0%	0.0%	0.0%	0.0%
% Total	9.0%	78.3%	0.0%	87.3%	0.0%	0.0%	0.0%	0.0%	0.0%	0.0%	0.0%	0.0%	12.7%	0.0%	0.0%	12.7%	0.0%	0.0%
PHF	0.750	0.929	0.000	0.906	0.000	0.000	0.000	0.000	0.000	0.000	0.000	0.000	0.750	0.000	0.000	0.750	0.000	0.000
Lights	12	120	0	132	0	0	0	0	0	0	0	0	19	0	0	19	0	0
% Lights	80.0%	92.3%	0.0%	91.0%	0.0%	0.0%	0.0%	0.0%	0.0%	0.0%	0.0%	0.0%	90.5%	0.0%	0.0%	90.5%	0.0%	0.0%
Trucks	0	0	0	0	0	0	0	0	0	0	0	0	0	0	0	0	0	0
% Trucks	0.0%	0.0%	0.0%	0.0%	0.0%	0.0%	0.0%	0.0%	0.0%	0.0%	0.0%	0.0%	0.0%	0.0%	0.0%	0.0%	0.0%	0.0%
Buses	3	10	0	13	0	0	0	0	0	0	0	0	2	0	0	2	0	0
% Buses	20.0%	7.7%	0.0%	0.0%	0.0%	0.0%	0.0%	0.0%	0.0%	0.0%	0.0%	0.0%	9.5%	0.0%	0.0%	0.0%	0.0%	0.0%
Pedestrians	0	0	0	0	0	0	0	0	0	0	0	0	0	0	0	0	1	0
% Pedestrians	0.0%	0.0%	0.0%	0.0%	0.0%	0.0%	0.0%	0.0%	0.0%	0.0%	0.0%	0.0%	0.0%	0.0%	0.0%	0.0%	100.0%	0.0%
Bicycles on Crosswalk	0	0	0	0	0	0	0	0	0	0	0	0	0	0	0	0	0	0
% Bicycles on Crosswalk	0.0%	0.0%	0.0%	0.0%	0.0%	0.0%	0.0%	0.0%	0.0%	0.0%	0.0%	0.0%	0.0%	0.0%	0.0%	0.0%	0.0%	0.0%

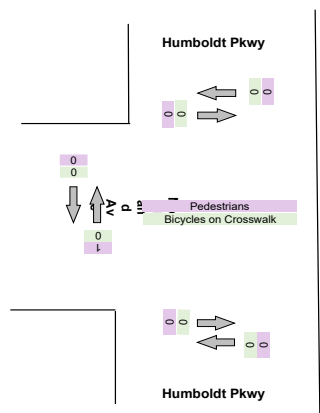
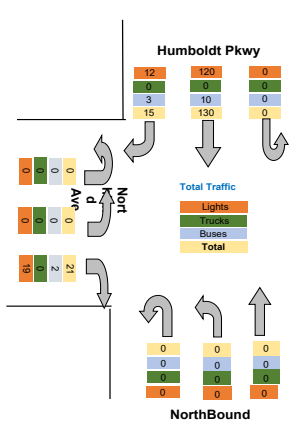

Turning Movement Peak Hour Data (PM)

4:30:00 PM

Leg Direction	Humboldt Pkwy Southbound						Humboldt Pkwy NorthBound						Northland Ave Eastbound					
	Right	Thru	U-Turn	App Total	Peds CW	Peds CCW	Thru	Left	U-Turn	App Total	Peds CW	Peds CCW	Right	Left	U-Turn	App Total	Peds CW	Peds CCW
4:30:00 PM	4	51	0	55	0	0	0	0	0	0	0	0	17	0	0	17	1	0
4:45:00 PM	3	51	0	54	0	0	0	0	0	0	0	0	11	0	0	11	1	0
5:00:00 PM	7	50	0	57	0	0	0	0	0	0	0	0	9	0	0	9	1	2
5:15:00 PM	9	41	0	50	0	0	0	0	0	0	0	0	7	0	0	7	0	0
Grand Total	23	193	0	216	0	0	0	0	0	0	0	0	44	0	0	44	3	2
% Approach	10.6%	89.4%	0.0%	0.0%	0.0%	0.0%	14.2%	0.0%	0.0%	0.0%	0.0%	0.0%	45.1%	41.7%	0.0%	0.0%	0.0%	0.0%
% Total	8.8%	74.2%	0.0%	83.1%	0.0%	0.0%	0.0%	0.0%	0.0%	0.0%	0.0%	0.0%	16.9%	0.0%	0.0%	16.9%	0.0%	0.0%
PHF	0.639	0.946	0.000	0.947	0.000	0.000	0.000	0.000	0.000	0.000	0.000	0.000	0.647	0.000	0.000	0.647	0.000	0.000
Lights	20	186	0	206	0	0	0	0	0	0	0	0	37	0	0	37	0	0
% Lights	87.0%	96.4%	0.0%	95.4%	0.0%	0.0%	0.0%	0.0%	0.0%	0.0%	0.0%	0.0%	84.1%	0.0%	0.0%	84.1%	0.0%	0.0%
Trucks	0	0	0	0	0	0	0	0	0	0	0	0	0	0	0	0	0	0
% Trucks	0.0%	0.0%	0.0%	0.0%	0.0%	0.0%	0.0%	0.0%	0.0%	0.0%	0.0%	0.0%	0.0%	0.0%	0.0%	0.0%	0.0%	0.0%
Buses	3	6	0	9	0	0	0	0	0	0	0	0	6	0	0	6	0	0
% Buses	13.0%	3.1%	0.0%	0.0%	0.0%	0.0%	0.0%	0.0%	0.0%	0.0%	0.0%	0.0%	13.6%	0.0%	0.0%	0.0%	0.0%	0.0%
Pedestrians	0	0	0	0	0	0	0	0	0	0	0	0	0	0	0	0	3	2
% Pedestrians	0.0%	0.0%	0.0%	0.0%	0.0%	0.0%	0.0%	0.0%	0.0%	0.0%	0.0%	0.0%	0.0%	0.0%	0.0%	0.0%	100.0%	100.0%
Bicycles on Crosswalk	0	0	0	0	0	0	0	0	0	0	0	0	0	0	0	0	0	0
% Bicycles on Crosswalk	0.0%	0.0%	0.0%	0.0%	0.0%	0.0%	0.0%	0.0%	0.0%	0.0%	0.0%	0.0%	0.0%	0.0%	0.0%	0.0%	0.0%	0.0%

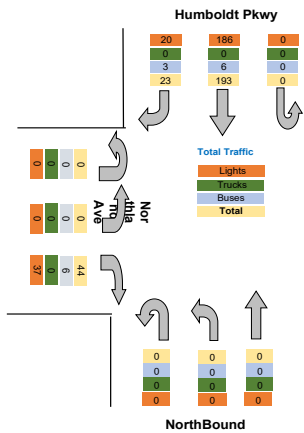

North

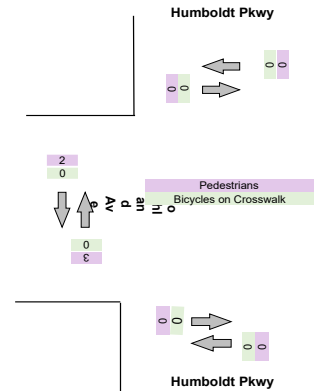

North

NorthBound

Intersection: Elm St Pine St
 Location: Kennett Square, PA
 Site: 01
 Survey Date: Wednesday, 04-28-2021
 GPS: 42.948550, -72.790034



Total
27
19
46
19
36
43
43
141
33
47
80
80
86
72
65
303
66
57
51
58
232
802
0.0%
0.0%
730
91.0%
0
0.0%
70
8.7%
0
0.0%
0.0%

Intersection: Elm St Pine St
Location: Kennett Square, PA
Site: 01
Survey Date: Wednesday, 04-28-2021
GPS: 42.948550, -72.790034

Total
43
43
33
47
166
0.883
151
91.0%
0
0.0%
15
9.0%
0
0.0%
0
0.0%

Intersection: Elm St Pine St
Location: Kennett Square, PA
Site: 01
Survey Date: Wednesday, 04-28-2021
GPS: 42.948550, -72.790034



Total
72
65
66
57
260
0.903
243
93.5%
0
0.0%
15
5.8%
0
0.0%
0
0.0%

Project	Labella
Project Code	Labella
Site Name	K
Legs and Movements	All Processed Legs & Movement
Bin Size	15 minutes
Survey Date	2021-10-28, Thursday
Location	K
Latitude and Longitude	42.919163, -78.843742

	Start	End	PHF
Forced Peak AM	2021/10/28 07:30:00	2021/10/28 08:30:00	0.939
Forced Peak PM	2021/10/28 16:30:00	2021/10/28 17:30:00	0.928
AM Peak	2021/10/28 07:30:00	2021/10/28 08:30:00	0.939
PM Peak	2021/10/28 16:30:00	2021/10/28 17:30:00	0.928

Turning Movement Data

Leg Direction	Humboldt Pkwy Southbound						Humboldt Pkwy Northbound						Northland Ave Eastbound						Total
	Right	Thru	U-Turn	App Total	Peds CW	Peds CCW	Thru	Left	U-Turn	App Total	Peds CW	Peds CCW	Right	Left	U-Turn	App Total	Peds CW	Peds CCW	
Start Time																			
6:30:00 AM	0	16	0	16	0	0	0	0	0	0	0	0	5	0	0	5	0	0	21
6:45:00 AM	1	17	0	18	0	0	0	0	0	0	0	0	3	0	0	3	0	0	42
Hourly Total	1	33	0	34	0	0	0	0	0	0	0	0	8	0	0	8	0	0	21
7:00:00 AM	3	21	0	24	0	0	0	0	0	0	0	0	2	0	0	2	0	0	26
7:15:00 AM	3	18	0	21	0	0	0	0	0	0	1	8	0	0	9	0	0	30	
7:30:00 AM	6	31	0	37	0	0	0	0	0	0	0	8	0	0	8	1	0	45	
7:45:00 AM	3	39	0	42	0	0	0	0	0	0	0	7	0	0	7	0	0	49	
Hourly Total	15	109	0	124	0	0	0	0	0	0	1	25	0	0	26	1	0	150	
8:00:00 AM	2	38	0	40	0	0	0	0	0	0	0	3	0	0	3	0	0	43	
8:15:00 AM	7	35	0	42	0	0	0	0	0	0	0	5	0	0	5	0	0	47	
Hourly Total	9	73	0	82	0	0	0	0	0	0	0	8	0	0	8	0	0	90	
4:00:00 PM	3	45	0	48	0	0	0	0	0	0	0	26	0	0	26	0	1	74	
4:15:00 PM	3	49	0	52	0	0	0	0	0	0	0	21	0	0	21	1	0	73	
4:30:00 PM	7	51	0	58	0	0	0	0	0	0	0	16	0	0	16	0	1	74	
4:45:00 PM	5	58	0	63	0	0	0	0	0	0	0	13	0	0	13	1	0	76	
Hourly Total	18	203	0	221	0	0	0	0	0	0	0	76	0	0	76	2	2	297	
5:00:00 PM	8	46	0	54	0	0	0	0	0	0	0	6	0	0	6	0	0	60	
5:15:00 PM	9	49	0	58	0	0	0	0	0	0	0	14	0	0	14	0	0	72	
5:30:00 PM	3	43	0	46	0	0	0	0	0	0	0	10	0	0	10	1	0	56	
5:45:00 PM	5	45	0	50	0	0	0	0	0	0	0	8	0	0	8	0	0	58	
Hourly Total	25	183	0	208	0	0	0	0	0	0	0	38	0	0	38	1	0	246	
Grand Total	68	601	0	669	0	0	0	0	0	0	1	155	0	0	156	4	2	825	
% Approach	10.2%	89.8%	0.0%	0.0%	0.0%	0.0%	0.0%	0.0%	0.0%	0.0%	0.0%	99.4%	0.0%	0.0%	0.0%	0.0%	0.0%	0.0%	0.0%
% Total	8.2%	72.8%	0.0%	81.1%	0.0%	0.0%	0.0%	0.0%	0.0%	0.0%	0.0%	18.8%	0.0%	0.0%	18.9%	0.0%	0.0%	0.0%	0.0%
Lights	57	566	0	623	0	0	0	0	0	0	0	131	0	0	131	0	0	754	
% Lights	83.8%	94.2%	0.0%	93.1%	0.0%	0.0%	0.0%	0.0%	0.0%	0.0%	0.0%	84.5%	0.0%	0.0%	84.0%	0.0%	0.0%	0.0%	91.4%
Trucks	0	1	0	1	0	0	0	0	0	0	0	1	0	0	1	0	0	2	
% Trucks	0.0%	0.2%	0.0%	0.1%	0.0%	0.0%	0.0%	0.0%	0.0%	0.0%	0.0%	0.6%	0.0%	0.0%	0.6%	0.0%	0.0%	0.0%	0.2%
Buses	11	32	0	43	0	0	0	0	0	0	0	23	0	0	23	0	0	66	
% Buses	16.2%	5.3%	0.0%	0.0%	0.0%	0.0%	0.0%	0.0%	0.0%	0.0%	0.0%	14.8%	0.0%	0.0%	0.0%	0.0%	0.0%	0.0%	8.0%
Pedestrians	0	0	0	0	0	0	0	0	0	0	1	0	0	0	0	3	2	0	
% Pedestrians	0.0%	0.0%	0.0%	0.0%	0.0%	0.0%	0.0%	0.0%	0.0%	0.0%	100.0%	0.0%	0.0%	0.0%	0.0%	75.0%	100.0%	0.0%	0.0%
% Bicycles on Crosswalk	0.0%	0.0%	0.0%	0.0%	0.0%	0.0%	0.0%	0.0%	0.0%	0.0%	0.0%	0.0%	0.0%	0.0%	0.0%	25.0%	0.0%	0.0%	0.0%

Turning Movement Data Plot

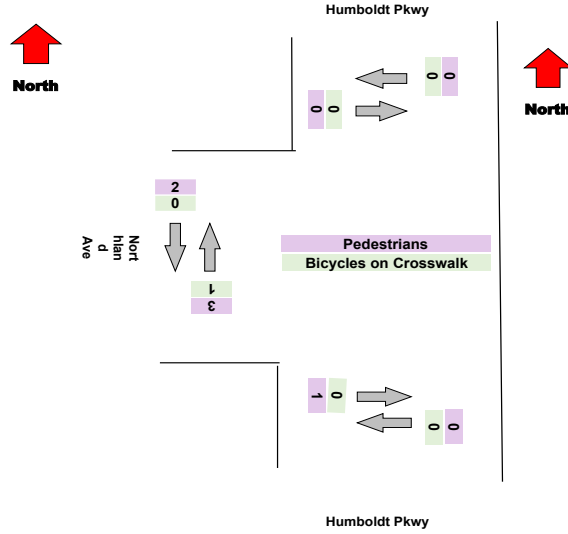
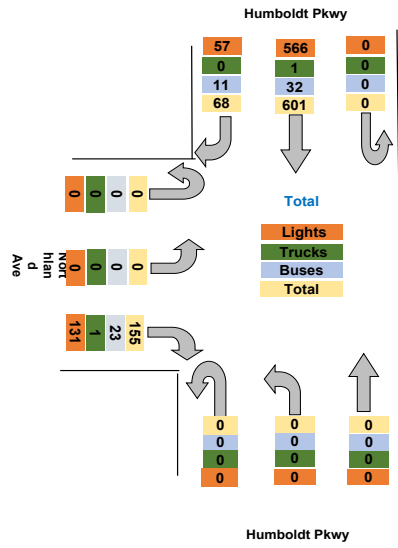

Turning Movement Peak Hour Data (AM)

7:30:00 AM

Leg Direction	Humboldt Pkwy Southbound						Humboldt Pkwy NorthBound						Northland Ave Eastbound						Total									
	Right	Thru	U-Turn	App	Total	Peds	CW	Peds	CCW	Thru	Left	U-Turn	App	Total	Peds	CW	Peds	CCW		Right	Left	U-Turn	App	Total	Peds	CW	Peds	CCW
7:30:00 AM	6	31	0	37	0	0	0	0	0	0	0	0	0	0	0	0	0	0	8	0	0	8	1	0	0	0	0	45
7:45:00 AM	3	39	0	42	0	0	0	0	0	0	0	0	0	0	0	0	0	0	7	0	0	7	0	0	0	0	49	
8:00:00 AM	2	38	0	40	0	0	0	0	0	0	0	0	0	0	0	0	0	0	3	0	0	3	0	0	0	0	43	
8:15:00 AM	7	35	0	42	0	0	0	0	0	0	0	0	0	0	0	0	0	0	5	0	0	5	0	0	0	0	47	
Grand Total	18	143	0	161	0	0	0	0	0	0	0	0	0	0	0	0	0	23	0	0	23	1	0	0	0	184		
% Approach	11.2%	88.8%	0.0%	0.0%	0.0%	0.0%	0.0%	0.0%	0.0%	14.2%	0.0%	0.0%	0.0%	0.0%	0.0%	0.0%	0.0%	45.1%	41.7%	0.0%	0.0%	0.0%	0.0%	0.0%	0.0%	0.0%	0.0%	
% Total	9.8%	77.7%	0.0%	87.5%	0.0%	0.0%	0.0%	0.0%	0.0%	0.0%	0.0%	0.0%	0.0%	0.0%	0.0%	0.0%	0.0%	12.5%	0.0%	0.0%	12.5%	0.0%	0.0%	0.0%	0.0%	0.0%		
PHF	0.643	0.917	0.000	0.958	0.000	0.000	0.000	0.000	0.000	0.000	0.000	0.000	0.000	0.000	0.000	0.000	0.000	0.719	0.000	0.000	0.719	0.000	0.000	0.000	0.000	0.939		
Lights	16	135	0	151	0	0	0	0	0	0	0	0	0	0	0	0	0	21	0	0	21	0	0	0	0	172		
% Lights	88.9%	94.4%	0.0%	93.8%	0.0%	0.0%	0.0%	0.0%	0.0%	0.0%	0.0%	0.0%	0.0%	0.0%	0.0%	0.0%	0.0%	91.3%	0.0%	0.0%	91.3%	0.0%	0.0%	0.0%	0.0%	93.5%		
Trucks	0	1	0	1	0	0	0	0	0	0	0	0	0	0	0	0	0	0	0	0	0	0	0	0	0	0	1	
% Trucks	0.0%	0.7%	0.0%	0.6%	0.0%	0.0%	0.0%	0.0%	0.0%	0.0%	0.0%	0.0%	0.0%	0.0%	0.0%	0.0%	0.0%	0.0%	0.0%	0.0%	0.0%	0.0%	0.0%	0.0%	0.0%	0.5%		
Buses	2	7	0	9	0	0	0	0	0	0	0	0	0	0	0	0	0	2	0	0	2	0	0	0	0	11		
% Buses	11.1%	4.9%	0.0%	0.0%	0.0%	0.0%	0.0%	0.0%	0.0%	0.0%	0.0%	0.0%	0.0%	0.0%	0.0%	0.0%	0.0%	8.7%	0.0%	0.0%	0.0%	0.0%	0.0%	0.0%	0.0%	6.0%		
Pedestrians	0	0	0	0	0	0	0	0	0	0	0	0	0	0	0	0	0	0	0	0	0	0	1	0	0	0		
% Pedestrians	0.0%	0.0%	0.0%	0.0%	0.0%	0.0%	0.0%	0.0%	0.0%	0.0%	0.0%	0.0%	0.0%	0.0%	0.0%	0.0%	0.0%	0.0%	0.0%	0.0%	0.0%	100.0%	0.0%	0.0%	0.0%	0.0%		
Bicycles on Crosswalk	0	0	0	0	0	0	0	0	0	0	0	0	0	0	0	0	0	0	0	0	0	0	0	0	0	0	0	
% Bicycles on Crosswalk	0.0%	0.0%	0.0%	0.0%	0.0%	0.0%	0.0%	0.0%	0.0%	0.0%	0.0%	0.0%	0.0%	0.0%	0.0%	0.0%	0.0%	0.0%	0.0%	0.0%	0.0%	0.0%	0.0%	0.0%	0.0%	0.0%		

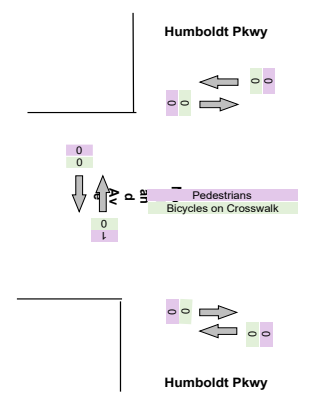
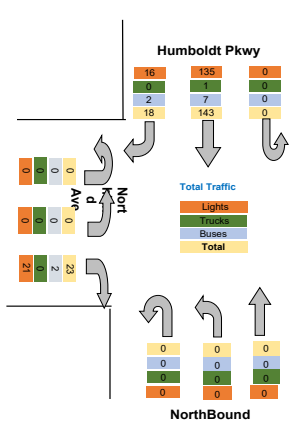

Turning Movement Peak Hour Data (PM)

4:30:00 PM

Leg Direction	Humboldt Pkwy Southbound						Humboldt Pkwy NorthBound						Northland Ave Eastbound						Total
	Right	Thru	U-Turn	App Total	Peds CW	Peds CCW	Thru	Left	U-Turn	App Total	Peds CW	Peds CCW	Right	Left	U-Turn	App Total	Peds CW	Peds CCW	
4:30:00 PM	7	51	0	58	0	0	0	0	0	0	0	0	16	0	0	16	0	1	74
4:45:00 PM	5	58	0	63	0	0	0	0	0	0	0	0	13	0	0	13	1	0	76
5:00:00 PM	8	46	0	54	0	0	0	0	0	0	0	0	6	0	0	6	0	0	60
5:15:00 PM	9	49	0	58	0	0	0	0	0	0	0	0	14	0	0	14	0	0	72
Grand Total	29	204	0	233	0	0	0	0	0	0	0	0	49	0	0	49	1	1	282
% Approach	12.4%	87.6%	0.0%	0.0%	0.0%	0.0%	14.2%	0.0%	0.0%	0.0%	0.0%	0.0%	45.1%	41.7%	0.0%	0.0%	0.0%	0.0%	0.0%
% Total	10.3%	72.3%	0.0%	82.6%	0.0%	0.0%	0.0%	0.0%	0.0%	0.0%	0.0%	0.0%	17.4%	0.0%	0.0%	17.4%	0.0%	0.0%	0.0%
PHF	0.806	0.879	0.000	0.925	0.000	0.000	0.000	0.000	0.000	0.000	0.000	0.000	0.766	0.000	0.000	0.766	0.000	0.000	0.928
Lights	27	196	0	223	0	0	0	0	0	0	0	0	40	0	0	40	0	0	263
% Lights	93.1%	96.1%	0.0%	95.7%	0.0%	0.0%	0.0%	0.0%	0.0%	0.0%	0.0%	0.0%	81.6%	0.0%	0.0%	81.6%	0.0%	0.0%	93.3%
Trucks	0	0	0	0	0	0	0	0	0	0	0	0	1	0	0	1	0	0	1
% Trucks	0.0%	0.0%	0.0%	0.0%	0.0%	0.0%	0.0%	0.0%	0.0%	0.0%	0.0%	0.0%	2.0%	0.0%	0.0%	2.0%	0.0%	0.0%	0.4%
Buses	2	6	0	8	0	0	0	0	0	0	0	0	8	0	0	8	0	0	16
% Buses	6.9%	2.9%	0.0%	0.0%	0.0%	0.0%	0.0%	0.0%	0.0%	0.0%	0.0%	0.0%	16.3%	0.0%	0.0%	0.0%	0.0%	0.0%	5.7%
Pedestrians	0	0	0	0	0	0	0	0	0	0	0	0	0	0	0	0	1	1	0
% Pedestrians	0.0%	0.0%	0.0%	0.0%	0.0%	0.0%	0.0%	0.0%	0.0%	0.0%	0.0%	0.0%	0.0%	0.0%	0.0%	0.0%	100.0%	100.0%	0.0%
Bicycles on Crosswalk	0	0	0	0	0	0	0	0	0	0	0	0	0	0	0	0	0	0	0
% Bicycles on Crosswalk	0.0%	0.0%	0.0%	0.0%	0.0%	0.0%	0.0%	0.0%	0.0%	0.0%	0.0%	0.0%	0.0%	0.0%	0.0%	0.0%	0.0%	0.0%	0.0%

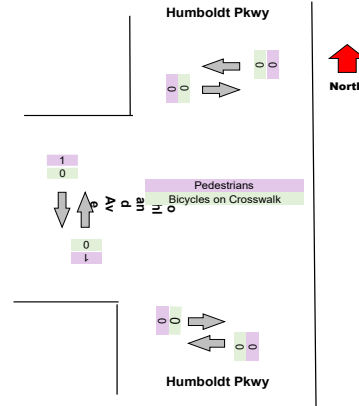
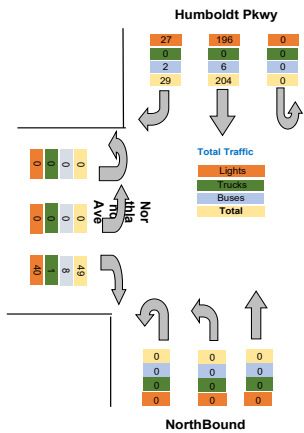

Turning Movement Data Plot

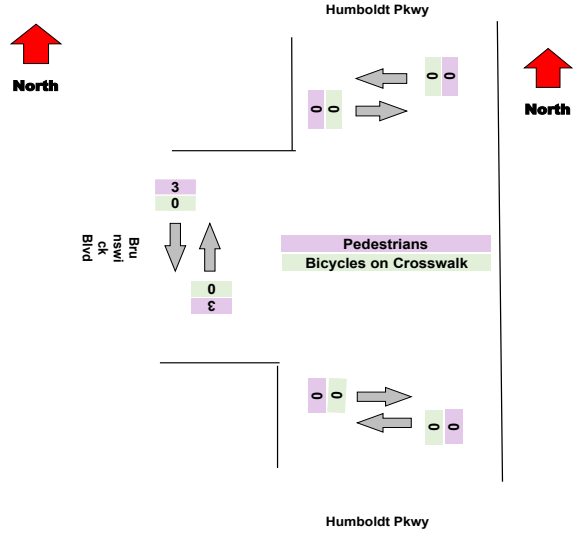
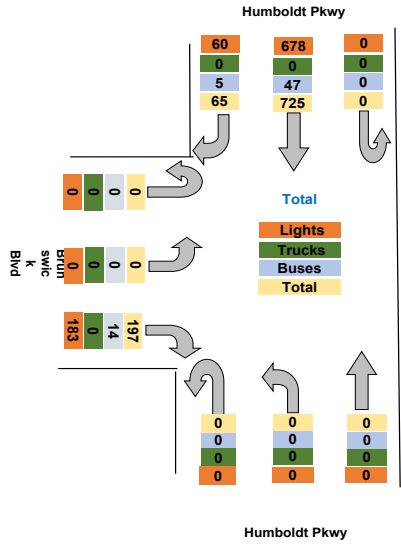

Turning Movement Peak Hour Data (AM)

7:30:00 AM

Leg Direction	Humboldt Pkwy Southbound						Humboldt Pkwy NorthBound						Brunswick Blvd Eastbound						Total				
	Right	Thru	U-Turn	App	Total	Peds CW	Peds CCW	Thru	Left	U-Turn	App	Total	Peds CW	Peds CCW	Right	Left	U-Turn	App		Total	Peds CW	Peds CCW	
7:30:00 AM	3	48	0	51	0	0	0	0	0	0	0	0	0	0	13	0	0	13	0	0	0	0	64
7:45:00 AM	1	42	0	43	0	0	0	0	0	0	0	0	0	0	13	0	0	13	1	0	0	0	56
8:00:00 AM	6	30	0	36	0	0	0	0	0	0	0	0	0	0	10	0	0	10	0	0	0	0	46
8:15:00 AM	4	41	0	45	0	0	0	0	0	0	0	0	0	0	19	0	0	19	0	0	0	0	64
Grand Total	14	161	0	175	0	0	0	0	0	0	0	0	0	0	55	0	0	55	1	0	0	0	230
% Approach	8.0%	92.0%	0.0%	0.0%	0.0%	0.0%	14.2%	0.0%	0.0%	0.0%	0.0%	0.0%	0.0%	0.0%	45.1%	41.7%	0.0%	0.0%	0.0%	0.0%	0.0%	0.0%	0.0%
% Total	6.1%	70.0%	0.0%	76.1%	0.0%	0.0%	0.0%	0.0%	0.0%	0.0%	0.0%	0.0%	0.0%	0.0%	23.9%	0.0%	0.0%	23.9%	0.0%	0.0%	0.0%	0.0%	0.0%
PHF	0.583	0.839	0.000	0.858	0.000	0.000	0.000	0.000	0.000	0.000	0.000	0.000	0.000	0.000	0.724	0.000	0.000	0.724	0.000	0.000	0.000	0.000	0.898
Lights	13	151	0	164	0	0	0	0	0	0	0	0	0	0	51	0	0	51	0	0	0	0	215
% Lights	92.9%	93.8%	0.0%	93.7%	0.0%	0.0%	0.0%	0.0%	0.0%	0.0%	0.0%	0.0%	0.0%	0.0%	92.7%	0.0%	0.0%	92.7%	0.0%	0.0%	0.0%	0.0%	93.5%
Trucks	0	0	0	0	0	0	0	0	0	0	0	0	0	0	0	0	0	0	0	0	0	0	0
% Trucks	0.0%	0.0%	0.0%	0.0%	0.0%	0.0%	0.0%	0.0%	0.0%	0.0%	0.0%	0.0%	0.0%	0.0%	0.0%	0.0%	0.0%	0.0%	0.0%	0.0%	0.0%	0.0%	0.0%
Buses	1	10	0	11	0	0	0	0	0	0	0	0	0	0	4	0	0	4	0	0	0	0	15
% Buses	7.1%	6.2%	0.0%	6.3%	0.0%	0.0%	0.0%	0.0%	0.0%	0.0%	0.0%	0.0%	0.0%	0.0%	7.3%	0.0%	0.0%	7.3%	0.0%	0.0%	0.0%	0.0%	6.5%
Pedestrians	0	0	0	0	0	0	0	0	0	0	0	0	0	0	0	0	0	0	0	1	0	0	0
% Pedestrians	0.0%	0.0%	0.0%	0.0%	0.0%	0.0%	0.0%	0.0%	0.0%	0.0%	0.0%	0.0%	0.0%	0.0%	0.0%	0.0%	0.0%	0.0%	0.0%	100.0%	0.0%	0.0%	0.0%
Bicycles on Crosswalk	0	0	0	0	0	0	0	0	0	0	0	0	0	0	0	0	0	0	0	0	0	0	0
% Bicycles on Crosswalk	0.0%	0.0%	0.0%	0.0%	0.0%	0.0%	0.0%	0.0%	0.0%	0.0%	0.0%	0.0%	0.0%	0.0%	0.0%	0.0%	0.0%	0.0%	0.0%	0.0%	0.0%	0.0%	0.0%

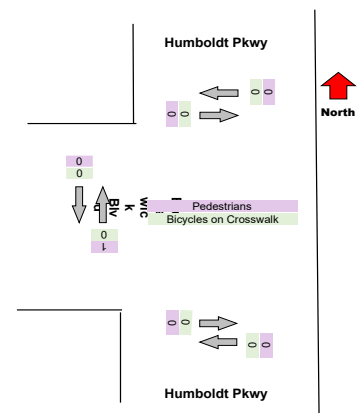
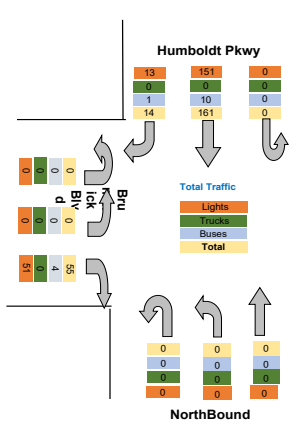

Turning Movement Peak Hour Data (PM)

4:30:00 PM

Leg Direction	Humboldt Pkwy Southbound						Humboldt Pkwy NorthBound						Brunswick Blvd Eastbound						Total
	Right	Thru	U-Turn	App Total	Peds CW	Peds CCW	Thru	Left	U-Turn	App Total	Peds CW	Peds CCW	Right	Left	U-Turn	App Total	Peds CW	Peds CCW	
4:30:00 PM	8	59	0	67	0	0	0	0	0	0	0	0	16	0	0	16	0	0	83
4:45:00 PM	9	53	0	62	0	0	0	0	0	0	0	0	16	0	0	16	0	1	78
5:00:00 PM	6	57	0	63	0	0	0	0	0	0	0	0	10	0	0	10	0	0	73
5:15:00 PM	7	44	0	51	0	0	0	0	0	0	0	0	15	0	0	15	0	0	66
Grand Total	30	213	0	243	0	0	0	0	0	0	0	0	57	0	0	57	0	1	300
% Approach	12.3%	87.7%	0.0%	0.0%	0.0%	0.0%	14.2%	0.0%	0.0%	0.0%	0.0%	0.0%	45.1%	41.7%	0.0%	0.0%	0.0%	0.0%	0.0%
% Total	10.0%	71.0%	0.0%	81.0%	0.0%	0.0%	0.0%	0.0%	0.0%	0.0%	0.0%	0.0%	19.0%	0.0%	0.0%	19.0%	0.0%	0.0%	0.0%
PHF	0.833	0.903	0.000	0.907	0.000	0.000	0.000	0.000	0.000	0.000	0.000	0.000	0.891	0.000	0.000	0.891	0.000	0.000	0.904
Lights	28	200	0	228	0	0	0	0	0	0	0	0	52	0	0	52	0	0	280
% Lights	93.3%	93.9%	0.0%	93.8%	0.0%	0.0%	0.0%	0.0%	0.0%	0.0%	0.0%	0.0%	91.2%	0.0%	0.0%	91.2%	0.0%	0.0%	93.3%
Trucks	0	0	0	0	0	0	0	0	0	0	0	0	0	0	0	0	0	0	0
% Trucks	0.0%	0.0%	0.0%	0.0%	0.0%	0.0%	0.0%	0.0%	0.0%	0.0%	0.0%	0.0%	0.0%	0.0%	0.0%	0.0%	0.0%	0.0%	0.0%
Buses	2	13	0	15	0	0	0	0	0	0	0	0	5	0	0	5	0	0	20
% Buses	6.7%	6.1%	0.0%	6.2%	0.0%	0.0%	0.0%	0.0%	0.0%	0.0%	0.0%	0.0%	8.8%	0.0%	0.0%	8.8%	0.0%	0.0%	6.7%
Pedestrians	0	0	0	0	0	0	0	0	0	0	0	0	0	0	0	0	0	1	0
% Pedestrians	0.0%	0.0%	0.0%	0.0%	0.0%	0.0%	0.0%	0.0%	0.0%	0.0%	0.0%	0.0%	0.0%	0.0%	0.0%	0.0%	0.0%	100.0%	0.0%
Bicycles on Crosswalk	0	0	0	0	0	0	0	0	0	0	0	0	0	0	0	0	0	0	0
% Bicycles on Crosswalk	0.0%	0.0%	0.0%	0.0%	0.0%	0.0%	0.0%	0.0%	0.0%	0.0%	0.0%	0.0%	0.0%	0.0%	0.0%	0.0%	0.0%	0.0%	0.0%

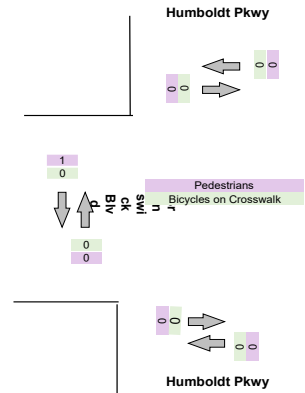
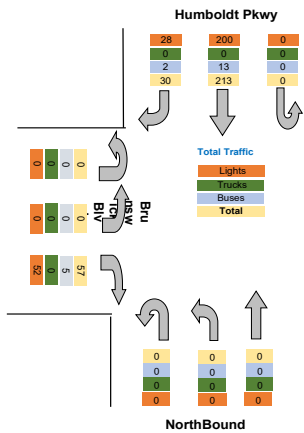

Project	Labella
Project Code	Labella
Site Name	L
Legs and Movements	All Processed Legs & Movement
Bin Size	15 minutes
Survey Date	2021-10-27, Wednesday
Location	L
Latitude and Longitude	42.916951, -78.843751

	Start	End	PHF
Forced Peak AM	2021/10/27 07:30:00	2021/10/27 08:30:00	0.904
Forced Peak PM	2021/10/27 16:30:00	2021/10/27 17:30:00	0.824
AM Peak	2021/10/27 07:30:00	2021/10/27 08:30:00	0.904
PM Peak	2021/10/27 16:30:00	2021/10/27 17:30:00	0.824

Turning Movement Data

Leg Direction	Humboldt Pkwy Southbound						Humboldt Pkwy Northbound						Brunswick Blvd Eastbound					
	Right	Thru	U-Turn	App Total	Peds CW	Peds CCW	Thru	Left	U-Turn	App Total	Peds CW	Peds CCW	Right	Left	U-Turn	App Total	Peds CW	Peds CCW
6:30:00 AM	1	27	0	28	0	0	0	0	0	0	0	0	6	0	0	6	0	1
6:45:00 AM	0	22	0	22	0	0	0	0	0	0	0	0	7	0	0	7	0	0
Hourly Total	1	49	0	50	0	0	0	0	0	0	0	0	13	0	0	13	0	1
7:00:00 AM	2	10	0	12	0	0	0	0	0	0	0	0	4	0	0	4	0	0
7:15:00 AM	3	34	0	37	0	0	0	0	0	0	0	0	13	0	0	13	0	0
7:30:00 AM	2	39	0	41	0	0	0	0	0	0	0	0	20	0	0	20	0	0
7:45:00 AM	3	42	0	45	0	0	0	0	0	0	0	0	20	0	0	20	0	0
Hourly Total	10	125	0	135	0	0	0	0	0	0	0	0	57	0	0	57	0	0
8:00:00 AM	2	35	0	37	0	0	0	0	0	0	0	0	14	0	0	14	0	0
8:15:00 AM	5	40	0	45	0	0	0	0	0	0	0	0	13	0	0	13	0	0
Hourly Total	7	75	0	82	0	0	0	0	0	0	0	0	27	0	0	27	0	0
4:00:00 PM	3	75	0	78	0	0	0	0	0	0	0	0	12	0	0	12	0	0
4:15:00 PM	5	67	0	72	0	0	0	0	0	0	0	0	10	0	0	10	2	0
4:30:00 PM	4	67	0	71	0	0	0	0	0	0	0	0	20	0	0	20	1	0
4:45:00 PM	3	51	0	54	0	0	0	0	0	0	0	0	17	0	0	17	0	0
Hourly Total	15	260	0	275	0	0	0	0	0	0	0	0	59	0	0	59	3	0
5:00:00 PM	7	50	0	57	0	0	0	0	0	0	0	0	14	0	0	14	1	1
5:15:00 PM	6	44	0	50	0	0	0	0	0	0	0	0	17	0	0	17	1	0
5:30:00 PM	4	46	0	50	0	0	0	0	0	0	0	0	13	0	0	13	0	0
5:45:00 PM	6	43	0	49	0	0	0	0	0	0	0	0	16	0	0	16	0	0
Hourly Total	23	183	0	206	0	0	0	0	0	0	0	0	60	0	0	60	2	1
Grand Total	56	692	0	748	0	0	0	0	0	0	0	0	216	0	0	216	5	2
% Approach	7.5%	92.5%	0.0%	0.0%	0.0%	0.0%	0.0%	0.0%	0.0%	0.0%	0.0%	0.0%	100.0%	0.0%	0.0%	0.0%	0.0%	0.0%
% Total	5.8%	71.8%	0.0%	77.6%	0.0%	0.0%	0.0%	0.0%	0.0%	0.0%	0.0%	0.0%	22.4%	0.0%	0.0%	22.4%	0.0%	0.0%
Lights	47	649	0	696	0	0	0	0	0	0	0	0	201	0	0	201	0	0
% Lights	83.9%	93.8%	0.0%	93.0%	0.0%	0.0%	0.0%	0.0%	0.0%	0.0%	0.0%	0.0%	93.1%	0.0%	0.0%	93.1%	0.0%	0.0%
Trucks	0	0	0	0	0	0	0	0	0	0	0	0	1	0	0	1	0	0
% Trucks	0.0%	0.0%	0.0%	0.0%	0.0%	0.0%	0.0%	0.0%	0.0%	0.0%	0.0%	0.0%	0.5%	0.0%	0.0%	0.5%	0.0%	0.0%
Buses	9	42	0	51	0	0	0	0	0	0	0	0	14	0	0	14	0	0
% Buses	16.1%	6.1%	0.0%	0.0%	0.0%	0.0%	0.0%	0.0%	0.0%	0.0%	0.0%	0.0%	6.5%	0.0%	0.0%	0.0%	0.0%	0.0%
Pedestrians	0	0	0	0	0	0	0	0	0	0	0	0	0	0	0	0	4	2
% Pedestrians	0.0%	0.0%	0.0%	0.0%	0.0%	0.0%	0.0%	0.0%	0.0%	0.0%	0.0%	0.0%	0.0%	0.0%	0.0%	0.0%	80.0%	100.0%
% Bicycles on Crosswalk	0.0%	0.0%	0.0%	0.0%	0.0%	0.0%	0.0%	0.0%	0.0%	0.0%	0.0%	0.0%	0.0%	0.0%	0.0%	0.0%	20.0%	0.0%

Turning Movement Data Plot

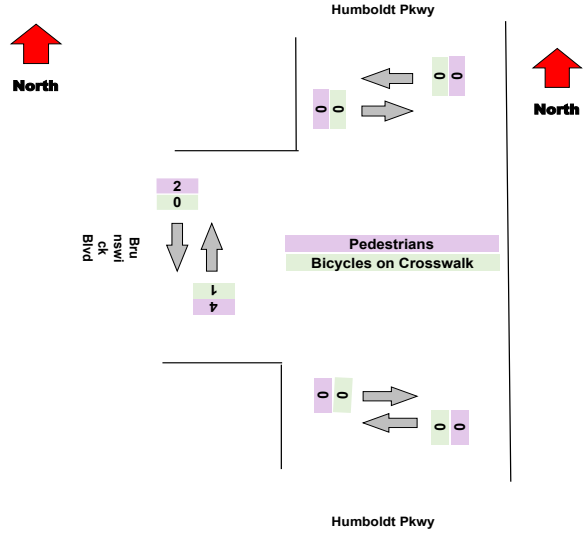
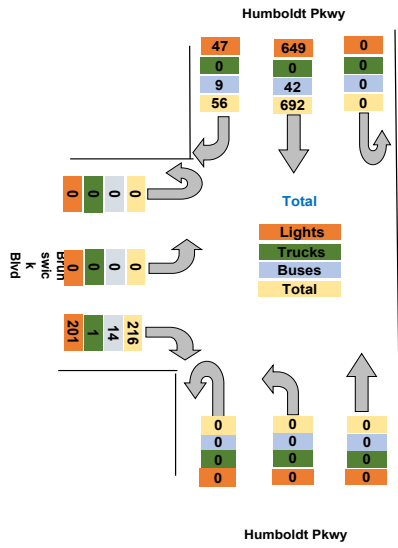

Turning Movement Peak Hour Data (AM)

7:30:00 AM

Leg Direction	Humboldt Pkwy Southbound						Humboldt Pkwy NorthBound						Brunswick Blvd Eastbound					
	Right	Thru	U-Turn	App Total	Peds CW	Peds CCW	Thru	Left	U-Turn	App Total	Peds CW	Peds CCW	Right	Left	U-Turn	App Total	Peds CW	Peds CCW
7:30:00 AM	2	39	0	41	0	0	0	0	0	0	0	0	20	0	0	20	0	0
7:45:00 AM	3	42	0	45	0	0	0	0	0	0	0	0	20	0	0	20	0	0
8:00:00 AM	2	35	0	37	0	0	0	0	0	0	0	0	14	0	0	14	0	0
8:15:00 AM	5	40	0	45	0	0	0	0	0	0	0	0	13	0	0	13	0	0
Grand Total	12	156	0	168	0	0	0	0	0	0	0	0	67	0	0	67	0	0
% Approach	7.1%	92.9%	0.0%	0.0%	0.0%	0.0%	14.2%	0.0%	0.0%	0.0%	0.0%	0.0%	45.1%	41.7%	0.0%	0.0%	0.0%	0.0%
% Total	5.1%	66.4%	0.0%	71.5%	0.0%	0.0%	0.0%	0.0%	0.0%	0.0%	0.0%	0.0%	28.5%	0.0%	0.0%	28.5%	0.0%	0.0%
PHF	0.600	0.929	0.000	0.933	0.000	0.000	0.000	0.000	0.000	0.000	0.000	0.000	0.838	0.000	0.000	0.838	0.000	0.000
Lights	10	147	0	157	0	0	0	0	0	0	0	0	58	0	0	58	0	0
% Lights	83.3%	94.2%	0.0%	93.5%	0.0%	0.0%	0.0%	0.0%	0.0%	0.0%	0.0%	0.0%	86.6%	0.0%	0.0%	86.6%	0.0%	0.0%
Trucks	0	0	0	0	0	0	0	0	0	0	0	0	1	0	0	1	0	0
% Trucks	0.0%	0.0%	0.0%	0.0%	0.0%	0.0%	0.0%	0.0%	0.0%	0.0%	0.0%	0.0%	1.5%	0.0%	0.0%	1.5%	0.0%	0.0%
Buses	2	9	0	11	0	0	0	0	0	0	0	0	8	0	0	8	0	0
% Buses	16.7%	5.8%	0.0%	0.0%	0.0%	0.0%	0.0%	0.0%	0.0%	0.0%	0.0%	0.0%	11.9%	0.0%	0.0%	0.0%	0.0%	0.0%
Pedestrians	0	0	0	0	0	0	0	0	0	0	0	0	0	0	0	0	0	0
% Pedestrians	0.0%	0.0%	0.0%	0.0%	0.0%	0.0%	0.0%	0.0%	0.0%	0.0%	0.0%	0.0%	0.0%	0.0%	0.0%	0.0%	0.0%	0.0%
Bicycles on Crosswalk	0	0	0	0	0	0	0	0	0	0	0	0	0	0	0	0	0	0
% Bicycles on Crosswalk	0.0%	0.0%	0.0%	0.0%	0.0%	0.0%	0.0%	0.0%	0.0%	0.0%	0.0%	0.0%	0.0%	0.0%	0.0%	0.0%	0.0%	0.0%

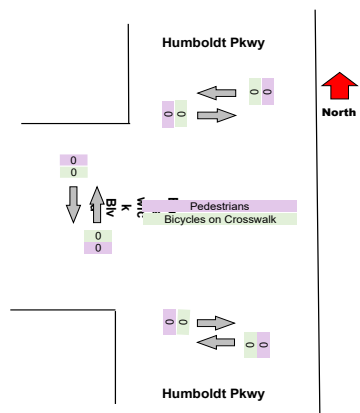
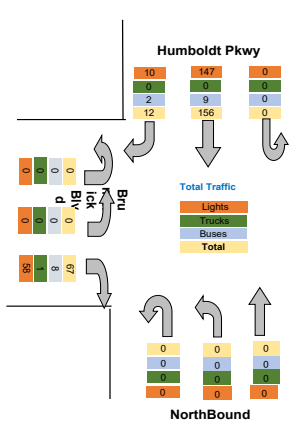

Turning Movement Peak Hour Data (PM)

4:30:00 PM

Leg Direction	Humboldt Pkwy Southbound						Humboldt Pkwy NorthBound						Brunswick Blvd Eastbound					
	Right	Thru	U-Turn	App Total	Peds CW	Peds CCW	Thru	Left	U-Turn	App Total	Peds CW	Peds CCW	Right	Left	U-Turn	App Total	Peds CW	Peds CCW
4:30:00 PM	4	67	0	71	0	0	0	0	0	0	0	0	20	0	0	20	1	0
4:45:00 PM	3	51	0	54	0	0	0	0	0	0	0	0	17	0	0	17	0	0
5:00:00 PM	7	50	0	57	0	0	0	0	0	0	0	0	14	0	0	14	1	1
5:15:00 PM	6	44	0	50	0	0	0	0	0	0	0	0	17	0	0	17	1	0
Grand Total	20	212	0	232	0	0	0	0	0	0	0	0	68	0	0	68	3	1
% Approach	8.6%	91.4%	0.0%	0.0%	0.0%	0.0%	14.2%	0.0%	0.0%	0.0%	0.0%	0.0%	45.1%	41.7%	0.0%	0.0%	0.0%	0.0%
% Total	6.7%	70.7%	0.0%	77.3%	0.0%	0.0%	0.0%	0.0%	0.0%	0.0%	0.0%	0.0%	22.7%	0.0%	0.0%	22.7%	0.0%	0.0%
PHF	0.714	0.791	0.000	0.817	0.000	0.000	0.000	0.000	0.000	0.000	0.000	0.000	0.850	0.000	0.000	0.850	0.000	0.000
Lights	16	200	0	216	0	0	0	0	0	0	0	0	68	0	0	66	0	0
% Lights	80.0%	94.3%	0.0%	93.1%	0.0%	0.0%	0.0%	0.0%	0.0%	0.0%	0.0%	0.0%	97.1%	0.0%	0.0%	97.1%	0.0%	0.0%
Trucks	0	0	0	0	0	0	0	0	0	0	0	0	0	0	0	0	0	0
% Trucks	0.0%	0.0%	0.0%	0.0%	0.0%	0.0%	0.0%	0.0%	0.0%	0.0%	0.0%	0.0%	0.0%	0.0%	0.0%	0.0%	0.0%	0.0%
Buses	4	11	0	15	0	0	0	0	0	0	0	0	2	0	0	2	0	0
% Buses	20.0%	5.2%	0.0%	0.0%	0.0%	0.0%	0.0%	0.0%	0.0%	0.0%	0.0%	0.0%	2.9%	0.0%	0.0%	0.0%	0.0%	0.0%
Pedestrians	0	0	0	0	0	0	0	0	0	0	0	0	0	0	0	0	2	1
% Pedestrians	0.0%	0.0%	0.0%	0.0%	0.0%	0.0%	0.0%	0.0%	0.0%	0.0%	0.0%	0.0%	0.0%	0.0%	0.0%	0.0%	66.7%	100.0%
Bicycles on Crosswalk	0	0	0	0	0	0	0	0	0	0	0	0	0	0	0	0	1	0
% Bicycles on Crosswalk	0.0%	0.0%	0.0%	0.0%	0.0%	0.0%	0.0%	0.0%	0.0%	0.0%	0.0%	0.0%	0.0%	0.0%	0.0%	0.0%	33.3%	0.0%

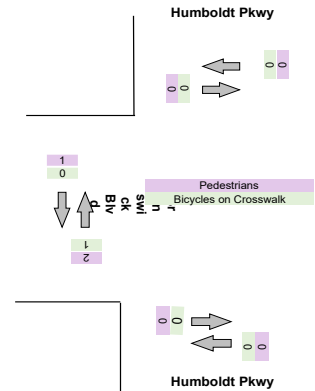
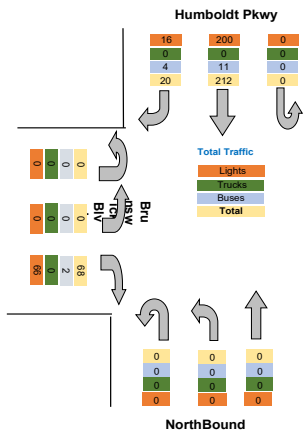

Intersection: Elm St Pine St
 Location: Kennett Square, PA
 Site: 01
 Survey Date: Wednesday, 04-28-2021
 GPS: 42.948550, -72.790034



Total
34
29
63
16
50
61
65
192
51
58
109
90
82
91
71
334
71
67
63
65
266
964
0.0%
0.0%
897
93.0%
1
0.1%
65
6.7%
0
0.0%
0.0%

Intersection: Elm St Pine St
Location: Kennett Square, PA
Site: 01
Survey Date: Wednesday, 04-28-2021
GPS: 42.948550, -72.790034

Total
61
65
51
58
235
0.904
215
91.5%
1
0.4%
19
8.1%
0
0.0%
0
0.0%

Intersection: Elm St Pine St
Location: Kennett Square, PA
Site: 01
Survey Date: Wednesday, 04-28-2021
GPS: 42.948550, -72.790034



Total
91
71
71
67
300
0.824
282
94.0%
0
0.0%
17
5.7%
0
0.0%
0
0.0%

Project	Labella
Project Code	Labella
Site Name	L
Legs and Movements	All Processed Legs & Movement
Bin Size	15 minutes
Survey Date	2021-10-28, Thursday
Location	L
Latitude and Longitude	42.916951, -78.843751

	Start	End	PHF
Forced Peak AM	2021/10/28 07:30:00	2021/10/28 08:30:00	0.843
Forced Peak PM	2021/10/28 16:30:00	2021/10/28 17:30:00	0.893
AM Peak	2021/10/28 07:30:00	2021/10/28 08:30:00	0.843
PM Peak	2021/10/28 16:30:00	2021/10/28 17:30:00	0.893

Turning Movement Data

Leg Direction	Humboldt Pkwy Southbound						Humboldt Pkwy Northbound						Brunswick Blvd Eastbound					
	Right	Thru	U-Turn	App Total	Peds CW	Peds CCW	Thru	Left	U-Turn	App Total	Peds CW	Peds CCW	Right	Left	U-Turn	App Total	Peds CW	Peds CCW
6:30:00 AM	0	20	0	20	0	0	0	0	0	0	0	0	4	0	0	4	0	0
6:45:00 AM	2	19	0	21	0	0	0	0	0	0	0	0	5	0	0	5	0	0
Hourly Total	2	39	0	41	0	0	0	0	0	0	0	0	9	0	0	9	0	0
7:00:00 AM	2	21	0	23	0	0	0	0	0	0	0	0	7	0	0	7	0	0
7:15:00 AM	3	25	0	28	0	0	0	0	0	0	0	0	11	0	0	11	0	0
7:30:00 AM	1	43	0	44	0	0	0	0	0	0	0	0	15	0	0	15	0	0
7:45:00 AM	2	52	0	54	0	0	0	0	0	0	0	0	16	0	0	16	2	0
Hourly Total	8	141	0	149	0	0	0	0	0	0	0	0	49	0	0	49	2	0
8:00:00 AM	4	39	0	43	0	0	0	0	0	0	0	0	8	0	0	8	0	0
8:15:00 AM	3	36	0	39	0	0	0	0	0	0	0	0	17	0	0	17	0	0
Hourly Total	7	75	0	82	0	0	0	0	0	0	0	0	25	0	0	25	0	0
4:00:00 PM	6	70	0	76	0	0	0	0	0	0	0	0	14	0	0	14	0	0
4:15:00 PM	4	66	0	70	0	0	0	0	0	0	0	0	12	0	0	12	1	1
4:30:00 PM	7	66	0	73	0	0	0	0	0	0	0	0	10	0	0	10	0	0
4:45:00 PM	7	63	0	70	0	0	0	0	0	0	0	0	21	0	0	21	1	1
Hourly Total	24	265	0	289	0	0	0	0	0	0	0	0	57	0	0	57	2	2
5:00:00 PM	3	54	0	57	0	0	0	0	0	0	0	0	20	0	0	20	0	1
5:15:00 PM	7	55	0	62	0	0	0	0	0	0	0	0	12	0	0	12	0	0
5:30:00 PM	2	51	0	53	0	0	0	0	0	0	0	0	14	0	0	14	1	0
5:45:00 PM	4	54	0	58	0	0	0	0	0	0	0	0	25	0	0	25	1	2
Hourly Total	16	214	0	230	0	0	0	0	0	0	0	0	71	0	0	71	2	3
Grand Total	57	734	0	791	0	0	0	0	0	0	0	0	211	0	0	211	6	5
% Approach	7.2%	92.8%	0.0%	0.0%	0.0%	0.0%	0.0%	0.0%	0.0%	0.0%	0.0%	0.0%	100.0%	0.0%	0.0%	0.0%	0.0%	0.0%
% Total	5.7%	73.3%	0.0%	78.9%	0.0%	0.0%	0.0%	0.0%	0.0%	0.0%	0.0%	0.0%	21.1%	0.0%	0.0%	21.1%	0.0%	0.0%
Lights	52	681	0	733	0	0	0	0	0	0	0	0	199	0	0	199	0	0
% Lights	91.2%	92.8%	0.0%	92.7%	0.0%	0.0%	0.0%	0.0%	0.0%	0.0%	0.0%	0.0%	94.3%	0.0%	0.0%	94.3%	0.0%	0.0%
Trucks	0	2	0	2	0	0	0	0	0	0	0	0	0	0	0	0	0	0
% Trucks	0.0%	0.3%	0.0%	0.3%	0.0%	0.0%	0.0%	0.0%	0.0%	0.0%	0.0%	0.0%	0.0%	0.0%	0.0%	0.0%	0.0%	0.0%
Buses	5	49	0	54	0	0	0	0	0	0	0	0	12	0	0	12	0	0
% Buses	8.8%	6.7%	0.0%	0.0%	0.0%	0.0%	0.0%	0.0%	0.0%	0.0%	0.0%	0.0%	5.7%	0.0%	0.0%	0.0%	0.0%	0.0%
Pedestrians	0	0	0	0	0	0	0	0	0	0	0	0	0	0	0	0	3	4
% Pedestrians	0.0%	0.0%	0.0%	0.0%	0.0%	0.0%	0.0%	0.0%	0.0%	0.0%	0.0%	0.0%	0.0%	0.0%	0.0%	0.0%	50.0%	80.0%
% Bicycles on Crosswalk	0.0%	0.0%	0.0%	0.0%	0.0%	0.0%	0.0%	0.0%	0.0%	0.0%	0.0%	0.0%	0.0%	0.0%	0.0%	0.0%	50.0%	20.0%

Turning Movement Data Plot

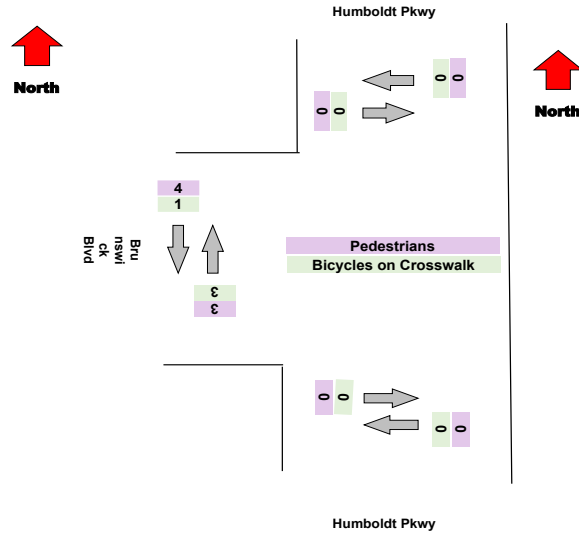
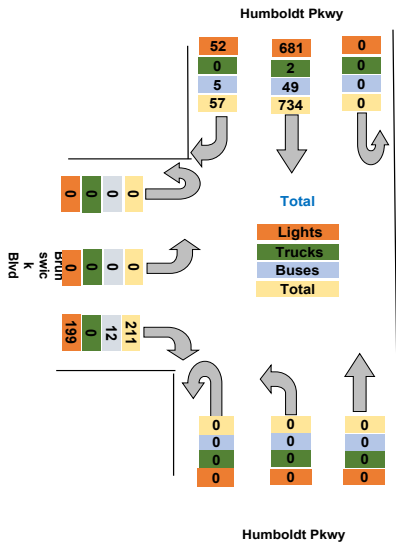

Turning Movement Peak Hour Data (AM)

7:30:00 AM

Leg Direction	Humboldt Pkwy Southbound						Humboldt Pkwy NorthBound						Brunswick Blvd Eastbound					
	Right	Thru	U-Turn	App Total	Peds CW	Peds CCW	Thru	Left	U-Turn	App Total	Peds CW	Peds CCW	Right	Left	U-Turn	App Total	Peds CW	Peds CCW
7:30:00 AM	1	43	0	44	0	0	0	0	0	0	0	0	15	0	0	15	0	0
7:45:00 AM	2	52	0	54	0	0	0	0	0	0	0	0	16	0	0	16	2	0
8:00:00 AM	4	39	0	43	0	0	0	0	0	0	0	0	8	0	0	8	0	0
8:15:00 AM	3	36	0	39	0	0	0	0	0	0	0	0	17	0	0	17	0	0
Grand Total	10	170	0	180	0	0	0	0	0	0	0	0	56	0	0	56	2	0
% Approach	5.6%	94.4%	0.0%	0.0%	0.0%	0.0%	14.2%	0.0%	0.0%	0.0%	0.0%	0.0%	45.1%	41.7%	0.0%	0.0%	0.0%	0.0%
% Total	4.2%	72.0%	0.0%	76.3%	0.0%	0.0%	0.0%	0.0%	0.0%	0.0%	0.0%	0.0%	23.7%	0.0%	0.0%	23.7%	0.0%	0.0%
PHF	0.625	0.817	0.000	0.833	0.000	0.000	0.000	0.000	0.000	0.000	0.000	0.000	0.824	0.000	0.000	0.824	0.000	0.000
Lights	9	160	0	169	0	0	0	0	0	0	0	0	51	0	0	51	0	0
% Lights	90.0%	94.1%	0.0%	93.9%	0.0%	0.0%	0.0%	0.0%	0.0%	0.0%	0.0%	0.0%	91.1%	0.0%	0.0%	91.1%	0.0%	0.0%
Trucks	0	1	0	1	0	0	0	0	0	0	0	0	0	0	0	0	0	0
% Trucks	0.0%	0.6%	0.0%	0.6%	0.0%	0.0%	0.0%	0.0%	0.0%	0.0%	0.0%	0.0%	0.0%	0.0%	0.0%	0.0%	0.0%	0.0%
Buses	1	9	0	10	0	0	0	0	0	0	0	0	5	0	0	5	0	0
% Buses	10.0%	5.3%	0.0%	0.0%	0.0%	0.0%	0.0%	0.0%	0.0%	0.0%	0.0%	0.0%	8.9%	0.0%	0.0%	0.0%	0.0%	0.0%
Pedestrians	0	0	0	0	0	0	0	0	0	0	0	0	0	0	0	0	2	0
% Pedestrians	0.0%	0.0%	0.0%	0.0%	0.0%	0.0%	0.0%	0.0%	0.0%	0.0%	0.0%	0.0%	0.0%	0.0%	0.0%	0.0%	100.0%	0.0%
Bicycles on Crosswalk	0	0	0	0	0	0	0	0	0	0	0	0	0	0	0	0	0	0
% Bicycles on Crosswalk	0.0%	0.0%	0.0%	0.0%	0.0%	0.0%	0.0%	0.0%	0.0%	0.0%	0.0%	0.0%	0.0%	0.0%	0.0%	0.0%	0.0%	0.0%

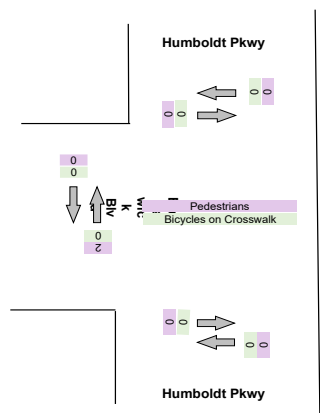
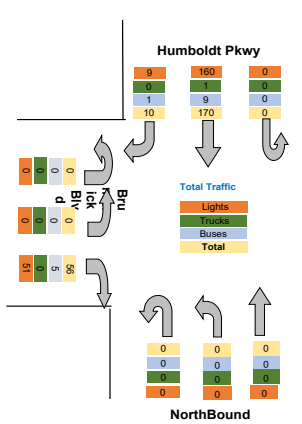

Turning Movement Peak Hour Data (PM)

4:30:00 PM

Leg Direction	Humboldt Pkwy Southbound						Humboldt Pkwy NorthBound						Brunswick Blvd Eastbound					
	Right	Thru	U-Turn	App Total	Peds CW	Peds CCW	Thru	Left	U-Turn	App Total	Peds CW	Peds CCW	Right	Left	U-Turn	App Total	Peds CW	Peds CCW
4:30:00 PM	7	66	0	73	0	0	0	0	0	0	0	0	10	0	0	10	0	0
4:45:00 PM	7	63	0	70	0	0	0	0	0	0	0	0	21	0	0	21	1	1
5:00:00 PM	3	54	0	57	0	0	0	0	0	0	0	0	20	0	0	20	0	1
5:15:00 PM	7	55	0	62	0	0	0	0	0	0	0	0	12	0	0	12	0	0
Grand Total	24	238	0	262	0	0	0	0	0	0	0	0	63	0	0	63	1	2
% Approach	9.2%	90.8%	0.0%	0.0%	0.0%	0.0%	14.2%	0.0%	0.0%	0.0%	0.0%	0.0%	45.1%	41.7%	0.0%	0.0%	0.0%	0.0%
% Total	7.4%	73.2%	0.0%	80.6%	0.0%	0.0%	0.0%	0.0%	0.0%	0.0%	0.0%	0.0%	19.4%	0.0%	0.0%	19.4%	0.0%	0.0%
PHF	0.857	0.902	0.000	0.897	0.000	0.000	0.000	0.000	0.000	0.000	0.000	0.000	0.750	0.000	0.000	0.750	0.000	0.000
Lights	21	219	0	240	0	0	0	0	0	0	0	0	59	0	0	59	0	0
% Lights	87.5%	92.0%	0.0%	91.6%	0.0%	0.0%	0.0%	0.0%	0.0%	0.0%	0.0%	0.0%	93.7%	0.0%	0.0%	93.7%	0.0%	0.0%
Trucks	0	1	0	1	0	0	0	0	0	0	0	0	0	0	0	0	0	0
% Trucks	0.0%	0.4%	0.0%	0.4%	0.0%	0.0%	0.0%	0.0%	0.0%	0.0%	0.0%	0.0%	0.0%	0.0%	0.0%	0.0%	0.0%	0.0%
Buses	3	16	0	19	0	0	0	0	0	0	0	0	4	0	0	4	0	0
% Buses	12.5%	6.7%	0.0%	0.0%	0.0%	0.0%	0.0%	0.0%	0.0%	0.0%	0.0%	0.0%	6.3%	0.0%	0.0%	0.0%	0.0%	0.0%
Pedestrians	0	0	0	0	0	0	0	0	0	0	0	0	0	0	0	0	0	2
% Pedestrians	0.0%	0.0%	0.0%	0.0%	0.0%	0.0%	0.0%	0.0%	0.0%	0.0%	0.0%	0.0%	0.0%	0.0%	0.0%	0.0%	0.0%	100.0%
Bicycles on Crosswalk	0	0	0	0	0	0	0	0	0	0	0	0	0	0	0	0	1	0
% Bicycles on Crosswalk	0.0%	0.0%	0.0%	0.0%	0.0%	0.0%	0.0%	0.0%	0.0%	0.0%	0.0%	0.0%	0.0%	0.0%	0.0%	0.0%	100.0%	0.0%

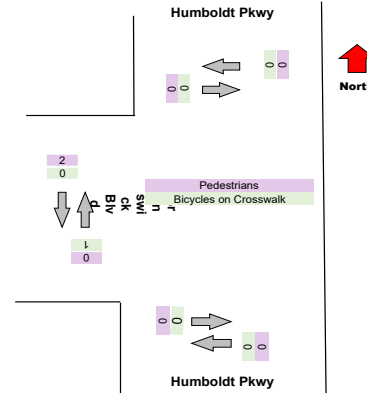
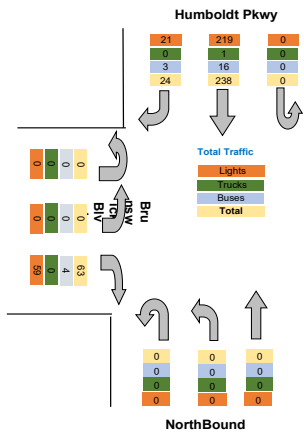

Intersection: Elm St Pine St
 Location: Kennett Square, PA
 Site: 01
 Survey Date: Wednesday, 04-28-2021
 GPS: 42.948550, -72.790034



Total
24
26
50
30
39
59
70
198
51
56
107
90
82
83
91
346
77
74
67
83
304
1002
0.0%
0.0%
932
93.0%
2
0.2%
66
6.6%
0
0.0%
0.0%

Intersection: Elm St Pine St
Location: Kennett Square, PA
Site: 01
Survey Date: Wednesday, 04-28-2021
GPS: 42.948550, -72.790034



Total
59
70
51
56
236
0.843
220
93.2%
1
0.4%
15
6.4%
0
0.0%
0
0.0%

Intersection: Elm St Pine St
Location: Kennett Square, PA
Site: 01
Survey Date: Wednesday, 04-28-2021
GPS: 42.948550, -72.790034



Total
83
91
77
74
325
0.893
299
92.0%
1
0.3%
23
7.1%
0
0.0%
0
0.0%

Project	Labella
Project Code	Labella
Site Name	M
Legs and Movements	All Processed Legs & Movements
Bin Size	15 minutes
Survey Date	2021-10-26, Tuesday
Location	M
Latitude and Longitude	42.915437, -78.843689

	Start	End	PHF
Forced Peak AM	2021/10/26 07:30:00	2021/10/26 08:30:00	0.884
Forced Peak PM	2021/10/26 16:30:00	2021/10/26 17:30:00	0.964
AM Peak	2021/10/26 07:30:00	2021/10/26 08:30:00	0.884
PM Peak	2021/10/26 16:30:00	2021/10/26 17:30:00	0.964

Turning Movement Data

Leg	Humboldt Pkwy						Humboldt Pkwy						Goulding Ave														
	Southbound						NorthBound						Eastbound														
Direction	Right	Thru	U-Turn	App Total	Peds	CW	Peds	CCW	Thru	Left	U-Turn	App Total	Peds	CW	Peds	CCW	Right	Left	U-Turn	App Total	Peds	CW	Peds	CCW			
Start Time	0	80	0	80	0	0	0	0	0	0	0	0	0	0	0	6	0	0	6	1	1	6	0	0	6	1	1
6:30:00 AM	0	80	0	80	0	0	0	0	0	0	0	0	0	0	0	6	0	0	6	1	1	6	0	0	6	1	1
6:45:00 AM	0	108	0	108	0	0	0	0	0	0	0	0	0	0	0	9	0	0	9	0	0	9	0	0	9	0	0
Hourly Total	0	188	0	188	0	0	0	0	0	0	0	0	0	0	0	15	0	0	15	1	1	15	0	0	15	1	1
7:00:00 AM	0	96	0	96	0	0	0	0	0	0	0	0	0	0	0	7	0	0	7	0	0	7	0	0	7	0	0
7:15:00 AM	0	136	0	136	0	0	0	0	0	0	0	0	0	0	0	8	0	0	8	1	1	8	0	0	8	1	1
7:30:00 AM	0	215	0	215	0	0	0	0	0	0	0	0	1	0	0	12	0	0	13	1	0	12	0	0	13	1	0
7:45:00 AM	0	205	0	205	0	0	0	0	0	0	0	0	0	0	0	10	0	0	10	0	1	10	0	0	10	0	1
Hourly Total	0	652	0	652	0	0	0	0	0	0	0	1	0	0	0	37	0	0	38	2	2	37	0	0	38	2	2
8:00:00 AM	0	164	0	164	0	0	0	0	0	0	0	0	0	0	0	12	0	0	12	0	0	12	0	0	12	0	0
8:15:00 AM	0	177	0	177	0	0	0	0	0	0	0	0	0	0	0	10	0	0	10	0	1	10	0	0	10	0	1
Hourly Total	0	341	0	341	0	0	0	0	0	0	0	0	0	0	0	22	0	0	22	0	1	22	0	0	22	0	1
4:00:00 PM	0	231	0	231	0	0	0	0	0	0	0	0	0	0	0	17	0	0	17	0	0	17	0	0	17	0	0
4:15:00 PM	0	189	0	189	0	0	0	0	0	0	0	0	0	0	0	9	0	0	9	1	1	9	0	0	9	1	1
4:30:00 PM	0	188	0	188	0	0	0	0	0	0	0	0	0	0	0	8	0	0	8	0	1	8	0	0	8	0	1
4:45:00 PM	0	181	0	181	0	0	0	0	0	0	0	0	0	0	0	6	0	0	6	0	1	6	0	0	6	0	1
Hourly Total	0	789	0	789	0	0	0	0	0	0	0	0	0	0	0	40	0	0	40	1	3	40	0	0	40	1	3
5:00:00 PM	0	180	0	180	0	0	0	0	0	0	0	0	0	0	0	8	0	0	8	1	0	8	0	0	8	1	0
5:15:00 PM	0	167	0	167	0	0	0	0	0	0	0	0	0	0	0	18	0	0	18	0	0	18	0	0	18	0	0
5:30:00 PM	0	202	0	202	0	0	0	0	0	0	0	0	0	0	0	9	0	0	9	1	0	9	0	0	9	1	0
5:45:00 PM	0	150	0	150	0	0	0	0	0	0	0	0	0	0	0	14	0	0	14	0	0	14	0	0	14	0	0
Hourly Total	0	699	0	699	0	0	0	0	0	0	0	0	0	0	0	49	0	0	49	2	0	49	0	0	49	2	0
Grand Total	0	2669	0	2669	0	0	0	0	0	0	0	1	0	0	0	163	0	0	164	6	7	163	0	0	164	6	7
% Approach	0.0%	100.0%	0.0%	0.0%	0.0%	0.0%	0.0%	0.0%	0.0%	0.0%	0.0%	0.0%	0.0%	0.0%	0.0%	99.4%	0.0%	0.0%	0.0%	0.0%	0.0%	99.4%	0.0%	0.0%	0.0%	0.0%	0.0%
% Total	0.0%	94.2%	0.0%	94.2%	0.0%	0.0%	0.0%	0.0%	0.0%	0.0%	0.0%	0.0%	0.0%	0.0%	0.0%	5.8%	0.0%	0.0%	5.8%	0.0%	0.0%	5.8%	0.0%	0.0%	5.8%	0.0%	0.0%
Lights	0	2588	0	2588	0	0	0	0	0	0	0	0	0	0	0	150	0	0	150	0	0	150	0	0	150	0	0
% Lights	0.0%	97.0%	0.0%	97.0%	0.0%	0.0%	0.0%	0.0%	0.0%	0.0%	0.0%	0.0%	0.0%	0.0%	0.0%	92.0%	0.0%	0.0%	91.5%	0.0%	0.0%	92.0%	0.0%	0.0%	91.5%	0.0%	0.0%
Trucks	0	0	0	0	0	0	0	0	0	0	0	0	0	0	0	0	0	0	0	0	0	0	0	0	0	0	0
% Trucks	0.0%	0.0%	0.0%	0.0%	0.0%	0.0%	0.0%	0.0%	0.0%	0.0%	0.0%	0.0%	0.0%	0.0%	0.0%	0.0%	0.0%	0.0%	0.0%	0.0%	0.0%	0.0%	0.0%	0.0%	0.0%	0.0%	0.0%
Buses	0	80	0	80	0	0	0	0	0	0	0	0	0	0	0	13	0	0	13	0	0	13	0	0	13	0	0
% Buses	0.0%	3.0%	0.0%	0.0%	0.0%	0.0%	0.0%	0.0%	0.0%	0.0%	0.0%	0.0%	0.0%	0.0%	0.0%	8.0%	0.0%	0.0%	0.0%	0.0%	0.0%	8.0%	0.0%	0.0%	0.0%	0.0%	0.0%
Pedestrians	0	0	0	0	0	0	0	0	0	0	0	1	0	0	0	0	0	0	0	6	7	0	0	0	0	6	7
% Pedestrians	0.0%	0.0%	0.0%	0.0%	0.0%	0.0%	0.0%	0.0%	0.0%	0.0%	100.0%	0.0%	0.0%	0.0%	0.0%	0.0%	0.0%	0.0%	0.0%	100.0%	100.0%	0.0%	0.0%	0.0%	0.0%	100.0%	100.0%
% Bicycles on Crosswalk	0.0%	0.0%	0.0%	0.0%	0.0%	0.0%	0.0%	0.0%	0.0%	0.0%	0.0%	0.0%	0.0%	0.0%	0.0%	0.0%	0.0%	0.0%	0.0%	0.0%	0.0%	0.0%	0.0%	0.0%	0.0%	0.0%	0.0%

Turning Movement Data Plot

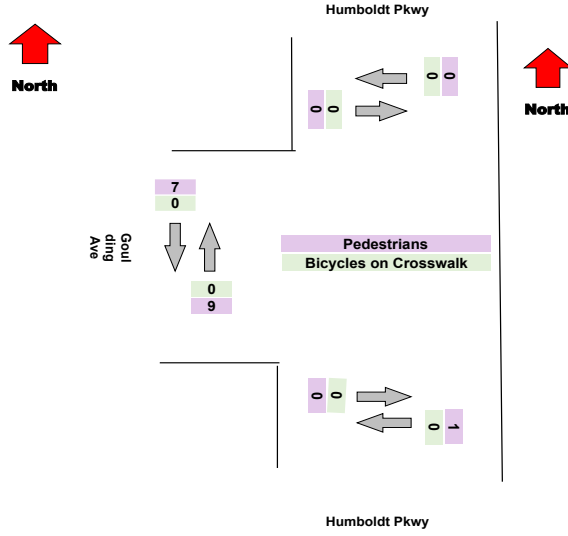
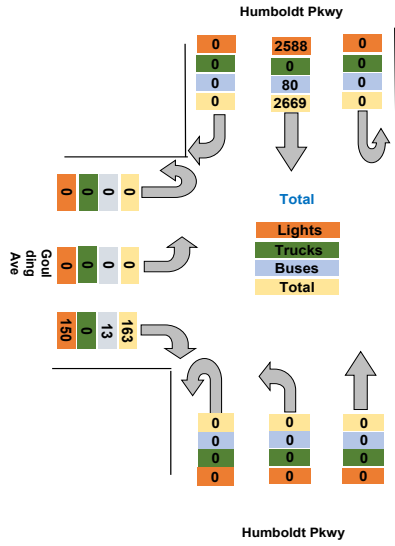

Turning Movement Peak Hour Data (AM)

7:30:00 AM

Leg Direction	Humboldt Pkwy Southbound						Humboldt Pkwy NorthBound						Goulding Ave Eastbound					
	Right	Thru	U-Turn	App Total	Peds CW	Peds CCW	Thru	Left	U-Turn	App Total	Peds CW	Peds CCW	Right	Left	U-Turn	App Total	Peds CW	Peds CCW
7:30:00 AM	0	215	0	215	0	0	0	0	0	1	0	12	0	0	13	1	0	0
7:45:00 AM	0	205	0	205	0	0	0	0	0	0	0	10	0	0	10	0	1	0
8:00:00 AM	0	164	0	164	0	0	0	0	0	0	0	12	0	0	12	0	0	0
8:15:00 AM	0	177	0	177	0	0	0	0	0	0	0	10	0	0	10	0	1	0
Grand Total	0	761	0	761	0	0	0	0	0	1	0	44	0	0	45	1	2	0
% Approach	0.0%	100.0%	0.0%	0.0%	0.0%	0.0%	14.2%	0.0%	0.0%	0.0%	0.0%	45.1%	41.7%	0.0%	0.0%	0.0%	0.0%	0.0%
% Total	0.0%	94.4%	0.0%	94.4%	0.0%	0.0%	0.0%	0.0%	0.0%	0.0%	0.0%	5.5%	0.0%	0.0%	5.6%	0.0%	0.0%	0.0%
PHF	0.000	0.885	0.000	0.885	0.000	0.000	0.000	0.000	0.000	0.000	0.000	0.917	0.000	0.000	0.865	0.000	0.000	0.000
Lights	0	738	0	738	0	0	0	0	0	0	0	40	0	0	40	0	0	0
% Lights	0.0%	97.0%	0.0%	97.0%	0.0%	0.0%	0.0%	0.0%	0.0%	0.0%	0.0%	90.9%	0.0%	0.0%	88.9%	0.0%	0.0%	0.0%
Trucks	0	0	0	0	0	0	0	0	0	0	0	0	0	0	0	0	0	0
% Trucks	0.0%	0.0%	0.0%	0.0%	0.0%	0.0%	0.0%	0.0%	0.0%	0.0%	0.0%	0.0%	0.0%	0.0%	0.0%	0.0%	0.0%	0.0%
Buses	0	22	0	22	0	0	0	0	0	0	0	4	0	0	4	0	0	0
% Buses	0.0%	2.9%	0.0%	0.0%	0.0%	0.0%	0.0%	0.0%	0.0%	0.0%	0.0%	9.1%	0.0%	0.0%	0.0%	0.0%	0.0%	0.0%
Pedestrians	0	0	0	0	0	0	0	0	0	1	0	0	0	0	0	1	2	0
% Pedestrians	0.0%	0.0%	0.0%	0.0%	0.0%	0.0%	0.0%	0.0%	0.0%	100.0%	0.0%	0.0%	0.0%	0.0%	0.0%	100.0%	100.0%	0.0%
Bicycles on Crosswalk	0	0	0	0	0	0	0	0	0	0	0	0	0	0	0	0	0	0
% Bicycles on Crosswalk	0.0%	0.0%	0.0%	0.0%	0.0%	0.0%	0.0%	0.0%	0.0%	0.0%	0.0%	0.0%	0.0%	0.0%	0.0%	0.0%	0.0%	0.0%

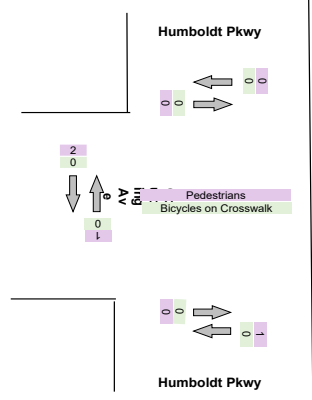
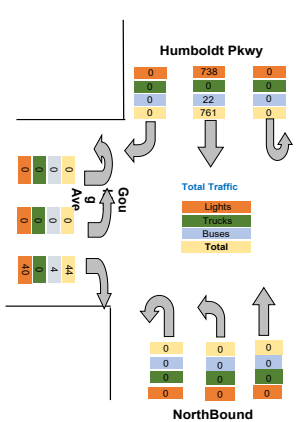

Turning Movement Peak Hour Data (PM)

4:30:00 PM

Leg Direction	Humboldt Pkwy Southbound						Humboldt Pkwy NorthBound						Goulding Ave Eastbound					
	Right	Thru	U-Turn	App	Total	Peds CW/Peds CCW	Thru	Left	U-Turn	App	Total	Peds CW/Peds CCW	Right	Left	U-Turn	App	Total	Peds CW/Peds CCW
4:30:00 PM	0	188	0	188	0	0	0	0	0	0	0	0	8	0	0	8	0	1
4:45:00 PM	0	181	0	181	0	0	0	0	0	0	0	0	6	0	0	6	0	1
5:00:00 PM	0	180	0	180	0	0	0	0	0	0	0	0	8	0	0	8	1	0
5:15:00 PM	0	167	0	167	0	0	0	0	0	0	0	0	18	0	0	18	0	0
Grand Total	0	716	0	716	0	0	0	0	0	0	0	0	40	0	0	40	1	2
% Approach	0.0%	100.0%	0.0%	0.0%	0.0%	0.0%	14.2%	0.0%	0.0%	0.0%	0.0%	0.0%	45.1%	41.7%	0.0%	0.0%	0.0%	0.0%
% Total	0.0%	94.7%	0.0%	94.7%	0.0%	0.0%	0.0%	0.0%	0.0%	0.0%	0.0%	0.0%	5.3%	0.0%	0.0%	5.3%	0.0%	0.0%
PHF	0.000	0.952	0.000	0.952	0.000	0.000	0.000	0.000	0.000	0.000	0.000	0.000	0.556	0.000	0.000	0.556	0.000	0.000
Lights	0	699	0	699	0	0	0	0	0	0	0	0	38	0	0	38	0	0
% Lights	0.0%	97.6%	0.0%	97.6%	0.0%	0.0%	0.0%	0.0%	0.0%	0.0%	0.0%	0.0%	95.0%	0.0%	0.0%	95.0%	0.0%	0.0%
Trucks	0	0	0	0	0	0	0	0	0	0	0	0	0	0	0	0	0	0
% Trucks	0.0%	0.0%	0.0%	0.0%	0.0%	0.0%	0.0%	0.0%	0.0%	0.0%	0.0%	0.0%	0.0%	0.0%	0.0%	0.0%	0.0%	0.0%
Buses	0	17	0	17	0	0	0	0	0	0	0	0	2	0	0	2	0	0
% Buses	0.0%	2.4%	0.0%	0.0%	0.0%	0.0%	0.0%	0.0%	0.0%	0.0%	0.0%	0.0%	5.0%	0.0%	0.0%	0.0%	0.0%	0.0%
Pedestrians	0	0	0	0	0	0	0	0	0	0	0	0	0	0	0	0	1	2
% Pedestrians	0.0%	0.0%	0.0%	0.0%	0.0%	0.0%	0.0%	0.0%	0.0%	0.0%	0.0%	0.0%	0.0%	0.0%	0.0%	0.0%	100.0%	100.0%
Bicycles on Crosswalk	0	0	0	0	0	0	0	0	0	0	0	0	0	0	0	0	0	0
% Bicycles on Crosswalk	0.0%	0.0%	0.0%	0.0%	0.0%	0.0%	0.0%	0.0%	0.0%	0.0%	0.0%	0.0%	0.0%	0.0%	0.0%	0.0%	0.0%	0.0%

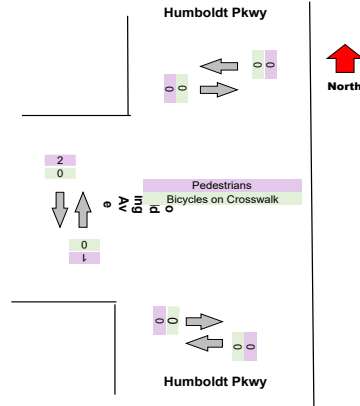
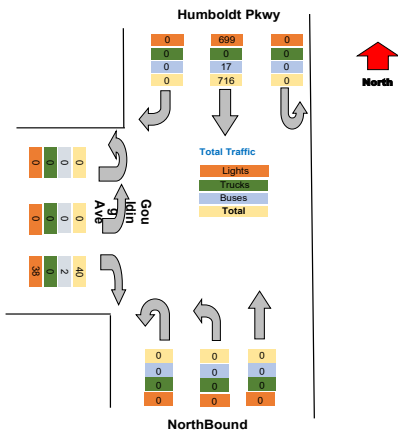

Intersection: Elm St Pine St
 Location: Kennett Square, PA
 Site: 01
 Survey Date: Wednesday, 04-28-2021
 GPS: 42.948550, -72.790034



Total
86
117
203
103
144
228
215
690
176
187
363
248
198
196
187
829
188
185
211
164
748
2833
0.0%
0.0%
2738
96.6%
0
0.0%
93
3.3%
0
0.0%
0.0%

Intersection: Elm St Pine St
Location: Kennett Square, PA
Site: 01
Survey Date: Wednesday, 04-28-2021
GPS: 42.948550, -72.790034



Total
228
215
176
187
806
0.884
778
96.5%
0
0.0%
26
3.2%
0
0.0%
0
0.0%

Intersection: Elm St Pine St
Location: Kennett Square, PA
Site: 01
Survey Date: Wednesday, 04-28-2021
GPS: 42.948550, -72.790034



Total
196
187
188
185
756
0.964
737
97.5%
0
0.0%
19
2.5%
0
0.0%
0
0.0%

Project	Labella
Project Code	Labella
Site Name	M
Legs and Movements	All Processed Legs & Movements
Bin Size	15 minutes
Survey Date	2021-10-27, Wednesday
Location	M
Latitude and Longitude	42.915437, -78.843689

	Start	End	PHF
Forced Peak AM	2021/10/27 07:30:00	2021/10/27 08:30:00	0.886
Forced Peak PM	2021/10/27 16:30:00	2021/10/27 17:30:00	0.932
AM Peak	2021/10/27 07:30:00	2021/10/27 08:30:00	0.886
PM Peak	2021/10/27 16:30:00	2021/10/27 17:30:00	0.932

Turning Movement Data

Leg Direction	Humboldt Pkwy						Humboldt Pkwy						Goulding Ave					
	Southbound						Northbound						Eastbound					
Start Time	Right	Thru	U-Turn	App Total	Peds CW	Peds CCW	Thru	Left	U-Turn	App Total	Peds CW	Peds CCW	Right	Left	U-Turn	App Total	Peds CW	Peds CCW
6:30:00 AM	0	95	0	95	0	0	0	0	0	0	0	0	4	0	0	4	1	1
6:45:00 AM	0	106	0	106	0	0	0	0	0	0	0	1	3	0	0	4	1	1
Hourly Total	0	201	0	201	0	0	0	0	0	0	0	1	7	0	0	8	2	2
7:00:00 AM	0	81	0	81	0	0	0	0	0	0	0	0	6	0	0	6	0	1
7:15:00 AM	0	181	0	181	0	0	0	0	0	0	0	0	12	0	0	12	1	1
7:30:00 AM	0	208	0	208	0	0	0	0	0	0	0	0	11	0	0	11	0	1
7:45:00 AM	0	232	0	232	0	0	0	0	0	0	0	0	8	0	0	8	0	0
Hourly Total	0	702	0	702	0	0	0	0	0	0	0	0	37	0	0	37	1	3
8:00:00 AM	0	206	0	206	0	0	0	0	0	0	0	0	7	0	0	7	0	0
8:15:00 AM	0	173	0	173	0	0	0	0	0	0	0	0	6	0	0	6	0	0
Hourly Total	0	379	0	379	0	0	0	0	0	0	0	0	13	0	0	13	0	0
4:00:00 PM	0	209	0	209	0	0	0	0	0	0	0	0	13	0	0	13	1	1
4:15:00 PM	0	225	0	225	0	0	0	0	0	0	0	0	12	0	0	12	1	1
4:30:00 PM	0	196	0	196	0	0	0	0	0	0	0	0	15	0	0	15	2	0
4:45:00 PM	0	211	0	211	0	0	0	0	0	0	1	0	9	0	0	9	2	1
Hourly Total	0	841	0	841	0	0	0	0	0	0	1	0	49	0	0	49	6	3
5:00:00 PM	0	174	0	174	0	0	0	0	0	0	0	0	10	0	0	10	1	1
5:15:00 PM	0	190	0	190	0	0	0	0	0	0	0	0	15	0	0	15	3	0
5:30:00 PM	0	188	0	188	0	0	0	0	0	0	0	0	13	0	0	13	0	0
5:45:00 PM	0	194	0	194	0	0	0	0	0	0	0	0	11	0	0	11	0	0
Hourly Total	0	746	0	746	0	0	0	0	0	0	0	0	49	0	0	49	4	1
Grand Total	0	2869	0	2869	0	0	0	0	0	0	1	1	155	0	0	156	13	9
% Approach	0.0%	100.0%	0.0%	0.0%	0.0%	0.0%	0.0%	0.0%	0.0%	0.0%	0.0%	0.0%	99.4%	0.0%	0.0%	0.0%	0.0%	0.0%
% Total	0.0%	94.8%	0.0%	94.8%	0.0%	0.0%	0.0%	0.0%	0.0%	0.0%	0.0%	0.0%	5.1%	0.0%	0.0%	5.2%	0.0%	0.0%
Lights	0	2790	0	2790	0	0	0	0	0	0	0	0	143	0	0	143	0	0
% Lights	0.0%	97.2%	0.0%	97.2%	0.0%	0.0%	0.0%	0.0%	0.0%	0.0%	0.0%	0.0%	92.3%	0.0%	0.0%	91.7%	0.0%	0.0%
Trucks	0	1	0	1	0	0	0	0	0	0	0	0	0	0	0	0	0	0
% Trucks	0.0%	0.0%	0.0%	0.0%	0.0%	0.0%	0.0%	0.0%	0.0%	0.0%	0.0%	0.0%	0.0%	0.0%	0.0%	0.0%	0.0%	0.0%
Buses	0	77	0	77	0	0	0	0	0	0	0	0	12	0	0	12	0	0
% Buses	0.0%	2.7%	0.0%	0.0%	0.0%	0.0%	0.0%	0.0%	0.0%	0.0%	0.0%	0.0%	7.7%	0.0%	0.0%	0.0%	0.0%	0.0%
Pedestrians	0	0	0	0	0	0	0	0	0	0	1	1	0	0	0	0	11	9
% Pedestrians	0.0%	0.0%	0.0%	0.0%	0.0%	0.0%	0.0%	0.0%	0.0%	0.0%	100.0%	100.0%	0.0%	0.0%	0.0%	0.0%	84.6%	100.0%
% Bicycles on Crosswalk	0.0%	0.0%	0.0%	0.0%	0.0%	0.0%	0.0%	0.0%	0.0%	0.0%	0.0%	0.0%	0.0%	0.0%	0.0%	0.0%	15.4%	0.0%

Turning Movement Data Plot

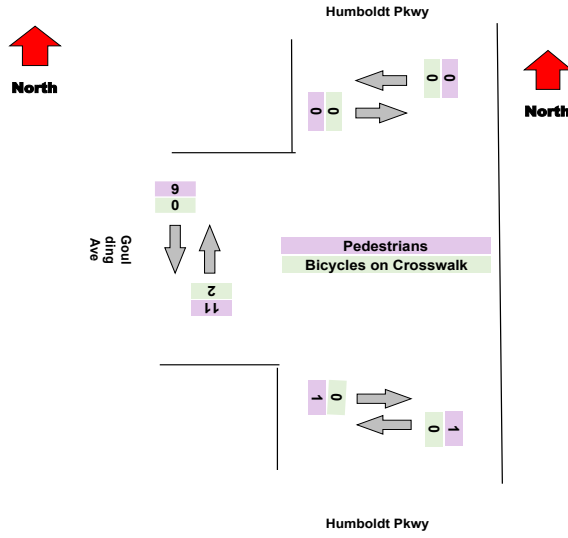
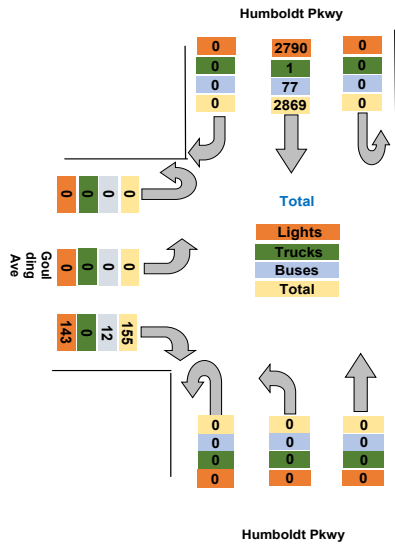

Turning Movement Peak Hour Data (AM)

7:30:00 AM

Leg Direction	Humboldt Pkwy Southbound						Humboldt Pkwy NorthBound						Goulding Ave Eastbound					
	Right	Thru	U-Turn	App Total	Peds CW	Peds CCW	Thru	Left	U-Turn	App Total	Peds CW	Peds CCW	Right	Left	U-Turn	App Total	Peds CW	Peds CCW
7:30:00 AM	0	208	0	208	0	0	0	0	0	0	0	0	11	0	0	11	0	1
7:45:00 AM	0	232	0	232	0	0	0	0	0	0	0	0	8	0	0	8	0	0
8:00:00 AM	0	206	0	206	0	0	0	0	0	0	0	0	7	0	0	7	0	0
8:15:00 AM	0	173	0	173	0	0	0	0	0	0	0	0	6	0	0	6	0	0
Grand Total	0	819	0	819	0	0	0	0	0	0	0	0	32	0	0	32	0	1
% Approach	0.0%	100.0%	0.0%	0.0%	0.0%	0.0%	14.2%	0.0%	0.0%	0.0%	0.0%	0.0%	45.1%	41.7%	0.0%	0.0%	0.0%	0.0%
% Total	0.0%	96.2%	0.0%	96.2%	0.0%	0.0%	0.0%	0.0%	0.0%	0.0%	0.0%	0.0%	3.8%	0.0%	0.0%	3.8%	0.0%	0.0%
PHF	0.000	0.883	0.000	0.883	0.000	0.000	0.000	0.000	0.000	0.000	0.000	0.000	0.727	0.000	0.000	0.727	0.000	0.000
Lights	0	799	0	799	0	0	0	0	0	0	0	0	27	0	0	27	0	0
% Lights	0.0%	97.6%	0.0%	97.6%	0.0%	0.0%	0.0%	0.0%	0.0%	0.0%	0.0%	0.0%	84.4%	0.0%	0.0%	84.4%	0.0%	0.0%
Trucks	0	0	0	0	0	0	0	0	0	0	0	0	0	0	0	0	0	0
% Trucks	0.0%	0.0%	0.0%	0.0%	0.0%	0.0%	0.0%	0.0%	0.0%	0.0%	0.0%	0.0%	0.0%	0.0%	0.0%	0.0%	0.0%	0.0%
Buses	0	20	0	20	0	0	0	0	0	0	0	0	5	0	0	5	0	0
% Buses	0.0%	2.4%	0.0%	2.4%	0.0%	0.0%	0.0%	0.0%	0.0%	0.0%	0.0%	0.0%	15.6%	0.0%	0.0%	15.6%	0.0%	0.0%
Pedestrians	0	0	0	0	0	0	0	0	0	0	0	0	0	0	0	0	0	1
% Pedestrians	0.0%	0.0%	0.0%	0.0%	0.0%	0.0%	0.0%	0.0%	0.0%	0.0%	0.0%	0.0%	0.0%	0.0%	0.0%	0.0%	0.0%	100.0%
Bicycles on Crosswalk	0	0	0	0	0	0	0	0	0	0	0	0	0	0	0	0	0	0
% Bicycles on Crosswalk	0.0%	0.0%	0.0%	0.0%	0.0%	0.0%	0.0%	0.0%	0.0%	0.0%	0.0%	0.0%	0.0%	0.0%	0.0%	0.0%	0.0%	0.0%

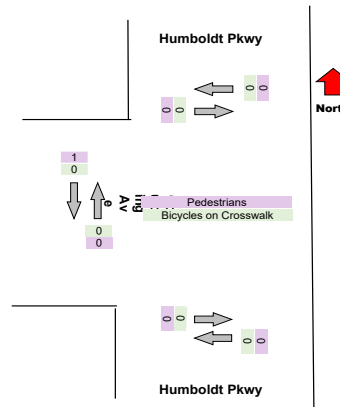
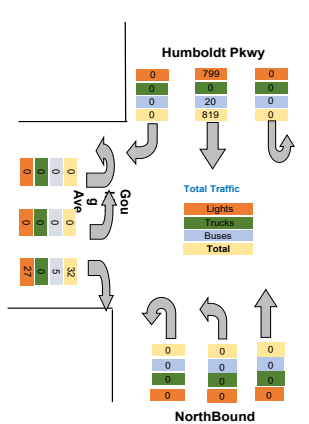

Turning Movement Peak Hour Data (PM)

4:30:00 PM

Leg Direction	Humboldt Pkwy Southbound						Humboldt Pkwy NorthBound						Goulding Ave Eastbound					
	Right	Thru	U-Turn	App	Total	Peds CW/Peds CCW	Thru	Left	U-Turn	App	Total	Peds CW/Peds CCW	Right	Left	U-Turn	App	Total	Peds CW/Peds CCW
4:30:00 PM	0	196	0	196	0	0	0	0	0	0	0	0	15	0	0	15	2	0
4:45:00 PM	0	211	0	211	0	0	0	0	0	0	1	0	9	0	0	9	2	1
5:00:00 PM	0	174	0	174	0	0	0	0	0	0	0	0	10	0	0	10	1	1
5:15:00 PM	0	190	0	190	0	0	0	0	0	0	0	0	15	0	0	15	3	0
Grand Total	0	771	0	771	0	0	0	0	0	0	1	0	49	0	0	49	8	2
% Approach	0.0%	100.0%	0.0%	0.0%	0.0%	0.0%	14.2%	0.0%	0.0%	0.0%	0.0%	0.0%	45.1%	41.7%	0.0%	0.0%	0.0%	0.0%
% Total	0.0%	94.0%	0.0%	94.0%	0.0%	0.0%	0.0%	0.0%	0.0%	0.0%	0.0%	0.0%	6.0%	0.0%	0.0%	6.0%	0.0%	0.0%
PHF	0.000	0.914	0.000	0.914	0.000	0.000	0.000	0.000	0.000	0.000	0.000	0.000	0.817	0.000	0.000	0.817	0.000	0.000
Lights	0	755	0	755	0	0	0	0	0	0	0	0	46	0	0	46	0	0
% Lights	0.0%	97.9%	0.0%	97.9%	0.0%	0.0%	0.0%	0.0%	0.0%	0.0%	0.0%	0.0%	93.9%	0.0%	0.0%	93.9%	0.0%	0.0%
Trucks	0	0	0	0	0	0	0	0	0	0	0	0	0	0	0	0	0	0
% Trucks	0.0%	0.0%	0.0%	0.0%	0.0%	0.0%	0.0%	0.0%	0.0%	0.0%	0.0%	0.0%	0.0%	0.0%	0.0%	0.0%	0.0%	0.0%
Buses	0	16	0	16	0	0	0	0	0	0	0	0	3	0	0	3	0	0
% Buses	0.0%	2.1%	0.0%	0.0%	0.0%	0.0%	0.0%	0.0%	0.0%	0.0%	0.0%	0.0%	6.1%	0.0%	0.0%	0.0%	0.0%	0.0%
Pedestrians	0	0	0	0	0	0	0	0	0	0	1	0	0	0	0	0	6	2
% Pedestrians	0.0%	0.0%	0.0%	0.0%	0.0%	0.0%	0.0%	0.0%	0.0%	0.0%	100.0%	0.0%	0.0%	0.0%	0.0%	0.0%	75.0%	100.0%
Bicycles on Crosswalk	0	0	0	0	0	0	0	0	0	0	0	0	0	0	0	0	2	0
% Bicycles on Crosswalk	0.0%	0.0%	0.0%	0.0%	0.0%	0.0%	0.0%	0.0%	0.0%	0.0%	0.0%	0.0%	0.0%	0.0%	0.0%	0.0%	25.0%	0.0%

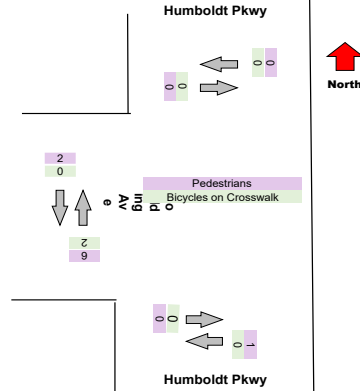
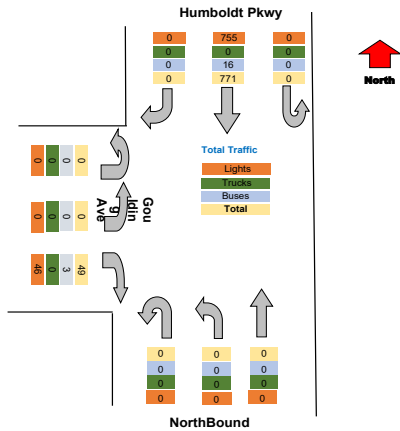

Intersection: Elm St Pine St
 Location: Kennett Square, PA
 Site: 01
 Survey Date: Wednesday, 04-28-2021
 GPS: 42.948550, -72.790034



Total
99
110
209
87
193
219
240
739
213
179
392
222
237
211
220
890
184
205
201
205
795
3025
0.0%
0.0%
2933
97.0%
1
0.0%
89
2.9%
0
0.0%
0.0%

Intersection: Elm St Pine St
Location: Kennett Square, PA
Site: 01
Survey Date: Wednesday, 04-28-2021
GPS: 42.948550, -72.790034



Total
219
240
213
179
851
0.886
826
97.1%
0
0.0%
25
2.9%
0
0.0%
0
0.0%

Intersection: Elm St Pine St
Location: Kennett Square, PA
Site: 01
Survey Date: Wednesday, 04-28-2021
GPS: 42.948550, -72.790034



Total
211
220
184
205
820
0.932
801
97.7%
0
0.0%
19
2.3%
0
0.0%
0
0.0%

Project	Labella
Project Code	Labella
Site Name	M
Legs and Movements	All Processed Legs & Movements
Bin Size	15 minutes
Survey Date	2021-10-28, Thursday
Location	M
Latitude and Longitude	42.915437, -78.843689

	Start	End	PHF
Forced Peak AM	2021/10/28 07:30:00	2021/10/28 08:30:00	0.875
Forced Peak PM	2021/10/28 16:30:00	2021/10/28 17:30:00	0.955
AM Peak	2021/10/28 07:30:00	2021/10/28 08:30:00	0.875
PM Peak	2021/10/28 16:30:00	2021/10/28 17:30:00	0.955

Turning Movement Data

Leg Direction	Humboldt Pkwy Southbound						Humboldt Pkwy NorthBound						Goulding Ave Eastbound						
	Right	Thru	U-Turn	App Total	Peds CW	Peds CCW	Thru	Left	U-Turn	App Total	Peds CW	Peds CCW	Right	Left	U-Turn	App Total	Peds CW	Peds CCW	
Start Time																			
6:30:00 AM	0	80	0	80	0	0	0	0	0	0	0	0	4	0	0	4	1	0	
6:45:00 AM	0	112	0	112	0	0	0	0	0	0	0	0	7	0	0	7	0	0	
Hourly Total	0	192	0	192	0	0	0	0	0	0	0	0	11	0	0	11	1	0	
7:00:00 AM	0	88	0	88	0	0	0	0	0	0	1	4	0	0	5	0	0		
7:15:00 AM	0	137	0	137	0	0	0	0	0	0	0	4	0	0	4	1	1		
7:30:00 AM	0	212	0	212	0	0	0	0	0	0	0	10	0	0	10	2	0		
7:45:00 AM	0	244	0	244	0	0	0	0	0	0	0	11	0	0	11	0	0		
Hourly Total	0	681	0	681	0	0	0	0	0	0	1	29	0	0	30	3	1		
8:00:00 AM	0	210	0	210	0	0	0	0	0	0	0	9	0	0	9	0	1		
8:15:00 AM	0	186	0	186	0	0	0	0	0	0	0	11	0	0	11	0	0		
Hourly Total	0	396	0	396	0	0	0	0	0	0	0	20	0	0	20	0	1		
4:00:00 PM	1	205	0	206	0	0	0	0	0	0	0	17	0	0	17	0	0		
4:15:00 PM	0	229	0	229	0	0	0	0	0	0	0	15	0	0	15	1	2		
4:30:00 PM	0	223	0	223	0	0	0	0	0	0	0	10	0	0	10	1	0		
4:45:00 PM	0	202	0	202	0	0	0	0	0	0	0	19	0	0	19	1	3		
Hourly Total	1	859	0	860	0	0	0	0	0	0	0	61	0	0	61	3	5		
5:00:00 PM	0	206	0	206	0	0	0	0	0	0	0	15	0	0	15	0	1		
5:15:00 PM	0	201	0	201	0	0	0	0	0	0	0	14	0	0	14	0	0		
5:30:00 PM	0	215	0	215	0	0	0	0	0	0	0	17	0	0	17	1	0		
5:45:00 PM	0	201	0	201	0	0	0	0	0	0	0	10	0	0	10	1	2		
Hourly Total	0	823	0	823	0	0	0	0	0	0	0	56	0	0	56	2	3		
Grand Total	1	2951	0	2952	0	0	0	0	0	0	1	177	0	0	178	9	10		
% Approach	0.0%	100.0%	0.0%	0.0%	0.0%	0.0%	0.0%	0.0%	0.0%	0.0%	0.0%	99.4%	0.0%	0.0%	0.0%	0.0%	0.0%	0.0%	
% Total	0.0%	94.3%	0.0%	94.3%	0.0%	0.0%	0.0%	0.0%	0.0%	0.0%	0.0%	5.7%	0.0%	0.0%	5.7%	0.0%	0.0%	0.0%	
Lights	1	2866	0	2867	0	0	0	0	0	0	0	165	0	0	165	0	0	0	
% Lights	100.0%	97.1%	0.0%	97.1%	0.0%	0.0%	0.0%	0.0%	0.0%	0.0%	0.0%	93.2%	0.0%	0.0%	92.7%	0.0%	0.0%	0.0%	
Trucks	0	2	0	2	0	0	0	0	0	0	0	0	0	0	0	0	0	0	
% Trucks	0.0%	0.1%	0.0%	0.1%	0.0%	0.0%	0.0%	0.0%	0.0%	0.0%	0.0%	0.0%	0.0%	0.0%	0.0%	0.0%	0.0%	0.0%	
Buses	0	80	0	80	0	0	0	0	0	0	0	12	0	0	12	0	0	0	
% Buses	0.0%	2.7%	0.0%	0.0%	0.0%	0.0%	0.0%	0.0%	0.0%	0.0%	0.0%	6.8%	0.0%	0.0%	0.0%	0.0%	0.0%	0.0%	
Pedestrians	0	0	0	0	0	0	0	0	0	0	1	0	0	0	0	5	9	0	
% Pedestrians	0.0%	0.0%	0.0%	0.0%	0.0%	0.0%	0.0%	0.0%	0.0%	0.0%	100.0%	0.0%	0.0%	0.0%	0.0%	55.6%	90.0%	0.0%	
% Bicycles on Crosswalk	0.0%	0.0%	0.0%	0.0%	0.0%	0.0%	0.0%	0.0%	0.0%	0.0%	0.0%	0.0%	0.0%	0.0%	0.0%	44.4%	10.0%	0.0%	

Turning Movement Data Plot

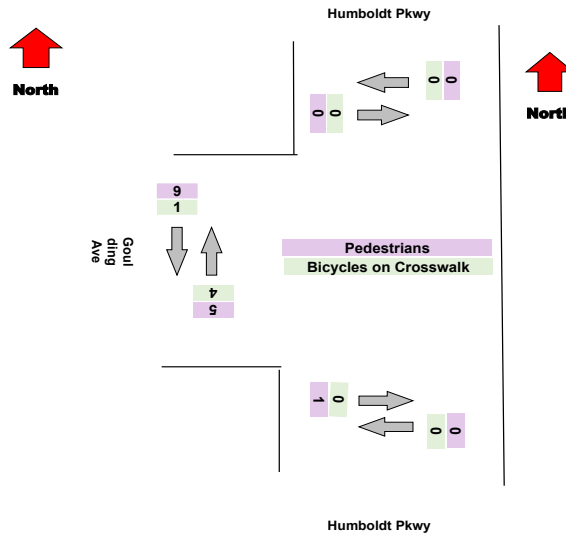
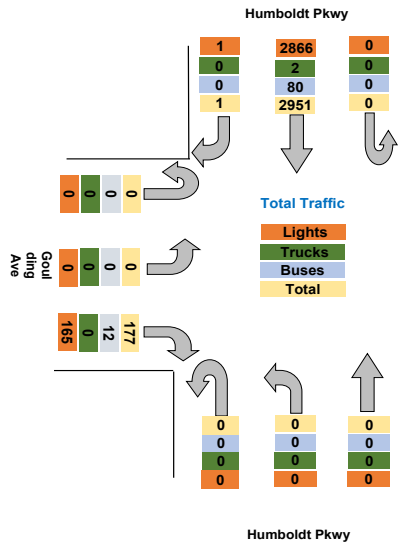

Turning Movement Peak Hour Data (AM)

7:30:00 AM

Leg Direction	Humboldt Pkwy Southbound						Humboldt Pkwy Northbound						Goulding Ave Eastbound					
	Right	Thru	U-Turn	App Total	Peds CW	Peds CCW	Thru	Left	U-Turn	App Total	Peds CW	Peds CCW	Right	Left	U-Turn	App Total	Peds CW	Peds CCW
7:30:00 AM	0	212	0	212	0	0	0	0	0	0	0	0	10	0	0	10	2	0
7:45:00 AM	0	244	0	244	0	0	0	0	0	0	0	0	11	0	0	11	0	0
8:00:00 AM	0	210	0	210	0	0	0	0	0	0	0	0	9	0	0	9	0	1
8:15:00 AM	0	186	0	186	0	0	0	0	0	0	0	0	11	0	0	11	0	0
Grand Total	0	852	0	852	0	0	0	0	0	0	0	0	41	0	0	41	2	1
% Approach	0.0%	100.0%	0.0%	0.0%	0.0%	0.0%	14.2%	0.0%	0.0%	0.0%	0.0%	0.0%	45.1%	41.7%	0.0%	0.0%	0.0%	0.0%
% Total	0.0%	95.4%	0.0%	95.4%	0.0%	0.0%	0.0%	0.0%	0.0%	0.0%	0.0%	0.0%	4.6%	0.0%	0.0%	4.6%	0.0%	0.0%
PHF	0.000	0.873	0.000	0.873	0.000	0.000	0.000	0.000	0.000	0.000	0.000	0.000	0.932	0.000	0.000	0.932	0.000	0.000
Lights	0	828	0	828	0	0	0	0	0	0	0	0	37	0	0	37	0	0
% Lights	0.0%	97.2%	0.0%	97.2%	0.0%	0.0%	0.0%	0.0%	0.0%	0.0%	0.0%	0.0%	90.2%	0.0%	0.0%	90.2%	0.0%	0.0%
Trucks	0	1	0	1	0	0	0	0	0	0	0	0	0	0	0	0	0	0
% Trucks	0.0%	0.1%	0.0%	0.1%	0.0%	0.0%	0.0%	0.0%	0.0%	0.0%	0.0%	0.0%	0.0%	0.0%	0.0%	0.0%	0.0%	0.0%
Buses	0	23	0	23	0	0	0	0	0	0	0	0	4	0	0	4	0	0
% Buses	0.0%	2.7%	0.0%	0.0%	0.0%	0.0%	0.0%	0.0%	0.0%	0.0%	0.0%	0.0%	9.8%	0.0%	0.0%	0.0%	0.0%	0.0%
Pedestrians	0	0	0	0	0	0	0	0	0	0	0	0	0	0	0	0	2	1
% Pedestrians	0.0%	0.0%	0.0%	0.0%	0.0%	0.0%	0.0%	0.0%	0.0%	0.0%	0.0%	0.0%	0.0%	0.0%	0.0%	0.0%	100.0%	100.0%
Bicycles on Crosswalk	0	0	0	0	0	0	0	0	0	0	0	0	0	0	0	0	0	0
% Bicycles on Crosswalk	0.0%	0.0%	0.0%	0.0%	0.0%	0.0%	0.0%	0.0%	0.0%	0.0%	0.0%	0.0%	0.0%	0.0%	0.0%	0.0%	0.0%	0.0%

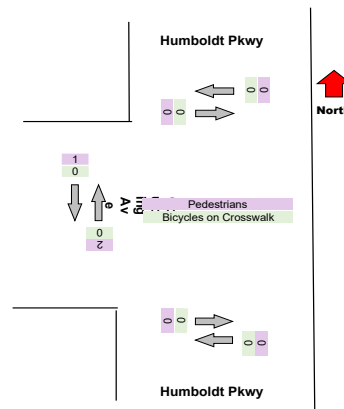
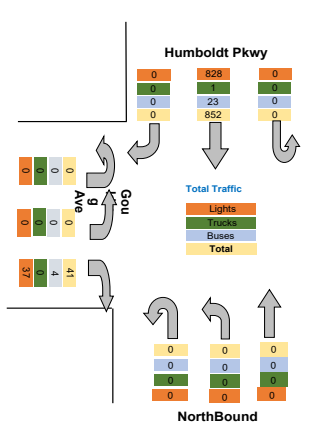

Turning Movement Peak Hour Data (PM)

4:30:00 PM

Leg Direction	Humboldt Pkwy Southbound						Humboldt Pkwy NorthBound						Goulding Ave Eastbound					
	Right	Thru	U-Turn	App Total	Peds CW	Peds CCW	Thru	Left	U-Turn	App Total	Peds CW	Peds CCW	Right	Left	U-Turn	App Total	Peds CW	Peds CCW
4:30:00 PM	0	223	0	223	0	0	0	0	0	0	0	0	10	0	0	10	1	0
4:45:00 PM	0	202	0	202	0	0	0	0	0	0	0	0	19	0	0	19	1	3
5:00:00 PM	0	206	0	206	0	0	0	0	0	0	0	0	15	0	0	15	0	1
5:15:00 PM	0	201	0	201	0	0	0	0	0	0	0	0	14	0	0	14	0	0
Grand Total	0	832	0	832	0	0	0	0	0	0	0	0	58	0	0	58	2	4
% Approach	0.0%	100.0%	0.0%	0.0%	0.0%	0.0%	14.2%	0.0%	0.0%	0.0%	0.0%	0.0%	45.1%	41.7%	0.0%	0.0%	0.0%	0.0%
% Total	0.0%	93.5%	0.0%	93.5%	0.0%	0.0%	0.0%	0.0%	0.0%	0.0%	0.0%	6.5%	0.0%	0.0%	6.5%	0.0%	0.0%	
PHF	0.000	0.933	0.000	0.933	0.000	0.000	0.000	0.000	0.000	0.000	0.000	0.763	0.000	0.000	0.763	0.000	0.000	
Lights	0	809	0	809	0	0	0	0	0	0	0	55	0	0	55	0	0	
% Lights	0.0%	97.2%	0.0%	97.2%	0.0%	0.0%	0.0%	0.0%	0.0%	0.0%	0.0%	94.8%	0.0%	0.0%	94.8%	0.0%	0.0%	
Trucks	0	1	0	1	0	0	0	0	0	0	0	0	0	0	0	0	0	
% Trucks	0.0%	0.1%	0.0%	0.1%	0.0%	0.0%	0.0%	0.0%	0.0%	0.0%	0.0%	0.0%	0.0%	0.0%	0.0%	0.0%	0.0%	
Buses	0	21	0	21	0	0	0	0	0	0	0	3	0	0	3	0	0	
% Buses	0.0%	2.5%	0.0%	0.0%	0.0%	0.0%	0.0%	0.0%	0.0%	0.0%	0.0%	5.2%	0.0%	0.0%	0.0%	0.0%	0.0%	
Pedestrians	0	0	0	0	0	0	0	0	0	0	0	0	0	0	0	0	3	
% Pedestrians	0.0%	0.0%	0.0%	0.0%	0.0%	0.0%	0.0%	0.0%	0.0%	0.0%	0.0%	0.0%	0.0%	0.0%	0.0%	0.0%	75.0%	
Bicycles on Crosswalk	0	0	0	0	0	0	0	0	0	0	0	0	0	0	0	2	1	
% Bicycles on Crosswalk	0.0%	0.0%	0.0%	0.0%	0.0%	0.0%	0.0%	0.0%	0.0%	0.0%	0.0%	0.0%	0.0%	0.0%	0.0%	100.0%	25.0%	

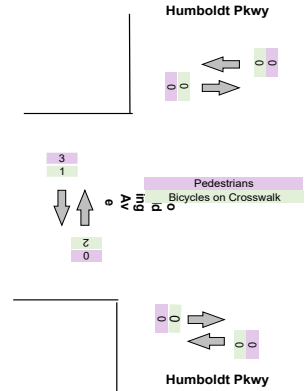
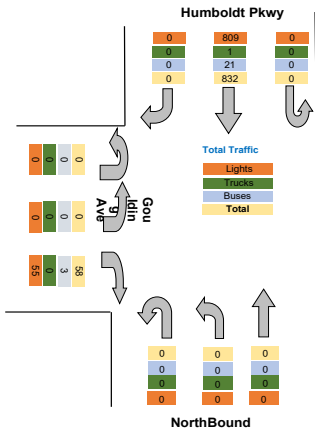

Intersection: Elm St Pine St
Location: Kennett Square, PA
Site: 01
Survey Date: Wednesday, 04-28-2021
GPS: 42.948550, -72.790034



Total
84
119
203
93
141
222
255
711
219
197
416
223
244
233
221
921
221
215
232
211
879
3130
0.0%
0.0%
3032
96.9%
2
0.1%
92
2.9%
0
0.0%
0.0%

Intersection: Elm St Pine St
Location: Kennett Square, PA
Site: 01
Survey Date: Wednesday, 04-28-2021
GPS: 42.948550, -72.790034



Total
222
255
219
197
893
0.875
865
96.9%
1
0.1%
27
3.0%
0
0.0%
0
0.0%

Intersection: Elm St Pine St
Location: Kennett Square, PA
Site: 01
Survey Date: Wednesday, 04-28-2021
GPS: 42.948550, -72.790034



Total
233
221
221
215
890
0.955
864
97.1%
1
0.1%
24
2.7%
0
0.0%
0
0.0%

Turning Movement Data Plot

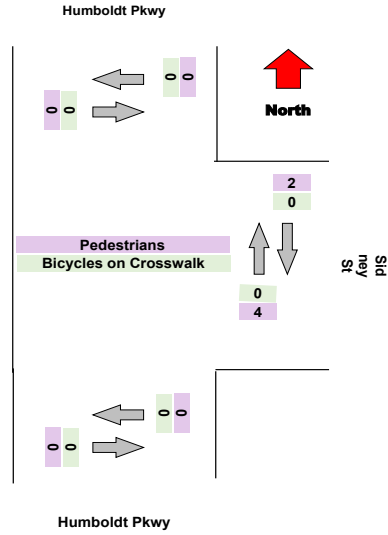
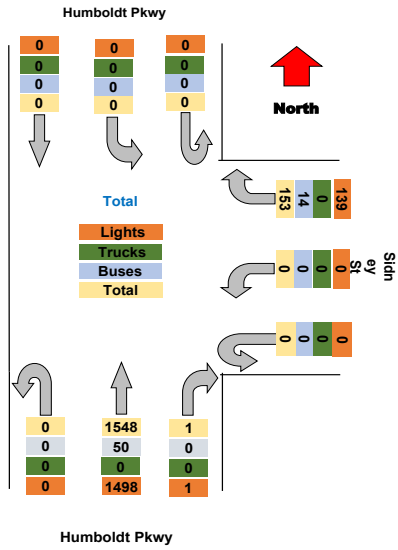

Turning Movement Peak Hour Data (AM)

7:30:00 AM

Leg	Humboldt Pkwy						Sidney St						Humboldt Pkwy						Total			
	Southbound						Westbound						Northbound									
Direction	Thru	Left	U-Turn	App	Total	Peds CW	Peds CCW	Right	Left	U-Turn	App	Total	Peds CW	Peds CCW	Right	Thru	U-Turn	App	Total	Peds CW	Peds CCW	
7:30:00 AM	0	0	0	0	0	0	0	11	0	0	11	1	0	0	0	102	0	0	103	0	0	0
7:45:00 AM	0	0	0	0	0	0	0	7	0	0	7	0	1	1	0	107	0	0	108	0	0	0
8:00:00 AM	0	0	0	0	0	0	0	4	0	0	4	1	0	0	0	98	0	0	99	0	0	0
8:15:00 AM	0	0	0	0	0	0	0	9	0	0	9	0	1	1	0	94	0	0	95	0	0	0
Grand Total	0	0	0	0	0	0	0	31	0	0	31	2	2	0	0	401	0	405	0	0	0	
% Approach	#####	#####	#####	0.0%	0.0%	0.0%	0.0%	14.2%	0.0%	0.0%	0.0%	0.0%	0.0%	0.0%	45.1%	41.7%	0.0%	0.0%	0.0%	0.0%	0.0%	0.0%
% Total	0.0%	0.0%	0.0%	0.0%	0.0%	0.0%	0.0%	7.1%	0.0%	0.0%	7.1%	0.0%	0.0%	0.0%	0.0%	92.0%	0.0%	0.0%	92.9%	0.0%	0.0%	0.0%
PHF	0.000	0.000	0.000	0.000	0.000	0.000	0.000	0.705	0.000	0.000	0.705	0.000	0.000	0.000	0.000	0.937	0.000	0.000	0.938	0.000	0.000	0.000
Lights	0	0	0	0	0	0	0	30	0	0	30	0	0	0	0	388	0	0	388	0	0	0
% Lights	0.0%	0.0%	0.0%	0.0%	0.0%	0.0%	0.0%	96.8%	0.0%	0.0%	96.8%	0.0%	0.0%	0.0%	0.0%	96.8%	0.0%	0.0%	95.8%	0.0%	0.0%	0.0%
Trucks	0	0	0	0	0	0	0	0	0	0	0	0	0	0	0	0	0	0	0	0	0	0
% Trucks	0.0%	0.0%	0.0%	0.0%	0.0%	0.0%	0.0%	0.0%	0.0%	0.0%	0.0%	0.0%	0.0%	0.0%	0.0%	0.0%	0.0%	0.0%	0.0%	0.0%	0.0%	0.0%
Buses	0	0	0	0	0	0	0	1	0	0	1	0	0	0	0	13	0	0	13	0	0	0
% Buses	0.0%	0.0%	0.0%	0.0%	0.0%	0.0%	0.0%	3.2%	0.0%	0.0%	0.0%	0.0%	0.0%	0.0%	0.0%	3.2%	0.0%	0.0%	0.0%	0.0%	0.0%	0.0%
Pedestrians	0	0	0	0	0	0	0	0	0	0	0	2	2	0	0	0	0	0	0	0	0	0
% Pedestrians	0.0%	0.0%	0.0%	0.0%	0.0%	0.0%	0.0%	0.0%	0.0%	0.0%	0.0%	100.0%	100.0%	0.0%	0.0%	0.0%	0.0%	0.0%	0.0%	0.0%	0.0%	0.0%
Bicycles on Crosswalk	0	0	0	0	0	0	0	0	0	0	0	0	0	0	0	0	0	0	0	0	0	0
% Bicycles on Crosswalk	0.0%	0.0%	0.0%	0.0%	0.0%	0.0%	0.0%	0.0%	0.0%	0.0%	0.0%	0.0%	0.0%	0.0%	0.0%	0.0%	0.0%	0.0%	0.0%	0.0%	0.0%	0.0%

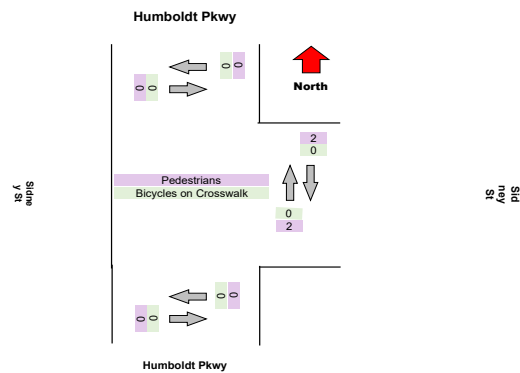
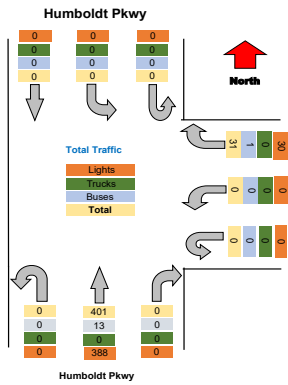

Turning Movement Peak Hour Data (PM)
 4:30:00 PM

Leg	Humboldt Pkwy						Sidney St						Humboldt Pkwy						Total										
	Southbound						Westbound						Northbound																
Direction	Thru	Left	U-Turn	App	Total	Peds	CW	Peds	CCW	Right	Left	U-Turn	App	Total	Peds	CW	Peds	CCW	Right	Thru	U-Turn	App	Total	Peds	CW	Peds	CCW		
4:30:00 PM	0	0	0	0	0	0	0	0	0	9	0	0	0	9	0	0	0	0	0	0	115	0	0	115	0	0	0	0	124
4:45:00 PM	0	0	0	0	0	0	0	0	0	15	0	0	0	15	0	0	0	0	0	0	91	0	0	91	0	0	0	0	106
5:00:00 PM	0	0	0	0	0	0	0	0	0	9	0	0	0	9	0	1	0	0	0	105	0	0	105	0	0	0	0	114	
5:15:00 PM	0	0	0	0	0	0	0	0	0	8	0	0	0	8	0	0	0	0	0	123	0	0	123	0	0	0	0	131	
Grand Total	0	0	0	0	0	0	0	0	0	41	0	0	0	41	0	1	0	0	0	434	0	0	434	0	0	0	0	475	
% Approach	#####	#####	#####	0.0%	0.0%	0.0%	0.0%	0.0%	0.0%	14.2%	0.0%	0.0%	0.0%	0.0%	0.0%	0.0%	0.0%	0.0%	45.1%	41.7%	0.0%	0.0%	0.0%	0.0%	0.0%	0.0%	0.0%		
% Total	0.0%	0.0%	0.0%	0.0%	0.0%	0.0%	0.0%	0.0%	0.0%	8.6%	0.0%	0.0%	0.0%	8.6%	0.0%	0.0%	0.0%	0.0%	0.0%	91.4%	0.0%	0.0%	91.4%	0.0%	0.0%	0.0%	0.0%		
PHF	0.000	0.000	0.000	0.000	0.000	0.000	0.000	0.000	0.000	0.683	0.000	0.000	0.000	0.683	0.000	0.000	0.000	0.000	0.000	0.882	0.000	0.000	0.882	0.000	0.000	0.000	0.000	0.906	
Lights	0	0	0	0	0	0	0	0	0	37	0	0	0	37	0	0	0	0	0	424	0	0	424	0	0	0	0	461	
% Lights	0.0%	0.0%	0.0%	0.0%	0.0%	0.0%	0.0%	0.0%	0.0%	90.2%	0.0%	0.0%	0.0%	90.2%	0.0%	0.0%	0.0%	0.0%	0.0%	97.7%	0.0%	0.0%	97.7%	0.0%	0.0%	0.0%	0.0%	97.1%	
Trucks	0	0	0	0	0	0	0	0	0	4	0	0	0	4	0	0	0	0	0	0	0	0	0	0	0	0	0	0	
% Trucks	0.0%	0.0%	0.0%	0.0%	0.0%	0.0%	0.0%	0.0%	0.0%	0.0%	0.0%	0.0%	0.0%	0.0%	0.0%	0.0%	0.0%	0.0%	0.0%	0.0%	0.0%	0.0%	0.0%	0.0%	0.0%	0.0%	0.0%	0.0%	
Buses	0	0	0	0	0	0	0	0	0	4	0	0	0	4	0	0	0	0	0	10	0	0	10	0	0	0	0	14	
% Buses	0.0%	0.0%	0.0%	0.0%	0.0%	0.0%	0.0%	0.0%	0.0%	9.8%	0.0%	0.0%	0.0%	0.0%	0.0%	0.0%	0.0%	0.0%	0.0%	2.3%	0.0%	0.0%	0.0%	0.0%	0.0%	0.0%	0.0%	2.9%	
Pedestrians	0	0	0	0	0	0	0	0	0	0	0	0	0	0	0	1	0	0	0	0	0	0	0	0	0	0	0	0	
% Pedestrians	0.0%	0.0%	0.0%	0.0%	0.0%	0.0%	0.0%	0.0%	0.0%	0.0%	0.0%	0.0%	0.0%	0.0%	0.0%	100.0%	0.0%	0.0%	0.0%	0.0%	0.0%	0.0%	0.0%	0.0%	0.0%	0.0%	0.0%	0.0%	
Bicycles on Crosswalk	0	0	0	0	0	0	0	0	0	0	0	0	0	0	0	0	0	0	0	0	0	0	0	0	0	0	0	0	
% Bicycles on Crosswalk	0.0%	0.0%	0.0%	0.0%	0.0%	0.0%	0.0%	0.0%	0.0%	0.0%	0.0%	0.0%	0.0%	0.0%	0.0%	0.0%	0.0%	0.0%	0.0%	0.0%	0.0%	0.0%	0.0%	0.0%	0.0%	0.0%	0.0%	0.0%	

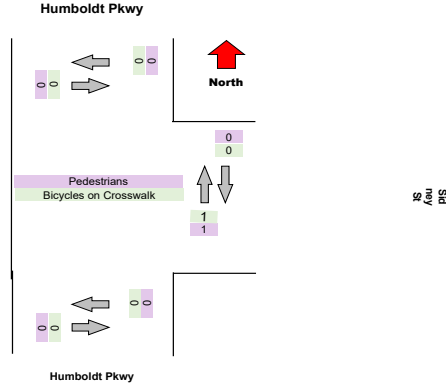
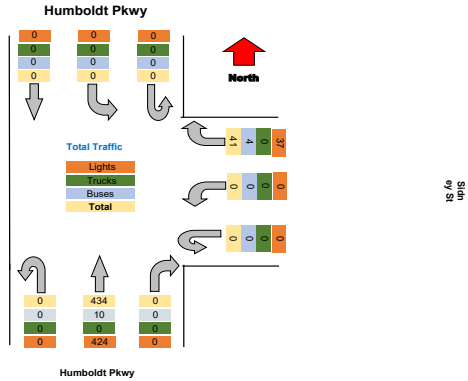

Turning Movement Data Plot

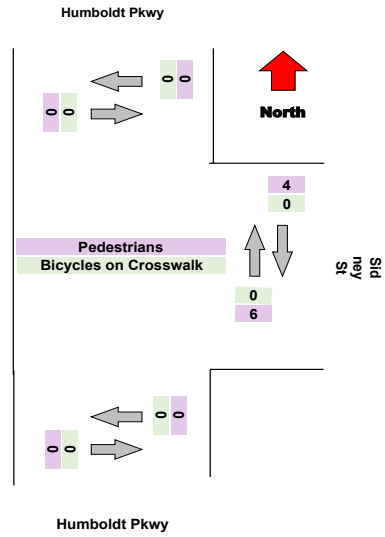
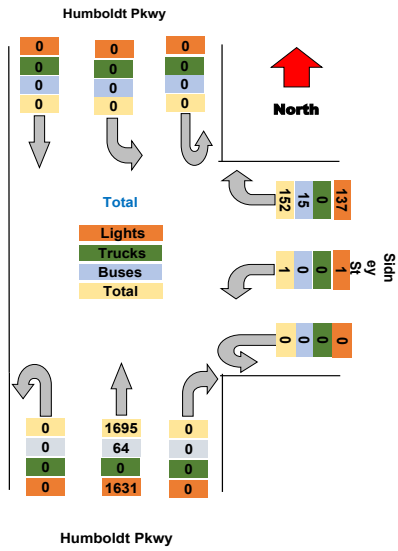

Intersection: Elm St Pine St
 Location: Kennett Square, PA
 Site: 01
 Survey Date: Wednesday, 04-28-2021
 GPS: 42.948550, -72.790034



Turning Movement Peak Hour Data (AM)
 7:30:00 AM

Leg	Humboldt Pkwy						Sidney St						Humboldt Pkwy						Total										
	Southbound						Westbound						Northbound																
Direction	Thru	Left	U-Turn	App	Total	Peds	CW	Peds	CCW	Right	Left	U-Turn	App	Total	Peds	CW	Peds	CCW	Right	Thru	U-Turn	App	Total	Peds	CW	Peds	CCW		
7:30:00 AM	0	0	0	0	0	0	0	0	0	10	0	0	10	1	0	0	0	0	0	0	104	0	105	0	0	0	0	0	115
7:45:00 AM	0	0	0	0	0	0	0	0	0	13	0	0	13	1	0	0	0	0	0	101	0	102	0	0	0	0	0	115	
8:00:00 AM	0	0	0	0	0	0	0	0	0	10	0	0	10	0	0	0	0	0	0	112	0	112	0	0	0	0	0	122	
8:15:00 AM	0	0	0	0	0	0	0	0	0	3	0	0	3	1	1	1	1	1	0	74	0	76	0	0	0	0	0	79	
Grand Total	0	0	0	0	0	0	0	0	0	36	0	0	36	3	1	1	1	1	0	391	0	395	0	0	0	0	0	431	
% Approach	#####	#####	#####	0.0%	0.0%	0.0%	0.0%	0.0%	0.0%	14.2%	0.0%	0.0%	0.0%	0.0%	0.0%	0.0%	0.0%	0.0%	45.1%	41.7%	0.0%	0.0%	0.0%	0.0%	0.0%	0.0%	0.0%		
% Total	0.0%	0.0%	0.0%	0.0%	0.0%	0.0%	0.0%	0.0%	0.0%	8.4%	0.0%	0.0%	8.4%	0.0%	0.0%	0.0%	0.0%	0.0%	0.0%	90.7%	0.0%	91.6%	0.0%	0.0%	0.0%	0.0%	0.0%		
PHF	0.000	0.000	0.000	0.000	0.000	0.000	0.000	0.000	0.000	0.692	0.000	0.000	0.692	0.000	0.000	0.000	0.000	0.000	0.000	0.873	0.000	0.882	0.000	0.000	0.000	0.000	0.000	0.883	
Lights	0	0	0	0	0	0	0	0	0	36	0	0	36	0	0	0	0	0	0	377	0	377	0	0	0	0	0	413	
% Lights	0.0%	0.0%	0.0%	0.0%	0.0%	0.0%	0.0%	0.0%	0.0%	100.0%	0.0%	0.0%	100.0%	0.0%	0.0%	0.0%	0.0%	0.0%	0.0%	96.4%	0.0%	95.4%	0.0%	0.0%	0.0%	0.0%	0.0%	95.8%	
Trucks	0	0	0	0	0	0	0	0	0	0	0	0	0	0	0	0	0	0	0	0	0	0	0	0	0	0	0	0	
% Trucks	0.0%	0.0%	0.0%	0.0%	0.0%	0.0%	0.0%	0.0%	0.0%	0.0%	0.0%	0.0%	0.0%	0.0%	0.0%	0.0%	0.0%	0.0%	0.0%	0.0%	0.0%	0.0%	0.0%	0.0%	0.0%	0.0%	0.0%	0.0%	
Buses	0	0	0	0	0	0	0	0	0	0	0	0	0	0	0	0	0	0	0	14	0	14	0	0	0	0	0	14	
% Buses	0.0%	0.0%	0.0%	0.0%	0.0%	0.0%	0.0%	0.0%	0.0%	0.0%	0.0%	0.0%	0.0%	0.0%	0.0%	0.0%	0.0%	0.0%	0.0%	3.6%	0.0%	0.0%	0.0%	0.0%	0.0%	0.0%	0.0%	3.2%	
Pedestrians	0	0	0	0	0	0	0	0	0	0	0	0	0	3	1	0	0	0	0	0	0	0	0	0	0	0	0	0	
% Pedestrians	0.0%	0.0%	0.0%	0.0%	0.0%	0.0%	0.0%	0.0%	0.0%	0.0%	0.0%	0.0%	0.0%	100.0%	100.0%	0.0%	0.0%	0.0%	0.0%	0.0%	0.0%	0.0%	0.0%	0.0%	0.0%	0.0%	0.0%	0.0%	
Bicycles on Crosswalk	0	0	0	0	0	0	0	0	0	0	0	0	0	0	0	0	0	0	0	0	0	0	0	0	0	0	0	0	
% Bicycles on Crosswalk	0.0%	0.0%	0.0%	0.0%	0.0%	0.0%	0.0%	0.0%	0.0%	0.0%	0.0%	0.0%	0.0%	0.0%	0.0%	0.0%	0.0%	0.0%	0.0%	0.0%	0.0%	0.0%	0.0%	0.0%	0.0%	0.0%	0.0%	0.0%	

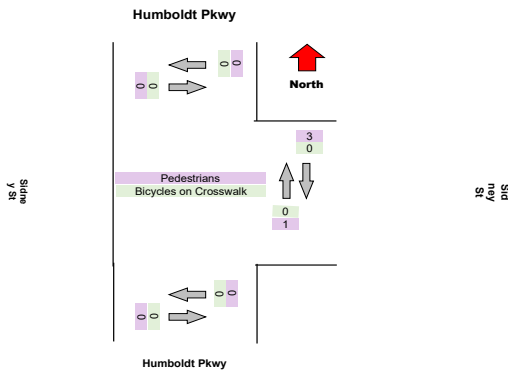
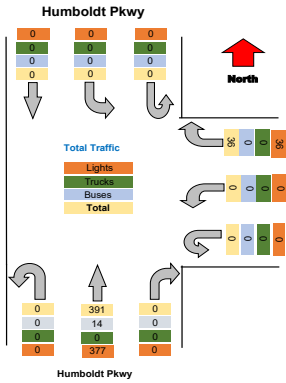

Turning Movement Peak Hour Data (PM)
 4:30:00 PM

Leg Direction	Humboldt Pkwy Southbound						Sidney St Westbound						Humboldt Pkwy Northbound						Total
	Thru	Left	U-Turn	App Total	Peds CW	Peds CCW	Right	Left	U-Turn	App Total	Peds CW	Peds CCW	Right	Thru	U-Turn	App Total	Peds CW	Peds CCW	
4:30:00 PM	0	0	0	0	0	0	15	0	0	15	0	1	0	139	0	139	0	0	154
4:45:00 PM	0	0	0	0	0	0	13	0	0	13	0	0	0	123	0	123	0	0	136
5:00:00 PM	0	0	0	0	0	0	6	0	0	6	0	0	0	123	0	123	0	0	129
5:15:00 PM	0	0	0	0	0	0	7	0	0	7	0	1	0	137	0	137	0	0	144
Grand Total	0	0	0	0	0	0	41	0	0	41	0	2	0	522	0	522	0	0	563
% Approach	#####	#####	#####	0.0%	0.0%	0.0%	14.2%	0.0%	0.0%	0.0%	0.0%	0.0%	45.1%	41.7%	0.0%	0.0%	0.0%	0.0%	
% Total	0.0%	0.0%	0.0%	0.0%	0.0%	0.0%	7.3%	0.0%	0.0%	7.3%	0.0%	0.0%	0.0%	92.7%	0.0%	92.7%	0.0%	0.0%	
PHF	0.000	0.000	0.000	0.000	0.000	0.000	0.683	0.000	0.000	0.683	0.000	0.000	0.000	0.939	0.000	0.939	0.000	0.000	0.914
Lights	0	0	0	0	0	0	36	0	0	36	0	0	0	508	0	508	0	0	544
% Lights	0.0%	0.0%	0.0%	0.0%	0.0%	0.0%	87.8%	0.0%	0.0%	87.8%	0.0%	0.0%	0.0%	97.3%	0.0%	97.3%	0.0%	0.0%	96.6%
Trucks	0	0	0	0	0	0	0	0	0	0	0	0	0	0	0	0	0	0	0
% Trucks	0.0%	0.0%	0.0%	0.0%	0.0%	0.0%	0.0%	0.0%	0.0%	0.0%	0.0%	0.0%	0.0%	0.0%	0.0%	0.0%	0.0%	0.0%	0.0%
Buses	0	0	0	0	0	0	5	0	0	5	0	0	0	14	0	14	0	0	19
% Buses	0.0%	0.0%	0.0%	0.0%	0.0%	0.0%	12.2%	0.0%	0.0%	0.0%	0.0%	0.0%	0.0%	2.7%	0.0%	0.0%	0.0%	0.0%	3.4%
Pedestrians	0	0	0	0	0	0	0	0	0	0	0	2	0	0	0	0	0	0	0
% Pedestrians	0.0%	0.0%	0.0%	0.0%	0.0%	0.0%	0.0%	0.0%	0.0%	0.0%	0.0%	100.0%	0.0%	0.0%	0.0%	0.0%	0.0%	0.0%	0.0%
Bicycles on Crosswalk	0	0	0	0	0	0	0	0	0	0	0	0	0	0	0	0	0	0	0
% Bicycles on Crosswalk	0.0%	0.0%	0.0%	0.0%	0.0%	0.0%	0.0%	0.0%	0.0%	0.0%	0.0%	0.0%	0.0%	0.0%	0.0%	0.0%	0.0%	0.0%	0.0%

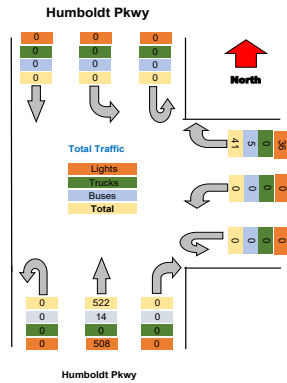

Sidney St

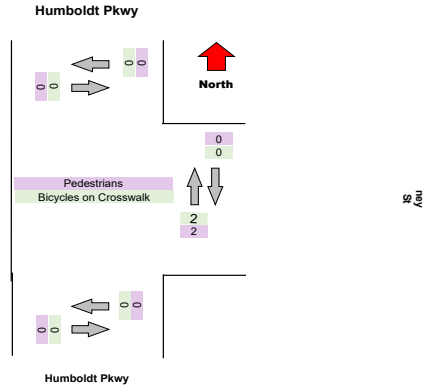

Turning Movement Data Plot

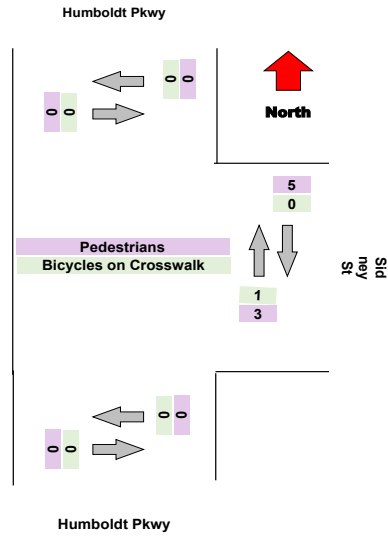
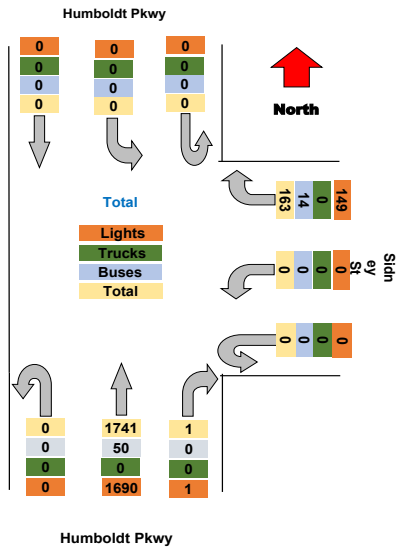

Turning Movement Peak Hour Data (AM)

7:30:00 AM

Leg	Humboldt Pkwy						Sidney St						Humboldt Pkwy						Total			
	Southbound						Westbound						Northbound									
Direction	Thru	Left	U-Turn	App	Total	Peds CW	Peds CCW	Right	Left	U-Turn	App	Total	Peds CW	Peds CCW	Right	Thru	U-Turn	App	Total	Peds CW	Peds CCW	
7:30:00 AM	0	0	0	0	0	0	0	9	0	0	9	1	0	0	0	102	0	0	103	0	0	0
7:45:00 AM	0	0	0	0	0	0	0	12	0	0	12	1	0	0	0	128	0	0	129	0	0	0
8:00:00 AM	0	0	0	0	0	0	0	8	0	0	8	1	0	0	0	113	0	0	114	0	0	0
8:15:00 AM	0	0	0	0	0	0	0	6	0	0	6	0	1	0	0	86	0	0	87	0	0	0
Grand Total	0	0	0	0	0	0	0	35	0	0	35	3	1	0	0	429	0	433	0	0	0	
% Approach	#####	#####	#####	0.0%	0.0%	0.0%	0.0%	14.2%	0.0%	0.0%	0.0%	0.0%	0.0%	0.0%	45.1%	41.7%	0.0%	0.0%	0.0%	0.0%	0.0%	0.0%
% Total	0.0%	0.0%	0.0%	0.0%	0.0%	0.0%	0.0%	7.5%	0.0%	0.0%	7.5%	0.0%	0.0%	0.0%	0.0%	91.7%	0.0%	0.0%	92.5%	0.0%	0.0%	0.0%
PHF	0.000	0.000	0.000	0.000	0.000	0.000	0.000	0.729	0.000	0.000	0.729	0.000	0.000	0.000	0.000	0.838	0.000	0.839	0.000	0.000	0.000	0.830
Lights	0	0	0	0	0	0	0	35	0	0	35	0	0	0	0	416	0	416	0	0	0	451
% Lights	0.0%	0.0%	0.0%	0.0%	0.0%	0.0%	0.0%	100.0%	0.0%	0.0%	100.0%	0.0%	0.0%	0.0%	0.0%	97.0%	0.0%	96.1%	0.0%	0.0%	0.0%	96.4%
Trucks	0	0	0	0	0	0	0	0	0	0	0	0	0	0	0	0	0	0	0	0	0	0
% Trucks	0.0%	0.0%	0.0%	0.0%	0.0%	0.0%	0.0%	0.0%	0.0%	0.0%	0.0%	0.0%	0.0%	0.0%	0.0%	0.0%	0.0%	0.0%	0.0%	0.0%	0.0%	0.0%
Buses	0	0	0	0	0	0	0	0	0	0	0	0	0	0	0	13	0	13	0	0	0	13
% Buses	0.0%	0.0%	0.0%	0.0%	0.0%	0.0%	0.0%	0.0%	0.0%	0.0%	0.0%	0.0%	0.0%	0.0%	0.0%	3.0%	0.0%	0.0%	0.0%	0.0%	0.0%	2.8%
Pedestrians	0	0	0	0	0	0	0	0	0	0	0	3	1	0	0	0	0	0	0	0	0	0
% Pedestrians	0.0%	0.0%	0.0%	0.0%	0.0%	0.0%	0.0%	0.0%	0.0%	0.0%	0.0%	100.0%	100.0%	0.0%	0.0%	0.0%	0.0%	0.0%	0.0%	0.0%	0.0%	0.0%
Bicycles on Crosswalk	0	0	0	0	0	0	0	0	0	0	0	0	0	0	0	0	0	0	0	0	0	0
% Bicycles on Crosswalk	0.0%	0.0%	0.0%	0.0%	0.0%	0.0%	0.0%	0.0%	0.0%	0.0%	0.0%	0.0%	0.0%	0.0%	0.0%	0.0%	0.0%	0.0%	0.0%	0.0%	0.0%	0.0%

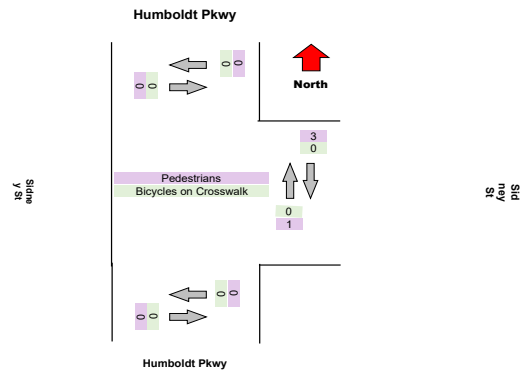
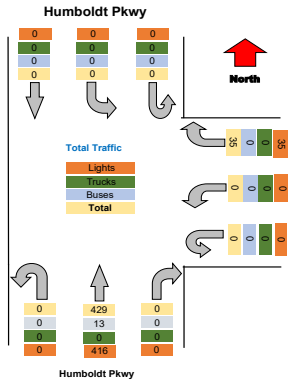

Turning Movement Peak Hour Data (PM)
 4:30:00 PM

Leg	Humboldt Pkwy						Sidney St						Humboldt Pkwy						Total						
	Southbound						Westbound						Northbound												
Direction	Thru	Left	U-Turn	App	Total		Right	Left	U-Turn	App	Total	Peds	CW	Peds	CCW	Right	Thru	U-Turn	App	Total	Peds	CW	Peds	CCW	
4:30:00 PM	0	0	0	0	0	0	15	0	0	15	0	1	0	123	0	123	0	0	0	123	0	0	0	0	138
4:45:00 PM	0	0	0	0	0	0	10	0	0	10	0	0	0	120	0	120	0	0	0	120	0	0	0	0	130
5:00:00 PM	0	0	0	0	0	0	10	0	0	10	0	0	0	152	0	152	0	0	0	152	0	0	0	0	162
5:15:00 PM	0	0	0	0	0	0	7	0	0	7	1	1	0	122	0	122	0	0	0	122	0	0	0	0	129
Grand Total	0	0	0	0	0	0	42	0	0	42	1	2	0	517	0	517	0	0	0	517	0	0	0	559	
% Approach	#####	#####	#####	0.0%	0.0%	0.0%	14.2%	0.0%	0.0%	0.0%	0.0%	0.0%	45.1%	41.7%	0.0%	0.0%	0.0%	0.0%	0.0%	0.0%	0.0%	0.0%	0.0%	0.0%	0.0%
% Total	0.0%	0.0%	0.0%	0.0%	0.0%	0.0%	7.5%	0.0%	0.0%	7.5%	0.0%	0.0%	0.0%	92.5%	0.0%	92.5%	0.0%	0.0%	0.0%	0.0%	0.0%	0.0%	0.0%	0.0%	0.0%
PHF	0.000	0.000	0.000	0.000	0.000	0.000	0.700	0.000	0.000	0.700	0.000	0.000	0.000	0.850	0.000	0.850	0.000	0.000	0.000	0.000	0.000	0.000	0.000	0.000	0.863
Lights	0	0	0	0	0	0	38	0	0	38	0	0	0	512	0	512	0	0	0	0	0	0	0	0	550
% Lights	0.0%	0.0%	0.0%	0.0%	0.0%	0.0%	90.5%	0.0%	0.0%	90.5%	0.0%	0.0%	0.0%	99.0%	0.0%	99.0%	0.0%	0.0%	0.0%	0.0%	0.0%	0.0%	0.0%	0.0%	98.4%
Trucks	0	0	0	0	0	0	4	0	0	4	0	0	0	0	0	0	0	0	0	0	0	0	0	0	0
% Trucks	0.0%	0.0%	0.0%	0.0%	0.0%	0.0%	0.0%	0.0%	0.0%	0.0%	0.0%	0.0%	0.0%	0.0%	0.0%	0.0%	0.0%	0.0%	0.0%	0.0%	0.0%	0.0%	0.0%	0.0%	0.0%
Buses	0	0	0	0	0	0	4	0	0	4	0	0	0	5	0	5	0	0	0	0	0	0	0	0	9
% Buses	0.0%	0.0%	0.0%	0.0%	0.0%	0.0%	9.5%	0.0%	0.0%	9.5%	0.0%	0.0%	0.0%	1.0%	0.0%	1.0%	0.0%	0.0%	0.0%	0.0%	0.0%	0.0%	0.0%	0.0%	1.6%
Pedestrians	0	0	0	0	0	0	0	0	0	0	1	1	0	0	0	0	0	0	0	0	0	0	0	0	0
% Pedestrians	0.0%	0.0%	0.0%	0.0%	0.0%	0.0%	0.0%	0.0%	0.0%	0.0%	100.0%	50.0%	0.0%	0.0%	0.0%	0.0%	0.0%	0.0%	0.0%	0.0%	0.0%	0.0%	0.0%	0.0%	0.0%
Bicycles on Crosswalk	0	0	0	0	0	0	0	0	0	0	0	1	0	0	0	0	0	0	0	0	0	0	0	0	0
% Bicycles on Crosswalk	0.0%	0.0%	0.0%	0.0%	0.0%	0.0%	0.0%	0.0%	0.0%	0.0%	0.0%	50.0%	0.0%	0.0%	0.0%	0.0%	0.0%	0.0%	0.0%	0.0%	0.0%	0.0%	0.0%	0.0%	0.0%

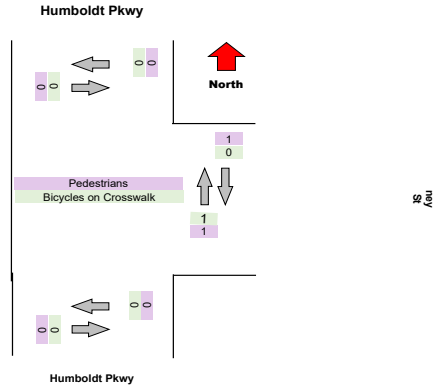
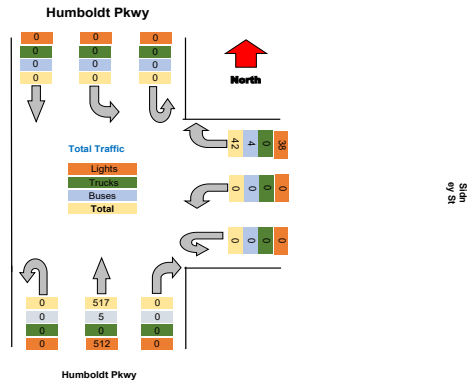

Turning Movement Data Plot

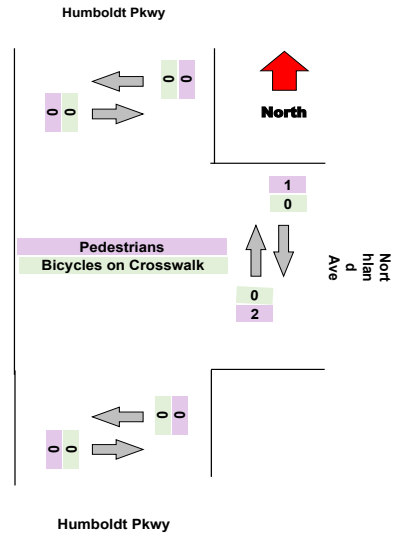
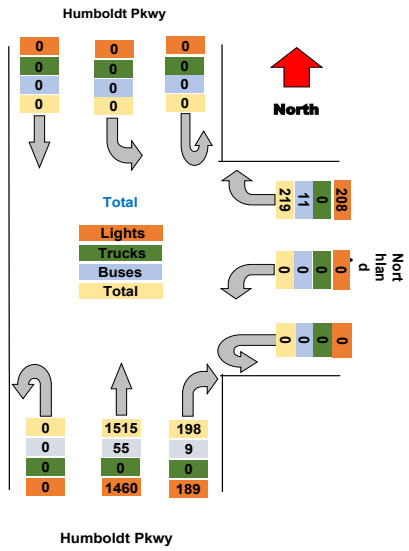

Turning Movement Peak Hour Data (AM)
 7:30:00 AM

Leg Direction	Humboldt Pkwy Southbound						Northland Ave Westbound						Humboldt Pkwy Northbound						Total
	Thru	Left	U-Turn	App Total	Peds CW	Peds CCW	Right	Left	U-Turn	App Total	Peds CW	Peds CCW	Right	Thru	U-Turn	App Total	Peds CW	Peds CCW	
7:30:00 AM	0	0	0	0	0	0	10	0	0	10	1	0	10	106	0	117	0	0	127
7:45:00 AM	0	0	0	0	0	0	9	0	0	9	0	1	22	86	0	109	0	0	118
8:00:00 AM	0	0	0	0	0	0	11	0	0	11	0	0	13	97	0	110	0	0	121
8:15:00 AM	0	0	0	0	0	0	12	0	0	12	0	0	11	90	0	101	0	0	113
Grand Total	0	0	0	0	0	0	42	0	0	42	1	1	56	379	0	437	0	0	479
% Approach	#####	#####	#####	0.0%	0.0%	0.0%	14.2%	0.0%	0.0%	0.0%	0.0%	0.0%	45.1%	41.7%	0.0%	0.0%	0.0%	0.0%	
% Total	0.0%	0.0%	0.0%	0.0%	0.0%	0.0%	8.8%	0.0%	0.0%	8.8%	0.0%	0.0%	11.7%	79.1%	0.0%	91.2%	0.0%	0.0%	
PHF	0.000	0.000	0.000	0.000	0.000	0.000	0.875	0.000	0.000	0.875	0.000	0.000	0.636	0.894	0.000	0.934	0.000	0.000	0.943
Lights	0	0	0	0	0	0	39	0	0	39	0	0	53	369	0	422	0	0	461
% Lights	0.0%	0.0%	0.0%	0.0%	0.0%	0.0%	92.9%	0.0%	0.0%	92.9%	0.0%	0.0%	94.6%	97.4%	0.0%	96.6%	0.0%	0.0%	96.2%
Trucks	0	0	0	0	0	0	0	0	0	0	0	0	0	0	0	0	0	0	0
% Trucks	0.0%	0.0%	0.0%	0.0%	0.0%	0.0%	0.0%	0.0%	0.0%	0.0%	0.0%	0.0%	0.0%	0.0%	0.0%	0.0%	0.0%	0.0%	0.0%
Buses	0	0	0	0	0	0	3	0	0	3	0	0	3	10	0	13	0	0	16
% Buses	0.0%	0.0%	0.0%	0.0%	0.0%	0.0%	7.1%	0.0%	0.0%	0.0%	0.0%	0.0%	5.4%	2.6%	0.0%	0.0%	0.0%	0.0%	3.3%
Pedestrians	0	0	0	0	0	0	0	0	0	0	1	1	0	0	0	0	0	0	0
% Pedestrians	0.0%	0.0%	0.0%	0.0%	0.0%	0.0%	0.0%	0.0%	0.0%	0.0%	100.0%	100.0%	0.0%	0.0%	0.0%	0.0%	0.0%	0.0%	0.0%
Bicycles on Crosswalk	0	0	0	0	0	0	0	0	0	0	0	0	0	0	0	0	0	0	0
% Bicycles on Crosswalk	0.0%	0.0%	0.0%	0.0%	0.0%	0.0%	0.0%	0.0%	0.0%	0.0%	0.0%	0.0%	0.0%	0.0%	0.0%	0.0%	0.0%	0.0%	0.0%

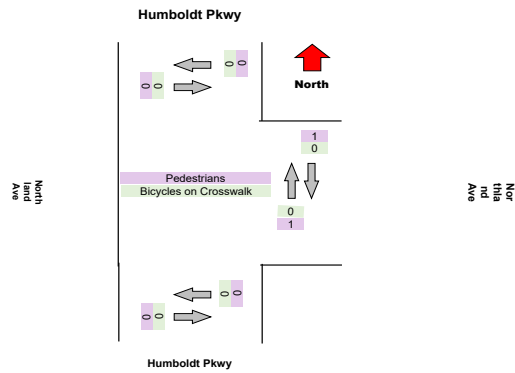
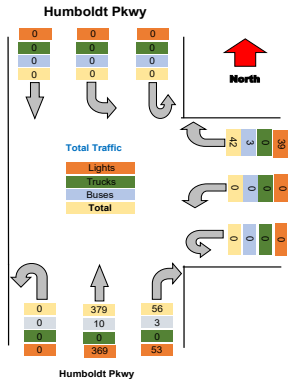

Turning Movement Peak Hour Data (PM)
 4:30:00 PM

Leg Direction	Humboldt Pkwy Southbound						Northland Ave Westbound						Humboldt Pkwy Northbound						Total
	Thru	Left	U-Turn	App Total	Peds CW	Peds CCW	Right	Left	U-Turn	App Total	Peds CW	Peds CCW	Right	Thru	U-Turn	App Total	Peds CW	Peds CCW	
4:30:00 PM	0	0	0	0	0	0	17	0	0	17	0	0	14	106	0	120	0	0	137
4:45:00 PM	0	0	0	0	0	0	21	0	0	21	0	0	19	86	0	105	0	0	126
5:00:00 PM	0	0	0	0	0	0	19	0	0	19	0	0	12	108	0	120	0	0	139
5:15:00 PM	0	0	0	0	0	0	21	0	0	21	0	0	16	115	0	131	0	0	152
Grand Total	0	0	0	0	0	0	78	0	0	78	0	0	61	415	0	476	0	0	554
% Approach	#####	#####	#####	0.0%	0.0%	0.0%	14.2%	0.0%	0.0%	0.0%	0.0%	0.0%	45.1%	41.7%	0.0%	0.0%	0.0%	0.0%	
% Total	0.0%	0.0%	0.0%	0.0%	0.0%	0.0%	14.1%	0.0%	0.0%	14.1%	0.0%	0.0%	11.0%	74.9%	0.0%	85.9%	0.0%	0.0%	
PHF	0.000	0.000	0.000	0.000	0.000	0.000	0.929	0.000	0.000	0.929	0.000	0.000	0.803	0.902	0.000	0.908	0.000	0.000	0.911
Lights	0	0	0	0	0	0	76	0	0	76	0	0	59	403	0	462	0	0	538
% Lights	0.0%	0.0%	0.0%	0.0%	0.0%	0.0%	97.4%	0.0%	0.0%	97.4%	0.0%	0.0%	96.7%	97.1%	0.0%	97.1%	0.0%	0.0%	97.1%
Trucks	0	0	0	0	0	0	0	0	0	0	0	0	0	0	0	0	0	0	0
% Trucks	0.0%	0.0%	0.0%	0.0%	0.0%	0.0%	0.0%	0.0%	0.0%	0.0%	0.0%	0.0%	0.0%	0.0%	0.0%	0.0%	0.0%	0.0%	0.0%
Buses	0	0	0	0	0	0	2	0	0	2	0	0	2	12	0	14	0	0	16
% Buses	0.0%	0.0%	0.0%	0.0%	0.0%	0.0%	2.6%	0.0%	0.0%	2.6%	0.0%	0.0%	3.3%	2.9%	0.0%	2.9%	0.0%	0.0%	2.9%
Pedestrians	0	0	0	0	0	0	0	0	0	0	0	0	0	0	0	0	0	0	0
% Pedestrians	0.0%	0.0%	0.0%	0.0%	0.0%	0.0%	0.0%	0.0%	0.0%	0.0%	0.0%	0.0%	0.0%	0.0%	0.0%	0.0%	0.0%	0.0%	0.0%
Bicycles on Crosswalk	0	0	0	0	0	0	0	0	0	0	0	0	0	0	0	0	0	0	0
% Bicycles on Crosswalk	0.0%	0.0%	0.0%	0.0%	0.0%	0.0%	0.0%	0.0%	0.0%	0.0%	0.0%	0.0%	0.0%	0.0%	0.0%	0.0%	0.0%	0.0%	0.0%

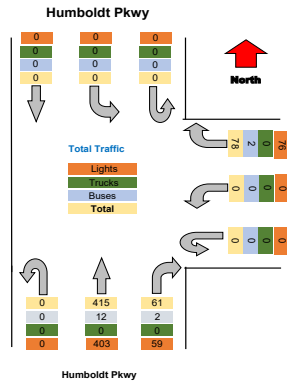

Northland Ave

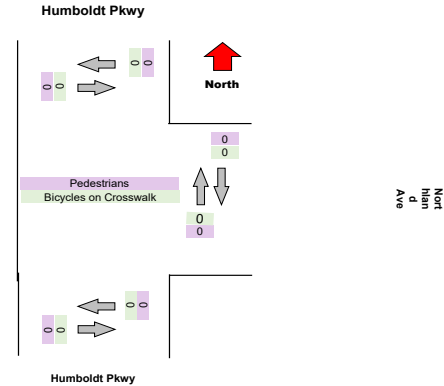

Northland Ave

Turning Movement Data Plot

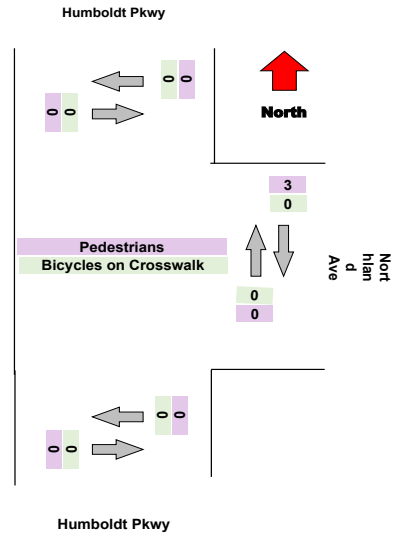
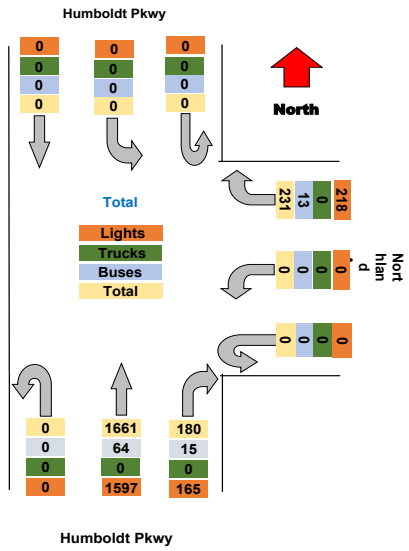

Intersection: Elm St Pine St
 Location: Kennett Square, PA
 Site: 01
 Survey Date: Wednesday, 04-28-2021
 GPS: 42.948550, -72.790034



Turning Movement Peak Hour Data (AM)
 7:30:00 AM

Leg Direction	Humboldt Pkwy Southbound						Northland Ave Westbound						Humboldt Pkwy Northbound						Total				
	Thru	Left	U-Turn	App	Total	Peds CW	Peds CCW	Right	Left	U-Turn	App	Total	Peds CW	Peds CCW	Right	Thru	U-Turn	App		Total	Peds CW	Peds CCW	
7:30:00 AM	0	0	0	0	0	0	0	15	0	0	15	3	0	0	13	103	0	119	0	0	0	0	134
7:45:00 AM	0	0	0	0	0	0	0	14	0	0	14	0	0	0	19	91	0	110	0	0	0	0	124
8:00:00 AM	0	0	0	0	0	0	0	14	0	0	14	0	0	0	14	103	0	117	0	0	0	0	131
8:15:00 AM	0	0	0	0	0	0	0	7	0	0	7	0	0	0	5	71	0	76	0	0	0	0	83
Grand Total	0	0	0	0	0	0	0	50	0	0	50	3	0	0	51	368	0	422	0	0	0	0	472
% Approach	#####	#####	#####	0.0%	0.0%	0.0%	0.0%	14.2%	0.0%	0.0%	10.6%	0.0%	0.0%	0.0%	45.1%	41.7%	0.0%	0.0%	0.0%	0.0%	0.0%	0.0%	0.0%
% Total	0.0%	0.0%	0.0%	0.0%	0.0%	0.0%	0.0%	10.6%	0.0%	0.0%	10.6%	0.0%	0.0%	0.0%	10.8%	78.0%	0.0%	89.4%	0.0%	0.0%	0.0%	0.0%	0.0%
PHF	0.000	0.000	0.000	0.000	0.000	0.000	0.000	0.833	0.000	0.000	0.833	0.000	0.000	0.000	0.671	0.893	0.000	0.887	0.000	0.000	0.000	0.000	0.881
Lights	0	0	0	0	0	0	0	47	0	0	47	0	0	0	48	357	0	405	0	0	0	0	452
% Lights	0.0%	0.0%	0.0%	0.0%	0.0%	0.0%	0.0%	94.0%	0.0%	0.0%	94.0%	0.0%	0.0%	0.0%	94.1%	97.0%	0.0%	96.0%	0.0%	0.0%	0.0%	0.0%	95.8%
Trucks	0	0	0	0	0	0	0	0	0	0	0	0	0	0	0	0	0	0	0	0	0	0	0
% Trucks	0.0%	0.0%	0.0%	0.0%	0.0%	0.0%	0.0%	0.0%	0.0%	0.0%	0.0%	0.0%	0.0%	0.0%	0.0%	0.0%	0.0%	0.0%	0.0%	0.0%	0.0%	0.0%	0.0%
Buses	0	0	0	0	0	0	0	3	0	0	3	0	0	0	3	11	0	14	0	0	0	0	17
% Buses	0.0%	0.0%	0.0%	0.0%	0.0%	0.0%	0.0%	6.0%	0.0%	0.0%	6.0%	0.0%	0.0%	0.0%	5.9%	3.0%	0.0%	3.3%	0.0%	0.0%	0.0%	0.0%	3.6%
Pedestrians	0	0	0	0	0	0	0	0	0	0	0	3	0	0	0	0	0	0	0	0	0	0	3
% Pedestrians	0.0%	0.0%	0.0%	0.0%	0.0%	0.0%	0.0%	0.0%	0.0%	0.0%	0.0%	100.0%	0.0%	0.0%	0.0%	0.0%	0.0%	0.0%	0.0%	0.0%	0.0%	0.0%	0.0%
Bicycles on Crosswalk	0	0	0	0	0	0	0	0	0	0	0	0	0	0	0	0	0	0	0	0	0	0	0
% Bicycles on Crosswalk	0.0%	0.0%	0.0%	0.0%	0.0%	0.0%	0.0%	0.0%	0.0%	0.0%	0.0%	0.0%	0.0%	0.0%	0.0%	0.0%	0.0%	0.0%	0.0%	0.0%	0.0%	0.0%	0.0%

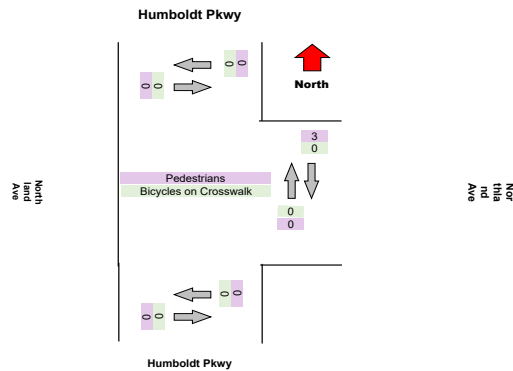
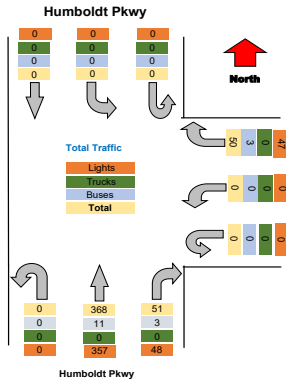

Turning Movement Peak Hour Data (PM)
 4:30:00 PM

Leg Direction	Humboldt Pkwy						Northland Ave						Humboldt Pkwy						Total
	Thru	Left	U-Turn	App Total	Peds CW	Peds CCW	Right	Left	U-Turn	App Total	Peds CW	Peds CCW	Right	Thru	U-Turn	App Total	Peds CW	Peds CCW	
4:30:00 PM	0	0	0	0	0	0	15	0	0	15	0	0	15	145	0	160	0	0	175
4:45:00 PM	0	0	0	0	0	0	18	0	0	18	0	0	9	125	0	134	0	0	152
5:00:00 PM	0	0	0	0	0	0	18	0	0	18	0	0	13	116	0	129	0	0	147
5:15:00 PM	0	0	0	0	0	0	16	0	0	16	0	0	6	137	0	143	0	0	159
Grand Total	0	0	0	0	0	0	67	0	0	67	0	0	43	523	0	566	0	0	633
% Approach	#####	#####	#####	0.0%	0.0%	0.0%	14.2%	0.0%	0.0%	0.0%	0.0%	0.0%	45.1%	41.7%	0.0%	0.0%	0.0%	0.0%	
% Total	0.0%	0.0%	0.0%	0.0%	0.0%	0.0%	10.6%	0.0%	0.0%	10.6%	0.0%	0.0%	6.8%	82.6%	0.0%	89.4%	0.0%	0.0%	
PHF	0.000	0.000	0.000	0.000	0.000	0.000	0.931	0.000	0.000	0.931	0.000	0.000	0.717	0.902	0.000	0.884	0.000	0.000	0.904
Lights	0	0	0	0	0	0	67	0	0	67	0	0	38	509	0	547	0	0	614
% Lights	0.0%	0.0%	0.0%	0.0%	0.0%	0.0%	100.0%	0.0%	0.0%	100.0%	0.0%	0.0%	88.4%	97.3%	0.0%	96.6%	0.0%	0.0%	97.0%
Trucks	0	0	0	0	0	0	0	0	0	0	0	0	0	0	0	0	0	0	0
% Trucks	0.0%	0.0%	0.0%	0.0%	0.0%	0.0%	0.0%	0.0%	0.0%	0.0%	0.0%	0.0%	0.0%	0.0%	0.0%	0.0%	0.0%	0.0%	0.0%
Buses	0	0	0	0	0	0	0	0	0	0	0	0	5	14	0	19	0	0	19
% Buses	0.0%	0.0%	0.0%	0.0%	0.0%	0.0%	0.0%	0.0%	0.0%	0.0%	0.0%	0.0%	11.6%	2.7%	0.0%	0.0%	0.0%	0.0%	3.0%
Pedestrians	0	0	0	0	0	0	0	0	0	0	0	0	0	0	0	0	0	0	0
% Pedestrians	0.0%	0.0%	0.0%	0.0%	0.0%	0.0%	0.0%	0.0%	0.0%	0.0%	0.0%	0.0%	0.0%	0.0%	0.0%	0.0%	0.0%	0.0%	0.0%
Bicycles on Crosswalk	0	0	0	0	0	0	0	0	0	0	0	0	0	0	0	0	0	0	0
% Bicycles on Crosswalk	0.0%	0.0%	0.0%	0.0%	0.0%	0.0%	0.0%	0.0%	0.0%	0.0%	0.0%	0.0%	0.0%	0.0%	0.0%	0.0%	0.0%	0.0%	0.0%

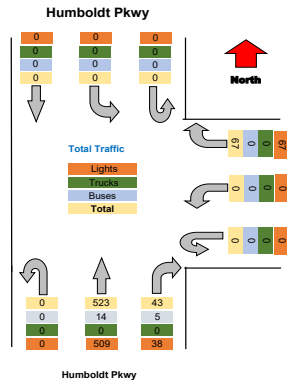

North
Northland Ave

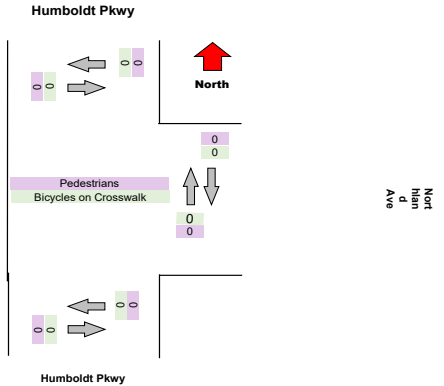

North
Northland Ave

Turning Movement Data Plot

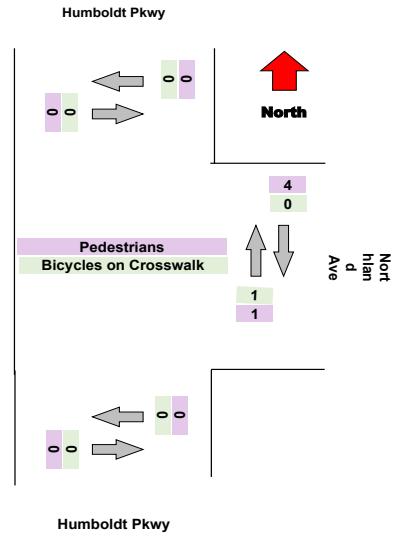
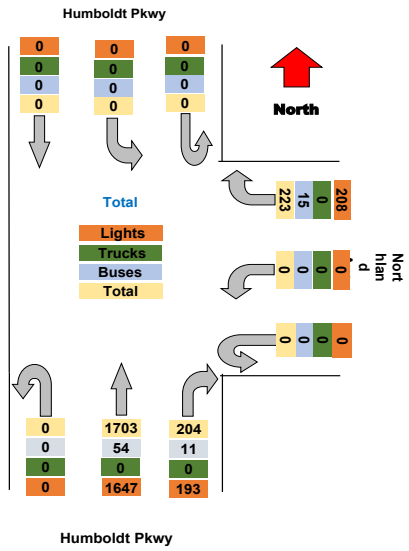

Turning Movement Peak Hour Data (AM)
 7:30:00 AM

Leg Direction	Humboldt Pkwy Southbound						Northland Ave Westbound						Humboldt Pkwy Northbound						Total
	Thru	Left	U-Turn	App Total	Peds CW	Peds CCW	Right	Left	U-Turn	App Total	Peds CW	Peds CCW	Right	Thru	U-Turn	App Total	Peds CW	Peds CCW	
7:30:00 AM	0	0	0	0	0	0	17	0	0	17	3	0	12	106	0	121	0	0	138
7:45:00 AM	0	0	0	0	0	0	16	0	0	16	0	0	20	116	0	136	0	0	152
8:00:00 AM	0	0	0	0	0	0	12	0	0	12	0	0	8	107	0	115	0	0	127
8:15:00 AM	0	0	0	0	0	0	9	0	0	9	0	0	14	78	0	92	0	0	101
Grand Total	0	0	0	0	0	0	54	0	0	54	3	0	54	407	0	464	0	0	518
% Approach	#####	#####	#####	0.0%	0.0%	0.0%	14.2%	0.0%	0.0%	0.0%	0.0%	0.0%	45.1%	41.7%	0.0%	0.0%	0.0%	0.0%	
% Total	0.0%	0.0%	0.0%	0.0%	0.0%	0.0%	10.4%	0.0%	0.0%	10.4%	0.0%	0.0%	10.4%	78.6%	0.0%	89.6%	0.0%	0.0%	
PHF	0.000	0.000	0.000	0.000	0.000	0.000	0.794	0.000	0.000	0.794	0.000	0.000	0.675	0.877	0.000	0.853	0.000	0.000	0.852
Lights	0	0	0	0	0	0	50	0	0	50	0	0	51	397	0	448	0	0	498
% Lights	0.0%	0.0%	0.0%	0.0%	0.0%	0.0%	92.6%	0.0%	0.0%	92.6%	0.0%	0.0%	94.4%	97.5%	0.0%	96.6%	0.0%	0.0%	96.1%
Trucks	0	0	0	0	0	0	0	0	0	0	0	0	0	0	0	0	0	0	0
% Trucks	0.0%	0.0%	0.0%	0.0%	0.0%	0.0%	0.0%	0.0%	0.0%	0.0%	0.0%	0.0%	0.0%	0.0%	0.0%	0.0%	0.0%	0.0%	0.0%
Buses	0	0	0	0	0	0	4	0	0	4	0	0	3	10	0	13	0	0	17
% Buses	0.0%	0.0%	0.0%	0.0%	0.0%	0.0%	7.4%	0.0%	0.0%	0.0%	0.0%	0.0%	5.6%	2.5%	0.0%	0.0%	0.0%	0.0%	3.3%
Pedestrians	0	0	0	0	0	0	0	0	0	0	3	0	0	0	0	0	0	0	0
% Pedestrians	0.0%	0.0%	0.0%	0.0%	0.0%	0.0%	0.0%	0.0%	0.0%	0.0%	100.0%	0.0%	0.0%	0.0%	0.0%	0.0%	0.0%	0.0%	0.0%
Bicycles on Crosswalk	0	0	0	0	0	0	0	0	0	0	0	0	0	0	0	0	0	0	0
% Bicycles on Crosswalk	0.0%	0.0%	0.0%	0.0%	0.0%	0.0%	0.0%	0.0%	0.0%	0.0%	0.0%	0.0%	0.0%	0.0%	0.0%	0.0%	0.0%	0.0%	0.0%

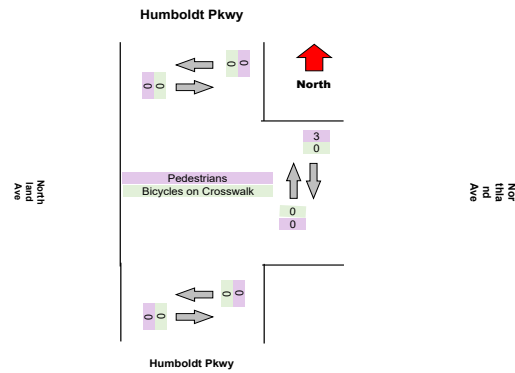
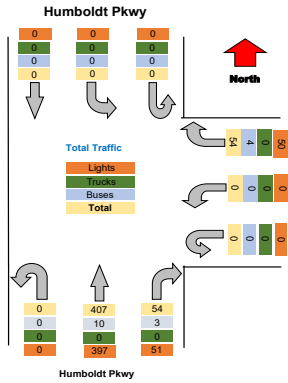

Turning Movement Peak Hour Data (PM)
 4:30:00 PM

Leg Direction	Humboldt Pkwy						Northland Ave						Humboldt Pkwy						Total
	Southbound			Westbound			Northbound			Northbound									
Start Time	Thru	Left	U-Turn	App Total	Peds CW	Peds CCW	Right	Left	U-Turn	App Total	Peds CW	Peds CCW	Right	Thru	U-Turn	App Total	Peds CW	Peds CCW	
4:30:00 PM	0	0	0	0	0	0	15	0	0	15	0	0	14	116	0	130	0	0	145
4:45:00 PM	0	0	0	0	0	0	9	0	0	9	0	0	17	119	0	136	0	0	145
5:00:00 PM	0	0	0	0	0	0	21	0	0	21	0	0	21	138	0	159	0	0	180
5:15:00 PM	0	0	0	0	0	0	11	0	0	11	0	1	8	126	0	134	0	0	145
Grand Total	0	0	0	0	0	0	56	0	0	56	0	1	60	499	0	559	0	0	615
% Approach	#####	#####	#####	0.0%	0.0%	0.0%	14.2%	0.0%	0.0%	0.0%	0.0%	0.0%	45.1%	41.7%	0.0%	0.0%	0.0%	0.0%	
% Total	0.0%	0.0%	0.0%	0.0%	0.0%	0.0%	9.1%	0.0%	0.0%	9.1%	0.0%	0.0%	9.8%	81.1%	0.0%	90.9%	0.0%	0.0%	
PHF	0.000	0.000	0.000	0.000	0.000	0.000	0.667	0.000	0.000	0.667	0.000	0.000	0.714	0.904	0.000	0.879	0.000	0.000	0.854
Lights	0	0	0	0	0	0	56	0	0	56	0	0	55	493	0	548	0	0	604
% Lights	0.0%	0.0%	0.0%	0.0%	0.0%	0.0%	100.0%	0.0%	0.0%	100.0%	0.0%	0.0%	91.7%	98.8%	0.0%	98.0%	0.0%	0.0%	98.2%
Trucks	0	0	0	0	0	0	0	0	0	0	0	0	0	0	0	0	0	0	0
% Trucks	0.0%	0.0%	0.0%	0.0%	0.0%	0.0%	0.0%	0.0%	0.0%	0.0%	0.0%	0.0%	0.0%	0.0%	0.0%	0.0%	0.0%	0.0%	0.0%
Buses	0	0	0	0	0	0	0	0	0	0	0	0	5	6	0	11	0	0	11
% Buses	0.0%	0.0%	0.0%	0.0%	0.0%	0.0%	0.0%	0.0%	0.0%	0.0%	0.0%	0.0%	8.3%	1.2%	0.0%	0.0%	0.0%	0.0%	1.8%
Pedestrians	0	0	0	0	0	0	0	0	0	0	0	0	0	0	0	0	0	0	0
% Pedestrians	0.0%	0.0%	0.0%	0.0%	0.0%	0.0%	0.0%	0.0%	0.0%	0.0%	0.0%	0.0%	0.0%	0.0%	0.0%	0.0%	0.0%	0.0%	0.0%
Bicycles on Crosswalk	0	0	0	0	0	0	0	0	0	0	0	1	0	0	0	0	0	0	0
% Bicycles on Crosswalk	0.0%	0.0%	0.0%	0.0%	0.0%	0.0%	0.0%	0.0%	0.0%	0.0%	0.0%	100.0%	0.0%	0.0%	0.0%	0.0%	0.0%	0.0%	0.0%

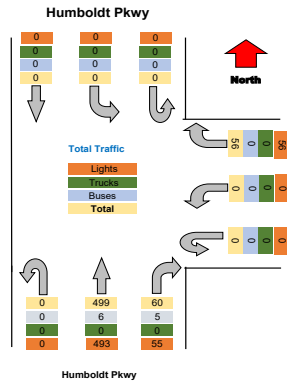

North
Northland Ave

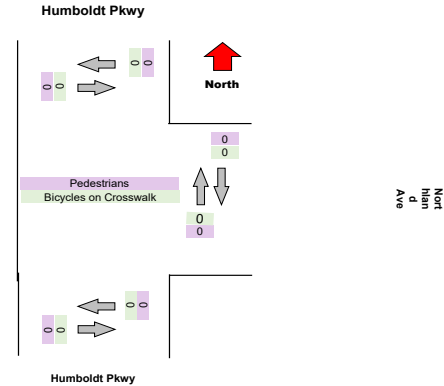

North
Northland Ave

Turning Movement Data Plot

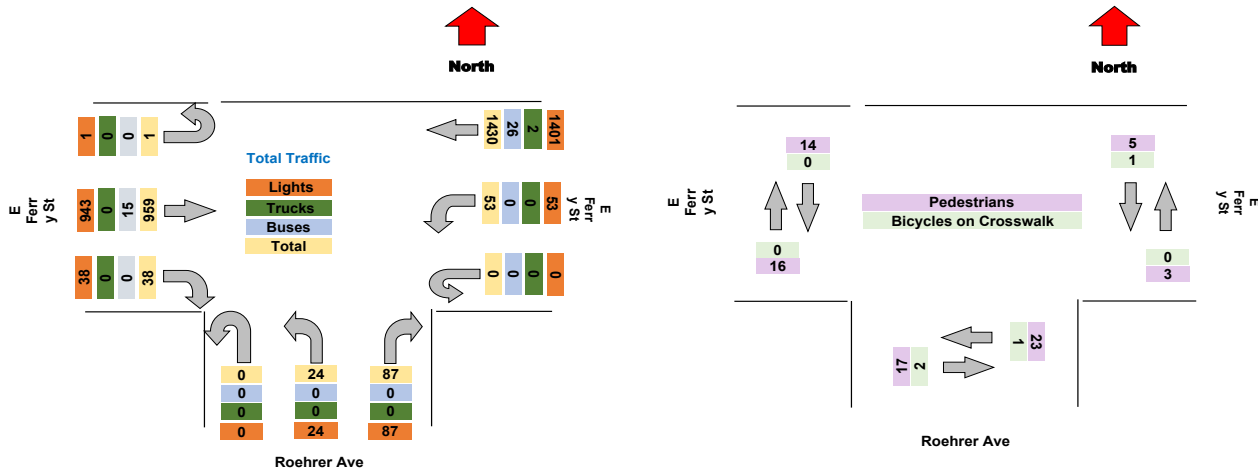

Turning Movement Peak Hour Data (AM)
7:30:00 AM

Leg Direction	E Ferry St Westbound						Roehrer Ave Northbound						E Ferry St Eastbound						Total
	Thru	Left	U-Turn	App Total	Peds CW	Peds CCW	Right	Left	U-Turn	App Total	Peds CW	Peds CCW	Right	Thru	U-Turn	App Total	Peds CW	Peds CCW	
7:30:00 AM	73	1	0	74	0	0	2	0	0	2	0	0	0	37	0	37	0	0	113
7:45:00 AM	117	1	0	118	0	0	1	0	0	1	0	0	0	43	0	43	0	0	162
8:00:00 AM	100	3	0	103	0	0	1	1	0	2	0	0	0	42	0	42	0	0	147
8:15:00 AM	78	0	0	78	0	0	5	0	0	5	0	0	0	49	0	49	0	0	132
Grand Total	368	5	0	373	0	0	9	1	0	10	0	0	0	171	0	171	0	0	554
% Approach	98.7%	1.3%	0.0%	0.0%	0.0%	0.0%	90.0%	10.0%	0.0%	0.0%	0.0%	0.0%	0.0%	#####	0.0%	0.0%	0.0%	0.0%	
% Total	66.4%	0.9%	0.0%	67.3%	0.0%	0.0%	1.6%	0.2%	0.0%	1.8%	0.0%	0.0%	0.0%	30.9%	0.0%	30.9%	0.0%	0.0%	
PHF	0.786	0.417	0.000	0.790	0.000	0.000	0.450	0.250	0.000	0.500	0.000	0.000	0.000	0.872	0.000	0.872	0.000	0.000	0.855
Lights	360	5	0	365	0	0	9	1	0	10	0	0	0	168	0	168	0	0	543
% Lights	97.8%	100.0%	0.0%	97.9%	0.0%	0.0%	100.0%	100.0%	0.0%	100.0%	0.0%	0.0%	0.0%	98.2%	0.0%	98.2%	0.0%	0.0%	98.0%
Trucks	1	0	0	1	0	0	0	0	0	0	0	0	0	0	0	0	0	0	1
% Trucks	0.3%	0.0%	0.0%	0.3%	0.0%	0.0%	0.0%	0.0%	0.0%	0.0%	0.0%	0.0%	0.0%	0.0%	0.0%	0.0%	0.0%	0.0%	0.2%
Buses	6	0	0	6	0	0	0	0	0	0	0	0	0	3	0	3	0	0	9
% Buses	1.6%	0.0%	0.0%	0.0%	0.0%	0.0%	0.0%	0.0%	0.0%	0.0%	0.0%	0.0%	0.0%	1.8%	0.0%	0.0%	0.0%	0.0%	1.6%
Pedestrians	0	0	0	0	0	0	0	0	0	0	0	0	0	0	0	0	0	0	0
% Pedestrians	0.0%	0.0%	0.0%	0.0%	0.0%	0.0%	0.0%	0.0%	0.0%	0.0%	0.0%	0.0%	0.0%	0.0%	0.0%	0.0%	0.0%	0.0%	0.0%
Bicycles on Crosswalk	0	0	0	0	0	0	0	0	0	0	0	0	0	0	0	0	0	0	0
% Bicycles on Crosswalk	0.0%	0.0%	0.0%	0.0%	0.0%	0.0%	0.0%	0.0%	0.0%	0.0%	0.0%	0.0%	0.0%	0.0%	0.0%	0.0%	0.0%	0.0%	0.0%

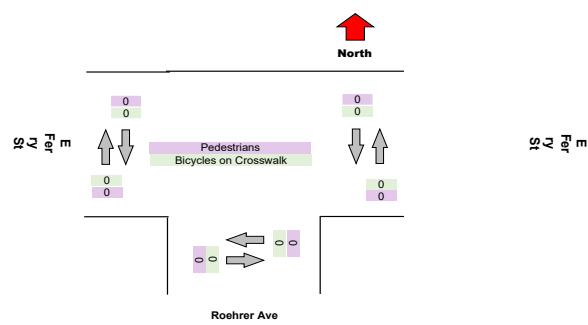
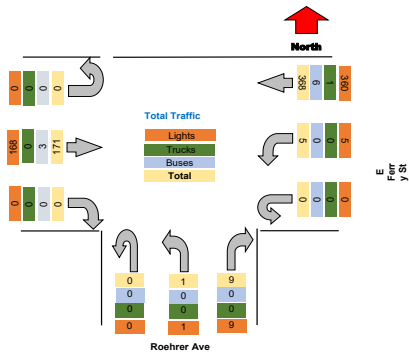

Turning Movement Peak Hour Data (PM)

4:30:00 PM

Leg Direction	E Ferry St Westbound						Roehrer Ave Northbound						E Ferry St Eastbound						Total
	Thru	Left	U-Turn	App Total	Peds CW	Peds CCW	Right	Left	U-Turn	App Total	Peds CW	Peds CCW	Right	Thru	U-Turn	App Total	Peds CW	Peds CCW	
4:30:00 PM	105	6	0	111	0	0	6	2	0	8	3	1	4	85	0	89	1	2	208
4:45:00 PM	97	5	0	102	1	0	6	5	0	11	3	2	6	83	0	89	3	1	202
5:00:00 PM	91	3	0	94	1	1	18	5	0	23	2	2	2	93	1	96	2	1	213
5:15:00 PM	131	3	0	134	3	0	11	3	0	14	6	5	4	88	0	92	2	2	240
Grand Total	424	17	0	441	5	1	41	15	0	56	14	10	16	349	1	366	8	6	863
% Approach	96.1%	3.9%	0.0%	0.0%	0.0%	0.0%	73.2%	26.8%	0.0%	0.0%	0.0%	0.0%	4.4%	95.4%	0.3%	0.0%	0.0%	0.0%	
% Total	49.1%	2.0%	0.0%	51.1%	0.0%	0.0%	4.8%	1.7%	0.0%	6.5%	0.0%	0.0%	1.9%	40.4%	0.1%	42.4%	0.0%	0.0%	
PHF	0.809	0.708	0.000	0.823	0.000	0.000	0.569	0.750	0.000	0.609	0.000	0.000	0.667	0.938	0.250	0.953	0.000	0.000	0.899
Lights	418	17	0	435	0	0	41	15	0	56	0	0	16	344	1	361	0	0	852
% Lights	98.6%	100.0%	0.0%	98.6%	0.0%	0.0%	100.0%	100.0%	0.0%	100.0%	0.0%	0.0%	100.0%	98.6%	100.0%	98.6%	0.0%	0.0%	98.7%
Trucks	1	0	0	1	0	0	0	0	0	0	0	0	0	0	0	0	0	0	1
% Trucks	0.2%	0.0%	0.0%	0.2%	0.0%	0.0%	0.0%	0.0%	0.0%	0.0%	0.0%	0.0%	0.0%	0.0%	0.0%	0.0%	0.0%	0.0%	0.1%
Buses	5	0	0	5	0	0	0	0	0	0	0	0	0	5	0	5	0	0	10
% Buses	1.2%	0.0%	0.0%	0.0%	0.0%	0.0%	0.0%	0.0%	0.0%	0.0%	0.0%	0.0%	0.0%	1.4%	0.0%	0.0%	0.0%	0.0%	1.2%
Pedestrians	0	0	0	0	4	1	0	0	0	0	13	9	0	0	0	8	6	0	0
% Pedestrians	0.0%	0.0%	0.0%	0.0%	80.0%	100.0%	0.0%	0.0%	0.0%	0.0%	92.9%	90.0%	0.0%	0.0%	0.0%	0.0%	100.0%	100.0%	0.0%
Bicycles on Crosswalk	0	0	0	0	1	0	0	0	0	1	1	0	0	0	0	0	0	0	0
% Bicycles on Crosswalk	0.0%	0.0%	0.0%	0.0%	20.0%	0.0%	0.0%	0.0%	0.0%	7.1%	10.0%	0.0%	0.0%	0.0%	0.0%	0.0%	0.0%	0.0%	0.0%

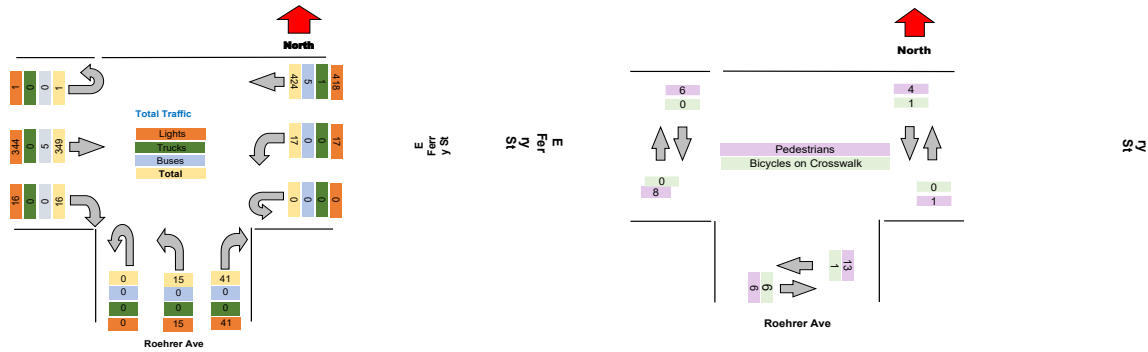

Turning Movement Data Plot

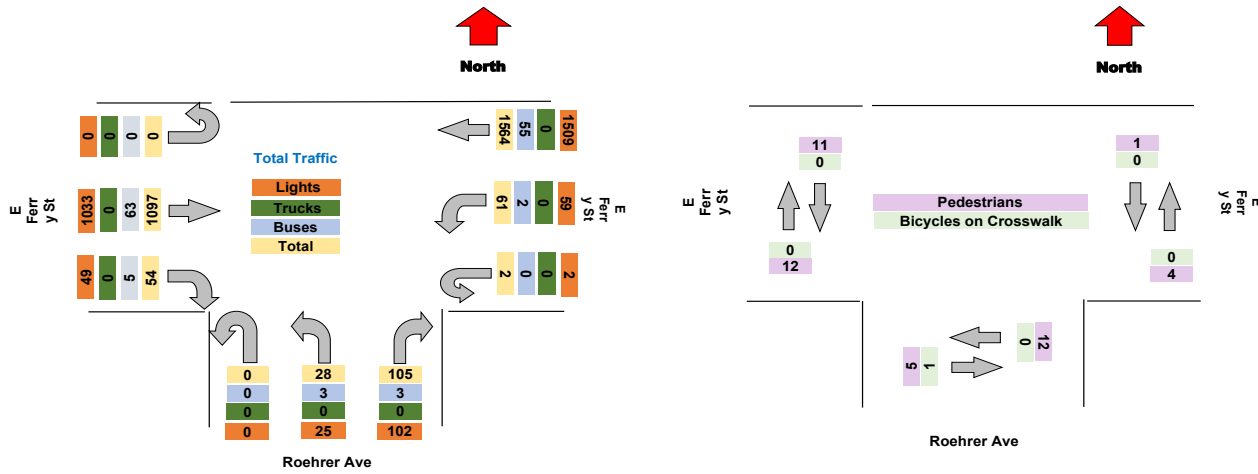

Turning Movement Peak Hour Data (AM)

7:30:00 AM

Leg Direction	E Ferry St Westbound						Roehrer Ave Northbound						E Ferry St Eastbound						Total
	Thru	Left	U-Turn	App Total	Peds CW	Peds CCW	Right	Left	U-Turn	App Total	Peds CW	Peds CCW	Right	Thru	U-Turn	App Total	Peds CW	Peds CCW	
7:30:00 AM	123	3	0	126	0	0	3	0	0	3	0	0	1	65	0	66	0	0	195
7:45:00 AM	146	2	0	148	0	2	5	0	0	3	1	0	4	77	0	82	0	0	237
8:00:00 AM	117	7	0	124	0	0	2	1	0	7	0	0	2	60	0	62	0	0	189
8:15:00 AM	82	6	0	88	0	0	1	0	0	1	0	0	2	53	0	55	0	0	144
Grand Total	468	18	0	486	0	2	11	1	0	14	1	0	9	255	0	265	0	0	765
% Approach	96.3%	3.7%	0.0%	0.0%	0.0%	0.0%	78.6%	7.1%	0.0%	0.0%	0.0%	0.0%	3.4%	96.2%	0.0%	0.0%	0.0%	0.0%	
% Total	61.2%	2.4%	0.0%	63.5%	0.0%	0.0%	1.4%	0.1%	0.0%	1.8%	0.0%	0.0%	1.2%	33.3%	0.0%	34.6%	0.0%	0.0%	
PHF	0.801	0.643	0.000	0.821	0.000	0.000	0.550	0.250	0.000	0.500	0.000	0.000	0.563	0.828	0.000	0.808	0.000	0.000	0.807
Lights	448	16	0	464	0	0	11	0	0	11	0	0	8	229	0	237	0	0	712
% Lights	95.7%	88.9%	0.0%	95.5%	0.0%	0.0%	100.0%	0.0%	0.0%	78.6%	0.0%	0.0%	88.9%	89.8%	0.0%	89.4%	0.0%	0.0%	93.1%
Trucks	0	0	0	0	0	0	0	0	0	0	0	0	0	0	0	0	0	0	0
% Trucks	0.0%	0.0%	0.0%	0.0%	0.0%	0.0%	0.0%	0.0%	0.0%	0.0%	0.0%	0.0%	0.0%	0.0%	0.0%	0.0%	0.0%	0.0%	0.0%
Buses	20	2	0	22	0	0	0	1	0	1	0	0	1	26	0	27	0	0	50
% Buses	4.3%	11.1%	0.0%	0.0%	0.0%	0.0%	0.0%	100.0%	0.0%	0.0%	0.0%	0.0%	11.1%	10.2%	0.0%	0.0%	0.0%	0.0%	6.5%
Pedestrians	0	0	0	0	0	2	0	0	0	1	0	0	0	0	0	0	0	0	0
% Pedestrians	0.0%	0.0%	0.0%	0.0%	0.0%	100.0%	0.0%	0.0%	0.0%	0.0%	100.0%	0.0%	0.0%	0.0%	0.0%	0.0%	0.0%	0.0%	0.0%
Bicycles on Crosswalk	0	0	0	0	0	0	0	0	0	0	0	0	0	0	0	0	0	0	0
% Bicycles on Crosswalk	0.0%	0.0%	0.0%	0.0%	0.0%	0.0%	0.0%	0.0%	0.0%	0.0%	0.0%	0.0%	0.0%	0.0%	0.0%	0.0%	0.0%	0.0%	0.0%

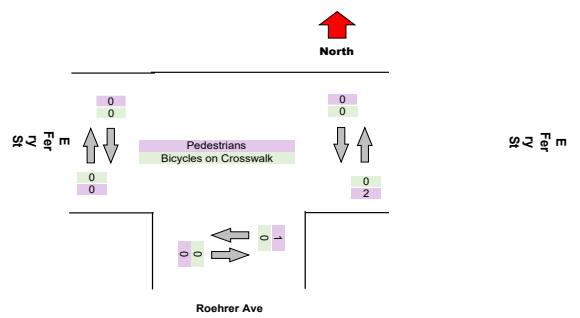
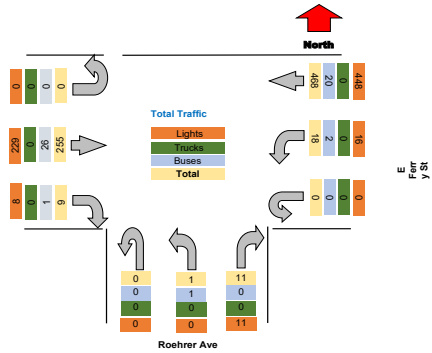

Turning Movement Peak Hour Data (PM)
4:30:00 PM

Leg Direction	E Ferry St Westbound						Roehrer Ave Northbound						E Ferry St Eastbound						Total
	Thru	Left	U-Turn	App Total	Peds CW	Peds CCW	Right	Left	U-Turn	App Total	Peds CW	Peds CCW	Right	Thru	U-Turn	App Total	Peds CW	Peds CCW	
4:30:00 PM	100	3	0	103	0	1	9	2	0	11	0	0	5	95	0	100	2	1	214
4:45:00 PM	98	2	2	102	0	0	8	4	0	12	3	1	7	83	0	90	1	1	204
5:00:00 PM	103	6	0	109	0	0	10	2	0	12	5	0	8	82	0	90	1	1	211
5:15:00 PM	123	2	0	125	0	0	10	5	0	15	0	1	7	90	0	97	0	1	237
Grand Total	424	13	2	439	0	1	37	13	0	50	8	2	27	350	0	377	4	4	866
% Approach	96.6%	3.0%	0.5%	0.0%	0.0%	0.0%	74.0%	26.0%	0.0%	0.0%	0.0%	0.0%	7.2%	92.8%	0.0%	0.0%	0.0%	0.0%	0.0%
% Total	49.0%	1.5%	0.2%	50.7%	0.0%	0.0%	4.3%	1.5%	0.0%	5.8%	0.0%	0.0%	3.1%	40.4%	0.0%	43.5%	0.0%	0.0%	0.0%
PHF	0.862	0.542	0.250	0.878	0.000	0.000	0.925	0.650	0.000	0.833	0.000	0.000	0.844	0.921	0.000	0.943	0.000	0.000	0.914
Lights	412	13	2	427	0	0	37	11	0	48	0	0	26	338	0	364	0	0	839
% Lights	97.2%	100.0%	100.0%	97.3%	0.0%	0.0%	100.0%	84.6%	0.0%	96.0%	0.0%	0.0%	96.3%	96.6%	0.0%	96.6%	0.0%	0.0%	96.9%
Trucks	0	0	0	0	0	0	0	0	0	0	0	0	0	0	0	0	0	0	0
% Trucks	0.0%	0.0%	0.0%	0.0%	0.0%	0.0%	0.0%	0.0%	0.0%	0.0%	0.0%	0.0%	0.0%	0.0%	0.0%	0.0%	0.0%	0.0%	0.0%
Buses	12	0	0	12	0	0	0	2	0	2	0	0	1	11	0	12	0	0	25
% Buses	2.8%	0.0%	0.0%	0.0%	0.0%	0.0%	0.0%	15.4%	0.0%	0.0%	0.0%	0.0%	3.7%	3.1%	0.0%	0.0%	0.0%	0.0%	3.0%
Pedestrians	0	0	0	0	0	1	0	0	0	0	8	1	0	0	0	0	4	4	0
% Pedestrians	0.0%	0.0%	0.0%	0.0%	0.0%	100.0%	0.0%	0.0%	0.0%	0.0%	100.0%	50.0%	0.0%	0.0%	0.0%	0.0%	100.0%	100.0%	0.0%
Bicycles on Crosswalk	0	0	0	0	0	0	0	0	0	0	1	0	0	0	0	0	0	0	0
% Bicycles on Crosswalk	0.0%	0.0%	0.0%	0.0%	0.0%	0.0%	0.0%	0.0%	0.0%	0.0%	50.0%	0.0%	0.0%	0.0%	0.0%	0.0%	0.0%	0.0%	0.0%

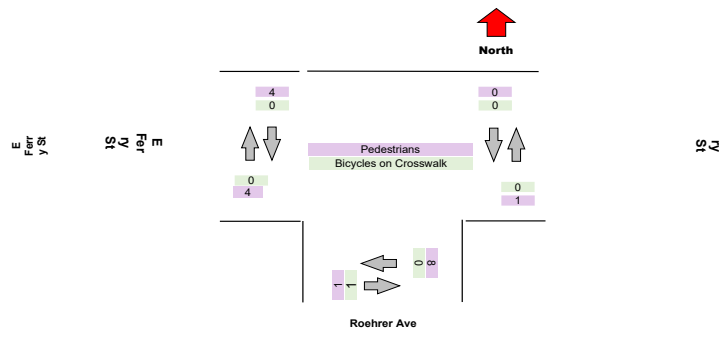
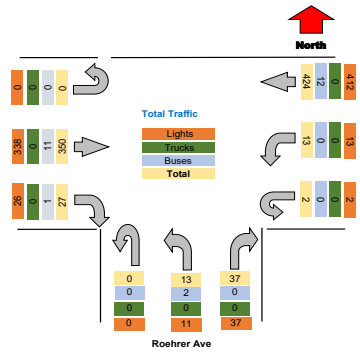



Project	LaBella
Project Code	LaBella
Site Name	P
Legs and Movements	All Processed Legs & Movements
Bin Size	15 minutes
Survey Date	2021-11-04, Thursday
Location	P
Latitude and Longitude	42.914738, -78.849126

	Start	End	PHF
Forced Peak AM	2021/11/04 07:30:00	2021/11/04 08:30:00	0.806
Forced Peak PM	2021/11/04 16:30:00	2021/11/04 17:30:00	0.922
AM Peak	2021/11/04 07:30:00	2021/11/04 08:30:00	0.806
PM Peak	2021/11/04 16:30:00	2021/11/04 17:30:00	0.922

Turning Movement Data

Leg Direction	E Ferry St Westbound					Roehrer Ave Northbound					E Ferry St Eastbound					Total
	Thru	Left	U-Turn	App Total	Peds CW/Peds CCW	Right	Left	U-Turn	App Total	Peds CW/Peds CCW	Right	Thru	U-Turn	App Total	Peds CW/Peds CCW	
Start Time																
6:30:00 AM	46	1	0	47	0	0	0	0	0	0	1	32	0	33	0	
6:45:00 AM	60	0	0	60	0	2	0	0	2	1	2	25	0	28	0	
Hourly Total	106	1	0	107	0	2	0	0	2	1	3	57	0	61	0	
7:00:00 AM	35	0	0	35	0	1	0	0	1	0	0	35	0	35	0	
7:15:00 AM	73	5	0	78	0	1	0	0	1	0	1	43	0	44	0	
7:30:00 AM	116	2	0	118	0	3	0	0	4	0	0	60	0	60	0	
7:45:00 AM	147	4	0	151	0	4	0	0	4	0	3	87	0	90	0	
Hourly Total	371	11	0	382	0	9	0	0	10	0	4	225	0	229	0	
8:00:00 AM	118	3	0	121	0	6	2	0	10	0	3	72	0	75	1	
8:15:00 AM	81	5	0	86	0	5	0	0	5	0	2	64	0	66	0	
Hourly Total	199	8	0	207	0	11	2	0	15	0	5	136	0	141	1	
4:00:00 PM	89	8	0	97	2	26	2	0	28	1	2	104	0	106	1	
4:15:00 PM	99	5	0	104	2	18	4	0	22	0	3	99	0	102	2	
4:30:00 PM	105	6	0	111	0	12	0	0	12	1	3	119	0	122	1	
4:45:00 PM	111	6	0	117	1	6	4	0	10	2	2	90	0	92	1	
Hourly Total	404	25	0	429	3	62	10	0	72	4	10	412	0	422	4	
5:00:00 PM	95	10	0	105	0	10	5	0	15	1	5	90	0	95	1	
5:15:00 PM	122	3	0	125	0	9	6	0	15	5	3	82	0	85	0	
5:30:00 PM	107	4	0	111	0	7	3	0	10	3	7	85	0	92	0	
5:45:00 PM	105	5	0	110	0	11	1	0	12	0	5	65	0	70	0	
Hourly Total	429	22	0	451	0	37	15	0	52	9	20	322	0	342	1	
Grand Total	1509	67	0	1576	5	121	27	0	151	14	42	1152	0	1195	7	
% Approach	95.7%	4.3%	0.0%	0.0%	0.0%	80.1%	17.9%	0.0%	0.0%	0.0%	3.5%	96.4%	0.0%	0.0%	0.0%	
% Total	51.6%	2.3%	0.0%	53.9%	0.0%	4.1%	0.9%	0.0%	5.2%	0.0%	1.4%	39.4%	0.0%	40.9%	0.0%	
Lights	1461	65	0	1526	0	119	26	0	145	0	41	1087	0	1128	0	
% Lights	96.8%	97.0%	0.0%	96.8%	0.0%	98.3%	96.3%	0.0%	96.0%	0.0%	97.6%	94.4%	0.0%	94.4%	0.0%	
Trucks	0	0	0	0	0	0	0	0	0	0	0	0	0	0	0	
% Trucks	0.0%	0.0%	0.0%	0.0%	0.0%	0.0%	0.0%	0.0%	0.0%	0.0%	0.0%	0.0%	0.0%	0.0%	0.0%	
Buses	48	2	0	50	0	2	1	0	3	0	1	65	0	66	0	
% Buses	3.2%	3.0%	0.0%	0.0%	0.0%	0.0%	3.7%	0.0%	0.0%	0.0%	2.4%	5.6%	0.0%	0.0%	0.0%	
Pedestrians	0	0	0	0	5	0	0	0	0	14	0	0	0	0	6	
% Pedestrians	0.0%	0.0%	0.0%	0.0%	100.0%	0.0%	0.0%	0.0%	0.0%	100.0%	0.0%	0.0%	0.0%	0.0%	100.0%	
Bicycles on Crosswalk	0	0	0	0	0	0	0	0	0	0	0	0	0	0	0	
% Bicycles on Crosswalk	0.0%	0.0%	0.0%	0.0%	0.0%	0.0%	0.0%	0.0%	0.0%	0.0%	0.0%	0.0%	0.0%	0.0%	0.0%	

Turning Movement Data Plot

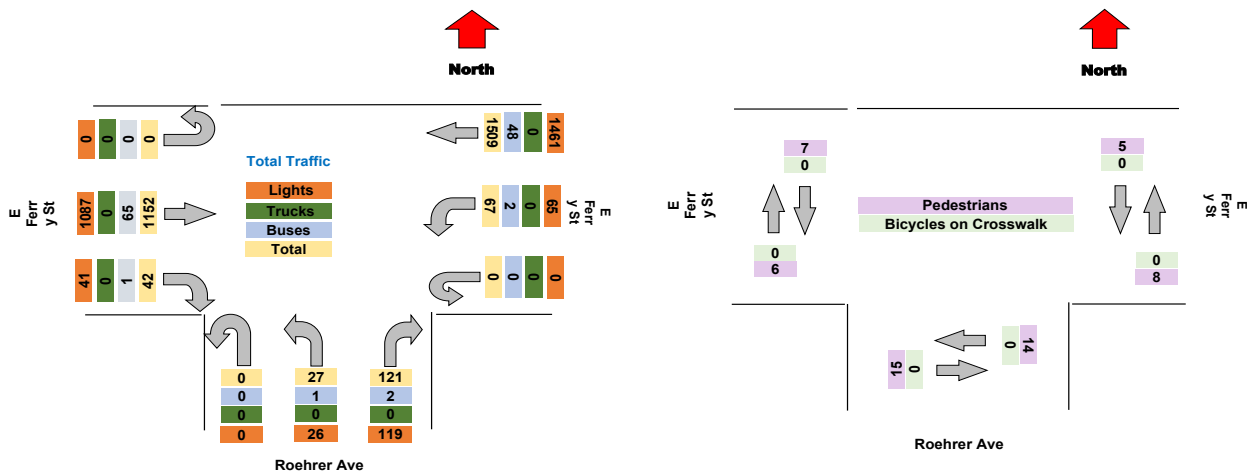

Turning Movement Peak Hour Data (AM)
7:30:00 AM

Leg Direction	E Ferry St Westbound						Roehrer Ave Northbound						E Ferry St Eastbound						Total	
	Thru	Left	U-Turn	App Total	Peds CW	Peds CCW	Right	Left	U-Turn	App Total	Peds CW	Peds CCW	Right	Thru	U-Turn	App Total	Peds CW	Peds CCW		
7:30:00 AM	116	2	0	118	0	1	3	0	0	4	0	0	0	60	0	0	60	0	0	182
7:45:00 AM	147	4	0	151	0	0	4	0	0	4	0	0	3	87	0	90	0	0	245	
8:00:00 AM	118	3	0	121	0	2	6	2	0	10	0	0	3	72	0	75	1	1	206	
8:15:00 AM	81	5	0	86	0	0	5	0	0	5	0	0	2	64	0	66	0	0	157	
Grand Total	462	14	0	476	0	3	18	2	0	23	0	0	8	283	0	291	1	1	790	
% Approach	97.1%	2.9%	0.0%	0.0%	0.0%	0.0%	78.3%	8.7%	0.0%	0.0%	0.0%	0.0%	2.7%	97.3%	0.0%	0.0%	0.0%	0.0%		
% Total	58.5%	1.8%	0.0%	60.3%	0.0%	0.0%	2.3%	0.3%	0.0%	2.9%	0.0%	0.0%	1.0%	35.8%	0.0%	36.8%	0.0%	0.0%		
PHF	0.786	0.700	0.000	0.788	0.000	0.000	0.750	0.250	0.000	0.575	0.000	0.000	0.667	0.813	0.000	0.808	0.000	0.000	0.806	
Lights	441	12	0	453	0	0	18	2	0	20	0	0	7	262	0	269	0	0	742	
% Lights	95.5%	85.7%	0.0%	95.2%	0.0%	0.0%	100.0%	100.0%	0.0%	87.0%	0.0%	0.0%	87.5%	92.6%	0.0%	92.4%	0.0%	0.0%	93.9%	
Trucks	0	0	0	0	0	0	0	0	0	0	0	0	0	0	0	0	0	0	0	
% Trucks	0.0%	0.0%	0.0%	0.0%	0.0%	0.0%	0.0%	0.0%	0.0%	0.0%	0.0%	0.0%	0.0%	0.0%	0.0%	0.0%	0.0%	0.0%	0.0%	
Buses	21	2	0	23	0	0	0	0	0	0	0	0	1	21	0	22	0	0	45	
% Buses	4.5%	14.3%	0.0%	0.0%	0.0%	0.0%	0.0%	0.0%	0.0%	0.0%	0.0%	0.0%	12.5%	7.4%	0.0%	0.0%	0.0%	0.0%	5.7%	
Pedestrians	0	0	0	0	0	3	0	0	0	0	0	0	0	0	0	0	1	1	0	
% Pedestrians	0.0%	0.0%	0.0%	0.0%	0.0%	100.0%	0.0%	0.0%	0.0%	0.0%	0.0%	0.0%	0.0%	0.0%	0.0%	0.0%	100.0%	100.0%	0.0%	
Bicycles on Crosswalk	0	0	0	0	0	0	0	0	0	0	0	0	0	0	0	0	0	0	0	
% Bicycles on Crosswalk	0.0%	0.0%	0.0%	0.0%	0.0%	0.0%	0.0%	0.0%	0.0%	0.0%	0.0%	0.0%	0.0%	0.0%	0.0%	0.0%	0.0%	0.0%	0.0%	

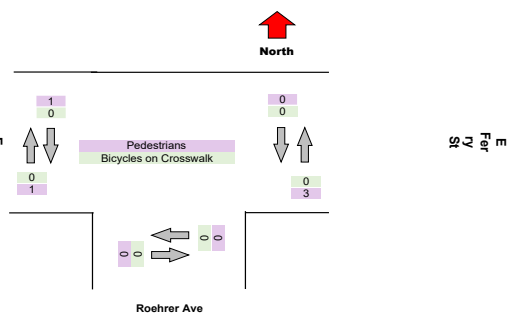
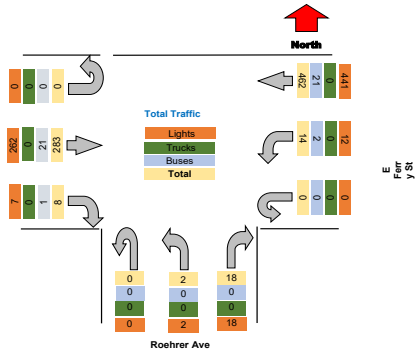

Turning Movement Peak Hour Data (PM)
4:30:00 PM

Leg Direction	E Ferry St Westbound						Roehrer Ave Northbound						E Ferry St Eastbound						Total
	Thru	Left	U-Turn	App Total	Peds CW	Peds CCW	Right	Left	U-Turn	App Total	Peds CW	Peds CCW	Right	Thru	U-Turn	App Total	Peds CW	Peds CCW	
4:30:00 PM	105	6	0	111	0	2	12	0	0	12	1	2	3	119	0	122	1	0	245
4:45:00 PM	111	6	0	117	1	1	6	4	0	10	2	3	2	90	0	92	0	1	219
5:00:00 PM	95	10	0	105	0	1	10	5	0	15	1	3	5	90	0	95	1	1	215
5:15:00 PM	122	3	0	125	0	0	9	6	0	15	5	2	3	82	0	85	0	1	225
Grand Total	433	25	0	458	1	4	37	15	0	52	9	10	13	381	0	394	2	3	904
% Approach	94.5%	5.5%	0.0%	0.0%	0.0%	0.0%	71.2%	28.8%	0.0%	0.0%	0.0%	0.0%	3.3%	96.7%	0.0%	0.0%	0.0%	0.0%	
% Total	47.9%	2.8%	0.0%	50.7%	0.0%	0.0%	4.1%	1.7%	0.0%	5.8%	0.0%	0.0%	1.4%	42.1%	0.0%	43.6%	0.0%	0.0%	
PHF	0.887	0.625	0.000	0.916	0.000	0.000	0.771	0.625	0.000	0.867	0.000	0.000	0.650	0.800	0.000	0.807	0.000	0.000	0.922
Lights	423	25	0	448	0	0	37	14	0	51	0	0	13	367	0	380	0	0	879
% Lights	97.7%	100.0%	0.0%	97.8%	0.0%	0.0%	100.0%	93.3%	0.0%	98.1%	0.0%	0.0%	100.0%	96.3%	0.0%	96.4%	0.0%	0.0%	97.2%
Trucks	0	0	0	0	0	0	0	0	0	0	0	0	0	0	0	0	0	0	0
% Trucks	0.0%	0.0%	0.0%	0.0%	0.0%	0.0%	0.0%	0.0%	0.0%	0.0%	0.0%	0.0%	0.0%	0.0%	0.0%	0.0%	0.0%	0.0%	0.0%
Buses	10	0	0	10	0	0	0	0	0	1	0	1	0	14	0	14	0	0	25
% Buses	2.3%	0.0%	0.0%	0.0%	0.0%	0.0%	0.0%	6.7%	0.0%	0.0%	0.0%	0.0%	0.0%	3.7%	0.0%	0.0%	0.0%	0.0%	2.8%
Pedestrians	0	0	0	0	1	4	0	0	0	0	9	10	0	0	0	0	2	3	0
% Pedestrians	0.0%	0.0%	0.0%	0.0%	100.0%	100.0%	0.0%	0.0%	0.0%	0.0%	100.0%	100.0%	0.0%	0.0%	0.0%	0.0%	100.0%	100.0%	0.0%
Bicycles on Crosswalk	0	0	0	0	0	0	0	0	0	0	0	0	0	0	0	0	0	0	0
% Bicycles on Crosswalk	0.0%	0.0%	0.0%	0.0%	0.0%	0.0%	0.0%	0.0%	0.0%	0.0%	0.0%	0.0%	0.0%	0.0%	0.0%	0.0%	0.0%	0.0%	0.0%

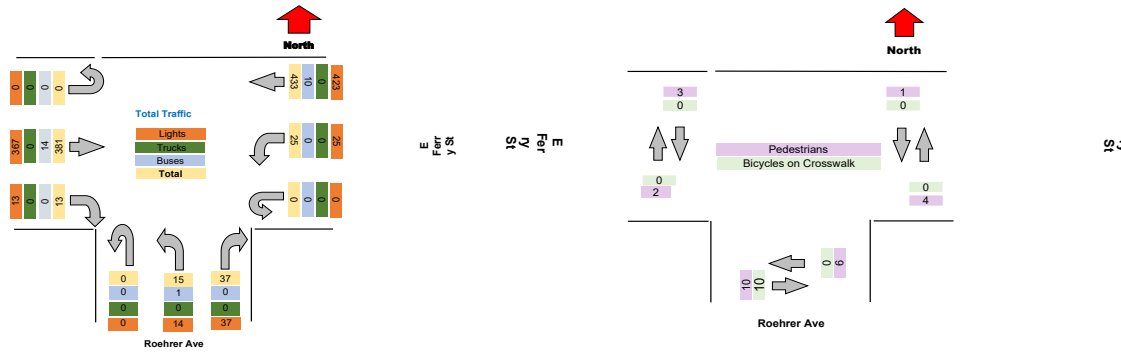

Project : VBH Malta NY
 Site : Site 4
 Location : 42.948550, -73.790036
 Survey Date : 2021-04-28, Wednesday

Turning Movement Data Plot

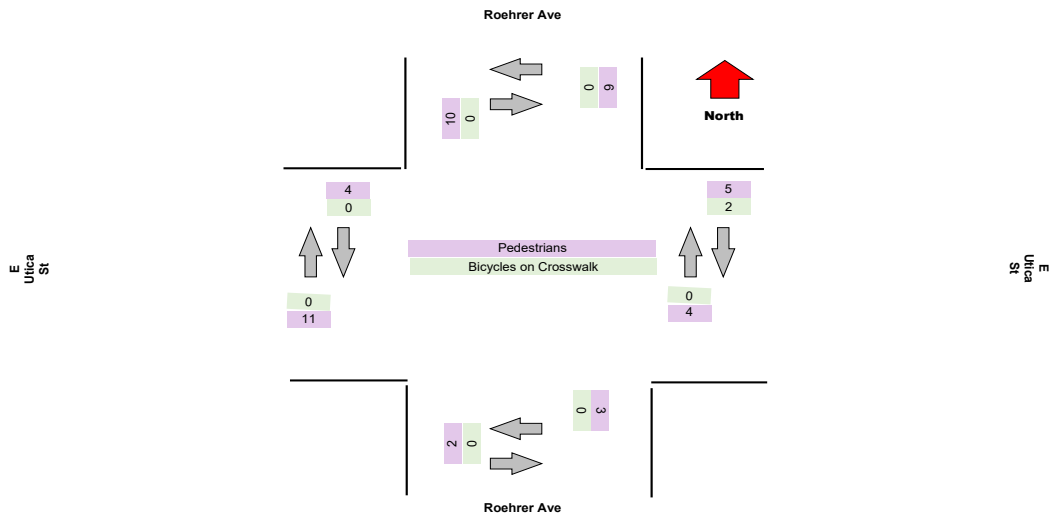
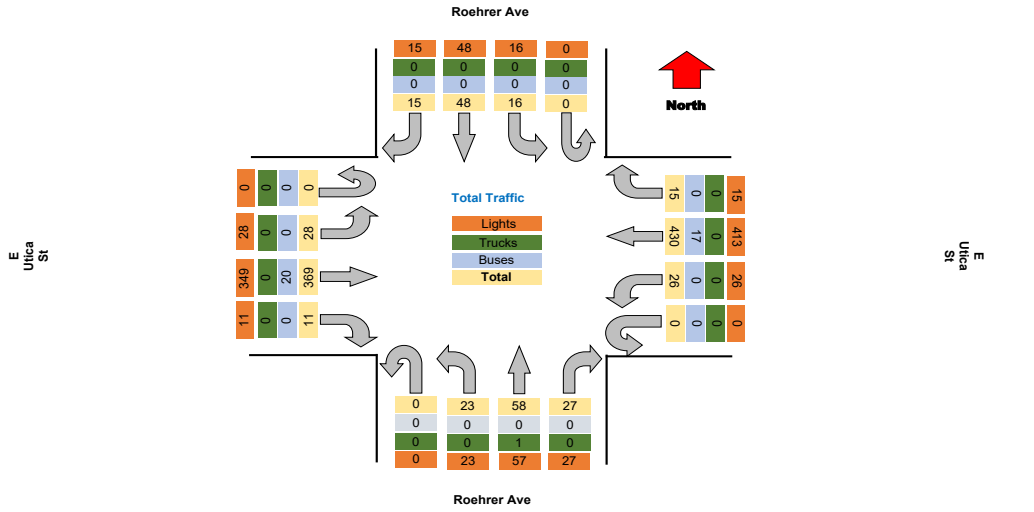

Project : VBH Malta NY
Site : Site 4
Location : 42.948550, -73.790036

TSTData.com

Survey Date : 2021-04-28, Wednesday

Turning Movement Peak Hour Data (AM)

7:30:00 AM

Leg Direction	Roehrer Ave								E Ulrica St								Roehrer Ave								E Ulrica St								Total
	Southbound				Westbound				Northbound				Eastbound				Northbound				Eastbound												
Start Time	Right	Thru	Left	U-Turn	App Total	Peds CW	Peds CCW		Right	Thru	Left	U-Turn	App Total	Peds CW	Peds CCW		Right	Thru	Left	U-Turn	App Total	Peds CW	Peds CCW		Right	Thru	Left	U-Turn	App Total	Peds CW	Peds CCW		
7:30:00 AM	0	0	0	0	0	0	0	0	0	13	0	0	13	1	0	0	1	1	1	0	4	0	0	0	1	11	1	0	13	0	0	0	30
7:45:00 AM	1	0	0	0	1	0	0	0	1	20	0	0	21	0	0	0	2	3	2	0	7	0	0	0	0	15	0	0	15	0	0	0	44
8:00:00 AM	1	0	1	0	2	0	0	0	0	28	0	0	28	0	0	0	0	1	1	0	2	0	0	0	0	21	0	0	21	0	0	0	53
8:15:00 AM	0	0	0	0	0	0	0	0	1	23	1	0	25	0	0	0	1	2	0	0	3	0	0	0	0	12	1	0	13	0	0	0	41
Grand Total	2	0	1	0	3	0	0	0	2	84	1	0	87	1	0	0	4	7	4	0	15	0	0	0	1	59	2	0	62	0	0	0	168
% Approach	66.7%	0.0%	33.3%	0.0%	0.0%	0.0%	0.0%	0.0%	2.3%	96.6%	1.1%	0.0%	0.0%	0.0%	0.0%	0.0%	25.0%	43.8%	25.0%	0.0%	0.0%	0.0%	0.0%	0.0%	1.6%	95.2%	3.2%	0.0%	0.0%	0.0%	0.0%	0.0%	
% Total	1.2%	0.0%	0.6%	0.0%	1.8%	0.0%	0.0%	0.0%	1.2%	50.0%	0.6%	0.0%	51.8%	0.0%	0.0%	0.0%	2.4%	4.2%	2.4%	0.0%	9.5%	0.0%	0.0%	0.0%	0.6%	35.1%	1.2%	0.0%	36.9%	0.0%	0.0%	0.0%	
PHF	0.500	0.000	0.250	0.000	0.375	0.000	0.000	0.000	0.500	0.750	0.250	0.000	0.777	0.000	0.000	0.000	0.500	0.583	0.500	0.000	0.571	0.000	0.000	0.000	0.250	0.702	0.500	0.000	0.738	0.000	0.000	0.000	0.792
Lights	2	0	1	0	3	0	0	0	2	80	1	0	83	0	0	0	4	7	4	0	15	0	0	0	1	54	2	0	57	0	0	0	158
% Lights	100.0%	0.0%	100.0%	0.0%	100.0%	0.0%	0.0%	0.0%	100.0%	95.2%	100.0%	0.0%	95.4%	0.0%	0.0%	0.0%	100.0%	100.0%	100.0%	0.0%	93.8%	0.0%	0.0%	0.0%	100.0%	91.5%	100.0%	0.0%	91.9%	0.0%	0.0%	0.0%	94.0%
Trucks	0	0	0	0	0	0	0	0	0	0	0	0	0	0	0	0	0	0	0	0	0	0	0	0	0	0	0	0	0	0	0	0	0
% Trucks	0.0%	0.0%	0.0%	0.0%	0.0%	0.0%	0.0%	0.0%	0.0%	0.0%	0.0%	0.0%	0.0%	0.0%	0.0%	0.0%	0.0%	0.0%	0.0%	0.0%	0.0%	0.0%	0.0%	0.0%	0.0%	0.0%	0.0%	0.0%	0.0%	0.0%	0.0%	0.0%	0.0%
Buses	0	0	0	0	0	0	0	0	0	4	0	0	4	0	0	0	0	0	0	0	0	0	0	0	0	5	0	0	5	0	0	0	9
% Buses	0.0%	0.0%	0.0%	0.0%	0.0%	0.0%	0.0%	0.0%	0.0%	4.8%	0.0%	0.0%	0.0%	0.0%	0.0%	0.0%	0.0%	0.0%	0.0%	0.0%	0.0%	0.0%	0.0%	0.0%	0.0%	8.5%	0.0%	0.0%	0.0%	0.0%	0.0%	0.0%	5.4%
Pedestrians	0	0	0	0	0	0	0	0	0	0	0	0	1	0	0	0	0	0	0	0	0	0	0	0	0	0	0	0	0	0	0	0	0
% Pedestrians	0.0%	0.0%	0.0%	0.0%	0.0%	0.0%	0.0%	0.0%	0.0%	0.0%	0.0%	0.0%	0.0%	100.0%	0.0%	0.0%	0.0%	0.0%	0.0%	0.0%	0.0%	0.0%	0.0%	0.0%	0.0%	0.0%	0.0%	0.0%	0.0%	0.0%	0.0%	0.0%	0.0%
Bicycles on Crosswalk	0	0	0	0	0	0	0	0	0	0	0	0	0	0	0	0	0	0	0	0	0	0	0	0	0	0	0	0	0	0	0	0	0
% Bicycles on Crosswalk	0.0%	0.0%	0.0%	0.0%	0.0%	0.0%	0.0%	0.0%	0.0%	0.0%	0.0%	0.0%	0.0%	0.0%	0.0%	0.0%	0.0%	0.0%	0.0%	0.0%	0.0%	0.0%	0.0%	0.0%	0.0%	0.0%	0.0%	0.0%	0.0%	0.0%	0.0%	0.0%	0.0%

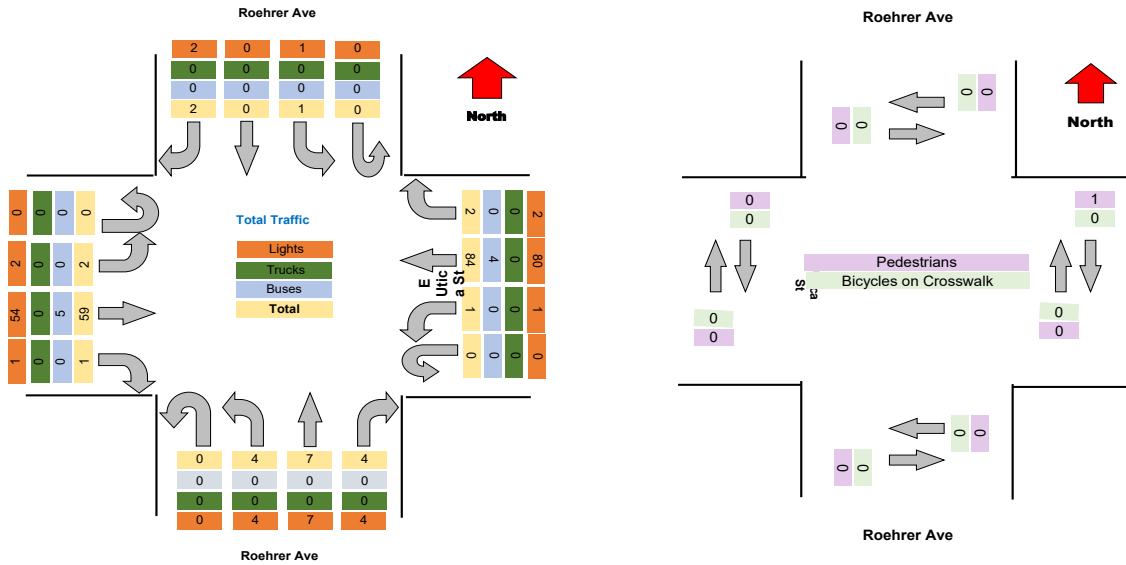

Turning Movement Peak Hour Data (PM)

4:15:00 PM

Leg Direction	Roehrer Ave												E Ulica St												Roehrer Ave												E Ulica St												Total
	Southbound						Westbound						Northbound						Eastbound																														
	Right	Thru	Left	U-Turn	App Total	Peds CW	Peds CCW	Right	Thru	Left	U-Turn	App Total	Peds CW	Peds CCW	Right	Thru	Left	U-Turn	App Total	Peds CW	Peds CCW	Right	Thru	Left	U-Turn	App Total	Peds CW	Peds CCW																					
4:15:00 PM	2	6	4	0	12	0	0	1	33	5	0	39	1	2	0	4	3	0	7	0	0	1	29	2	0	32	1	1	90																				
4:30:00 PM	2	6	2	0	10	2	2	2	38	1	0	41	1	1	2	4	1	0	7	1	0	0	41	0	0	41	1	0	99																				
4:45:00 PM	1	4	1	0	6	3	2	3	40	5	0	48	0	0	3	7	4	0	14	0	0	3	35	4	0	42	1	0	110																				
5:00:00 PM	2	5	2	0	9	3	1	1	41	7	0	49	0	0	3	9	2	0	14	0	0	0	35	5	0	40	1	1	112																				
Grand Total	7	21	9	0	37	8	5	7	152	18	0	177	2	3	8	24	10	0	42	1	0	4	140	11	0	155	4	2	411																				
% Approach	18.9%	56.8%	24.3%	0.0%	0.0%	0.0%	0.0%	4.0%	85.9%	10.2%	0.0%	0.0%	0.0%	0.0%	19.0%	57.1%	23.8%	0.0%	0.0%	0.0%	0.0%	2.6%	90.3%	7.1%	0.0%	0.0%	0.0%	0.0%																					
% Total	1.7%	5.1%	2.2%	0.0%	9.0%	0.0%	0.0%	1.7%	37.0%	4.4%	0.0%	43.1%	0.0%	0.0%	1.9%	5.8%	2.4%	0.0%	10.2%	0.0%	0.0%	1.0%	34.1%	2.7%	0.0%	37.7%	0.0%	0.0%																					
PHF	0.875	0.875	0.563	0.000	0.771	0.000	0.000	0.583	0.927	0.643	0.000	0.903	0.000	0.000	0.667	0.667	0.625	0.000	0.750	0.000	0.000	0.333	0.854	0.550	0.000	0.923	0.000	0.000	0.917																				
Lights	7	21	9	0	37	0	0	7	148	18	0	173	0	0	8	24	10	0	42	0	0	4	136	11	0	151	0	0	403																				
% Lights	100.0%	100.0%	100.0%	0.0%	100.0%	0.0%	0.0%	100.0%	97.4%	100.0%	0.0%	97.7%	0.0%	0.0%	100.0%	100.0%	100.0%	0.0%	100.0%	0.0%	0.0%	100.0%	97.1%	100.0%	0.0%	97.4%	0.0%	0.0%	98.1%																				
Trucks	0	0	0	0	0	0	0	0	0	0	0	0	0	0	0	0	0	0	0	0	0	0	0	0	0	0	0	0	0																				
% Trucks	0.0%	0.0%	0.0%	0.0%	0.0%	0.0%	0.0%	0.0%	0.0%	0.0%	0.0%	0.0%	0.0%	0.0%	0.0%	0.0%	0.0%	0.0%	0.0%	0.0%	0.0%	0.0%	0.0%	0.0%	0.0%	0.0%	0.0%	0.0%	0.0%																				
Buses	0	0	0	0	0	0	0	0	4	0	0	4	0	0	0	0	0	0	0	0	0	0	4	0	0	4	0	0	8																				
% Buses	0.0%	0.0%	0.0%	0.0%	0.0%	0.0%	0.0%	0.0%	2.6%	0.0%	0.0%	0.0%	0.0%	0.0%	0.0%	0.0%	0.0%	0.0%	0.0%	0.0%	0.0%	0.0%	2.9%	0.0%	0.0%	0.0%	0.0%	0.0%	1.9%																				
Pedestrians	0	0	0	0	8	5	0	0	0	0	0	1	3	0	0	0	0	0	1	0	0	0	0	0	0	0	4	2	0																				
% Pedestrians	0.0%	0.0%	0.0%	0.0%	0.0%	100.0%	100.0%	0.0%	0.0%	0.0%	0.0%	0.0%	50.0%	100.0%	0.0%	0.0%	0.0%	0.0%	0.0%	100.0%	0.0%	0.0%	0.0%	0.0%	0.0%	0.0%	100.0%	100.0%	0.0%																				
Bicycles on Crosswalk	0	0	0	0	0	0	0	0	0	0	0	1	0	0	0	0	0	0	0	0	0	0	0	0	0	0	0	0	0																				
% Bicycles on Crosswalk	0.0%	0.0%	0.0%	0.0%	0.0%	0.0%	0.0%	0.0%	0.0%	0.0%	0.0%	0.0%	50.0%	0.0%	0.0%	0.0%	0.0%	0.0%	0.0%	0.0%	0.0%	0.0%	0.0%	0.0%	0.0%	0.0%	0.0%	0.0%	0.0%																				

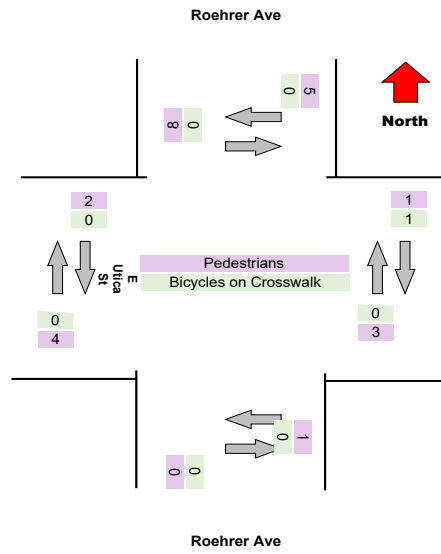
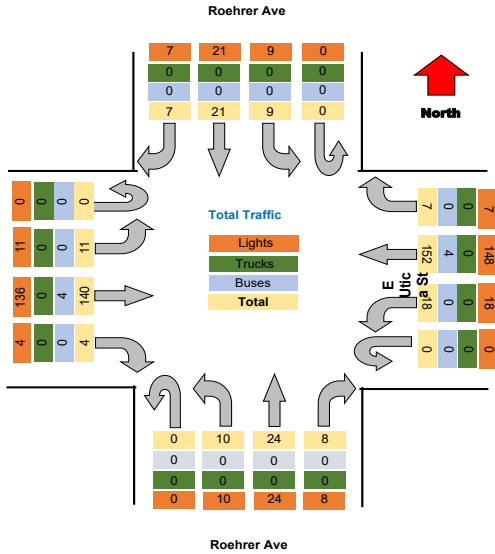

Project : VBH Malta NY
 Site : Site 4
 Location : 42.948550, -73.790036
 Survey Date : 2021-04-28, Wednesday

Turning Movement Data Plot

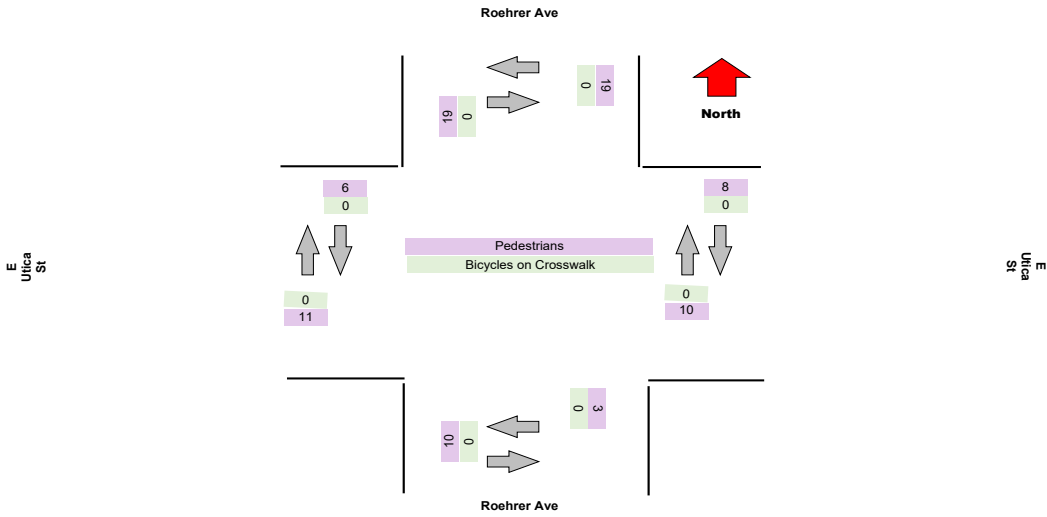
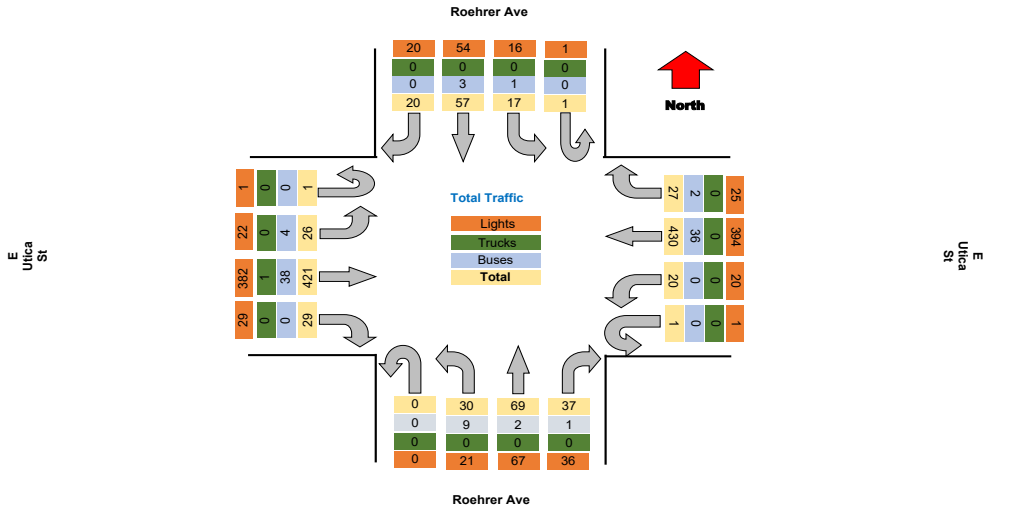

Project : VBH Malta NY
Site : Site 4
Location : 42.948550, -73.790036

TSTData.com

Survey Date : 2021-04-28, Wednesday

Turning Movement Peak Hour Data (AM)

7:30:00 AM

Leg Direction	Roehrer Ave Southbound					E Ulrica St Westbound					Roehrer Ave Northbound					E Ulrica St Eastbound					Total						
	Right	Thru	Left	U-Turn	App Total	Peds CW	Peds CCW	Right	Thru	Left	U-Turn	App Total	Peds CW	Peds CCW	Right	Thru	Left	U-Turn	App Total	Peds CW		Peds CCW					
7:30:00 AM	0	1	0	0	1	0	0	0	25	0	0	26	1	0	0	0	1	0	2	1	0	21	0	1	50		
7:45:00 AM	1	3	0	0	4	1	0	0	33	0	0	33	0	2	1	3	1	0	7	0	2	0	31	0	0	75	
8:00:00 AM	1	2	0	0	3	1	0	0	33	1	0	35	0	0	2	4	0	0	6	0	0	0	28	1	0	73	
8:15:00 AM	2	5	2	0	9	0	0	0	23	1	1	25	0	0	1	2	1	0	4	0	0	0	20	1	0	64	
Grand Total	4	11	2	0	17	2	0	0	114	2	1	124	1	2	4	9	3	0	19	1	2	0	88	4	0	282	
% Approach	23.5%	64.7%	11.8%	0.0%	0.0%	0.0%	0.0%	0.0%	4.8%	91.9%	1.6%	0.8%	0.0%	0.0%	0.0%	21.1%	47.4%	15.8%	0.0%	0.0%	0.0%	0.0%	96.1%	3.9%	0.0%	0.0%	
% Total	1.5%	4.2%	0.8%	0.0%	6.5%	0.0%	0.0%	0.0%	2.3%	43.5%	0.8%	0.4%	47.3%	0.0%	0.0%	1.5%	3.4%	1.1%	0.0%	7.3%	0.0%	0.0%	0.0%	37.4%	1.5%	0.0%	38.9%
PHF	0.500	0.550	0.250	0.000	0.472	0.000	0.000	0.000	0.300	0.884	0.500	0.250	0.886	0.000	0.000	0.500	0.563	0.750	0.000	0.679	0.000	0.000	0.000	0.790	0.500	0.000	0.823
Lights	4	11	2	0	17	0	0	0	6	103	2	1	112	0	0	0	9	0	0	13	0	0	0	84	1	0	85
% Lights	100.0%	100.0%	100.0%	0.0%	100.0%	0.0%	0.0%	0.0%	100.0%	90.4%	100.0%	100.0%	90.3%	0.0%	0.0%	0.0%	100.0%	100.0%	0.0%	68.4%	0.0%	0.0%	0.0%	85.7%	25.0%	0.0%	83.3%
Trucks	0	0	0	0	0	0	0	0	0	0	0	0	0	0	0	0	0	0	0	0	0	0	0	0	0	0	0
% Trucks	0.0%	0.0%	0.0%	0.0%	0.0%	0.0%	0.0%	0.0%	0.0%	0.0%	0.0%	0.0%	0.0%	0.0%	0.0%	0.0%	0.0%	0.0%	0.0%	0.0%	0.0%	0.0%	0.0%	0.0%	0.0%	0.0%	0.0%
Buses	0	0	0	0	0	0	0	0	11	0	0	11	0	0	0	0	3	0	0	3	0	0	0	14	3	0	17
% Buses	0.0%	0.0%	0.0%	0.0%	0.0%	0.0%	0.0%	0.0%	9.6%	0.0%	0.0%	8.9%	0.0%	0.0%	0.0%	0.0%	100.0%	0.0%	0.0%	0.0%	0.0%	0.0%	0.0%	14.3%	75.0%	0.0%	83.9%
Pedestrians	0	0	0	0	0	2	1	0	0	0	0	0	1	2	0	0	0	0	0	1	2	0	0	0	0	1	0
% Pedestrians	0.0%	0.0%	0.0%	0.0%	0.0%	100.0%	100.0%	0.0%	0.0%	0.0%	0.0%	0.0%	100.0%	100.0%	0.0%	0.0%	0.0%	0.0%	0.0%	0.0%	100.0%	100.0%	0.0%	0.0%	0.0%	100.0%	0.0%
Bicycles on Crosswalk	0	0	0	0	0	0	0	0	0	0	0	0	0	0	0	0	0	0	0	0	0	0	0	0	0	0	0
% Bicycles on Crosswalk	0.0%	0.0%	0.0%	0.0%	0.0%	0.0%	0.0%	0.0%	0.0%	0.0%	0.0%	0.0%	0.0%	0.0%	0.0%	0.0%	0.0%	0.0%	0.0%	0.0%	0.0%	0.0%	0.0%	0.0%	0.0%	0.0%	0.0%

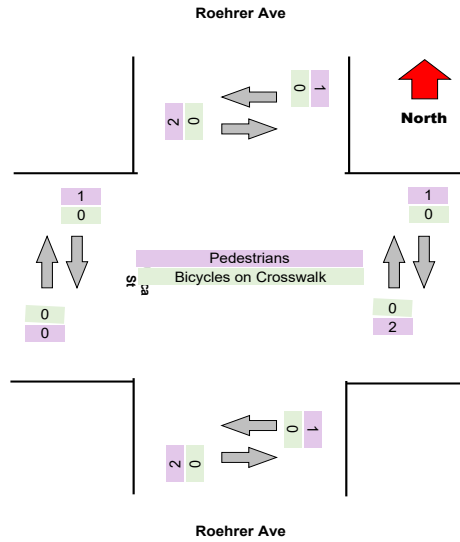
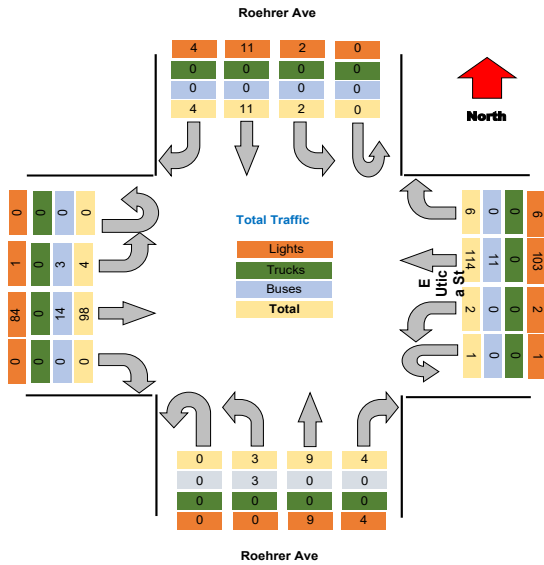

Turning Movement Peak Hour Data (PM)

4:15:00 PM

Leg Direction	Roehrer Ave				E Ulica St				Roehrer Ave				E Ulica St				Total												
	Southbound				Westbound				Northbound				Eastbound																
Start Time	Right	Thru	Left	U-Turn	App Total	Peds CW	Peds CCW	Right	Thru	Left	U-Turn	App Total	Peds CW	Peds CCW	Right	Thru	Left	U-Turn	App Total	Peds CW	Peds CCW								
4:15:00 PM	2	5	3	0	10	1	3	6	37	3	0	46	0	1	4	5	4	0	13	0	0	6	43	3	0	52	0	2	121
4:30:00 PM	2	5	1	0	8	3	0	2	34	3	0	39	0	1	6	5	4	0	15	0	1	1	33	2	0	36	0	1	98
4:45:00 PM	1	9	1	0	11	2	1	2	34	0	0	36	0	0	3	9	3	0	15	0	1	1	28	2	0	31	0	0	93
5:00:00 PM	2	7	4	0	13	2	4	4	32	0	0	36	0	0	2	4	3	0	9	0	1	0	38	3	1	42	0	1	100
Grand Total	7	28	9	0	42	6	8	14	137	6	0	157	0	2	15	23	14	0	52	0	2	8	142	10	1	161	3	4	412
% Approach	16.7%	61.0%	21.4%	0.0%	0.0%	0.0%	0.0%	8.9%	87.3%	3.8%	0.0%	0.0%	0.0%	0.0%	28.6%	44.2%	26.9%	0.0%	0.0%	0.0%	0.0%	5.0%	85.2%	6.2%	0.6%	0.0%	0.0%	0.0%	0.0%
% Total	1.7%	6.3%	2.2%	0.0%	10.2%	0.0%	0.0%	3.4%	33.3%	1.5%	0.0%	38.1%	0.0%	0.0%	3.6%	5.6%	3.4%	0.0%	12.6%	0.0%	0.0%	1.9%	34.5%	2.4%	0.2%	38.1%	0.0%	0.0%	0.0%
PHF	0.875	0.722	0.563	0.000	0.808	0.000	0.000	0.583	0.926	0.500	0.000	0.853	0.000	0.000	0.625	0.639	0.875	0.000	0.867	0.000	0.000	0.333	0.826	0.833	0.250	0.774	0.000	0.000	0.891
Lights	7	23	9	0	39	0	0	12	127	6	0	145	0	0	14	23	9	0	46	0	0	8	134	10	1	153	0	0	383
% Lights	100.0%	88.5%	100.0%	0.0%	92.9%	0.0%	0.0%	85.7%	92.7%	100.0%	0.0%	92.4%	0.0%	0.0%	83.3%	100.0%	64.3%	0.0%	88.5%	0.0%	0.0%	100.0%	94.4%	100.0%	100.0%	95.0%	0.0%	0.0%	93.0%
Trucks	0	0	0	0	0	0	0	0	0	0	0	0	0	0	0	0	0	0	0	0	0	0	1	0	0	1	0	0	1
% Trucks	0.0%	0.0%	0.0%	0.0%	0.0%	0.0%	0.0%	0.0%	0.0%	0.0%	0.0%	0.0%	0.0%	0.0%	0.0%	0.0%	0.0%	0.0%	0.0%	0.0%	0.0%	0.0%	0.7%	0.0%	0.0%	0.6%	0.0%	0.0%	0.2%
Buses	0	3	0	0	3	0	0	2	10	0	0	12	0	0	1	0	5	0	6	0	0	0	7	0	0	7	0	0	28
% Buses	0.0%	11.5%	0.0%	0.0%	0.0%	0.0%	0.0%	14.3%	7.3%	0.0%	0.0%	0.0%	0.0%	0.0%	6.7%	0.0%	35.7%	0.0%	0.0%	0.0%	0.0%	0.0%	4.9%	0.0%	0.0%	0.0%	0.0%	0.0%	6.8%
Pedestrians	0	0	0	0	0	8	6	0	0	0	0	0	2	0	0	0	0	0	0	3	0	0	0	0	0	0	0	4	0
% Pedestrians	0.0%	0.0%	0.0%	0.0%	0.0%	100.0%	100.0%	0.0%	0.0%	0.0%	0.0%	0.0%	100.0%	0.0%	0.0%	0.0%	0.0%	0.0%	0.0%	0.0%	100.0%	0.0%	0.0%	0.0%	0.0%	0.0%	0.0%	100.0%	0.0%
Bicycles on Crosswalk	0	0	0	0	0	0	0	0	0	0	0	0	0	0	0	0	0	0	0	0	0	0	0	0	0	0	0	0	0
% Bicycles on Crosswalk	0.0%	0.0%	0.0%	0.0%	0.0%	0.0%	0.0%	0.0%	0.0%	0.0%	0.0%	0.0%	0.0%	0.0%	0.0%	0.0%	0.0%	0.0%	0.0%	0.0%	0.0%	0.0%	0.0%	0.0%	0.0%	0.0%	0.0%	0.0%	0.0%

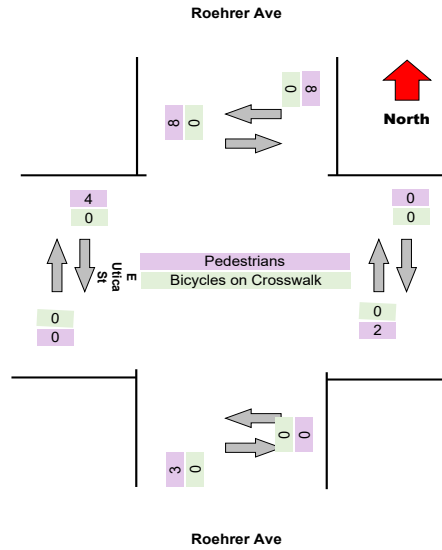
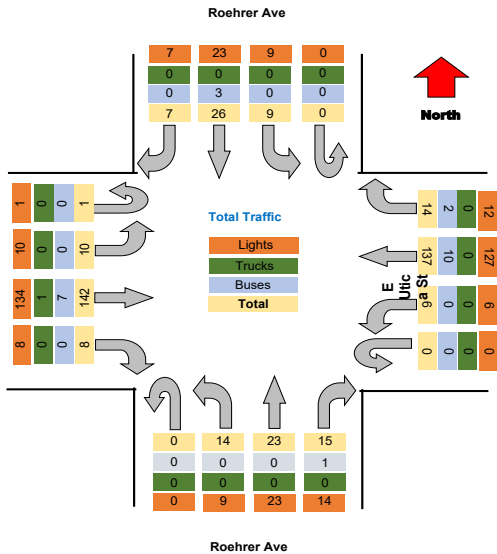

Project : VBH Malta NY
 Site : Site 4
 Location : 42.948550, -73.790036
 Survey Date : 2021-04-28, Wednesday

Turning Movement Data Plot

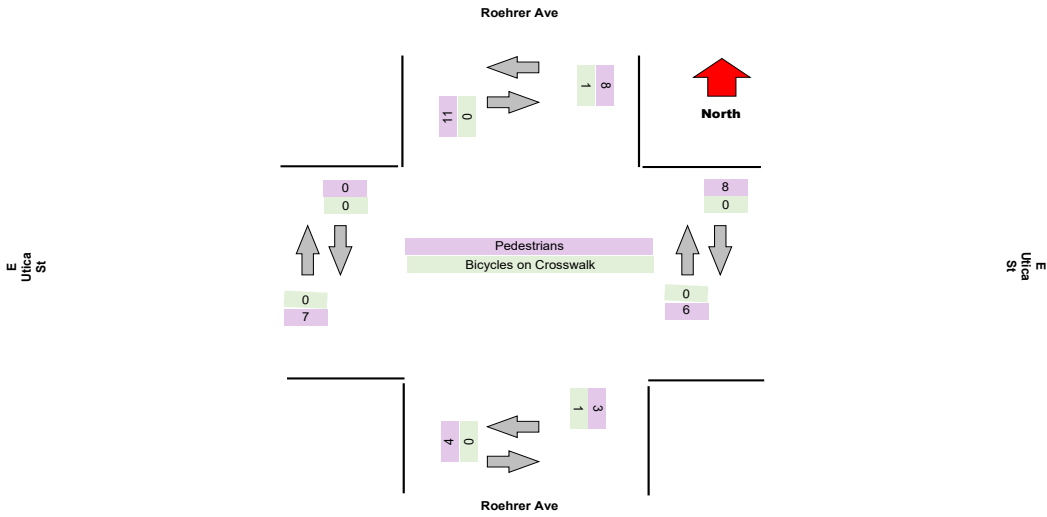
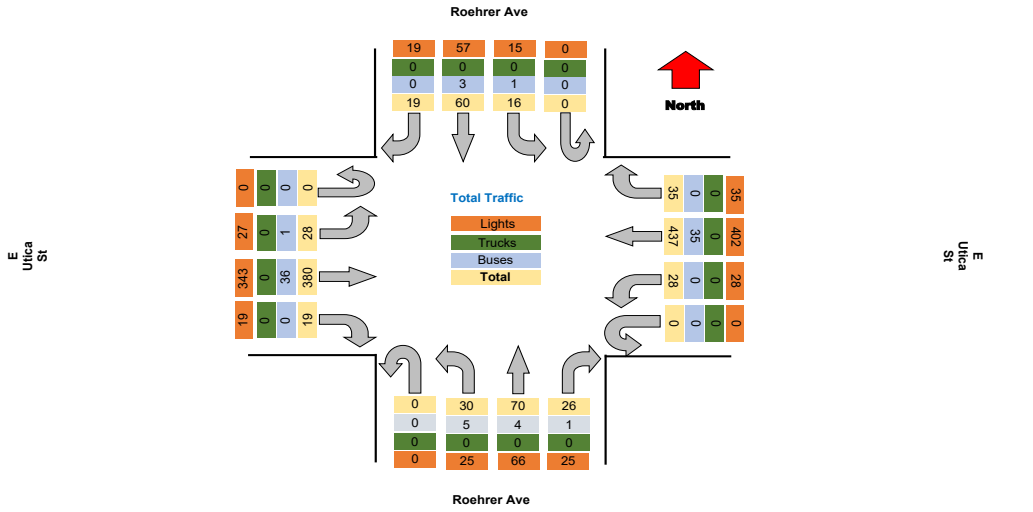

Turning Movement Peak Hour Data (AM)

7:30:00 AM

Leg Direction	Roehrer Ave							E Ulrica St							Roehrer Ave							E Ulrica St							Total	
	Southbound				App Total			Westbound				App Total			Northbound				App Total			Eastbound								
Start Time	Right	Thru	Left	U-Turn	Peds CW	Peds CCW	Right	Thru	Left	U-Turn	Peds CW	Peds CCW	Right	Thru	Left	U-Turn	Peds CW	Peds CCW	Right	Thru	Left	U-Turn	Peds CW	Peds CCW	Right	Thru	Left	U-Turn	Peds CW	Peds CCW
7:30:00 AM	0	1	0	0	1	0	0	0	29	1	0	30	0	0	3	1	1	0	5	0	0	0	18	1	0	19	0	0	55	
7:45:00 AM	1	2	0	0	3	0	0	1	35	1	0	37	0	0	2	2	1	0	5	0	1	1	21	1	0	23	2	0	68	
8:00:00 AM	0	3	0	0	3	0	0	3	29	3	0	35	0	0	0	3	0	0	3	0	0	0	26	1	0	27	0	0	68	
8:15:00 AM	0	2	0	0	2	0	0	3	22	0	0	25	0	0	0	2	0	0	2	0	0	1	14	1	0	16	0	0	46	
Grand Total	1	8	0	0	3	0	0	7	115	5	0	128	0	0	5	3	2	0	15	3	1	2	79	4	0	85	2	0	237	
% Approach	11.1%	88.9%	0.0%	0.0%	0.0%	0.0%	0.0%	5.5%	89.8%	3.9%	0.0%	0.0%	0.0%	0.0%	33.3%	53.3%	13.3%	0.0%	0.0%	0.0%	0.0%	2.4%	92.9%	4.7%	0.0%	0.0%	0.0%	0.0%	0.0%	
% Total	0.4%	3.4%	0.0%	0.0%	3.8%	0.0%	0.0%	3.0%	48.5%	2.1%	0.0%	54.0%	0.0%	0.0%	2.1%	3.4%	0.8%	0.0%	6.3%	0.0%	0.0%	0.8%	33.3%	1.7%	0.0%	35.9%	0.0%	0.0%	0.0%	
PHF	0.250	0.667	0.000	0.000	0.750	0.000	0.000	0.583	0.821	0.417	0.000	0.865	0.000	0.000	0.417	0.667	0.500	0.000	0.750	0.000	0.000	0.500	0.760	1.000	0.000	0.787	0.000	0.000	0.871	
Lights	1	7	0	0	8	0	0	7	104	5	0	116	0	0	5	7	1	0	13	0	0	2	64	4	0	70	0	0	207	
% Lights	100.0%	87.5%	0.0%	0.0%	88.9%	0.0%	0.0%	100.0%	90.4%	100.0%	0.0%	90.6%	0.0%	0.0%	100.0%	87.5%	50.0%	0.0%	86.7%	0.0%	0.0%	100.0%	61.0%	100.0%	0.0%	82.4%	0.0%	0.0%	87.3%	
Trucks	0	0	0	0	0	0	0	0	0	0	0	0	0	0	0	0	0	0	0	0	0	0	0	0	0	0	0	0	0	
% Trucks	0.0%	0.0%	0.0%	0.0%	0.0%	0.0%	0.0%	0.0%	0.0%	0.0%	0.0%	0.0%	0.0%	0.0%	0.0%	0.0%	0.0%	0.0%	0.0%	0.0%	0.0%	0.0%	0.0%	0.0%	0.0%	0.0%	0.0%	0.0%	0.0%	
Buses	0	1	0	0	1	0	0	0	11	0	0	11	0	0	0	1	1	0	2	0	0	0	15	0	0	15	0	0	29	
% Buses	0.0%	12.5%	0.0%	0.0%	0.0%	0.0%	0.0%	0.0%	9.6%	0.0%	0.0%	0.0%	0.0%	0.0%	0.0%	12.5%	50.0%	0.0%	0.0%	0.0%	0.0%	0.0%	19.0%	0.0%	0.0%	0.0%	0.0%	0.0%	12.2%	
Pedestrians	0	0	0	0	0	0	0	0	0	0	0	0	0	0	0	0	0	1	0	0	0	0	0	0	0	0	2	0	0	
% Pedestrians	0.0%	0.0%	0.0%	0.0%	0.0%	0.0%	100.0%	0.0%	0.0%	0.0%	0.0%	0.0%	0.0%	0.0%	0.0%	0.0%	0.0%	0.0%	0.0%	100.0%	0.0%	0.0%	0.0%	0.0%	0.0%	100.0%	0.0%	0.0%		
Bicycles on Crosswalk	0	0	0	0	0	0	0	0	0	0	0	0	0	0	0	0	0	0	0	0	0	0	0	0	0	0	0	0	0	
% Bicycles on Crosswalk	0.0%	0.0%	0.0%	0.0%	0.0%	0.0%	0.0%	0.0%	0.0%	0.0%	0.0%	0.0%	0.0%	0.0%	0.0%	0.0%	0.0%	0.0%	0.0%	0.0%	0.0%	0.0%	0.0%	0.0%	0.0%	0.0%	0.0%	0.0%	0.0%	

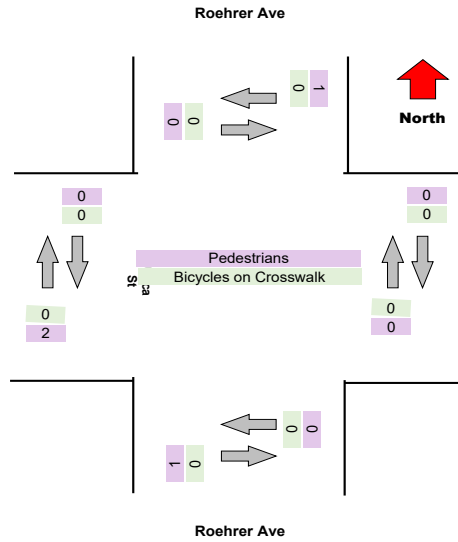
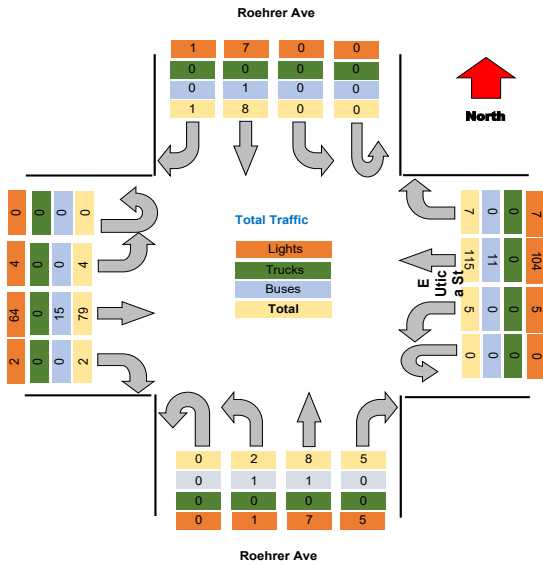

Turning Movement Peak Hour Data (PM)

4:15:00 PM

Leg Direction	Roehrer Ave										E Ulica St										Total									
	Southbound					Westbound					Northbound					Eastbound														
	Right	Thru	Left	U-Turn	App Total	Peds CW	Peds CCW	Right	Thru	Left	U-Turn	App Total	Peds CW	Peds CCW	Right	Thru	Left	U-Turn	App Total	Peds CW		Peds CCW								
4:15:00 PM	1	3	4	0	8	1	0	0	37	5	0	42	0	2	3	16	1	0	20	0	0	2	36	3	0	41	1	0	111	
4:30:00 PM	2	12	2	0	16	6	0	3	27	2	0	32	3	0	3	10	3	0	16	2	1	1	1	37	2	0	40	0	0	104
4:45:00 PM	3	6	1	0	10	2	2	3	42	0	0	45	1	0	2	7	5	0	14	0	0	0	2	43	2	0	47	0	0	116
5:00:00 PM	2	7	3	0	12	0	2	7	39	2	0	39	2	1	2	8	4	0	14	0	0	0	1	35	1	0	37	3	0	102
Grand Total	9	28	10	0	46	9	4	13	136	9	0	158	8	3	10	41	13	0	64	2	1	6	151	8	0	165	4	0	433	
% Approach	17.4%	60.0%	21.7%	0.0%	0.0%	0.0%	0.0%	8.2%	86.1%	5.7%	0.0%	0.0%	0.0%	0.0%	15.6%	64.1%	20.3%	0.0%	0.0%	0.0%	0.0%	0.0%	3.6%	91.5%	4.8%	0.0%	0.0%	0.0%	0.0%	0.0%
% Total	1.8%	6.5%	2.3%	0.0%	10.6%	0.0%	0.0%	3.0%	31.4%	2.1%	0.0%	36.5%	0.0%	0.0%	2.3%	9.5%	3.0%	0.0%	14.8%	0.0%	0.0%	0.0%	1.4%	34.9%	1.8%	0.0%	38.1%	0.0%	0.0%	0.0%
PHF	0.667	0.583	0.625	0.000	0.719	0.000	0.000	0.464	0.810	0.450	0.000	0.878	0.000	0.000	0.833	0.641	0.650	0.000	0.800	0.000	0.000	0.000	0.750	0.878	0.667	0.000	0.878	0.000	0.000	0.933
Lights	8	26	10	0	44	0	0	13	127	9	0	149	0	0	10	39	9	0	58	0	0	0	6	145	8	0	159	0	0	410
% Lights	100.0%	92.9%	100.0%	0.0%	95.7%	0.0%	0.0%	100.0%	93.4%	100.0%	0.0%	94.3%	0.0%	0.0%	100.0%	95.1%	69.2%	0.0%	90.6%	0.0%	0.0%	0.0%	100.0%	96.0%	100.0%	0.0%	96.4%	0.0%	0.0%	94.7%
Trucks	0	0	0	0	0	0	0	0	0	0	0	0	0	0	0	0	0	0	0	0	0	0	0	0	0	0	0	0	0	0
% Trucks	0.0%	0.0%	0.0%	0.0%	0.0%	0.0%	0.0%	0.0%	0.0%	0.0%	0.0%	0.0%	0.0%	0.0%	0.0%	0.0%	0.0%	0.0%	0.0%	0.0%	0.0%	0.0%	0.0%	0.0%	0.0%	0.0%	0.0%	0.0%	0.0%	0.0%
Buses	0	2	0	0	2	0	0	0	9	0	0	9	0	0	0	2	4	0	6	0	0	0	0	5	0	0	5	0	0	22
% Buses	0.0%	7.1%	0.0%	0.0%	0.0%	0.0%	0.0%	0.0%	6.6%	0.0%	0.0%	0.0%	0.0%	0.0%	0.0%	4.9%	30.8%	0.0%	0.0%	0.0%	0.0%	0.0%	0.0%	3.3%	0.0%	0.0%	0.0%	0.0%	0.0%	5.1%
Pedestrians	0	0	0	0	0	9	3	0	0	0	0	0	6	3	0	0	0	0	2	1	0	0	0	0	0	0	4	0	0	
% Pedestrians	0.0%	0.0%	0.0%	0.0%	0.0%	100.0%	75.0%	0.0%	0.0%	0.0%	0.0%	0.0%	100.0%	100.0%	0.0%	0.0%	0.0%	0.0%	0.0%	2	1	0	0	0	0	0	4	0	0	
Bicycles on Crosswalk	0	0	0	0	0	0	1	0	0	0	0	0	0	0	0	0	0	0	0	0	0	0	0	0	0	0	0	0	0	
% Bicycles on Crosswalk	0.0%	0.0%	0.0%	0.0%	0.0%	0.0%	25.0%	0.0%	0.0%	0.0%	0.0%	0.0%	0.0%	0.0%	0.0%	0.0%	0.0%	0.0%	0.0%	0.0%	0.0%	0.0%	0.0%	0.0%	0.0%	0.0%	0.0%	0.0%	0.0%	

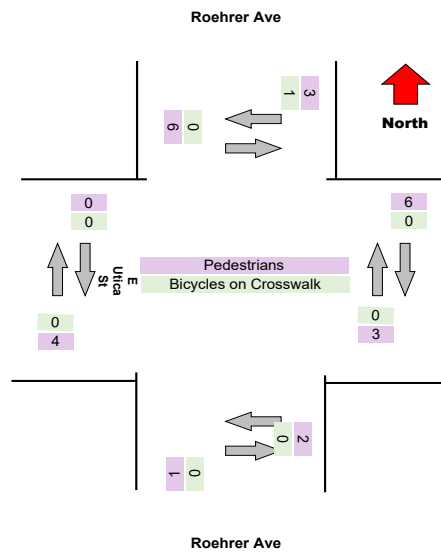
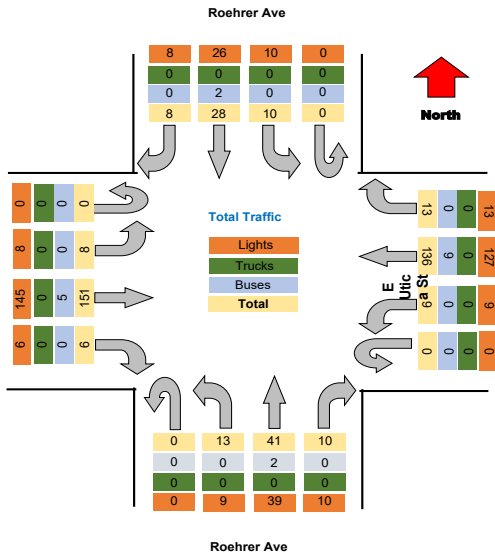

Project : VBH Malta NY
 Site : Site 4
 Location : 42.948550, -73.790036
 Survey Date : 2021-04-28, Wednesday

Turning Movement Data Plot

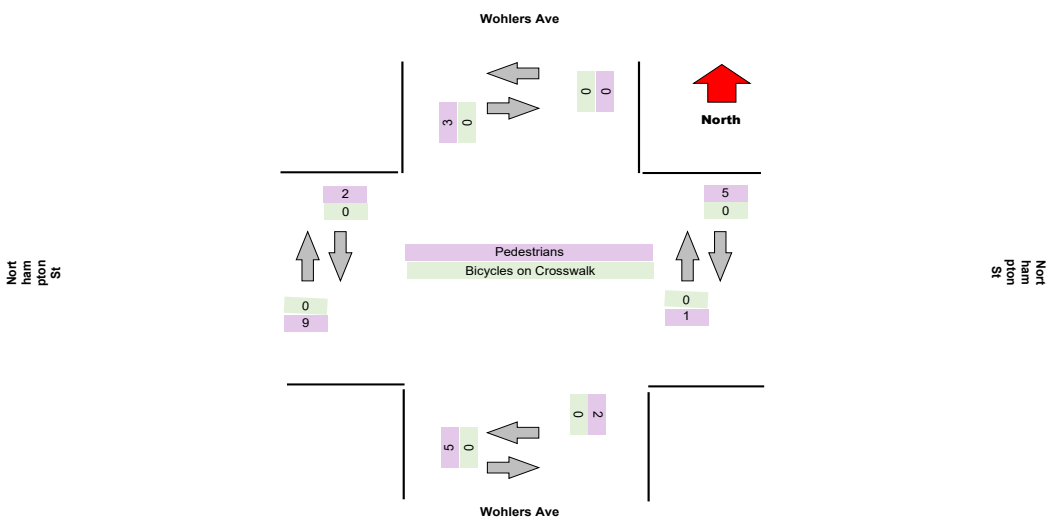
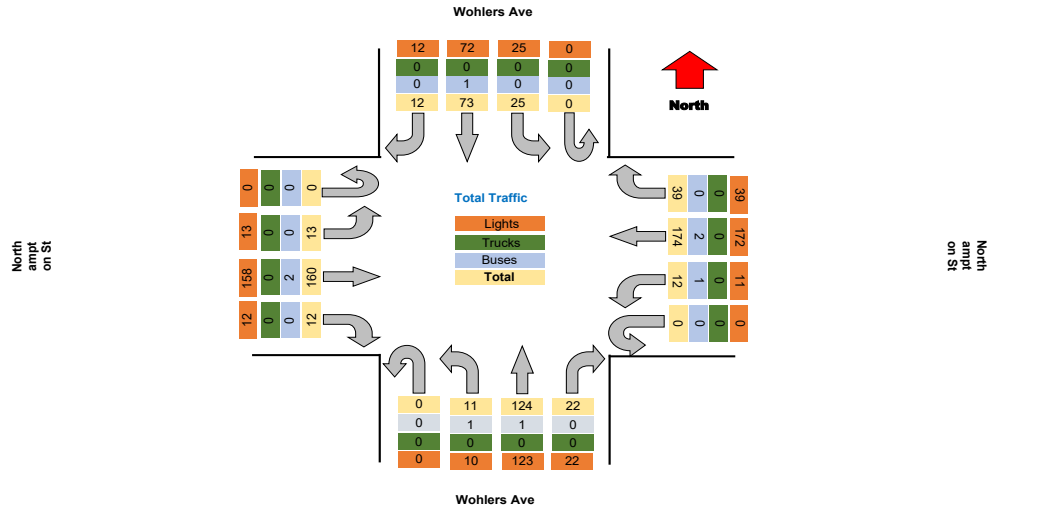

Project : VBH Malta NY
Site : Site 4
Location : 42.948550, -73.790036

TSTData.com

Survey Date : 2021-04-28, Wednesday

Turning Movement Peak Hour Data (AM)

7:30:00 AM

Leg Direction	Wohlers Ave						Northampton St						Wohlers Ave						Northampton St						Total					
	Southbound			Northbound			Westbound			Eastbound			Northbound			Eastbound														
Start Time	Right	Thru	Left	U-Turn	App Total	Peds CW	Peds CCW	Right	Thru	Left	U-Turn	App Total	Peds CW	Peds CCW	Right	Thru	Left	U-Turn	App Total	Peds CW	Peds CCW	Right	Thru	Left	U-Turn	App Total	Peds CW	Peds CCW		
7:30:00 AM	0	1	1	0	2	0	0	3	9	0	0	12	0	0	0	2	0	0	2	1	0	0	0	8	0	0	0	0	24	
7:45:00 AM	1	3	0	0	4	0	0	0	10	0	0	10	0	0	1	6	0	0	7	0	0	0	1	9	0	0	10	0	31	
8:00:00 AM	0	3	0	0	3	0	0	1	13	0	0	14	0	0	1	2	2	0	5	0	0	0	5	0	0	0	0	27		
8:15:00 AM	0	5	0	0	5	0	0	0	19	1	0	20	0	0	0	3	2	0	5	1	0	0	1	10	1	0	12	0	42	
Grand Total	1	12	1	0	14	0	0	4	51	1	0	56	0	0	2	13	4	0	19	2	0	0	2	32	1	0	35	0	124	
% Approach	7.1%	85.7%	7.1%	0.0%	0.0%	0.0%	0.0%	7.1%	91.1%	1.8%	0.0%	0.0%	0.0%	0.0%	10.5%	68.4%	21.1%	0.0%	0.0%	0.0%	0.0%	0.0%	5.7%	91.4%	2.9%	0.0%	0.0%	0.0%	0.0%	
% Total	0.8%	9.7%	0.8%	0.0%	11.3%	0.0%	0.0%	3.2%	41.1%	0.8%	0.0%	45.2%	0.0%	0.0%	1.6%	10.5%	3.2%	0.0%	15.3%	0.0%	0.0%	0.0%	1.6%	25.8%	0.8%	0.0%	28.2%	0.0%	0.0%	
PHF	0.250	0.600	0.250	0.000	0.700	0.000	0.000	0.333	0.671	0.250	0.000	0.700	0.000	0.000	0.500	0.542	0.500	0.000	0.679	0.000	0.000	0.000	0.500	0.800	0.250	0.000	0.729	0.000	0.000	0.738
Lights	1	12	1	0	14	0	0	4	51	1	0	56	0	0	2	13	4	0	19	0	0	0	2	31	1	0	34	0	123	
% Lights	100.0%	100.0%	100.0%	0.0%	100.0%	0.0%	0.0%	100.0%	100.0%	100.0%	0.0%	100.0%	0.0%	0.0%	100.0%	100.0%	100.0%	0.0%	100.0%	0.0%	0.0%	0.0%	100.0%	96.9%	100.0%	0.0%	97.1%	0.0%	0.0%	99.2%
Trucks	0	0	0	0	0	0	0	0	0	0	0	0	0	0	0	0	0	0	0	0	0	0	0	0	0	0	0	0	0	
% Trucks	0.0%	0.0%	0.0%	0.0%	0.0%	0.0%	0.0%	0.0%	0.0%	0.0%	0.0%	0.0%	0.0%	0.0%	0.0%	0.0%	0.0%	0.0%	0.0%	0.0%	0.0%	0.0%	0.0%	0.0%	0.0%	0.0%	0.0%	0.0%	0.0%	
Buses	0	0	0	0	0	0	0	0	0	0	0	0	0	0	0	0	0	0	0	0	0	0	1	0	0	0	1	0	1	
% Buses	0.0%	0.0%	0.0%	0.0%	0.0%	0.0%	0.0%	0.0%	0.0%	0.0%	0.0%	0.0%	0.0%	0.0%	0.0%	0.0%	0.0%	0.0%	0.0%	0.0%	0.0%	0.0%	3.1%	0.0%	0.0%	0.0%	0.0%	0.0%	0.8%	
Pedestrians	0	0	0	0	0	0	0	0	0	0	0	0	0	0	0	0	0	0	2	0	0	0	0	0	0	0	0	0	0	
% Pedestrians	0.0%	0.0%	0.0%	0.0%	0.0%	0.0%	0.0%	0.0%	0.0%	0.0%	0.0%	0.0%	0.0%	0.0%	0.0%	0.0%	0.0%	0.0%	0.0%	0.0%	0.0%	0.0%	0.0%	0.0%	0.0%	0.0%	0.0%	0.0%	0.0%	
Bicycles on Crosswalk	0	0	0	0	0	0	0	0	0	0	0	0	0	0	0	0	0	0	0	0	0	0	0	0	0	0	0	0	0	
% Bicycles on Crosswalk	0.0%	0.0%	0.0%	0.0%	0.0%	0.0%	0.0%	0.0%	0.0%	0.0%	0.0%	0.0%	0.0%	0.0%	0.0%	0.0%	0.0%	0.0%	0.0%	0.0%	0.0%	0.0%	0.0%	0.0%	0.0%	0.0%	0.0%	0.0%	0.0%	

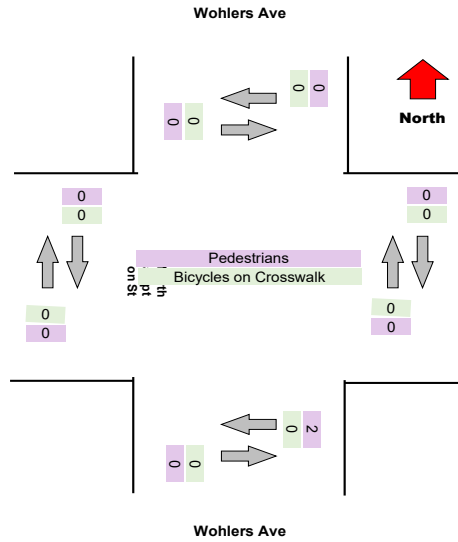
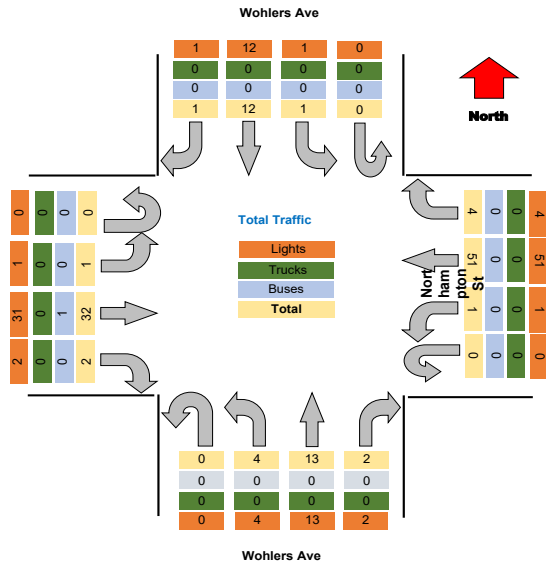

Turning Movement Peak Hour Data (PM)

4:15:00 PM

Leg Direction	Wohlers Ave										Northampton St										Wohlers Ave										Northampton St										Total
	Southbound					Westbound					Northbound					Eastbound					Northbound					Eastbound															
	Right	Thru	Left	U-Turn	App Total	Right	Thru	Left	U-Turn	App Total	Right	Thru	Left	U-Turn	App Total	Right	Thru	Left	U-Turn	App Total	Right	Thru	Left	U-Turn	App Total	Right	Thru	Left	U-Turn	App Total	Peds CW	Peds CCW									
4:15:00 PM	3	5	2	0	10	1	0	0	0	1	3	12	1	0	16	1	0	0	0	1	3	10	0	0	13	0	0	0	0	0	2	14	3	0	19	0	0				
4:30:00 PM	0	5	2	0	7	0	0	0	0	0	6	13	2	0	21	0	0	0	0	0	1	14	1	0	16	0	0	0	0	0	0	6	1	0	7	1	0				
4:45:00 PM	1	4	2	0	7	0	0	0	0	0	1	12	2	0	15	0	0	0	0	0	2	10	3	0	15	0	0	0	0	0	4	23	2	0	29	3	2				
5:00:00 PM	2	10	3	0	15	0	0	0	0	0	1	20	3	0	24	0	0	0	0	0	2	15	3	0	20	0	0	0	0	0	0	19	2	0	21	1	0				
Grand Total	6	24	9	0	39	0	0	0	0	0	11	57	6	0	75	0	0	0	0	0	8	49	7	0	64	0	0	0	0	0	6	62	8	0	76	5	2				
% Approach	15.4%	61.5%	23.1%	0.0%	0.0%	0.0%	0.0%	0.0%	0.0%	0.0%	14.5%	75.0%	10.5%	0.0%	0.0%	0.0%	0.0%	0.0%	0.0%	0.0%	12.5%	76.6%	10.9%	0.0%	0.0%	0.0%	0.0%	0.0%	0.0%	0.0%	7.9%	81.6%	10.5%	0.0%	0.0%	0.0%	0.0%				
% Total	2.4%	9.4%	3.5%	0.0%	15.3%	0.0%	0.0%	0.0%	0.0%	0.0%	4.3%	22.4%	3.1%	0.0%	29.8%	0.0%	0.0%	0.0%	0.0%	0.0%	3.1%	19.2%	2.7%	0.0%	25.1%	0.0%	0.0%	0.0%	0.0%	0.0%	2.4%	24.3%	3.1%	0.0%	29.8%	0.0%	0.0%				
PHF	0.500	0.600	0.750	0.000	0.650	0.000	0.000	0.000	0.000	0.000	0.458	0.713	0.667	0.000	0.792	0.000	0.000	0.000	0.000	0.000	0.667	0.817	0.583	0.000	0.800	0.000	0.000	0.000	0.000	0.000	0.375	0.674	0.667	0.000	0.655	0.000	0.000				
Lights	6	24	9	0	39	0	0	0	0	0	11	56	7	0	74	0	0	0	0	0	8	49	7	0	63	0	0	0	0	0	6	61	8	0	75	0	0				
% Lights	100.0%	100.0%	100.0%	0.0%	100.0%	0.0%	0.0%	0.0%	0.0%	0.0%	100.0%	98.2%	87.5%	0.0%	97.4%	0.0%	0.0%	0.0%	0.0%	0.0%	100.0%	100.0%	85.7%	0.0%	98.4%	0.0%	0.0%	0.0%	0.0%	0.0%	100.0%	98.4%	100.0%	0.0%	98.7%	0.0%	0.0%				
Trucks	0	0	0	0	0	0	0	0	0	0	0	0	0	0	0	0	0	0	0	0	0	0	0	0	0	0	0	0	0	0	0	0	0	0	0	0	0				
% Trucks	0.0%	0.0%	0.0%	0.0%	0.0%	0.0%	0.0%	0.0%	0.0%	0.0%	0.0%	0.0%	0.0%	0.0%	0.0%	0.0%	0.0%	0.0%	0.0%	0.0%	0.0%	0.0%	0.0%	0.0%	0.0%	0.0%	0.0%	0.0%	0.0%	0.0%	0.0%	0.0%									
Buses	0	0	0	0	0	0	0	0	0	0	1	1	0	0	2	0	0	0	0	0	0	0	0	0	0	1	0	0	0	1	0	0									
% Buses	0.0%	0.0%	0.0%	0.0%	0.0%	0.0%	0.0%	0.0%	0.0%	0.0%	0.0%	1.8%	12.5%	0.0%	0.0%	0.0%	0.0%	0.0%	0.0%	0.0%	0.0%	0.0%	14.3%	0.0%	0.0%	0.0%	1.8%	0.0%	0.0%	0.0%	0.0%	0.0%									
Pedestrians	0	0	0	0	0	2	0	0	0	2	0	0	0	0	0	0	0	0	0	0	0	0	0	0	0	4	0	0	0	4	0	0									
% Pedestrians	0.0%	0.0%	0.0%	0.0%	0.0%	100.0%	0.0%	0.0%	0.0%	0.0%	0.0%	0.0%	0.0%	0.0%	0.0%	0.0%	0.0%	0.0%	0.0%	0.0%	0.0%	0.0%	0.0%	0.0%	0.0%	0.0%	0.0%	0.0%	0.0%	0.0%	100.0%	100.0%									
Bicycles on Crosswalk	0	0	0	0	0	0	0	0	0	0	0	0	0	0	0	0	0	0	0	0	0	0	0	0	0	0	0	0	0	0	0	0									
% Bicycles on Crosswalk	0.0%	0.0%	0.0%	0.0%	0.0%	0.0%	0.0%	0.0%	0.0%	0.0%	0.0%	0.0%	0.0%	0.0%	0.0%	0.0%	0.0%	0.0%	0.0%	0.0%	0.0%	0.0%	0.0%	0.0%	0.0%	0.0%	0.0%	0.0%	0.0%	0.0%	0.0%	0.0%									

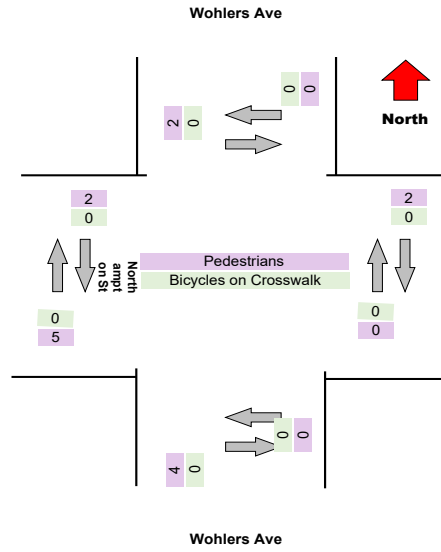
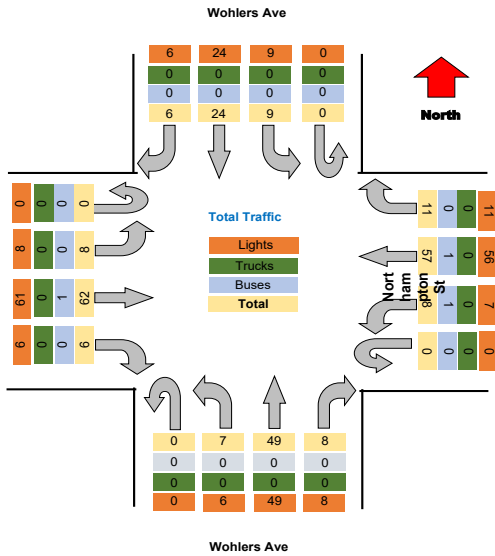

Project : VBH Malta NY
Site : Site 4
Location : 42.948550, -73.790036

TSTData.com

Survey Date : 2021-04-28, Wednesday

Project	LaBella
Project Code	LaBella
Site Name	R
Legs and Movements	All Processed Legs & Move
Bin Size	15 minutes
Survey Date	2021-11-03, Wednesday
Location	R
Latitude and Longitude	42.907400, -78.848086

	Start	End	PHF
Forced Peak AM	2021/11/03 07:30:00	2021/11/03 08:30:00	0.83
Forced Peak PM	2021/11/03 16:30:00	2021/11/03 17:30:00	0.88
AM Peak	2021/11/03 07:30:00	2021/11/03 08:30:00	0.83
PM Peak	2021/11/03 16:15:00	2021/11/03 17:15:00	0.96

Turning Movement Data

Leg Direction	Wohlers Ave										Northampton St										Wohlers Ave										Northampton St										Total
	Southbound					Westbound					Northbound					Eastbound					Southbound					Westbound					Northbound					Eastbound					
	Right	Thru	Left	U-Turn	App Total	Peds CV	Peds CCV	Right	Thru	Left	U-Turn	App Total	Peds CV	Peds CCV	Right	Thru	Left	U-Turn	App Total	Peds CV	Peds CCV	Right	Thru	Left	U-Turn	App Total	Peds CV	Peds CCV	Right	Thru	Left	U-Turn	App Total	Peds CV	Peds CCV						
6:30:00 AM	0	4	0	0	4	3	0	1	4	1	0	6	3	0	0	2	1	0	6	1	0	0	2	0	0	6	1	0	0	2	0	0	6	1	0	18					
6:45:00 AM	0	5	0	0	5	3	0	1	13	0	0	14	0	0	1	3	1	0	5	0	0	0	4	0	0	4	0	0	0	4	0	0	4	0	0	28					
Hourly Total	0	9	0	0	9	3	0	2	17	1	0	20	3	0	1	5	2	0	11	1	0	0	6	0	0	6	1	0	0	4	0	0	4	0	0	46					
7:00:00 AM	0	4	1	0	5	0	0	0	5	0	0	5	0	0	1	8	0	0	9	0	0	1	4	0	0	5	0	0	0	5	0	0	5	0	0	24					
7:15:00 AM	0	5	2	0	7	0	0	0	10	0	0	10	0	0	1	13	1	0	15	2	0	0	6	0	0	6	4	0	0	6	4	0	10	4	0	38					
7:30:00 AM	2	3	0	0	5	1	1	1	11	1	0	14	0	0	1	9	0	0	10	0	1	1	7	1	0	9	0	2	0	9	0	2	11	2	2	38					
7:45:00 AM	1	8	3	0	12	1	0	1	18	0	0	19	0	0	3	5	0	0	8	0	0	0	16	1	0	17	2	1	0	17	2	1	19	2	1	56					
Hourly Total	3	20	6	0	29	2	1	2	44	1	0	48	0	0	6	35	1	0	42	2	1	2	33	2	0	37	6	3	0	37	6	3	46	6	3	156					
8:00:00 AM	0	4	4	0	8	0	0	0	13	1	0	14	0	0	2	5	0	0	7	0	0	0	12	1	0	13	0	0	0	13	0	0	13	0	0	42					
8:15:00 AM	1	6	1	0	8	0	0	2	20	1	0	23	0	0	3	4	3	0	10	1	0	0	7	1	0	8	0	0	0	8	0	0	8	0	0	49					
Hourly Total	1	10	5	0	16	0	0	2	33	2	0	37	0	0	5	9	3	0	17	1	0	0	19	2	0	21	0	0	0	21	0	0	21	0	0	91					
4:00:00 PM	0	11	5	0	16	0	1	3	15	2	0	20	0	2	0	14	0	0	14	0	0	0	15	0	0	15	0	0	0	15	0	0	15	0	0	65					
4:15:00 PM	3	7	1	0	11	0	0	1	18	3	0	22	0	0	1	12	1	0	14	2	0	1	19	1	0	21	0	0	0	21	0	0	21	0	0	68					
4:30:00 PM	0	13	4	0	17	2	0	6	15	2	0	23	0	0	4	10	0	0	14	0	0	0	18	3	0	21	0	1	0	21	0	1	22	0	1	75					
4:45:00 PM	1	10	0	0	11	0	0	4	21	3	0	28	2	0	5	16	1	0	22	0	0	0	15	0	0	15	0	0	0	15	0	0	15	0	0	76					
Hourly Total	4	41	10	0	55	2	1	14	69	10	0	93	2	2	10	52	2	0	64	2	0	1	67	4	0	72	0	1	0	72	0	1	73	0	1	284					
5:00:00 PM	4	6	3	0	13	0	0	7	11	1	0	19	2	0	2	18	2	0	22	0	0	2	16	1	0	19	0	0	0	19	0	0	19	0	0	73					
5:15:00 PM	1	2	0	0	3	0	0	5	15	4	0	24	0	2	5	11	1	0	17	0	0	2	26	2	0	30	0	0	0	30	0	0	30	0	0	74					
5:30:00 PM	0	6	0	0	6	0	0	1	11	0	0	12	2	1	4	19	0	0	23	0	0	0	20	1	0	21	0	0	0	21	0	0	21	0	0	62					
5:45:00 PM	0	6	1	0	7	0	0	7	17	3	0	27	0	5	5	9	2	0	16	1	0	4	11	2	0	17	1	0	0	17	1	0	18	1	0	67					
Hourly Total	5	20	4	0	29	0	0	20	54	8	0	82	4	8	16	57	5	0	78	1	0	8	73	6	0	87	1	0	0	87	1	0	88	1	0	276					
Grand Total	13	100	25	0	138	7	2	40	217	22	0	280	9	10	38	158	13	0	212	7	1	11	198	14	0	223	6	4	0	223	6	4	229	6	4	853					
% Approach	9.4%	72.5%	18.1%	0.0%	0.0%	0.0%	0.0%	14.3%	77.5%	7.9%	0.0%	0.0%	0.0%	0.0%	17.9%	74.5%	6.1%	0.0%	0.0%	0.0%	0.0%	4.9%	88.8%	6.3%	0.0%	0.0%	0.0%	0.0%	0.0%	0.0%	0.0%	0.0%	0.0%	0.0%	0.0%	0.0%					
% Total	1.5%	11.7%	2.9%	0.0%	16.2%	0.0%	0.0%	4.7%	25.4%	2.6%	0.0%	32.8%	0.0%	0.0%	4.5%	18.5%	1.5%	0.0%	24.9%	0.0%	0.0%	1.3%	23.2%	1.6%	0.0%	26.1%	0.0%	0.0%	0.0%	0.0%	0.0%	0.0%	0.0%	0.0%	0.0%	0.0%					
Lights	10	94	21	0	125	0	0	38	213	20	0	271	0	0	37	153	12	0	202	0	0	11	167	12	0	210	0	0	0	210	0	0	210	0	0	808					
% Lights	76.3%	94.0%	84.9%	0.0%	90.6%	0.0%	0.0%	55.9%	98.2%	90.9%	0.0%	96.8%	0.0%	0.0%	97.4%	96.8%	92.3%	0.0%	95.3%	0.0%	0.0%	100.0%	94.4%	85.7%	0.0%	94.2%	0.0%	0.0%	0.0%	0.0%	0.0%	0.0%	0.0%	0.0%	0.0%	94.7%					
Trucks	0	0	0	0	0	0	0	0	0	0	0	0	0	0	0	0	0	0	0	0	0	0	0	0	0	0	0	0	0	0	0	0	0	0	0	0					
% Trucks	0.0%	0.0%	0.0%	0.0%	0.0%	0.0%	0.0%	0.0%	0.0%	0.0%	0.0%	0.0%	0.0%	0.0%	0.0%	0.0%	0.0%	0.0%	0.0%	0.0%	0.0%	0.0%	0.0%	0.0%	0.0%	0.0%	0.0%	0.0%	0.0%	0.0%	0.0%	0.0%	0.0%	0.0%	0.0%	0.0%					
Buses	3	6	4	0	13	0	0	2	4	2	0	8	0	0	1	5	1	0	7	0	0	0	11	2	0	13	0	0	0	13	0	0	13	0	0	41					
% Buses	23.1%	6.0%	16.0%	0.0%	0.0%	0.0%	0.0%	0.0%	1.8%	9.1%	0.0%	0.0%	0.0%	0.0%	2.6%	3.2%	7.7%	0.0%	0.0%	0.0%	0.0%	0.0%	5.6%	14.3%	0.0%	0.0%	0.0%	0.0%	0.0%	0.0%	0.0%	0.0%	0.0%	0.0%	0.0%	4.8%					
Pedestrians	0	0	0	0	0	7	2	0	0	0	0	0	9	10	0	0	0	0	0	7	1	0	0	0	0	0	8	4	0	0	8	4	0	8	4	0					
% Pedestrians	0.0%	0.0%	0.0%	0.0%	0.0%	100.0%	100.0%	0.0%	0.0%	0.0%	0.0%	0.0%	100.0%	100.0%	0.0%	0.0%	0.0%	0.0%	0.0%	100.0%	100.0%	0.0%	0.0%	0.0%	0.0%	0.0%	100.0%	100.0%	0.0%	0.0%	0.0%	0.0%	0.0%	0.0%	0.0%	0.0%					
Bicycles on Crosswalk	0	0	0	0	0	0	0	0	0	0	0	0	0	0	0	0	0	0	0	0	0	0	0	0	0	0	0	0	0	0	0	0	0	0	0	0					
% Bicycles on Crosswalk	0.0%	0.0%	0.0%	0.0%	0.0%	0.0%	0.0%	0.0%	0.0%	0.0%	0.0%	0.0%	0.0%	0.0%	0.0%	0.0%	0.0%	0.0%	0.0%	0.0%	0.0%	0.0%	0.0%	0.0%	0.0%	0.0%	0.0%	0.0%	0.0%	0.0%	0.0%	0.0%	0.0%	0.0%	0.0%	0.0%					

Project : VBH Malta NY
 Site : Site 4
 Location : 42.948550, -73.790036
 Survey Date : 2021-04-28, Wednesday

Turning Movement Data Plot

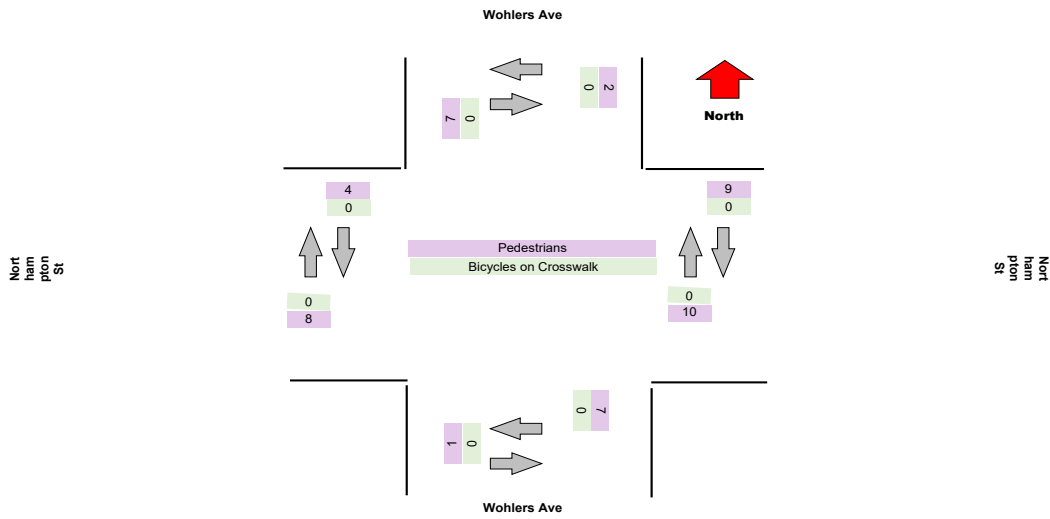
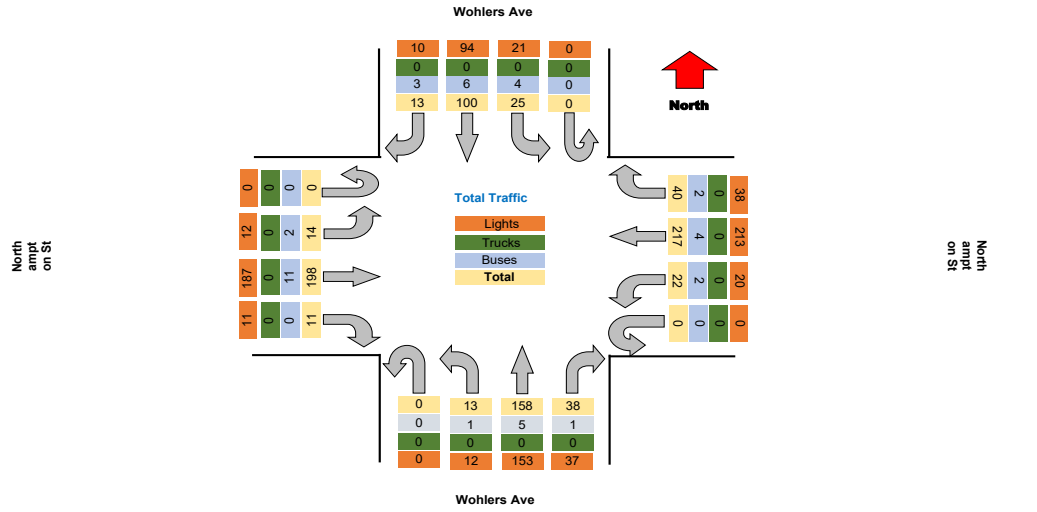

Turning Movement Peak Hour Data (AM)

7:30:00 AM

Leg Direction	Wohlers Ave						Northampton St						Wohlers Ave						Northampton St						Total			
	Southbound			Northbound			Westbound			Eastbound			Northbound			Eastbound												
Start Time	Right	Thru	Left	U-Turn	App Total	Peds CW	Peds CCW	Right	Thru	Left	U-Turn	App Total	Peds CW	Peds CCW	Right	Thru	Left	U-Turn	App Total	Peds CW	Peds CCW	Right	Thru	Left	U-Turn	App Total	Peds CW	Peds CCW
7:30:00 AM	2	3	0	0	5	1	1	1	11	1	0	14	0	0	1	9	0	0	10	0	1	1	7	1	0	9	0	2
7:45:00 AM	1	8	3	0	12	1	0	1	18	0	0	19	0	0	3	5	0	0	8	0	0	0	16	1	0	17	2	1
8:00:00 AM	0	4	4	0	8	0	0	0	13	1	0	14	0	0	2	5	0	0	7	0	0	0	12	1	0	13	0	0
8:15:00 AM	1	6	1	0	8	0	0	2	20	1	0	23	0	0	3	4	3	0	10	1	0	0	7	1	0	8	0	0
Grand Total	4	21	8	0	33	2	1	4	62	3	0	70	0	0	9	23	3	0	35	1	1	1	42	4	0	47	2	3
% Approach	12.1%	63.6%	24.2%	0.0%	0.0%	0.0%	0.0%	5.7%	88.6%	4.3%	0.0%	0.0%	0.0%	0.0%	25.7%	65.7%	8.6%	0.0%	0.0%	0.0%	0.0%	2.1%	89.4%	8.5%	0.0%	0.0%	0.0%	0.0%
% Total	2.2%	11.4%	4.3%	0.0%	17.8%	0.0%	0.0%	2.2%	33.5%	1.6%	0.0%	37.8%	0.0%	0.0%	4.9%	12.4%	1.6%	0.0%	18.9%	0.0%	0.0%	0.5%	22.7%	2.2%	0.0%	25.4%	0.0%	0.0%
PHF	0.500	0.656	0.500	0.000	0.688	0.000	0.000	0.500	0.775	0.750	0.000	0.761	0.000	0.000	0.750	0.639	0.250	0.000	0.875	0.000	0.000	0.250	0.656	1.000	0.000	0.691	0.000	0.000
Lights	2	20	6	0	28	0	0	4	62	2	0	68	0	0	9	21	3	0	33	0	0	1	38	2	0	41	0	0
% Lights	50.0%	95.2%	75.0%	0.0%	84.8%	0.0%	0.0%	100.0%	100.0%	66.7%	0.0%	97.1%	0.0%	0.0%	100.0%	91.3%	100.0%	0.0%	94.3%	0.0%	0.0%	100.0%	90.5%	50.0%	0.0%	87.2%	0.0%	0.0%
Trucks	0	0	0	0	0	0	0	0	0	0	0	0	0	0	0	0	0	0	0	0	0	0	0	0	0	0	0	0
% Trucks	0.0%	0.0%	0.0%	0.0%	0.0%	0.0%	0.0%	0.0%	0.0%	0.0%	0.0%	0.0%	0.0%	0.0%	0.0%	0.0%	0.0%	0.0%	0.0%	0.0%	0.0%	0.0%	0.0%	0.0%	0.0%	0.0%	0.0%	0.0%
Buses	2	1	2	0	5	0	0	0	0	1	0	1	0	0	0	2	0	0	2	0	0	0	4	2	0	6	0	0
% Buses	50.0%	4.8%	25.0%	0.0%	0.0%	0.0%	0.0%	0.0%	0.0%	33.3%	0.0%	0.0%	0.0%	0.0%	0.0%	8.7%	0.0%	0.0%	0.0%	0.0%	0.0%	0.0%	9.5%	50.0%	0.0%	0.0%	0.0%	0.0%
Pedestrians	0	0	0	0	0	2	1	0	0	0	0	0	0	0	0	1	1	0	0	0	0	0	0	0	0	0	2	3
% Pedestrians	0.0%	0.0%	0.0%	0.0%	0.0%	100.0%	100.0%	0.0%	0.0%	0.0%	0.0%	0.0%	0.0%	0.0%	0.0%	0.0%	0.0%	0.0%	0.0%	0.0%	0.0%	0.0%	0.0%	0.0%	0.0%	0.0%	100.0%	100.0%
Bicycles on Crosswalk	0	0	0	0	0	0	0	0	0	0	0	0	0	0	0	0	0	0	0	0	0	0	0	0	0	0	0	0
% Bicycles on Crosswalk	0.0%	0.0%	0.0%	0.0%	0.0%	0.0%	0.0%	0.0%	0.0%	0.0%	0.0%	0.0%	0.0%	0.0%	0.0%	0.0%	0.0%	0.0%	0.0%	0.0%	0.0%	0.0%	0.0%	0.0%	0.0%	0.0%	0.0%	0.0%

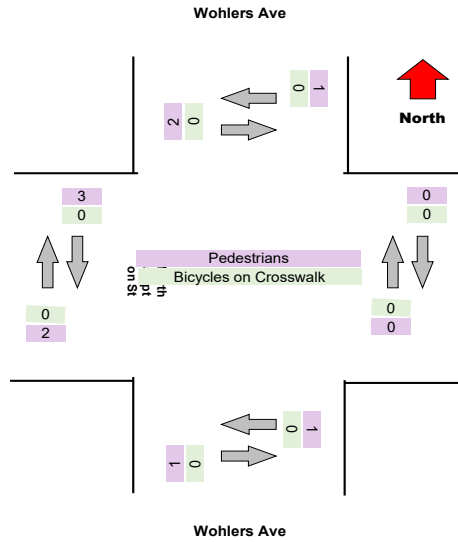
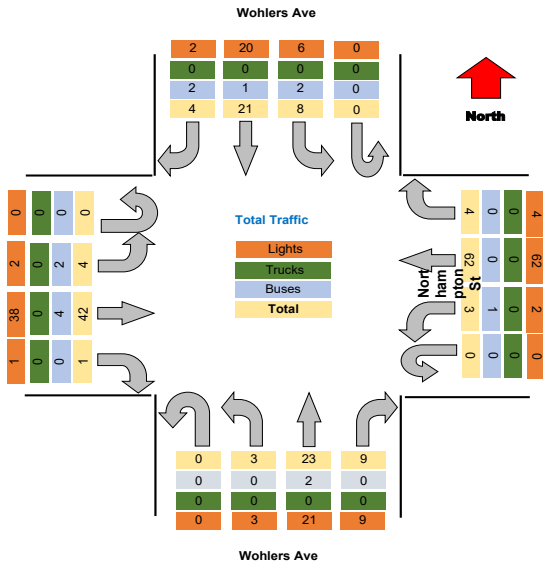

Turning Movement Peak Hour Data (PM)

4:15:00 PM

Leg Direction	Wohlers Ave										Northampton St										Total																									
	Southbound					Westbound					Northbound					Eastbound																														
	Right	Thru	Left	U-Turn	App Total	Right	Thru	Left	U-Turn	App Total	Right	Thru	Left	U-Turn	App Total	Right	Thru	Left	U-Turn	App Total																										
4:15:00 PM	3	7	1	0	11	0	0	0	0	0	1	18	3	0	22	0	0	0	0	0	1	12	1	0	14	2	0	0	0	2	1	19	1	0	21	0	0	0	0	0	68					
4:30:00 PM	0	13	4	0	17	2	0	0	0	2	6	15	2	0	23	0	0	0	0	0	4	10	0	0	14	0	0	0	0	0	0	18	3	0	21	0	1	0	0	1	75					
4:45:00 PM	1	10	0	0	11	0	0	0	0	0	4	21	3	0	28	2	0	0	0	2	5	16	1	0	22	0	0	0	0	0	0	15	0	0	15	0	0	0	0	0	76					
5:00:00 PM	4	5	3	0	12	0	0	0	0	0	7	11	1	0	19	2	0	0	0	2	2	18	2	0	22	0	0	0	0	0	2	16	1	0	19	0	0	0	0	0	73					
Grand Total	9	36	8	0	53	2	0	0	0	2	18	65	9	0	92	4	0	0	0	4	12	56	4	0	72	2	0	0	0	2	3	68	5	0	76	0	0	0	0	0	292					
% Approach	15.4%	69.2%	15.4%	0.0%	0.0%	0.0%	0.0%	0.0%	0.0%	0.0%	19.6%	70.7%	9.8%	0.0%	0.0%	0.0%	0.0%	0.0%	0.0%	0.0%	16.7%	77.8%	5.6%	0.0%	0.0%	0.0%	0.0%	0.0%	0.0%	0.0%	3.9%	89.5%	6.8%	0.0%	0.0%	0.0%	0.0%	0.0%	0.0%	0.0%						
% Total	2.7%	12.3%	2.7%	0.0%	17.8%	0.6%	22.3%	3.1%	0.0%	31.5%	0.6%	22.3%	3.1%	0.0%	31.5%	0.0%	0.0%	0.0%	0.0%	0.0%	4.1%	19.2%	1.4%	0.0%	24.7%	0.0%	0.0%	0.0%	0.0%	0.0%	1.0%	23.3%	1.7%	0.0%	26.0%	0.0%	0.0%	0.0%	0.0%	0.0%						
PHF	0.500	0.692	0.500	0.000	0.765	0.000	0.000	0.000	0.000	0.000	0.643	0.774	0.750	0.000	0.821	0.000	0.000	0.000	0.000	0.000	0.600	0.778	0.500	0.000	0.818	0.000	0.000	0.000	0.000	0.000	0.375	0.895	0.417	0.000	0.905	0.000	0.000	0.000	0.000	0.000						
Lights	7	34	7	0	48	0	0	0	0	0	16	63	8	0	87	0	0	0	0	0	11	56	4	0	71	0	0	0	0	0	3	64	5	0	72	0	0	0	0	0	278					
% Lights	87.5%	94.4%	87.5%	0.0%	92.3%	0.0%	0.0%	0.0%	0.0%	0.0%	88.9%	96.9%	88.9%	0.0%	94.6%	0.0%	0.0%	0.0%	0.0%	0.0%	81.7%	100.0%	100.0%	0.0%	98.6%	0.0%	0.0%	0.0%	0.0%	0.0%	100.0%	94.1%	100.0%	0.0%	94.7%	0.0%	0.0%	0.0%	0.0%	0.0%						
Trucks	0	0	0	0	0	0	0	0	0	0	0	0	0	0	0	0	0	0	0	0	0	0	0	0	0	0	0	0	0	0	0	0	0	0	0	0	0	0	0	0	0					
% Trucks	0.0%	0.0%	0.0%	0.0%	0.0%	0.0%	0.0%	0.0%	0.0%	0.0%	0.0%	0.0%	0.0%	0.0%	0.0%	0.0%	0.0%	0.0%	0.0%	0.0%	0.0%	0.0%	0.0%	0.0%	0.0%	0.0%	0.0%	0.0%	0.0%	0.0%	0.0%	0.0%	0.0%	0.0%	0.0%	0.0%	0.0%	0.0%	0.0%	0.0%						
Buses	1	2	1	0	4	2	2	1	0	5	2	2	1	0	5	1	0	0	0	1	1	0	0	0	1	0	4	0	0	4	0	0	0	0	0	4	0	0	0	4	0	0	0	0	0	14
% Buses	12.5%	5.6%	12.5%	0.0%	0.0%	11.1%	3.1%	11.1%	0.0%	0.0%	11.1%	3.1%	11.1%	0.0%	0.0%	8.3%	0.0%	0.0%	0.0%	0.0%	8.3%	0.0%	0.0%	0.0%	0.0%	0.0%	5.9%	0.0%	0.0%	0.0%	0.0%	4.0%	0.0%	0.0%	0.0%	0.0%	0.0%	0.0%	0.0%	0.0%						
Pedestrians	0	0	0	0	0	2	0	0	0	2	0	0	0	0	0	0	0	0	0	0	0	0	0	0	0	2	0	0	0	2	0	0	0	0	0	0	0	0	0	0	1	0	0	0	1	0
% Pedestrians	0.0%	0.0%	0.0%	0.0%	0.0%	100.0%	0.0%	0.0%	0.0%	0.0%	0.0%	0.0%	0.0%	0.0%	0.0%	0.0%	0.0%	0.0%	0.0%	0.0%	0.0%	0.0%	0.0%	0.0%	0.0%	100.0%	0.0%	0.0%	0.0%	0.0%	0.0%	0.0%	0.0%	0.0%	0.0%	0.0%	0.0%	0.0%	0.0%	0.0%						
Bicycles on Crosswalk	0	0	0	0	0	0	0	0	0	0	0	0	0	0	0	0	0	0	0	0	0	0	0	0	0	0	0	0	0	0	0	0	0	0	0	0	0	0	0	0	0	0	0	0	0	0
% Bicycles on Crosswalk	0.0%	0.0%	0.0%	0.0%	0.0%	0.0%	0.0%	0.0%	0.0%	0.0%	0.0%	0.0%	0.0%	0.0%	0.0%	0.0%	0.0%	0.0%	0.0%	0.0%	0.0%	0.0%	0.0%	0.0%	0.0%	0.0%	0.0%	0.0%	0.0%	0.0%	0.0%	0.0%	0.0%	0.0%	0.0%	0.0%	0.0%	0.0%	0.0%	0.0%						

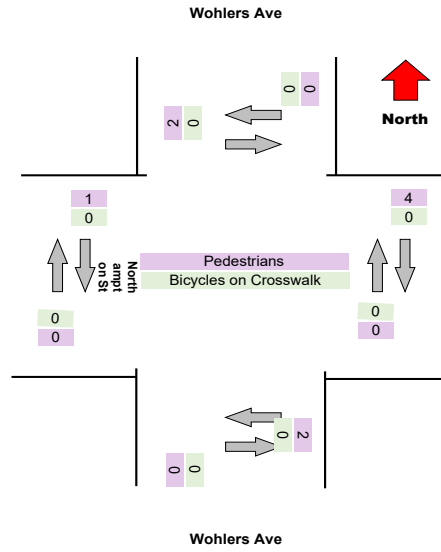
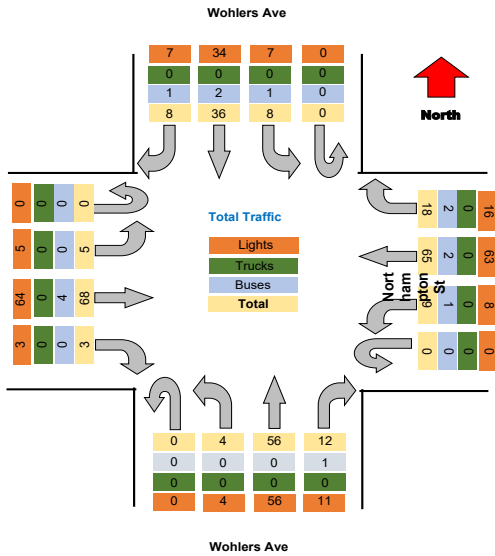

Project : VBH Malta NY
 Site : Site 4
 Location : 42.948550, -73.790036

TSTData.com

Survey Date : 2021-04-28, Wednesday

Project	LaBella
Project Code	LaBella
Site Name	R
Legs and Movements	All Processed Legs & Move
Bin Size	15 minutes
Survey Date	2021-11-04, Thursday
Location	R
Latitude and Longitude	42.907400, -78.848086

	Start	End	PHF
Forced Peak AM	2021/11/04 07:30:00	2021/11/04 08:30:00	0.83
Forced Peak PM	2021/11/04 16:30:00	2021/11/04 17:30:00	0.87
AM Peak	2021/11/04 07:30:00	2021/11/04 08:30:00	0.83
PM Peak	2021/11/04 16:15:00	2021/11/04 17:15:00	0.94

Turning Movement Data

Leg Direction	Wohlers Ave					Northampton St					Wohlers Ave					Northampton St					Total									
	Southbound					Westbound					Northbound					Eastbound														
	Right	Thru	Left	U-Turn	App Total	Peds CV	Peds CCV	Right	Thru	Left	U-Turn	App Total	Peds CV	Peds CCV	Right	Thru	Left	U-Turn	App Total	Peds CV		Peds CCV								
Start Time																														
6:30:00 AM	0	3	1	0	4	1	4	1	0	6	1	0	0	1	2	0	0	0	2	0	0	0	0	0	0	0	0	0	0	15
6:45:00 AM	0	1	1	0	2	0	4	0	0	4	0	0	0	0	0	5	0	0	5	0	0	0	0	0	0	0	0	0	0	12
Hourly Total	0	4	2	0	6	1	8	1	0	10	1	0	0	0	0	5	0	0	5	0	0	0	0	0	0	0	0	0	0	27
7:00:00 AM	0	4	1	0	5	3	9	1	0	13	0	0	0	0	0	7	0	0	7	0	0	0	0	0	0	3	0	0	3	28
7:15:00 AM	0	6	1	0	7	1	14	1	0	16	0	0	0	0	1	7	0	0	8	0	0	0	0	0	0	7	1	0	8	39
7:30:00 AM	1	4	0	0	5	1	11	2	0	15	1	0	0	0	1	6	1	0	8	0	1	0	0	1	1	8	1	0	10	39
7:45:00 AM	1	4	5	0	10	3	14	0	0	17	0	0	0	0	1	8	2	0	11	0	0	0	0	0	0	20	1	0	21	59
Hourly Total	2	18	7	0	27	8	48	4	0	61	1	0	0	0	3	28	3	0	35	0	1	0	0	1	1	38	3	0	42	165
8:00:00 AM	0	0	1	0	1	1	17	0	0	18	0	0	0	0	3	3	2	0	8	0	2	0	0	0	1	11	1	0	13	40
8:15:00 AM	3	3	4	0	10	2	19	0	0	21	0	0	0	0	0	8	3	0	11	0	0	0	0	0	1	13	3	0	17	59
Hourly Total	3	3	5	0	11	3	36	0	0	39	0	0	0	0	3	11	5	0	19	0	2	0	0	0	2	24	4	0	30	99
4:00:00 PM	0	16	3	0	19	6	15	0	0	21	0	0	0	0	2	16	2	0	20	0	0	0	0	0	1	30	2	0	33	93
4:15:00 PM	2	8	6	0	16	3	20	3	0	26	1	0	0	0	5	17	0	0	22	0	0	0	0	0	4	18	3	0	25	89
4:30:00 PM	0	10	5	0	15	6	18	0	0	24	1	1	0	0	2	19	2	0	23	0	1	0	0	0	3	22	1	0	26	88
4:45:00 PM	2	8	3	0	13	4	21	1	0	26	0	0	0	0	3	15	8	0	24	0	0	0	0	0	1	22	1	0	24	87
Hourly Total	4	42	17	0	63	19	74	4	0	97	2	1	0	0	12	67	10	0	89	0	1	0	0	0	9	92	7	0	108	357
5:00:00 PM	3	2	1	0	6	1	16	1	0	18	0	0	0	0	1	19	3	0	23	0	0	0	0	0	0	21	1	0	22	69
5:15:00 PM	1	5	3	0	9	5	18	0	0	23	0	0	0	0	2	8	2	0	12	0	0	0	0	0	1	17	0	0	18	62
5:30:00 PM	0	9	2	0	11	2	14	1	0	17	0	2	0	0	3	20	1	0	24	0	1	0	0	0	2	13	1	0	16	68
5:45:00 PM	0	6	4	0	10	5	18	2	0	25	1	0	0	0	3	11	1	0	15	0	0	0	0	0	3	11	2	0	16	66
Hourly Total	4	22	10	0	36	13	66	4	0	83	1	3	0	0	9	58	7	0	74	0	1	0	0	0	6	62	4	0	72	265
Grand Total	13	89	41	0	143	44	232	13	0	290	5	4	0	0	27	170	25	0	224	0	5	0	0	0	18	220	18	0	256	913
% Approach	9.1%	62.2%	28.7%	0.0%	0.0%	15.2%	80.0%	4.5%	0.0%	0.0%	12.1%	75.9%	11.2%	0.0%	0.0%	7.0%	85.9%	7.0%	0.0%	0.0%	0.0%	0.0%	0.0%	0.0%	0.0%	0.0%	0.0%	0.0%	0.0%	0.0%
% Total	1.4%	8.7%	4.5%	0.0%	15.7%	4.8%	25.4%	1.4%	0.0%	31.8%	3.0%	18.6%	2.7%	0.0%	24.5%	2.0%	24.1%	2.0%	0.0%	28.0%	0.0%	0.0%	0.0%	0.0%	0.0%	0.0%	0.0%	0.0%	0.0%	0.0%
Lights	8	84	37	0	129	42	230	12	0	284	0	0	0	0	25	166	24	0	215	0	0	0	0	0	17	211	16	0	244	872
% Lights	61.5%	94.4%	90.2%	0.0%	90.2%	95.5%	99.1%	92.3%	0.0%	97.9%	0.0%	0.0%	0.0%	0.0%	92.6%	97.6%	96.0%	0.0%	96.0%	0.0%	0.0%	0.0%	0.0%	0.0%	94.4%	95.9%	88.9%	0.0%	95.3%	95.9%
Trucks	0	0	0	0	0	0	0	0	0	0	0	0	0	0	0	0	0	0	0	0	0	0	0	0	0	0	0	0	0	0
% Trucks	0.0%	0.0%	0.0%	0.0%	0.0%	0.0%	0.0%	0.0%	0.0%	0.0%	0.0%	0.0%	0.0%	0.0%	0.0%	0.0%	0.0%	0.0%	0.0%	0.0%	0.0%	0.0%	0.0%	0.0%	0.0%	0.0%	0.0%	0.0%	0.0%	
Buses	5	5	4	0	14	2	2	1	0	5	0	0	0	0	2	4	1	0	7	0	0	0	0	0	1	9	2	0	12	38
% Buses	38.5%	5.6%	9.8%	0.0%	0.0%	0.0%	0.9%	7.7%	0.0%	0.0%	0.0%	0.0%	0.0%	0.0%	7.4%	2.4%	4.0%	0.0%	0.0%	0.0%	0.0%	0.0%	0.0%	0.0%	5.6%	4.1%	11.1%	0.0%	0.0%	4.2%
Pedestrians	0	0	0	0	0	0	0	0	0	0	5	4	0	0	0	0	0	0	0	0	0	0	0	0	0	0	0	0	0	7
% Pedestrians	0.0%	0.0%	0.0%	0.0%	0.0%	0.0%	0.0%	0.0%	0.0%	0.0%	100.0%	100.0%	0.0%	0.0%	0.0%	0.0%	0.0%	0.0%	0.0%	0.0%	0.0%	0.0%	0.0%	0.0%	0.0%	0.0%	0.0%	0.0%	0.0%	
Bicycles on Crosswalk	0	0	0	0	0	0	0	0	0	0	0	0	0	0	0	0	0	0	0	0	0	0	0	0	0	0	0	0	0	0
% Bicycles on Crosswalk	0.0%	0.0%	0.0%	0.0%	0.0%	0.0%	0.0%	0.0%	0.0%	0.0%	0.0%	0.0%	0.0%	0.0%	0.0%	0.0%	0.0%	0.0%	0.0%	0.0%	0.0%	0.0%	0.0%	0.0%	0.0%	0.0%	0.0%	0.0%	0.0%	

Project : VBH Malta NY
 Site : Site 4
 Location : 42.948550, -73.790036
 Survey Date : 2021-04-28, Wednesday

Turning Movement Data Plot

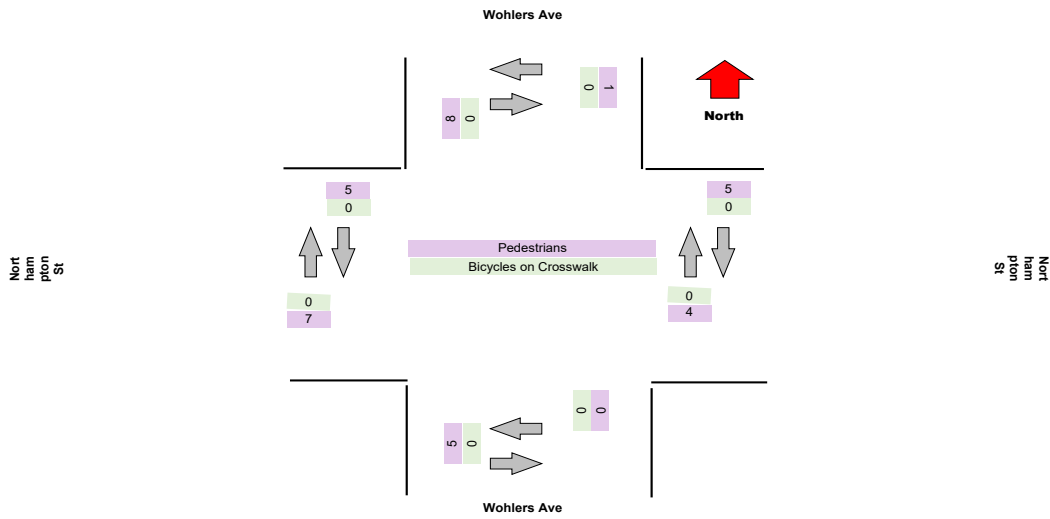
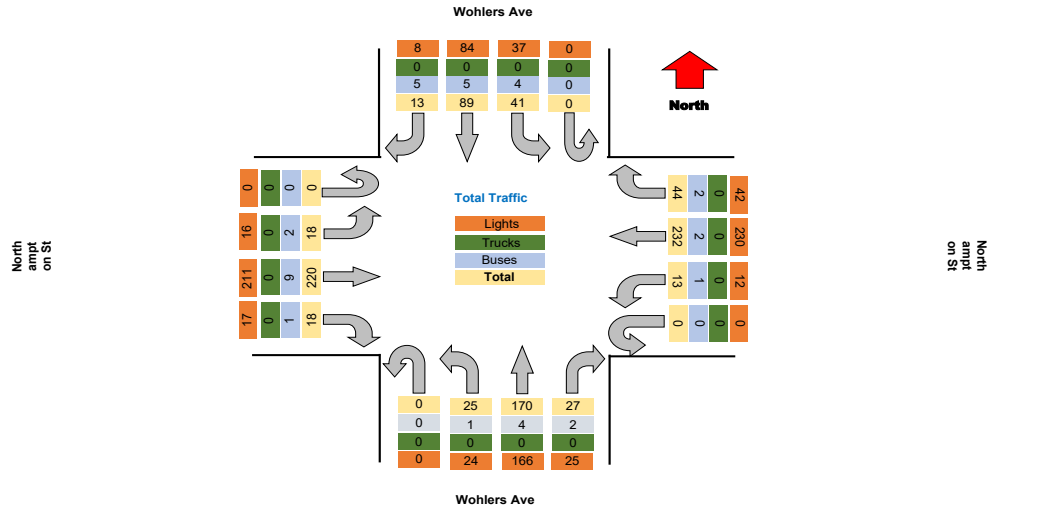

Project : VBH Malta NY
Site : Site 4
Location : 42.948550, -73.790036
Survey Date : 2021-04-28, Wednesday

TSTData.com

Turning Movement Peak Hour Data (AM)

7:30:00 AM

Leg Direction	Wohlers Ave					Northampton St					Wohlers Ave					Northampton St					Total								
	Southbound					Westbound					Northbound					Eastbound													
Start Time	Right	Thru	Left	U-Turn	App Total	Peds CW	Peds CCW	Right	Thru	Left	U-Turn	App Total	Peds CW	Peds CCW	Right	Thru	Left	U-Turn	App Total	Peds CW	Peds CCW	Right	Thru	Left	U-Turn	App Total	Peds CW	Peds CCW	
7:30:00 AM	1	4	0	0	5	1	1	1	11	2	0	15	1	0	1	6	1	0	9	0	1	1	8	1	0	10	2	1	39
7:45:00 AM	1	4	5	0	10	0	0	3	14	0	0	17	0	0	1	8	2	0	11	0	0	0	20	1	0	21	0	0	59
8:00:00 AM	0	0	1	0	1	0	0	1	17	0	0	18	0	0	3	3	2	0	8	0	2	1	11	1	0	13	0	1	40
8:15:00 AM	3	3	4	0	10	0	0	2	19	0	0	21	0	0	0	3	3	0	11	0	0	1	13	3	0	17	0	0	59
Grand Total	5	11	10	0	25	1	1	7	61	2	0	71	1	0	5	25	8	0	39	0	3	3	52	8	0	61	2	2	197
% Approach	19.2%	42.3%	38.5%	0.0%	0.0%	0.0%	0.0%	9.9%	85.9%	2.8%	0.0%	0.0%	0.0%	0.0%	12.8%	64.1%	20.5%	0.0%	0.0%	0.0%	0.0%	4.9%	85.2%	9.8%	0.0%	0.0%	0.0%	0.0%	0.0%
% Total	2.5%	5.6%	5.1%	0.0%	13.2%	0.0%	0.0%	3.6%	31.0%	1.0%	0.0%	36.0%	0.0%	0.0%	2.5%	12.7%	4.1%	0.0%	19.8%	0.0%	0.0%	1.5%	26.4%	3.0%	0.0%	31.0%	0.0%	0.0%	0.0%
PHF	0.417	0.688	0.500	0.000	0.650	0.000	0.000	0.583	0.803	0.250	0.000	0.845	0.000	0.000	0.417	0.781	0.667	0.000	0.886	0.000	0.000	0.750	0.650	0.500	0.000	0.726	0.000	0.000	0.835
Lights	3	10	8	0	21	0	0	6	61	2	0	69	0	0	5	23	7	0	35	0	0	3	48	4	0	55	0	0	180
% Lights	60.0%	90.9%	80.0%	0.0%	80.8%	0.0%	0.0%	85.7%	100.0%	100.0%	0.0%	97.2%	0.0%	0.0%	100.0%	92.0%	87.5%	0.0%	89.7%	0.0%	0.0%	100.0%	92.3%	66.7%	0.0%	90.2%	0.0%	0.0%	91.4%
Trucks	0	0	0	0	0	0	0	0	0	0	0	0	0	0	0	0	0	0	0	0	0	0	0	0	0	0	0	0	0
% Trucks	0.0%	0.0%	0.0%	0.0%	0.0%	0.0%	0.0%	0.0%	0.0%	0.0%	0.0%	0.0%	0.0%	0.0%	0.0%	0.0%	0.0%	0.0%	0.0%	0.0%	0.0%	0.0%	0.0%	0.0%	0.0%	0.0%	0.0%	0.0%	0.0%
Buses	2	1	2	0	5	0	0	1	0	0	0	1	0	0	0	2	1	0	3	0	0	0	4	2	0	6	0	0	15
% Buses	40.0%	9.1%	20.0%	0.0%	0.0%	0.0%	0.0%	14.3%	0.0%	0.0%	0.0%	0.0%	0.0%	0.0%	0.0%	8.0%	12.5%	0.0%	0.0%	0.0%	0.0%	0.0%	7.7%	33.3%	0.0%	0.0%	0.0%	0.0%	7.6%
Pedestrians	0	0	0	0	0	1	1	0	0	0	0	0	1	0	0	0	0	0	0	0	3	0	0	0	0	0	2	2	0
% Pedestrians	0.0%	0.0%	0.0%	0.0%	0.0%	100.0%	100.0%	0.0%	0.0%	0.0%	0.0%	0.0%	100.0%	0.0%	0.0%	0.0%	0.0%	0.0%	0.0%	0.0%	100.0%	100.0%	0.0%	0.0%	0.0%	0.0%	0.0%	100.0%	100.0%
Bicycles on Crosswalk	0	0	0	0	0	0	0	0	0	0	0	0	0	0	0	0	0	0	0	0	0	0	0	0	0	0	0	0	0
% Bicycles on Crosswalk	0.0%	0.0%	0.0%	0.0%	0.0%	0.0%	0.0%	0.0%	0.0%	0.0%	0.0%	0.0%	0.0%	0.0%	0.0%	0.0%	0.0%	0.0%	0.0%	0.0%	0.0%	0.0%	0.0%	0.0%	0.0%	0.0%	0.0%	0.0%	0.0%

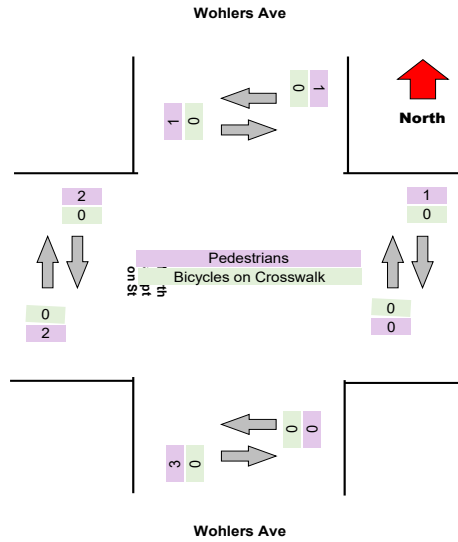
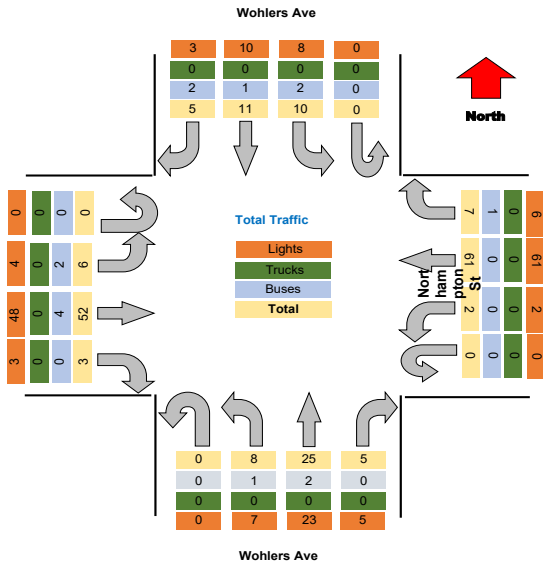

Turning Movement Peak Hour Data (PM)

4:15:00 PM

Leg Direction	Wohlers Ave										Northampton St										Total									
	Southbound					Westbound					Northbound					Eastbound														
	Right	Thru	Left	U-Turn	App Total	Peds CW	Peds CCW	Right	Thru	Left	U-Turn	App Total	Peds CW	Peds CCW	Right	Thru	Left	U-Turn	App Total	Peds CW		Peds CCW								
4:15:00 PM	2	8	6	0	16	0	0	3	20	3	0	26	1	0	5	17	0	0	22	0	0	4	18	3	0	25	0	0	89	
4:30:00 PM	0	10	5	0	15	2	0	6	18	0	0	24	1	1	2	19	2	0	23	0	1	3	22	1	0	26	0	0	88	
4:45:00 PM	2	8	3	0	13	4	0	4	21	1	0	26	0	0	3	15	6	0	24	0	0	1	22	1	0	24	5	1	87	
5:00:00 PM	3	2	1	0	6	0	0	1	16	1	0	18	0	0	1	19	3	0	23	0	0	0	21	1	0	22	0	0	69	
Grand Total	7	28	15	0	50	6	0	14	75	5	0	94	2	1	11	70	11	0	82	0	1	8	83	6	0	97	5	1	333	
% Approach	14.0%	56.0%	30.0%	0.0%	0.0%	0.0%	0.0%	14.5%	79.8%	5.3%	0.0%	0.0%	0.0%	0.0%	12.0%	76.1%	12.0%	0.0%	0.0%	0.0%	0.0%	0.0%	85.6%	6.2%	0.0%	0.0%	0.0%	0.0%	0.0%	0.0%
% Total	2.1%	8.4%	4.5%	0.0%	15.0%	0.0%	0.0%	4.2%	22.5%	1.5%	0.0%	28.2%	0.0%	0.0%	3.3%	21.0%	3.3%	0.0%	27.6%	0.0%	0.0%	2.4%	24.9%	1.8%	0.0%	29.1%	0.0%	0.0%	0.0%	
PHF	0.583	0.700	0.625	0.000	0.781	0.000	0.000	0.583	0.893	0.417	0.000	0.904	0.000	0.000	0.550	0.921	0.458	0.000	0.858	0.000	0.000	0.500	0.843	0.500	0.000	0.933	0.000	0.000	0.935	
Lights	5	27	13	0	45	0	0	13	74	5	0	92	0	0	10	70	11	0	91	0	0	7	80	6	0	93	0	0	321	
% Lights	71.4%	96.4%	86.7%	0.0%	90.0%	0.0%	0.0%	92.9%	98.7%	100.0%	0.0%	97.9%	0.0%	0.0%	80.9%	100.0%	100.0%	0.0%	98.9%	0.0%	0.0%	87.5%	96.4%	100.0%	0.0%	95.9%	0.0%	0.0%	96.4%	
Trucks	0	0	0	0	0	0	0	0	0	0	0	0	0	0	0	0	0	0	0	0	0	0	0	0	0	0	0	0	0	
% Trucks	0.0%	0.0%	0.0%	0.0%	0.0%	0.0%	0.0%	0.0%	0.0%	0.0%	0.0%	0.0%	0.0%	0.0%	0.0%	0.0%	0.0%	0.0%	0.0%	0.0%	0.0%	0.0%	0.0%	0.0%	0.0%	0.0%	0.0%	0.0%	0.0%	
Buses	2	1	2	0	5	0	0	1	1	0	0	2	0	0	1	0	0	0	1	0	0	1	3	0	0	4	0	0	12	
% Buses	28.6%	3.6%	13.3%	0.0%	0.0%	0.0%	0.0%	7.1%	1.3%	0.0%	0.0%	0.0%	0.0%	0.0%	9.1%	0.0%	0.0%	0.0%	0.0%	0.0%	0.0%	12.5%	3.6%	0.0%	0.0%	0.0%	0.0%	0.0%	3.6%	
Pedestrians	0	0	0	0	0	6	0	0	0	0	0	2	2	0	0	0	0	0	0	1	0	0	0	0	0	0	5	1	0	
% Pedestrians	0.0%	0.0%	0.0%	0.0%	0.0%	100.0%	0.0%	0.0%	0.0%	0.0%	0.0%	0.0%	100.0%	100.0%	0.0%	0.0%	0.0%	0.0%	0.0%	0.0%	0.0%	0.0%	0.0%	0.0%	0.0%	0.0%	0.0%	100.0%	100.0%	0.0%
Bicycles on Crosswalk	0	0	0	0	0	0	0	0	0	0	0	0	0	0	0	0	0	0	0	0	0	0	0	0	0	0	0	0	0	
% Bicycles on Crosswalk	0.0%	0.0%	0.0%	0.0%	0.0%	0.0%	0.0%	0.0%	0.0%	0.0%	0.0%	0.0%	0.0%	0.0%	0.0%	0.0%	0.0%	0.0%	0.0%	0.0%	0.0%	0.0%	0.0%	0.0%	0.0%	0.0%	0.0%	0.0%	0.0%	

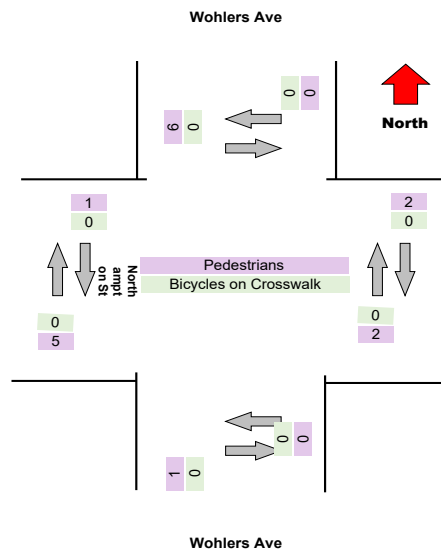
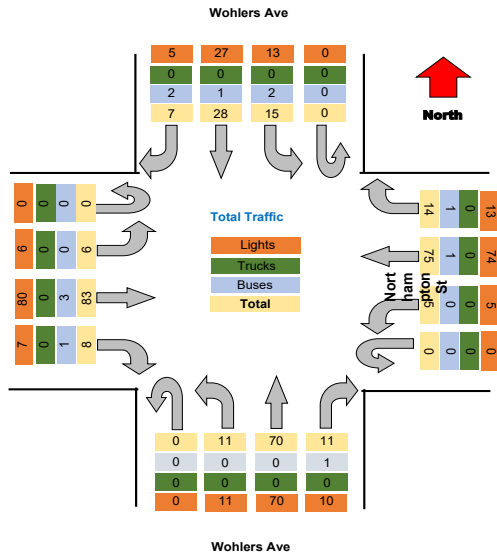

Project : VBH Malta NY
 Site : Site 4
 Location : 42.948550, -73.790036
 Survey Date : 2021-04-28, Wednesday

Turning Movement Data Plot

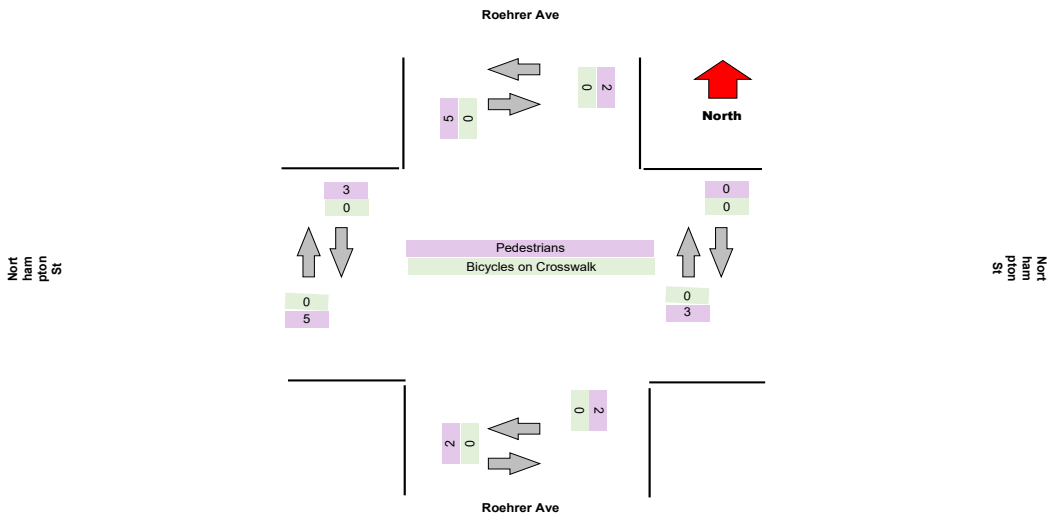
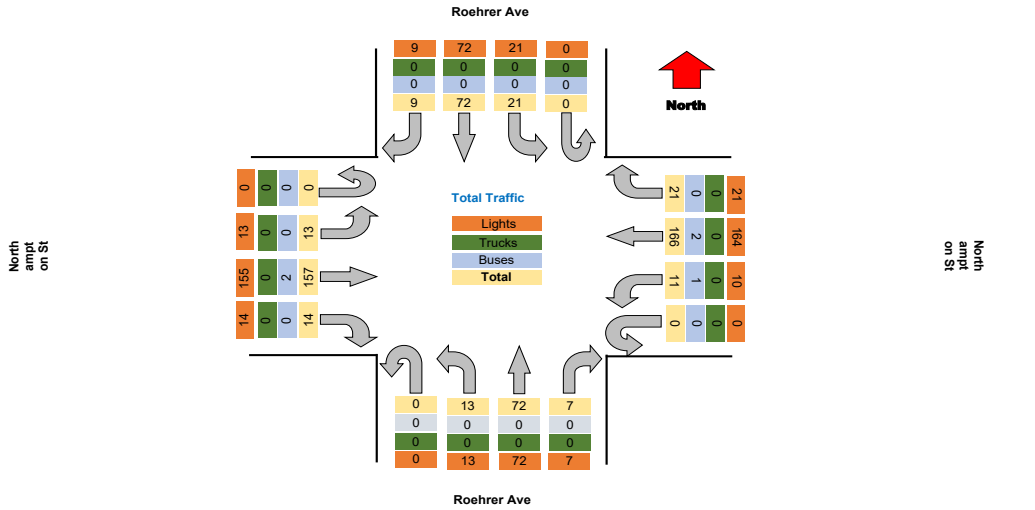

Project : VBH Malta NY
Site : Site 4
Location : 42.948550, -73.790036

TSTData.com

Survey Date : 2021-04-28, Wednesday

Turning Movement Peak Hour Data (AM)

7:30:00 AM

Leg Direction	Roehrer Ave						Northampton St						Roehrer Ave						Northampton St						Total					
	Southbound			Northbound			Westbound			Eastbound			Northbound			Eastbound														
Start Time	Right	Thru	Left	U-Turn	App Total	Peds CW	Peds CCW	Right	Thru	Left	U-Turn	App Total	Peds CW	Peds CCW	Right	Thru	Left	U-Turn	App Total	Peds CW	Peds CCW	Right	Thru	Left	U-Turn	App Total	Peds CW	Peds CCW		
7:30:00 AM	0	3	0	0	3	0	0	1	9	0	0	10	0	0	0	2	0	0	2	1	0	0	0	8	0	0	8	0	0	23
7:45:00 AM	0	3	0	0	3	0	0	1	9	1	0	11	0	0	0	6	3	0	9	0	0	0	1	10	1	0	12	0	0	35
8:00:00 AM	2	3	0	0	5	0	0	2	12	0	0	14	0	0	0	4	1	0	5	0	0	0	5	2	0	8	1	0	32	
8:15:00 AM	1	3	0	0	4	0	0	0	20	1	0	21	0	0	0	0	0	0	0	1	0	0	0	13	0	0	13	0	0	38
Grand Total	3	12	0	0	15	0	0	4	50	2	0	56	0	0	0	12	4	0	16	2	0	2	36	3	0	41	1	0	128	
% Approach	20.0%	80.0%	0.0%	0.0%	0.0%	0.0%	0.0%	7.1%	89.3%	3.6%	0.0%	0.0%	0.0%	0.0%	0.0%	75.0%	25.0%	0.0%	0.0%	0.0%	0.0%	4.9%	87.8%	7.3%	0.0%	0.0%	0.0%	0.0%	0.0%	
% Total	2.3%	9.4%	0.0%	0.0%	11.7%	0.0%	0.0%	3.1%	39.1%	1.6%	0.0%	43.8%	0.0%	0.0%	0.0%	9.4%	3.1%	0.0%	12.5%	0.0%	0.0%	1.6%	28.1%	2.3%	0.0%	32.0%	0.0%	0.0%	0.8%	
PHF	0.375	1.000	0.000	0.000	0.750	0.000	0.000	0.500	0.625	0.500	0.000	0.667	0.000	0.000	0.000	0.500	0.333	0.000	0.444	0.000	0.000	0.500	0.692	0.375	0.000	0.788	0.000	0.000	0.842	
Lights	3	12	0	0	15	0	0	4	50	2	0	56	0	0	0	12	4	0	16	0	0	2	36	3	0	40	0	0	127	
% Lights	100.0%	100.0%	0.0%	0.0%	100.0%	0.0%	0.0%	100.0%	100.0%	100.0%	0.0%	100.0%	0.0%	0.0%	0.0%	100.0%	100.0%	0.0%	100.0%	0.0%	0.0%	100.0%	97.2%	100.0%	0.0%	97.6%	0.0%	0.0%	99.2%	
Trucks	0	0	0	0	0	0	0	0	0	0	0	0	0	0	0	0	0	0	0	0	0	0	0	0	0	0	0	0	0	
% Trucks	0.0%	0.0%	0.0%	0.0%	0.0%	0.0%	0.0%	0.0%	0.0%	0.0%	0.0%	0.0%	0.0%	0.0%	0.0%	0.0%	0.0%	0.0%	0.0%	0.0%	0.0%	0.0%	0.0%	0.0%	0.0%	0.0%	0.0%	0.0%	0.0%	
Buses	0	0	0	0	0	0	0	0	0	0	0	0	0	0	0	0	0	0	0	0	0	0	1	0	0	1	0	0	1	
% Buses	0.0%	0.0%	0.0%	0.0%	0.0%	0.0%	0.0%	0.0%	0.0%	0.0%	0.0%	0.0%	0.0%	0.0%	0.0%	0.0%	0.0%	0.0%	0.0%	0.0%	0.0%	0.0%	2.8%	0.0%	0.0%	0.0%	0.0%	0.0%	0.8%	
Pedestrians	0	0	0	0	0	0	0	0	0	0	0	0	0	0	0	0	0	0	2	0	0	0	0	0	0	0	1	0	0	
% Pedestrians	0.0%	0.0%	0.0%	0.0%	0.0%	0.0%	0.0%	0.0%	0.0%	0.0%	0.0%	0.0%	0.0%	0.0%	0.0%	0.0%	0.0%	0.0%	0.0%	0.0%	0.0%	0.0%	0.0%	0.0%	0.0%	0.0%	0.0%	100.0%	0.0%	
Bicycles on Crosswalk	0	0	0	0	0	0	0	0	0	0	0	0	0	0	0	0	0	0	0	0	0	0	0	0	0	0	0	0	0	
% Bicycles on Crosswalk	0.0%	0.0%	0.0%	0.0%	0.0%	0.0%	0.0%	0.0%	0.0%	0.0%	0.0%	0.0%	0.0%	0.0%	0.0%	0.0%	0.0%	0.0%	0.0%	0.0%	0.0%	0.0%	0.0%	0.0%	0.0%	0.0%	0.0%	0.0%	0.0%	

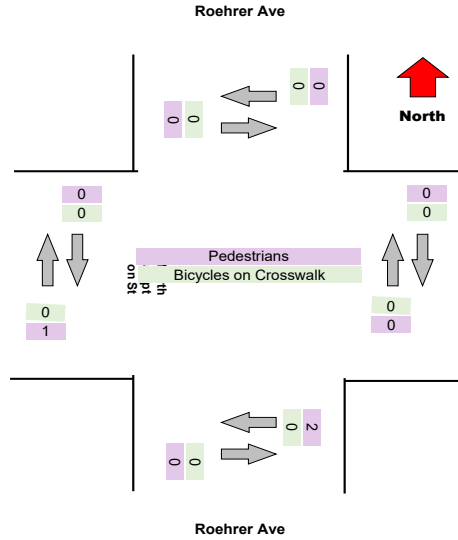
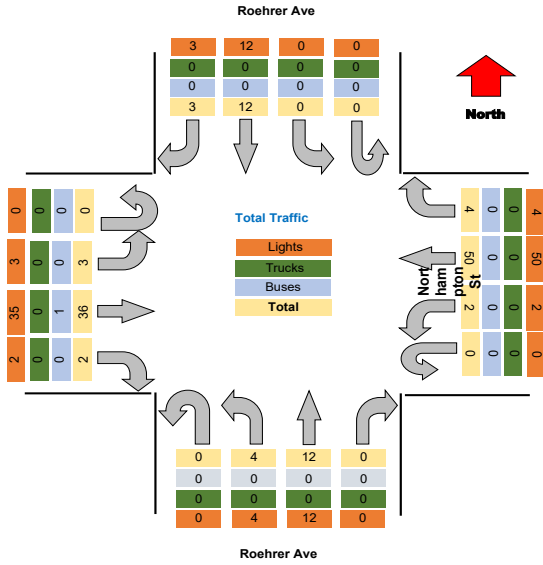

Turning Movement Peak Hour Data (PM)

4:30:00 PM

Leg Direction	Roehrer Ave				Northampton St				Roehrer Ave				Northampton St				Total												
	Southbound		Northbound		Westbound		Eastbound		Northbound		Southbound		Eastbound																
Start Time	Right	Thru	Left	U-Turn	App Total	Peds CW	Peds CCW	Right	Thru	Left	U-Turn	App Total	Peds CW	Peds CCW	Right	Thru	Left	U-Turn	App Total	Peds CW	Peds CCW								
4:30:00 PM	1	6	1	0	8	0	1	2	11	1	0	14	0	1	0	6	4	0	10	0	0	3	6	2	0	11	0	0	43
4:45:00 PM	0	7	4	0	11	1	0	2	13	2	0	17	0	0	1	8	1	0	10	0	0	0	23	1	0	24	0	0	62
5:00:00 PM	1	11	1	0	13	1	1	5	19	1	0	25	0	0	2	5	0	0	7	0	0	1	21	1	0	23	2	3	68
5:15:00 PM	1	8	1	0	10	0	0	2	16	0	0	18	0	1	1	4	0	0	5	0	2	0	8	3	0	11	0	0	44
Grand Total	3	32	7	0	42	2	2	11	59	4	0	74	0	2	4	23	5	0	32	0	2	4	58	7	0	59	2	3	217
% Approach	7.1%	76.2%	16.7%	0.0%	0.0%	0.0%	0.0%	14.5%	79.7%	5.4%	0.0%	0.0%	0.0%	0.0%	12.5%	71.9%	15.6%	0.0%	0.0%	0.0%	0.0%	5.8%	84.1%	10.1%	0.0%	0.0%	0.0%	0.0%	0.0%
% Total	1.4%	14.7%	3.2%	0.0%	19.4%	0.0%	0.0%	5.1%	27.2%	1.8%	0.0%	34.1%	0.0%	0.0%	1.8%	10.6%	2.3%	0.0%	14.7%	0.0%	0.0%	1.8%	26.7%	3.2%	0.0%	31.8%	0.0%	0.0%	0.0%
PHF	0.750	0.727	0.438	0.000	0.808	0.000	0.000	0.550	0.776	0.500	0.000	0.740	0.000	0.000	0.500	0.719	0.313	0.000	0.800	0.000	0.000	0.333	0.630	0.583	0.000	0.719	0.000	0.000	0.798
Lights	3	32	7	0	42	0	0	11	58	4	0	73	0	0	4	23	5	0	32	0	0	4	57	7	0	68	0	0	215
% Lights	100.0%	100.0%	100.0%	0.0%	100.0%	0.0%	0.0%	100.0%	98.3%	100.0%	0.0%	98.6%	0.0%	0.0%	100.0%	100.0%	100.0%	0.0%	100.0%	0.0%	0.0%	100.0%	98.3%	100.0%	0.0%	98.6%	0.0%	0.0%	99.1%
Trucks	0	0	0	0	0	0	0	0	0	0	0	0	0	0	0	0	0	0	0	0	0	0	0	0	0	0	0	0	0
% Trucks	0.0%	0.0%	0.0%	0.0%	0.0%	0.0%	0.0%	0.0%	0.0%	0.0%	0.0%	0.0%	0.0%	0.0%	0.0%	0.0%	0.0%	0.0%	0.0%	0.0%	0.0%	0.0%	0.0%	0.0%	0.0%	0.0%	0.0%	0.0%	0.0%
Buses	0	0	0	0	0	0	0	1	0	0	0	1	0	0	0	0	0	0	0	0	0	0	1	0	0	1	0	0	2
% Buses	0.0%	0.0%	0.0%	0.0%	0.0%	0.0%	0.0%	0.0%	1.7%	0.0%	0.0%	0.0%	0.0%	0.0%	0.0%	0.0%	0.0%	0.0%	0.0%	0.0%	0.0%	0.0%	1.7%	0.0%	0.0%	0.0%	0.0%	0.0%	0.9%
Pedestrians	0	0	0	0	0	2	2	0	0	0	0	0	2	0	0	0	0	0	0	0	2	0	0	0	0	0	2	3	0
% Pedestrians	0.0%	0.0%	0.0%	0.0%	0.0%	100.0%	100.0%	0.0%	0.0%	0.0%	0.0%	0.0%	100.0%	0.0%	0.0%	0.0%	0.0%	0.0%	0.0%	0.0%	0.0%	100.0%	0.0%	0.0%	0.0%	0.0%	0.0%	100.0%	0.0%
Bicycles on Crosswalk	0	0	0	0	0	0	0	0	0	0	0	0	0	0	0	0	0	0	0	0	0	0	0	0	0	0	0	0	0
% Bicycles on Crosswalk	0.0%	0.0%	0.0%	0.0%	0.0%	0.0%	0.0%	0.0%	0.0%	0.0%	0.0%	0.0%	0.0%	0.0%	0.0%	0.0%	0.0%	0.0%	0.0%	0.0%	0.0%	0.0%	0.0%	0.0%	0.0%	0.0%	0.0%	0.0%	0.0%

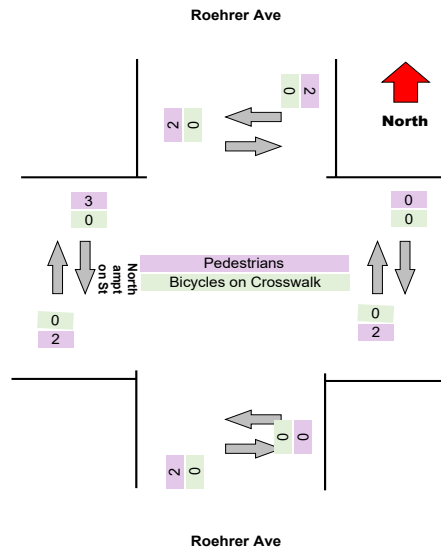
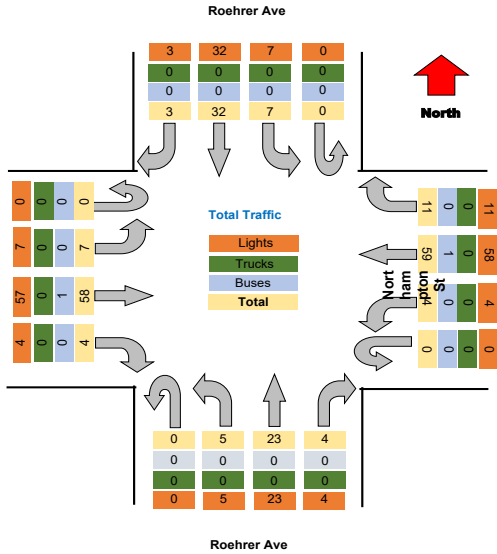

Project : VBH Malta NY
Site : Site 4
Location : 42.948550, -73.790036

TSTData.com

Survey Date : 2021-04-28, Wednesday

Project	LaBella
Project Code	LaBella
Site Name	S
Legs and Movements	All Processed Legs & Move
Bin Size	15 minutes
Survey Date	2021-11-03, Wednesday
Location	S
Latitude and Longitude	42.907387, -78.849134

	Start	End	PHF
Forced Peak AM	2021/11/03 07:30:00	2021/11/03 08:30:00	0.83
Forced Peak PM	2021/11/03 16:30:00	2021/11/03 17:30:00	0.81
AM Peak	2021/11/03 07:30:00	2021/11/03 08:30:00	0.83
PM Peak	2021/11/03 16:30:00	2021/11/03 17:30:00	0.81

Turning Movement Data

Leg Direction	Roehrer Ave								Northampton St								Roehrer Ave								Northampton St								Total
	Southbound				Westbound				Northbound				Eastbound				Southbound				Westbound				Northbound				Eastbound				
	Right	Thru	Left	U-Turn	App Total	Peds CV	Peds CCV		Right	Thru	Left	U-Turn	App Total	Peds CV	Peds CCV		Right	Thru	Left	U-Turn	App Total	Peds CV	Peds CCV		Right	Thru	Left	U-Turn	App Total	Peds CV	Peds CCV		
Start Time																																	
6:30:00 AM	0	2	0	0	2	1	0		1	4	0	0	5	0	0		0	4	1	0	5	0	0		0	2	0	0	2	0	0		14
6:45:00 AM	0	0	1	0	1	0	0		0	12	2	0	14	0	0		0	3	1	0	4	0	0		0	3	2	0	5	0	0		24
Hourly Total	0	2	1	0	3	1	0		1	16	2	0	19	0	0		0	7	2	0	9	0	0		0	5	2	0	7	0	0		38
7:00:00 AM	2	2	0	0	4	0	0		0	8	0	0	8	0	0		1	2	0	0	3	0	0		1	4	0	0	5	0	0		18
7:15:00 AM	1	3	1	0	5	0	0		1	8	1	0	10	0	0		0	2	2	0	4	0	0		1	5	1	0	7	1	0		28
7:30:00 AM	1	3	0	0	4	0	1		0	11	2	0	14	0	0		0	0	2	0	2	0	0		1	10	0	0	11	0	0		31
7:45:00 AM	0	7	1	0	8	1	0		1	17	1	0	19	0	0		2	3	2	0	7	0	0		1	14	0	0	15	1	1		49
Hourly Total	4	15	2	0	21	1	1		2	42	4	0	49	0	0		3	7	6	0	16	0	0		4	33	1	0	38	2	1		124
8:00:00 AM	1	5	3	0	9	0	1		0	12	0	0	13	0	0		0	6	1	0	7	0	0		0	9	0	0	9	0	0		38
8:15:00 AM	1	4	1	0	6	0	0		0	22	1	0	23	0	0		0	2	3	0	5	1	0		1	7	2	0	10	0	0		44
Hourly Total	2	9	4	0	15	0	1		0	34	1	0	36	0	0		0	8	4	0	12	1	0		1	16	2	0	19	0	0		82
4:00:00 PM	1	9	3	0	13	0	1		6	6	4	0	16	0	0		1	12	0	0	13	0	0		0	12	1	0	13	0	0		55
4:15:00 PM	1	10	3	0	14	0	0		2	18	2	0	22	1	0		3	6	0	0	9	0	0		3	16	3	0	22	0	2		67
4:30:00 PM	2	3	2	0	7	0	1		3	11	1	0	15	0	0		0	6	2	0	8	0	0		1	18	2	0	21	0	1		51
4:45:00 PM	0	9	1	0	10	0	0		6	18	0	0	24	0	0		2	5	0	0	7	0	0		3	12	1	0	16	0	0		57
Hourly Total	4	31	9	0	44	0	2		17	53	7	0	77	1	2		6	29	2	0	37	0	0		7	58	7	0	72	0	3		230
5:00:00 PM	3	4	2	0	9	1	0		2	10	3	0	15	0	0		3	4	1	0	8	0	1		1	15	1	0	17	0	0		49
5:15:00 PM	1	8	4	0	13	0	0		2	16	2	0	20	0	1		1	6	1	0	8	0	0		0	24	5	0	29	1	1		70
5:30:00 PM	1	5	3	0	9	0	1		1	7	1	0	9	3	0		0	6	0	0	6	1	0		1	18	1	0	20	0	1		44
5:45:00 PM	0	5	4	0	9	0	1		2	13	3	0	18	0	0		0	7	2	0	9	0	0		0	14	2	0	16	0	1		52
Hourly Total	5	22	13	0	40	1	2		7	46	9	0	62	3	1		4	23	4	0	31	1	1		2	71	9	0	82	1	3		215
Grand Total	15	79	29	0	123	3	6		27	191	23	0	243	4	3		13	74	18	0	105	2	1		14	183	21	0	218	3	7		689
% Approach	12.2%	64.2%	23.6%	0.0%	0.0%	0.0%	0.0%		11.1%	78.6%	9.5%	0.0%	0.0%	0.0%	0.0%		12.4%	70.5%	17.1%	0.0%	0.0%	0.0%	0.0%		6.4%	83.9%	9.6%	0.0%	0.0%	0.0%	0.0%		0.0%
% Total	2.2%	11.5%	4.2%	0.0%	17.9%	0.0%	0.0%		3.9%	27.7%	3.3%	0.0%	35.3%	0.0%	0.0%		1.9%	10.7%	2.6%	0.0%	15.2%	0.0%	0.0%		2.0%	26.6%	3.0%	0.0%	31.6%	0.0%	0.0%		0.0%
Lights	14	74	29	0	117	0	0		27	187	19	0	233	0	0		9	73	15	0	97	0	0		13	174	17	0	204	0	0		651
% Lights	93.3%	93.7%	100.0%	0.0%	85.1%	0.0%	0.0%		100.0%	97.9%	82.6%	0.0%	95.9%	0.0%	0.0%		69.2%	88.6%	83.3%	0.0%	92.4%	0.0%	0.0%		92.9%	95.1%	81.0%	0.0%	93.6%	0.0%	0.0%		94.6%
Trucks	0	0	0	0	0	0	0		0	0	0	0	0	0	0		0	0	0	0	0	0	0		0	0	0	0	0	0	0		0
% Trucks	0.0%	0.0%	0.0%	0.0%	0.0%	0.0%	0.0%		0.0%	0.0%	0.0%	0.0%	0.0%	0.0%	0.0%		0.0%	0.0%	0.0%	0.0%	0.0%	0.0%	0.0%		0.0%	0.0%	0.0%	0.0%	0.0%	0.0%	0.0%		0.0%
Buses	1	5	0	0	6	0	0		0	4	4	0	8	0	0		0	4	1	3	8	0	0		1	9	4	0	14	0	0		36
% Buses	6.7%	6.3%	0.0%	0.0%	0.0%	0.0%	0.0%		0.0%	2.1%	17.4%	0.0%	0.0%	0.0%	0.0%		0.0%	1.4%	16.7%	0.0%	0.0%	0.0%	0.0%		7.1%	4.9%	19.0%	0.0%	0.0%	0.0%	0.0%		5.2%
Pedestrians	0	0	0	0	0	3	6		0	0	0	0	0	4	3		0	0	0	0	0	2	1		0	0	0	0	0	3	7		0
% Pedestrians	0.0%	0.0%	0.0%	0.0%	0.0%	100.0%	100.0%		0.0%	0.0%	0.0%	0.0%	0.0%	100.0%	100.0%		0.0%	0.0%	0.0%	0.0%	0.0%	100.0%	100.0%		0.0%	0.0%	0.0%	0.0%	0.0%	100.0%	100.0%		0.0%
Bicycles on Crosswalk	0	0	0	0	0	0	0		0	0	0	0	0	0	0		0	0	0	0	0	0	0		0	0	0	0	0	0	0		0
% Bicycles on Crosswalk	0.0%	0.0%	0.0%	0.0%	0.0%	0.0%	0.0%		0.0%	0.0%	0.0%	0.0%	0.0%	0.0%	0.0%		0.0%	0.0%	0.0%	0.0%	0.0%	0.0%	0.0%		0.0%	0.0%	0.0%	0.0%	0.0%	0.0%	0.0%		0.0%

Project : VBH Malta NY
 Site : Site 4
 Location : 42.948550, -73.790036
 Survey Date : 2021-04-28, Wednesday

Turning Movement Data Plot

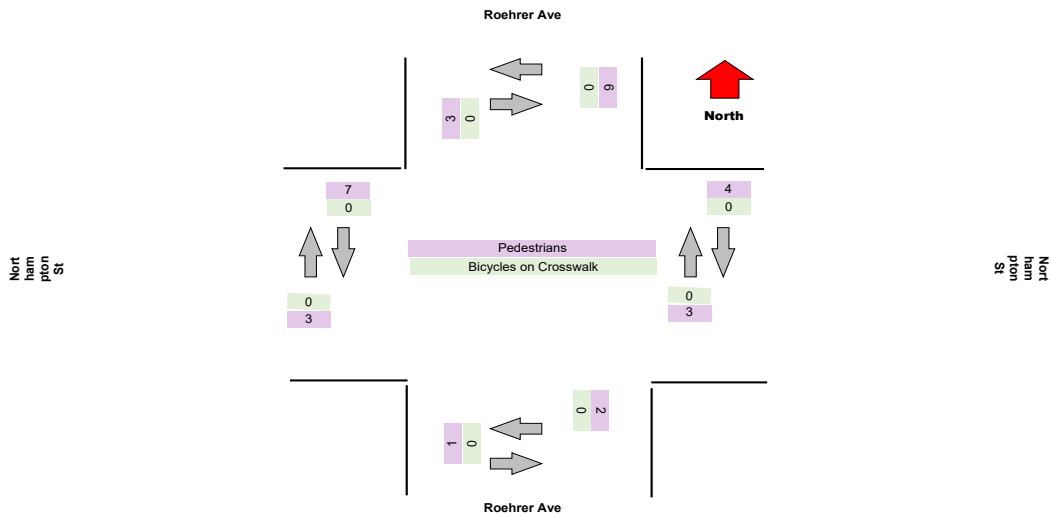
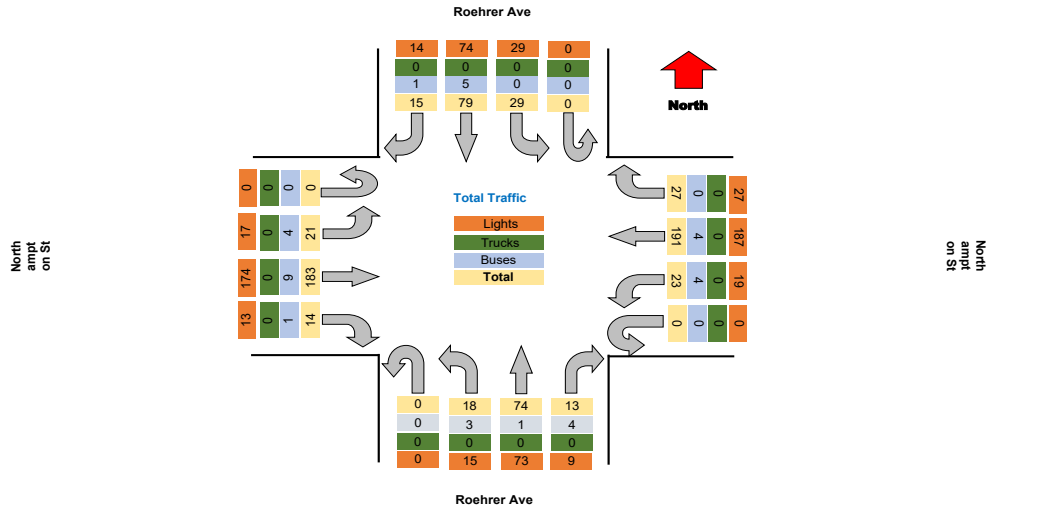

Turning Movement Peak Hour Data (AM)

7:30:00 AM

Leg Direction	Roehrer Ave				Northampton St				Roehrer Ave				Northampton St				Total					
	Southbound		Westbound		Northbound		Eastbound		Northbound		Eastbound		Eastbound									
Start Time	Right	Thru	Left	U-Turn	App Total	Peds CW	Peds CCW	Right	Thru	Left	U-Turn	App Total	Peds CW	Peds CCW	Right	Thru	Left	U-Turn	App Total	Peds CW	Peds CCW	
7:30:00 AM	1	3	0	0	4	0	1	0	11	2	0	14	0	0	0	2	0	0	2	0	0	0
7:45:00 AM	0	7	1	0	8	1	0	1	17	1	0	19	0	0	2	3	2	0	7	0	0	1
8:00:00 AM	1	5	3	0	9	0	1	0	12	0	0	13	0	0	0	6	1	0	7	0	0	0
8:15:00 AM	1	4	1	0	6	0	0	0	22	1	0	23	0	0	0	2	3	0	5	1	0	1
Grand Total	3	19	5	0	27	1	2	1	62	4	0	69	0	0	2	11	8	0	21	1	0	1
% Approach	11.1%	70.4%	18.5%	0.0%	0.0%	0.0%	0.0%	1.4%	89.9%	5.6%	0.0%	0.0%	0.0%	0.0%	9.5%	52.4%	38.1%	0.0%	0.0%	0.0%	0.0%	0.0%
% Total	1.9%	11.7%	3.1%	0.0%	16.7%	0.0%	0.0%	0.6%	38.3%	2.5%	0.0%	42.6%	0.0%	0.0%	1.2%	6.8%	4.9%	0.0%	13.0%	0.0%	0.0%	0.0%
PHF	0.750	0.679	0.417	0.000	0.750	0.000	0.000	0.250	0.705	0.500	0.000	0.750	0.000	0.000	0.250	0.458	0.667	0.000	0.750	0.000	0.000	0.000
Lights	3	18	5	0	26	0	0	1	61	3	0	65	0	0	1	11	7	0	19	0	0	1
% Lights	100.0%	94.7%	100.0%	0.0%	96.3%	0.0%	0.0%	100.0%	98.4%	75.0%	0.0%	94.2%	0.0%	0.0%	50.0%	100.0%	87.5%	0.0%	90.5%	0.0%	0.0%	100.0%
Trucks	0	0	0	0	0	0	0	0	0	0	0	0	0	0	0	0	0	0	0	0	0	0
% Trucks	0.0%	0.0%	0.0%	0.0%	0.0%	0.0%	0.0%	0.0%	0.0%	0.0%	0.0%	0.0%	0.0%	0.0%	0.0%	0.0%	0.0%	0.0%	0.0%	0.0%	0.0%	0.0%
Buses	0	1	0	0	1	0	0	0	1	1	0	2	0	0	1	0	1	0	2	0	0	0
% Buses	0.0%	5.3%	0.0%	0.0%	0.0%	0.0%	0.0%	0.0%	1.6%	25.0%	0.0%	0.0%	0.0%	0.0%	50.0%	0.0%	12.5%	0.0%	0.0%	0.0%	0.0%	0.0%
Pedestrians	0	0	0	0	0	1	2	0	0	0	0	0	0	0	0	0	0	0	0	1	1	0
% Pedestrians	0.0%	0.0%	0.0%	0.0%	0.0%	100.0%	100.0%	0.0%	0.0%	0.0%	0.0%	0.0%	0.0%	0.0%	0.0%	0.0%	0.0%	0.0%	0.0%	0.0%	100.0%	100.0%
Bicycles on Crosswalk	0	0	0	0	0	0	0	0	0	0	0	0	0	0	0	0	0	0	0	0	0	0
% Bicycles on Crosswalk	0.0%	0.0%	0.0%	0.0%	0.0%	0.0%	0.0%	0.0%	0.0%	0.0%	0.0%	0.0%	0.0%	0.0%	0.0%	0.0%	0.0%	0.0%	0.0%	0.0%	0.0%	0.0%

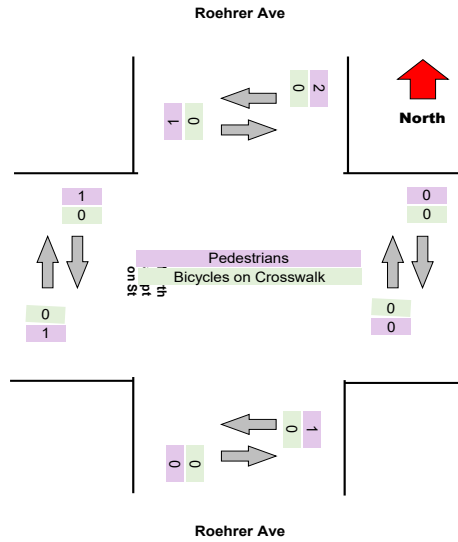
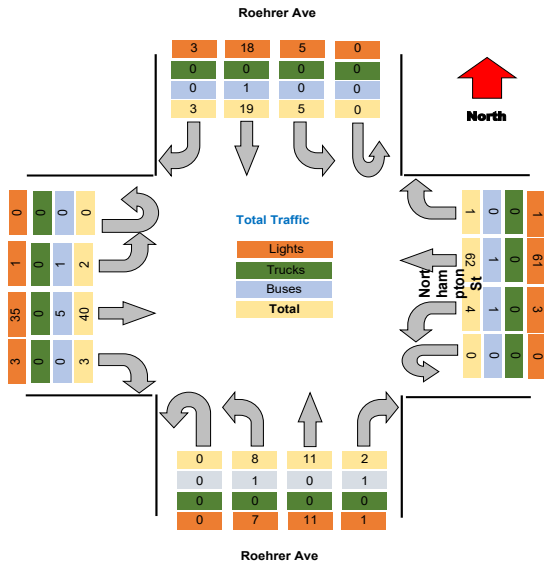

Turning Movement Peak Hour Data (PM)

4:30:00 PM

Leg Direction	Roehrer Ave				Northampton St				Roehrer Ave				Northampton St				Total													
	Southbound		Westbound		Northbound		Eastbound		Northbound		Eastbound		Eastbound																	
Start Time	Right	Thru	Left	U-Turn	App Total	Peds CW	Peds CCW	Right	Thru	Left	U-Turn	App Total	Peds CW	Peds CCW	Right	Thru	Left	U-Turn	App Total	Peds CW	Peds CCW									
4:30:00 PM	2	3	2	0	7	0	1	3	11	1	0	15	0	0	0	6	2	0	8	0	0	1	18	2	0	21	0	1	51	
4:45:00 PM	0	9	1	0	10	0	0	6	18	0	0	24	0	2	2	5	0	0	7	0	0	3	12	1	0	16	0	0	57	
5:00:00 PM	3	4	2	0	9	1	0	2	10	3	0	15	0	0	3	4	1	0	8	0	1	1	15	1	0	17	0	0	49	
5:15:00 PM	1	8	4	0	13	0	0	2	16	2	0	20	0	1	1	5	1	0	7	0	0	0	24	5	0	29	1	1	70	
Grand Total	6	24	9	0	39	1	1	13	55	6	0	74	0	3	6	21	4	0	31	0	1	5	69	9	0	83	1	2	227	
% Approach	15.4%	61.5%	23.1%	0.0%	0.0%	0.0%	0.0%	17.6%	74.3%	8.1%	0.0%	0.0%	0.0%	0.0%	19.4%	67.7%	12.9%	0.0%	0.0%	0.0%	0.0%	0.0%	6.0%	83.1%	10.8%	0.0%	0.0%	0.0%	0.0%	
% Total	2.6%	10.6%	4.0%	0.0%	17.2%	0.0%	0.0%	5.7%	24.2%	2.6%	0.0%	32.6%	0.0%	0.0%	2.6%	9.3%	1.8%	0.0%	13.7%	0.0%	0.0%	2.2%	30.4%	4.0%	0.0%	36.6%	0.0%	0.0%		
PHF	0.500	0.667	0.563	0.000	0.750	0.000	0.000	0.542	0.764	0.500	0.000	0.771	0.000	0.000	0.500	0.875	0.500	0.000	0.969	0.000	0.000	0.417	0.719	0.450	0.000	0.716	0.000	0.000	0.811	
Lights	5	22	9	0	36	0	0	13	54	4	0	71	0	0	5	21	2	0	28	0	0	5	68	7	0	80	0	0	215	
% Lights	83.3%	91.7%	100.0%	0.0%	92.3%	0.0%	0.0%	100.0%	98.2%	66.7%	0.0%	95.9%	0.0%	0.0%	83.3%	100.0%	50.0%	0.0%	90.3%	0.0%	0.0%	100.0%	98.6%	77.8%	0.0%	96.4%	0.0%	0.0%	94.7%	
Trucks	0	0	0	0	0	0	0	0	0	0	0	0	0	0	0	0	0	0	0	0	0	0	0	0	0	0	0	0	0	
% Trucks	0.0%	0.0%	0.0%	0.0%	0.0%	0.0%	0.0%	0.0%	0.0%	0.0%	0.0%	0.0%	0.0%	0.0%	0.0%	0.0%	0.0%	0.0%	0.0%	0.0%	0.0%	0.0%	0.0%	0.0%	0.0%	0.0%	0.0%	0.0%	0.0%	
Buses	1	2	0	0	3	0	0	0	1	2	0	3	0	0	1	0	2	0	3	0	0	0	1	2	0	3	0	0	12	
% Buses	16.7%	8.3%	0.0%	0.0%	0.0%	0.0%	0.0%	0.0%	1.8%	33.3%	0.0%	0.0%	0.0%	0.0%	16.7%	0.0%	50.0%	0.0%	0.0%	0.0%	0.0%	0.0%	1.4%	22.2%	0.0%	0.0%	0.0%	0.0%	5.3%	
Pedestrians	0	0	0	0	0	1	1	0	0	0	0	0	3	0	0	0	0	1	0	0	0	0	0	0	0	0	0	1	2	0
% Pedestrians	0.0%	0.0%	0.0%	0.0%	0.0%	100.0%	100.0%	0.0%	0.0%	0.0%	0.0%	0.0%	100.0%	0.0%	0.0%	0.0%	0.0%	0.0%	0.0%	0.0%	0.0%	0.0%	0.0%	0.0%	0.0%	0.0%	0.0%	100.0%	100.0%	0.0%
Bicycles on Crosswalk	0	0	0	0	0	0	0	0	0	0	0	0	0	0	0	0	0	0	0	0	0	0	0	0	0	0	0	0	0	
% Bicycles on Crosswalk	0.0%	0.0%	0.0%	0.0%	0.0%	0.0%	0.0%	0.0%	0.0%	0.0%	0.0%	0.0%	0.0%	0.0%	0.0%	0.0%	0.0%	0.0%	0.0%	0.0%	0.0%	0.0%	0.0%	0.0%	0.0%	0.0%	0.0%	0.0%	0.0%	

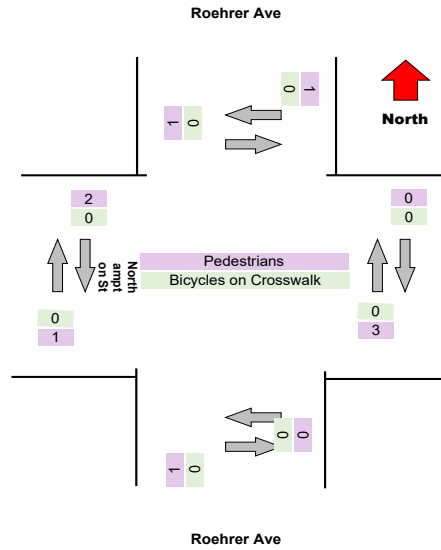
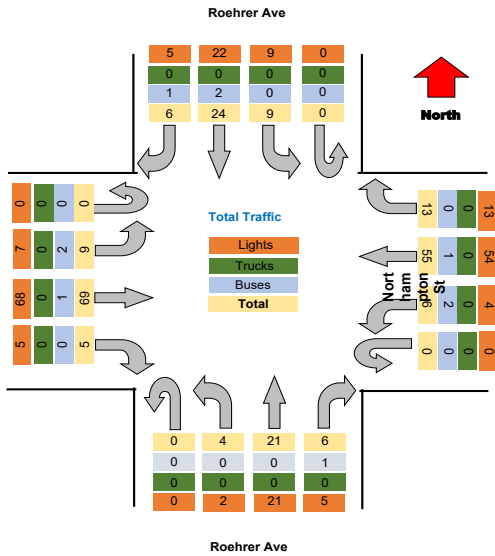

Project : VBH Malta NY
 Site : Site 4
 Location : 42.948550, -73.790036
 Survey Date : 2021-04-28, Wednesday

Turning Movement Data Plot

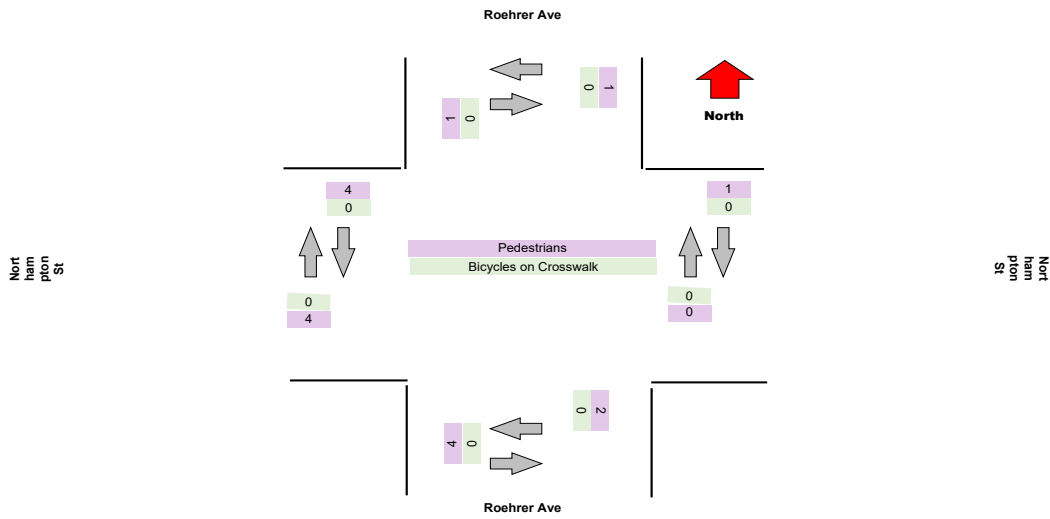
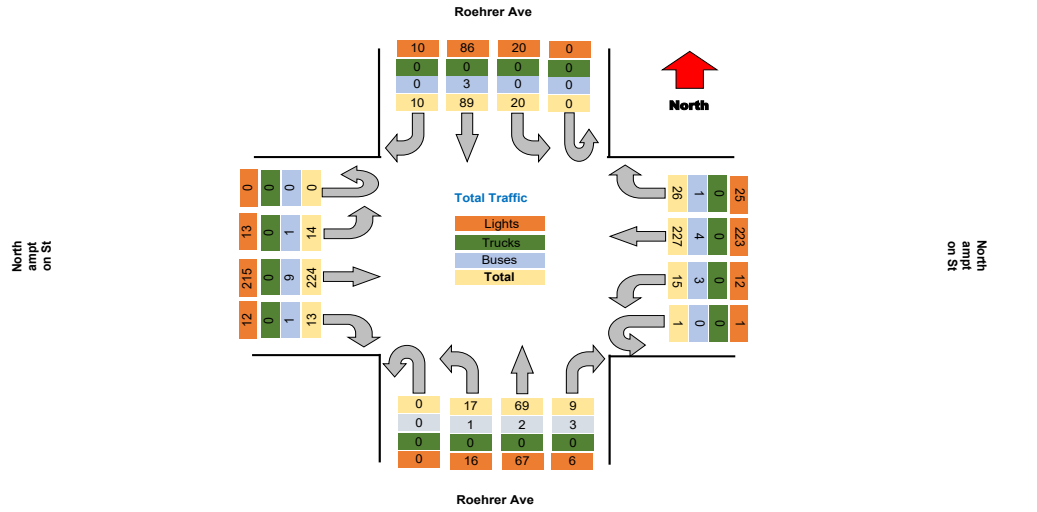

Turning Movement Peak Hour Data (AM)

7:30:00 AM

Leg Direction	Roehrer Ave						Northampton St						Roehrer Ave						Northampton St						Total				
	Southbound			Northbound			Westbound			Eastbound			Northbound			Eastbound													
Start Time	Right	Thru	Left	U-Turn	App Total	Peds CW	Peds CCW	Right	Thru	Left	U-Turn	App Total	Peds CW	Peds CCW	Right	Thru	Left	U-Turn	App Total	Peds CW	Peds CCW	Right	Thru	Left	U-Turn	App Total	Peds CW	Peds CCW	
7:30:00 AM	0	3	1	0	4	0	0	1	11	1	0	14	0	0	0	3	1	0	4	0	0	0	9	0	0	9	0	0	31
7:45:00 AM	0	4	2	0	6	0	0	2	15	1	0	18	0	0	2	3	0	0	5	0	0	1	17	0	0	18	1	0	47
8:00:00 AM	0	4	1	0	5	0	0	1	17	0	0	18	1	0	0	3	2	0	6	0	2	0	11	0	0	11	1	0	40
8:15:00 AM	0	2	0	0	2	0	0	0	24	1	0	25	0	0	0	4	1	0	5	1	0	1	16	0	0	19	0	0	51
Grand Total	0	13	4	0	17	0	0	4	67	3	0	75	1	0	2	13	4	0	20	1	2	2	55	0	0	57	2	0	169
% Approach	0.0%	76.5%	23.5%	0.0%	0.0%	0.0%	0.0%	5.3%	89.3%	4.0%	0.0%	0.0%	0.0%	0.0%	10.0%	65.0%	20.0%	0.0%	0.0%	0.0%	0.0%	3.5%	95.5%	0.0%	0.0%	0.0%	0.0%	0.0%	0.0%
% Total	0.0%	7.7%	2.4%	0.0%	10.1%	0.0%	0.0%	2.4%	39.6%	1.8%	0.0%	44.4%	0.0%	0.0%	1.2%	7.7%	2.4%	0.0%	11.8%	0.0%	0.0%	1.2%	32.5%	0.0%	0.0%	33.7%	0.0%	0.0%	6.5%
PHF	0.000	0.813	0.500	0.000	0.708	0.000	0.000	0.500	0.698	0.750	0.000	0.750	0.000	0.000	0.250	0.813	0.500	0.000	0.833	0.000	0.000	0.500	0.764	0.000	0.000	0.750	0.000	0.000	0.828
Lights	0	12	4	0	16	0	0	4	65	2	0	71	0	0	1	13	3	0	17	0	0	2	50	0	0	52	0	0	156
% Lights	0.0%	92.3%	100.0%	0.0%	94.1%	0.0%	0.0%	100.0%	97.0%	66.7%	0.0%	94.7%	0.0%	0.0%	50.0%	100.0%	75.0%	0.0%	85.0%	0.0%	0.0%	100.0%	90.9%	0.0%	0.0%	91.2%	0.0%	0.0%	92.3%
Trucks	0	0	0	0	0	0	0	0	0	0	0	0	0	0	0	0	0	0	0	0	0	0	0	0	0	0	0	0	0
% Trucks	0.0%	0.0%	0.0%	0.0%	0.0%	0.0%	0.0%	0.0%	0.0%	0.0%	0.0%	0.0%	0.0%	0.0%	0.0%	0.0%	0.0%	0.0%	0.0%	0.0%	0.0%	0.0%	0.0%	0.0%	0.0%	0.0%	0.0%	0.0%	0.0%
Buses	0	1	0	0	1	0	0	0	2	1	0	3	0	0	1	0	1	0	2	0	0	0	5	0	0	5	0	0	11
% Buses	0.0%	7.7%	0.0%	0.0%	0.0%	0.0%	0.0%	0.0%	3.0%	33.3%	0.0%	0.0%	0.0%	0.0%	50.0%	0.0%	25.0%	0.0%	0.0%	0.0%	0.0%	0.0%	9.1%	0.0%	0.0%	0.0%	0.0%	0.0%	6.5%
Pedestrians	0	0	0	0	0	0	1	0	0	0	0	0	1	2	0	0	0	0	0	0	0	0	0	0	0	0	2	0	0
% Pedestrians	0.0%	0.0%	0.0%	0.0%	0.0%	100.0%	100.0%	0.0%	0.0%	0.0%	0.0%	0.0%	100.0%	100.0%	0.0%	0.0%	0.0%	0.0%	0.0%	0.0%	100.0%	100.0%	0.0%	0.0%	0.0%	0.0%	0.0%	100.0%	0.0%
Bicycles on Crosswalk	0	0	0	0	0	0	0	0	0	0	0	0	0	0	0	0	0	0	0	0	0	0	0	0	0	0	0	0	0
% Bicycles on Crosswalk	0.0%	0.0%	0.0%	0.0%	0.0%	0.0%	0.0%	0.0%	0.0%	0.0%	0.0%	0.0%	0.0%	0.0%	0.0%	0.0%	0.0%	0.0%	0.0%	0.0%	0.0%	0.0%	0.0%	0.0%	0.0%	0.0%	0.0%	0.0%	0.0%

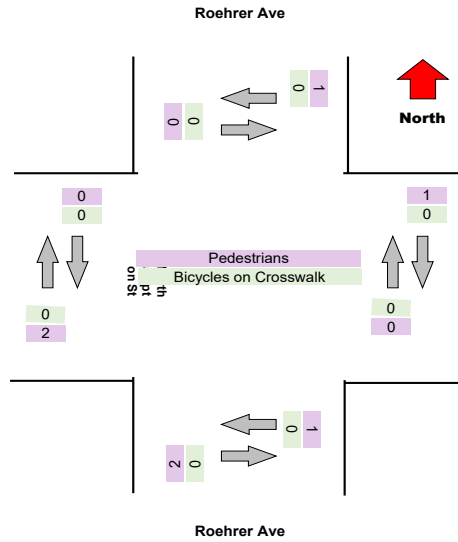
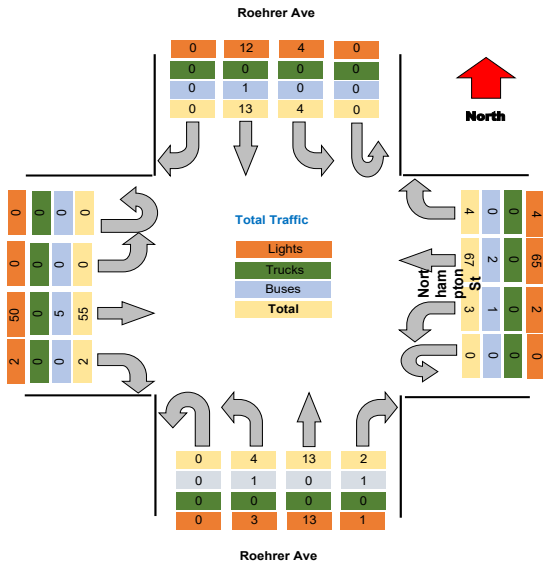

Turning Movement Peak Hour Data (PM)

4:30:00 PM

Leg Direction	Roehrer Ave					Northampton St					Roehrer Ave					Northampton St					Total									
	Southbound					Westbound					Northbound					Eastbound														
Start Time	Right	Thru	Left	U-Turn	App Total	Peds CW	Peds CCW	Right	Thru	Left	U-Turn	App Total	Peds CW	Peds CCW	Right	Thru	Left	U-Turn	App Total	Peds CW	Peds CCW	Right	Thru	Left	U-Turn	App Total	Peds CW	Peds CCW		
4:30:00 PM	0	9	3	0	12	0	0	2	21	0	0	23	0	0	0	8	1	0	9	0	0	1	1	22	0	0	23	0	0	67
4:45:00 PM	1	5	2	0	8	0	0	5	21	1	0	27	0	0	1	5	3	0	9	0	0	2	21	2	0	25	0	0	69	
5:00:00 PM	1	10	2	0	13	0	0	3	17	2	0	22	0	0	0	6	0	0	6	0	0	2	20	1	0	23	0	0	64	
5:15:00 PM	0	9	1	0	10	0	0	2	16	2	0	20	0	0	0	3	1	0	4	0	0	0	18	2	0	20	1	0	54	
Grand Total	2	33	8	0	43	0	0	12	75	5	0	92	0	0	1	22	5	0	28	0	0	5	81	5	0	91	1	0	254	
% Approach	4.7%	76.7%	18.6%	0.0%	0.0%	0.0%	0.0%	13.0%	81.5%	5.4%	0.0%	0.0%	0.0%	0.0%	3.6%	76.6%	17.9%	0.0%	0.0%	0.0%	0.0%	5.5%	89.0%	5.5%	0.0%	0.0%	0.0%	0.0%	0.0%	
% Total	0.8%	13.0%	3.1%	0.0%	16.9%	0.0%	0.0%	4.7%	29.5%	2.0%	0.0%	36.2%	0.0%	0.0%	0.4%	8.7%	2.0%	0.0%	11.0%	0.0%	0.0%	2.0%	31.9%	2.0%	0.0%	35.8%	0.0%	0.0%	0.0%	
PHF	0.500	0.825	0.667	0.000	0.827	0.000	0.000	0.600	0.893	0.625	0.000	0.852	0.000	0.000	0.250	0.688	0.417	0.000	0.778	0.000	0.000	0.625	0.920	0.625	0.000	0.910	0.000	0.000	0.920	
Lights	2	32	8	0	42	0	0	11	73	4	0	88	0	0	1	22	5	0	28	0	0	5	80	5	0	90	0	0	248	
% Lights	100.0%	97.0%	100.0%	0.0%	97.7%	0.0%	0.0%	81.7%	97.3%	80.0%	0.0%	95.7%	0.0%	0.0%	100.0%	100.0%	100.0%	0.0%	100.0%	0.0%	0.0%	100.0%	98.8%	100.0%	0.0%	98.9%	0.0%	0.0%	97.6%	
Trucks	0	0	0	0	0	0	0	0	0	0	0	0	0	0	0	0	0	0	0	0	0	0	0	0	0	0	0	0	0	
% Trucks	0.0%	0.0%	0.0%	0.0%	0.0%	0.0%	0.0%	0.0%	0.0%	0.0%	0.0%	0.0%	0.0%	0.0%	0.0%	0.0%	0.0%	0.0%	0.0%	0.0%	0.0%	0.0%	0.0%	0.0%	0.0%	0.0%	0.0%	0.0%	0.0%	
Buses	0	1	0	0	1	0	0	1	2	1	0	4	0	0	0	0	0	0	0	0	0	0	1	0	0	1	0	0	6	
% Buses	0.0%	3.0%	0.0%	0.0%	0.0%	0.0%	0.0%	8.3%	2.7%	20.0%	0.0%	0.0%	0.0%	0.0%	0.0%	0.0%	0.0%	0.0%	0.0%	0.0%	0.0%	0.0%	1.2%	0.0%	0.0%	0.0%	0.0%	0.0%	2.4%	
Pedestrians	0	0	0	0	0	0	0	0	0	0	0	0	0	0	0	0	0	0	1	0	0	0	0	0	0	0	1	0	0	
% Pedestrians	0.0%	0.0%	0.0%	0.0%	0.0%	0.0%	0.0%	0.0%	0.0%	0.0%	0.0%	0.0%	0.0%	0.0%	0.0%	0.0%	0.0%	0.0%	0.0%	0.0%	0.0%	0.0%	0.0%	0.0%	0.0%	0.0%	0.0%	100.0%	0.0%	
Bicycles on Crosswalk	0	0	0	0	0	0	0	0	0	0	0	0	0	0	0	0	0	0	0	0	0	0	0	0	0	0	0	0	0	
% Bicycles on Crosswalk	0.0%	0.0%	0.0%	0.0%	0.0%	0.0%	0.0%	0.0%	0.0%	0.0%	0.0%	0.0%	0.0%	0.0%	0.0%	0.0%	0.0%	0.0%	0.0%	0.0%	0.0%	0.0%	0.0%	0.0%	0.0%	0.0%	0.0%	0.0%	0.0%	

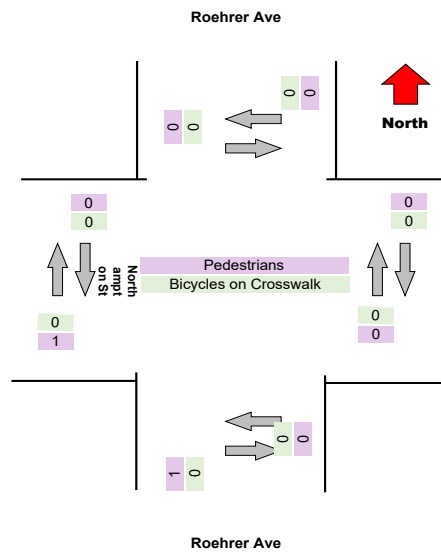
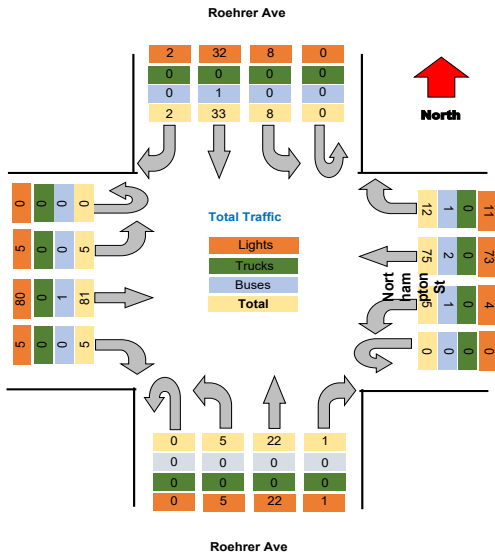

Project : VBH Malta NY
 Site : Site 4
 Location : 42.948550, -73.790036
 Survey Date : 2021-04-28, Wednesday

Turning Movement Data Plot

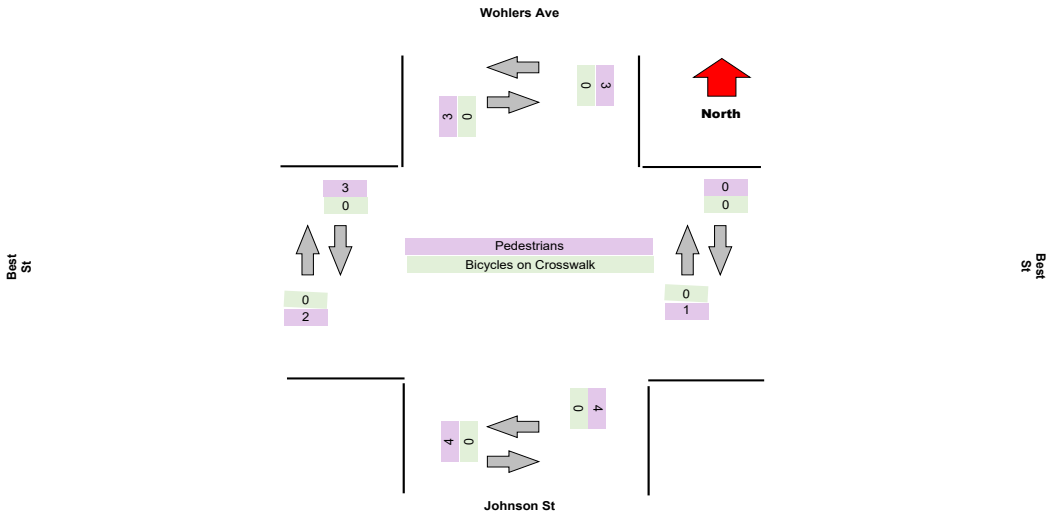
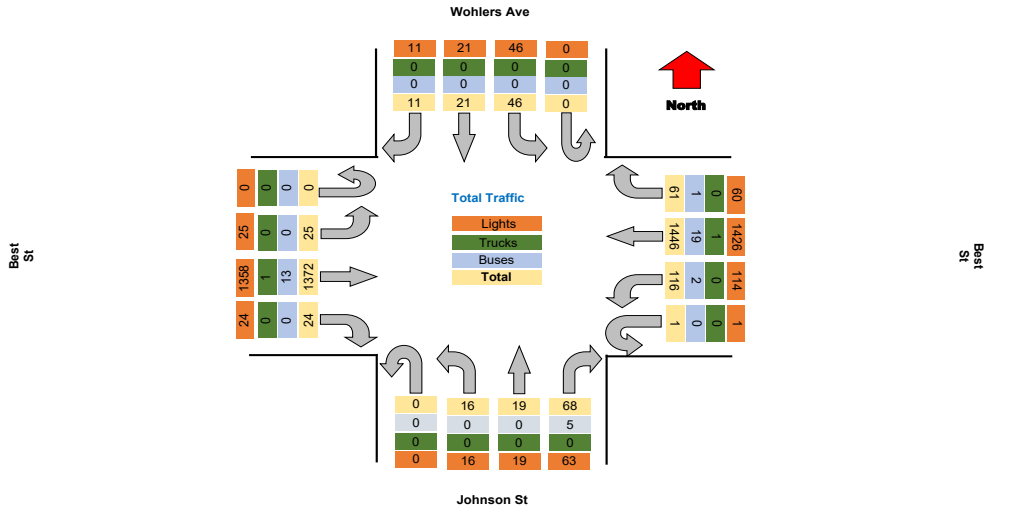

Project : VBH Malta NY
Site : Site 4
Location : 42.948550, -73.790036

TSTData.com

Survey Date : 2021-04-28, Wednesday

Turning Movement Peak Hour Data (AM)

7:30:00 AM

Leg Direction	Wohlers Ave						Best St						Johnson St						Best St						Total			
	Southbound			Westbound			Northbound			Eastbound			Northbound			Eastbound												
Start Time	Right	Thru	Left	U-Turn	App Total	Peds CW	Peds CCW	Right	Thru	Left	U-Turn	App Total	Peds CW	Peds CCW	Right	Thru	Left	U-Turn	App Total	Peds CW	Peds CCW	Right	Thru	Left	U-Turn	App Total	Peds CW	Peds CCW
7:30:00 AM	0	0	3	0	3	0	0	1	91	4	0	96	0	0	2	0	0	0	2	0	0	74	0	0	0	74	0	0
7:45:00 AM	0	2	5	0	7	0	0	1	107	10	0	118	0	0	12	1	2	0	15	0	0	2	65	3	0	70	0	0
8:00:00 AM	0	0	1	0	1	0	1	1	89	10	0	101	0	0	8	1	0	0	9	1	0	2	57	0	0	59	0	0
8:15:00 AM	1	0	1	0	2	0	0	4	101	14	0	115	0	0	1	1	1	0	3	0	1	0	59	0	0	59	0	0
Grand Total	1	2	10	0	13	0	1	7	388	38	0	424	0	0	23	3	3	0	29	1	1	5	254	3	0	257	3	0
% Approach	7.7%	15.4%	76.9%	0.0%	0.0%	0.0%	0.0%	1.6%	88.4%	8.8%	0.0%	0.0%	0.0%	0.0%	79.3%	10.3%	10.3%	0.0%	0.0%	0.0%	0.0%	1.9%	96.9%	1.1%	0.0%	0.0%	0.0%	0.0%
% Total	0.1%	0.3%	1.4%	0.0%	1.8%	0.0%	0.0%	0.9%	52.6%	5.1%	0.0%	58.8%	0.0%	0.0%	3.1%	0.4%	0.4%	0.0%	3.9%	0.0%	0.0%	0.7%	34.4%	0.4%	0.0%	35.5%	0.0%	0.0%
PHF	0.250	0.250	0.500	0.000	0.464	0.000	0.000	0.438	0.907	0.679	0.000	0.912	0.000	0.000	0.479	0.750	0.375	0.000	0.483	0.000	0.000	0.625	0.870	0.250	0.000	0.885	0.000	0.000
Lights	1	2	10	0	13	0	0	7	379	36	0	422	0	0	21	3	3	0	27	0	0	5	248	3	0	256	0	0
% Lights	100.0%	100.0%	100.0%	0.0%	100.0%	0.0%	0.0%	100.0%	97.7%	94.7%	0.0%	97.2%	0.0%	0.0%	81.3%	100.0%	100.0%	0.0%	93.1%	0.0%	0.0%	100.0%	97.6%	100.0%	0.0%	97.7%	0.0%	0.0%
Trucks	0	0	0	0	0	0	0	0	0	0	0	0	0	0	0	0	0	0	0	0	0	0	1	0	0	1	0	0
% Trucks	0.0%	0.0%	0.0%	0.0%	0.0%	0.0%	0.0%	0.0%	0.0%	0.0%	0.0%	0.0%	0.0%	0.0%	0.0%	0.0%	0.0%	0.0%	0.0%	0.0%	0.0%	0.0%	0.4%	0.0%	0.0%	0.4%	0.0%	0.0%
Buses	0	0	0	0	0	0	0	0	9	2	0	11	0	0	2	0	0	0	2	0	0	0	5	0	0	5	0	0
% Buses	0.0%	0.0%	0.0%	0.0%	0.0%	0.0%	0.0%	0.0%	2.3%	5.3%	0.0%	0.0%	0.0%	0.0%	8.7%	0.0%	0.0%	0.0%	0.0%	0.0%	0.0%	0.0%	2.0%	0.0%	0.0%	0.0%	0.0%	0.0%
Pedestrians	0	0	0	0	0	0	1	0	0	0	0	0	0	0	0	1	1	0	0	0	0	0	0	0	0	0	0	0
% Pedestrians	0.0%	0.0%	0.0%	0.0%	0.0%	100.0%	100.0%	0.0%	0.0%	0.0%	0.0%	0.0%	0.0%	0.0%	0.0%	0.0%	0.0%	0.0%	0.0%	0.0%	100.0%	100.0%	0.0%	0.0%	0.0%	0.0%	0.0%	0.0%
Bicycles on Crosswalk	0	0	0	0	0	0	0	0	0	0	0	0	0	0	0	0	0	0	0	0	0	0	0	0	0	0	0	0
% Bicycles on Crosswalk	0.0%	0.0%	0.0%	0.0%	0.0%	0.0%	0.0%	0.0%	0.0%	0.0%	0.0%	0.0%	0.0%	0.0%	0.0%	0.0%	0.0%	0.0%	0.0%	0.0%	0.0%	0.0%	0.0%	0.0%	0.0%	0.0%	0.0%	0.0%

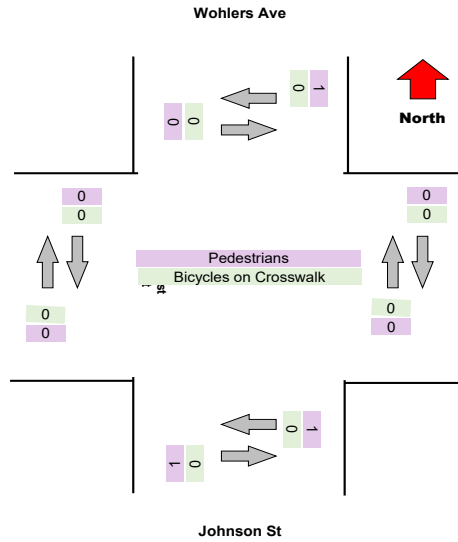
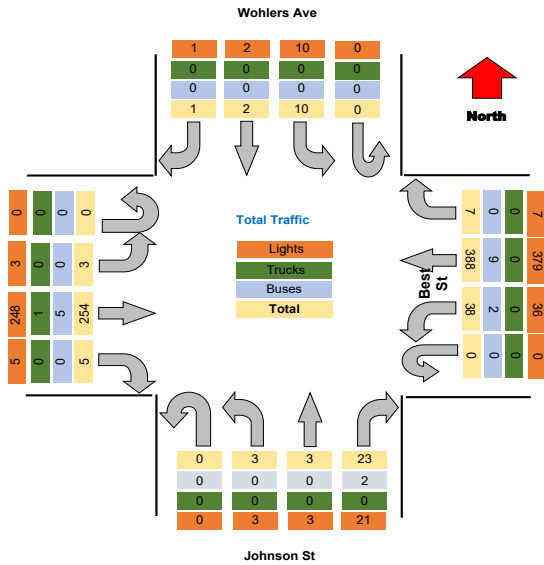

Turning Movement Peak Hour Data (PM)

4:15:00 PM

Leg Direction	Wohlers Ave						Best St						Johnson St						Best St						Total					
	Southbound			Westbound			Northbound			Eastbound			Northbound			Eastbound														
Start Time	Right	Thru	Left	U-Turn	App Total	Peds CW	Peds CCW	Right	Thru	Left	U-Turn	App Total	Peds CW	Peds CCW	Right	Thru	Left	U-Turn	App Total	Peds CW	Peds CCW	Right	Thru	Left	U-Turn	App Total	Peds CW	Peds CCW		
4:15:00 PM	0	3	1	0	4	1	0	6	92	10	0	108	0	0	2	1	1	0	4	0	1	8	124	3	0	135	0	0	251	
4:30:00 PM	2	3	4	0	9	1	0	8	98	19	0	125	0	0	19	0	1	0	20	0	1	2	124	3	0	129	2	0	283	
4:45:00 PM	0	2	5	0	7	0	0	2	94	12	0	108	0	0	4	4	2	0	10	0	0	1	107	5	0	113	0	0	238	
5:00:00 PM	2	2	1	0	5	0	0	6	88	5	0	109	0	0	2	2	1	0	5	0	0	0	144	3	0	144	0	0	283	
Grand Total	4	10	11	0	25	2	0	22	382	46	0	450	0	0	27	7	5	0	39	0	2	11	493	14	0	521	2	0	1035	
% Approach	16.0%	40.0%	44.0%	0.0%	0.0%	0.0%	0.0%	4.9%	84.9%	10.2%	0.0%	0.0%	0.0%	0.0%	89.2%	17.9%	12.8%	0.0%	0.0%	0.0%	0.0%	2.1%	95.2%	2.7%	0.0%	0.0%	0.0%	0.0%	0.0%	
% Total	0.4%	1.0%	1.1%	0.0%	2.4%	0.0%	0.0%	2.1%	36.9%	4.4%	0.0%	43.5%	0.0%	0.0%	2.6%	0.7%	0.5%	0.0%	3.8%	0.0%	0.0%	1.1%	47.9%	1.4%	0.0%	50.3%	0.0%	0.0%	0.0%	
PHF	0.500	0.833	0.550	0.000	0.694	0.000	0.000	0.688	0.974	0.605	0.000	0.900	0.000	0.000	0.355	0.438	0.625	0.000	0.488	0.000	0.000	0.344	0.879	0.700	0.000	0.905	0.000	0.000	0.914	
Lights	4	10	11	0	25	0	0	21	379	46	0	446	0	0	25	7	5	0	37	0	0	11	493	14	0	518	0	0	1026	
% Lights	100.0%	100.0%	100.0%	0.0%	100.0%	0.0%	0.0%	95.5%	99.2%	100.0%	0.0%	99.1%	0.0%	0.0%	92.6%	100.0%	100.0%	0.0%	94.9%	0.0%	0.0%	100.0%	99.4%	100.0%	0.0%	99.4%	0.0%	0.0%	99.1%	
Trucks	0	0	0	0	0	0	0	0	0	0	0	0	0	0	0	0	0	0	0	0	0	0	0	0	0	0	0	0	0	
% Trucks	0.0%	0.0%	0.0%	0.0%	0.0%	0.0%	0.0%	0.0%	0.0%	0.0%	0.0%	0.0%	0.0%	0.0%	0.0%	0.0%	0.0%	0.0%	0.0%	0.0%	0.0%	0.0%	0.0%	0.0%	0.0%	0.0%	0.0%	0.0%	0.0%	
Buses	0	0	0	0	0	0	0	1	3	0	0	4	0	0	2	0	0	0	2	0	0	0	3	0	0	3	0	0	9	
% Buses	0.0%	0.0%	0.0%	0.0%	0.0%	0.0%	0.0%	4.5%	0.8%	0.0%	0.0%	0.9%	0.0%	0.0%	7.4%	0.0%	0.0%	0.0%	0.0%	0.0%	0.0%	0.0%	0.6%	0.0%	0.0%	0.0%	0.0%	0.0%	0.9%	
Pedestrians	0	0	0	0	0	2	1	0	0	0	0	0	0	0	0	0	0	0	0	0	2	0	0	0	0	0	2	0	0	
% Pedestrians	0.0%	0.0%	0.0%	0.0%	0.0%	100.0%	100.0%	0.0%	0.0%	0.0%	0.0%	0.0%	0.0%	0.0%	0.0%	0.0%	0.0%	0.0%	0.0%	0.0%	100.0%	0.0%	0.0%	0.0%	0.0%	0.0%	0.0%	100.0%	0.0%	0.0%
Bicycles on Crosswalk	0	0	0	0	0	0	0	0	0	0	0	0	0	0	0	0	0	0	0	0	0	0	0	0	0	0	0	0	0	
% Bicycles on Crosswalk	0.0%	0.0%	0.0%	0.0%	0.0%	0.0%	0.0%	0.0%	0.0%	0.0%	0.0%	0.0%	0.0%	0.0%	0.0%	0.0%	0.0%	0.0%	0.0%	0.0%	0.0%	0.0%	0.0%	0.0%	0.0%	0.0%	0.0%	0.0%	0.0%	

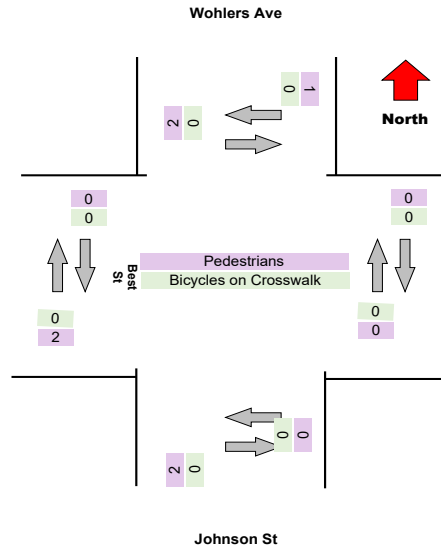
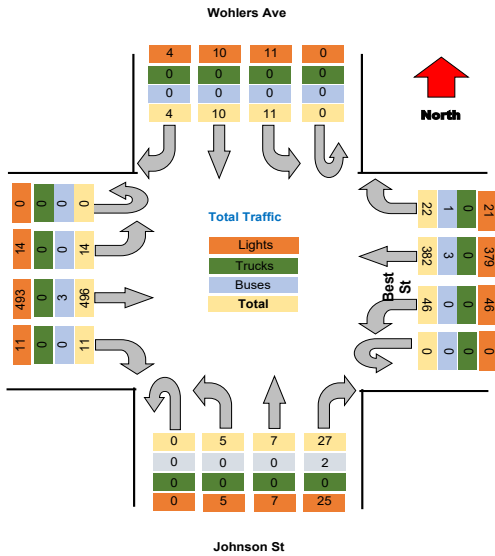

Project : VBH Malta NY
 Site : Site 4
 Location : 42.948550, -73.790036
 Survey Date : 2021-04-28, Wednesday

Turning Movement Data Plot

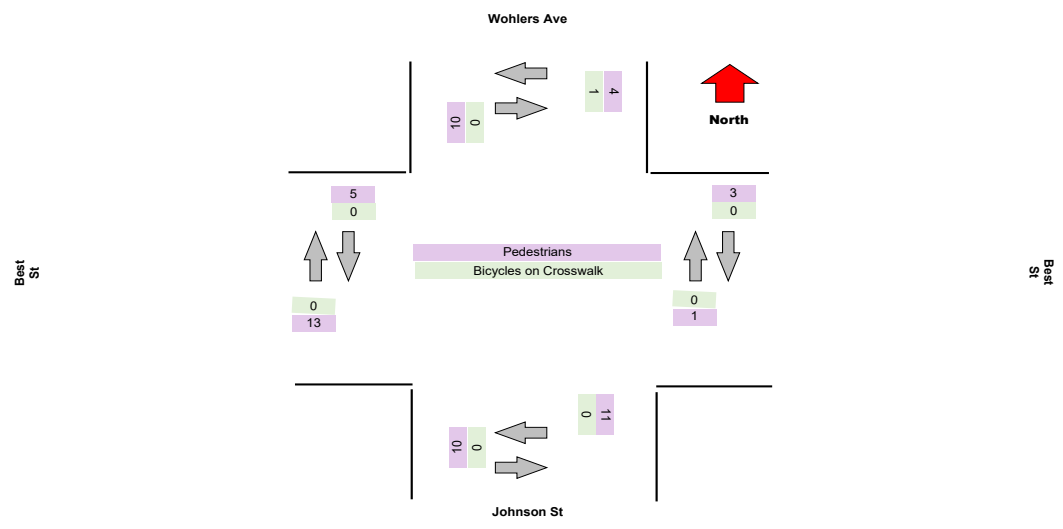
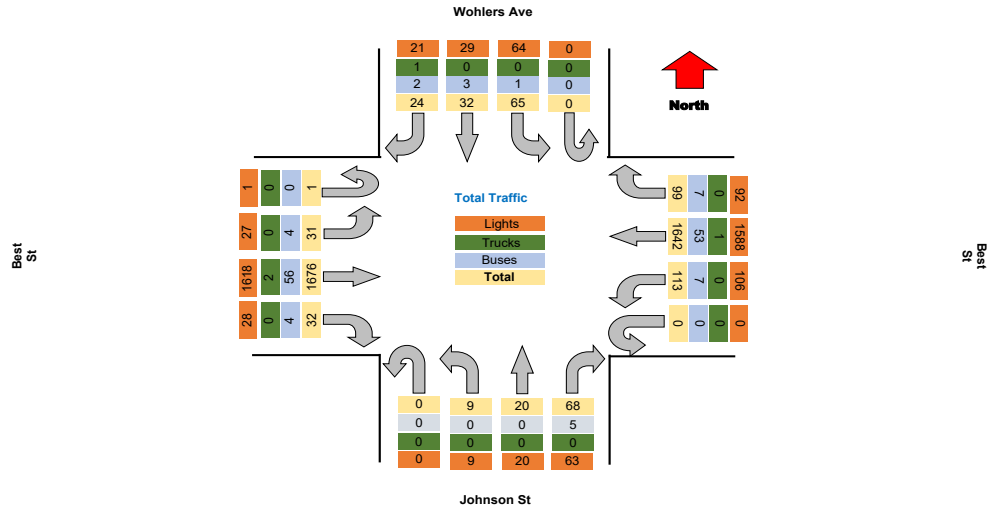

Project : VBH Malta NY
Site : Site 4
Location : 42.948550, -73.790036

TSTData.com

Survey Date : 2021-04-28, Wednesday

Turning Movement Peak Hour Data (AM)

7:30:00 AM

Leg Direction	Wohlers Ave					Best St					Johnson St					Best St					Total								
	Right	Thru	Left	U-Turn	App Total	Peds CW	Peds CCW	Right	Thru	Left	U-Turn	App Total	Peds CW	Peds CCW	Right	Thru	Left	U-Turn	App Total	Peds CW		Peds CCW							
7:30:00 AM	1	0	7	0	8	0	0	6	101	4	0	111	0	0	5	1	0	0	6	0	0	108	0	0	109	1	0	234	
7:45:00 AM	2	5	5	0	12	0	0	5	148	15	0	168	0	0	11	3	1	0	15	1	1	2	121	0	0	123	0	0	318
8:00:00 AM	0	1	1	0	2	0	0	6	145	12	0	163	0	0	7	0	0	0	7	0	0	3	120	1	0	124	0	0	296
8:15:00 AM	1	2	3	0	6	0	0	4	108	7	0	129	0	0	0	0	1	0	1	1	2	0	74	2	0	76	0	0	293
Grand Total	4	8	16	0	28	0	0	21	502	38	0	562	0	0	23	4	2	0	29	2	3	6	423	3	0	432	1	0	1051
% Approach	14.3%	28.6%	57.1%	0.0%	0.0%	0.0%	0.0%	3.7%	89.3%	6.8%	0.0%	0.0%	0.0%	0.0%	79.3%	13.8%	6.9%	0.0%	0.0%	0.0%	0.0%	1.4%	97.9%	0.7%	0.0%	0.0%	0.0%	0.0%	0.0%
% Total	0.4%	0.8%	1.5%	0.0%	2.7%	0.0%	0.0%	2.0%	47.8%	3.6%	0.0%	63.5%	0.0%	0.0%	2.2%	0.4%	0.2%	0.0%	2.8%	0.0%	0.0%	0.6%	40.2%	0.3%	0.0%	41.1%	0.0%	0.0%	0.0%
PHF	0.500	0.400	0.571	0.000	0.583	0.000	0.000	0.875	0.848	0.633	0.000	0.836	0.000	0.000	0.523	0.333	0.500	0.000	0.483	0.000	0.000	0.500	0.874	0.375	0.000	0.871	0.000	0.000	0.826
Lights	4	8	15	0	27	0	0	19	482	34	0	535	0	0	21	4	2	0	27	0	0	5	412	3	0	420	0	0	1009
% Lights	100.0%	100.0%	93.8%	0.0%	96.4%	0.0%	0.0%	90.5%	96.0%	89.5%	0.0%	95.2%	0.0%	0.0%	91.3%	100.0%	100.0%	0.0%	93.1%	0.0%	0.0%	83.3%	97.4%	100.0%	0.0%	97.2%	0.0%	0.0%	96.0%
Trucks	0	0	0	0	0	0	0	0	1	0	0	1	0	0	0	0	0	0	0	0	0	0	1	0	0	1	0	0	2
% Trucks	0.0%	0.0%	0.0%	0.0%	0.0%	0.0%	0.0%	0.0%	0.2%	0.0%	0.0%	0.2%	0.0%	0.0%	0.0%	0.0%	0.0%	0.0%	0.0%	0.0%	0.0%	0.0%	0.2%	0.0%	0.0%	0.2%	0.0%	0.0%	0.2%
Buses	0	0	1	0	1	0	0	2	19	4	0	25	0	0	2	0	0	0	2	0	0	1	10	0	0	11	0	0	39
% Buses	0.0%	0.0%	6.3%	0.0%	0.0%	0.0%	0.0%	9.5%	3.8%	10.5%	0.0%	0.0%	0.0%	0.0%	8.7%	0.0%	0.0%	0.0%	0.0%	0.0%	0.0%	16.7%	2.4%	0.0%	0.0%	0.0%	0.0%	0.0%	3.7%
Pedestrians	0	0	0	0	0	0	0	0	0	0	0	0	0	0	0	0	0	0	0	2	3	0	0	0	0	0	1	0	0
% Pedestrians	0.0%	0.0%	0.0%	0.0%	0.0%	0.0%	100.0%	0.0%	0.0%	0.0%	0.0%	0.0%	0.0%	0.0%	0.0%	0.0%	0.0%	0.0%	0.0%	0.0%	100.0%	100.0%	0.0%	0.0%	0.0%	0.0%	100.0%	0.0%	0.0%
Bicycles on Crosswalk	0	0	0	0	0	0	0	0	0	0	0	0	0	0	0	0	0	0	0	0	0	0	0	0	0	0	0	0	0
% Bicycles on Crosswalk	0.0%	0.0%	0.0%	0.0%	0.0%	0.0%	0.0%	0.0%	0.0%	0.0%	0.0%	0.0%	0.0%	0.0%	0.0%	0.0%	0.0%	0.0%	0.0%	0.0%	0.0%	0.0%	0.0%	0.0%	0.0%	0.0%	0.0%	0.0%	0.0%

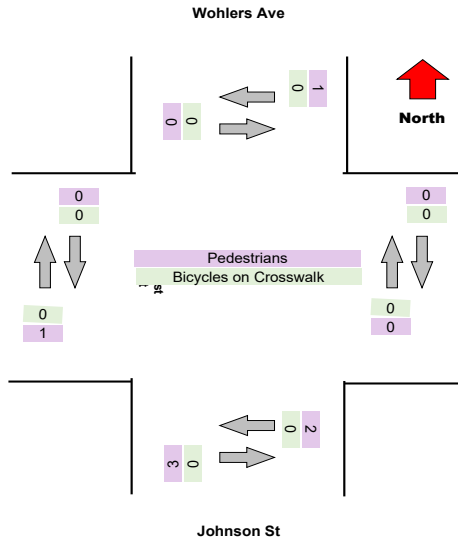
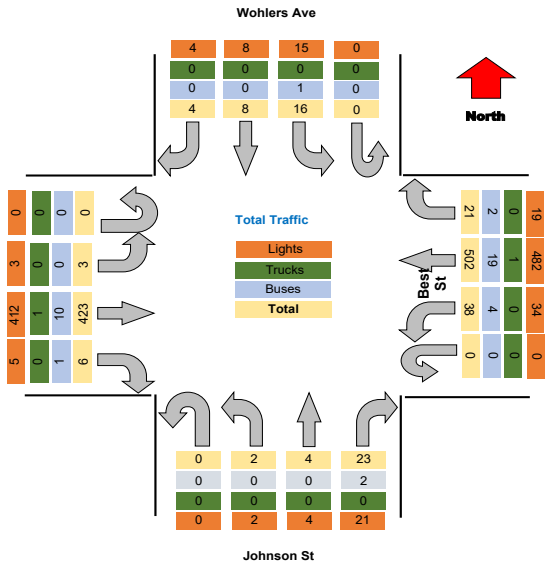

Turning Movement Peak Hour Data (PM)

4:15:00 PM

Leg Direction	Wohlers Ave					Best St					Johnson St					Best St					Total								
	Southbound					Westbound					Northbound					Eastbound													
Start Time	Right	Thru	Left	U-Turn	App Total	Peds CW	Peds CCW	Right	Thru	Left	U-Turn	App Total	Peds CW	Peds CCW	Right	Thru	Left	U-Turn	App Total	Peds CW	Peds CCW	Right	Thru	Left	U-Turn	App Total	Peds CW	Peds CCW	
4:15:00 PM	4	7	3	0	14	2	2	10	116	13	0	139	3	1	3	3	0	0	6	0	0	1	142	2	0	145	0	0	304
4:30:00 PM	3	4	6	0	13	0	0	7	81	9	0	97	0	0	14	4	1	0	19	2	0	3	168	5	0	176	4	2	305
4:45:00 PM	2	4	0	0	6	0	0	7	102	8	0	117	0	0	8	2	2	0	12	0	4	5	117	3	0	125	0	0	260
5:00:00 PM	1	4	7	0	9	1	0	8	95	4	0	107	0	0	3	1	0	0	4	0	1	2	136	3	1	142	0	0	282
Grand Total	10	16	16	0	42	3	2	32	394	34	0	460	3	1	28	10	3	0	41	2	5	11	563	13	1	586	4	2	1131
% Approach	23.8%	38.1%	38.1%	0.0%	0.0%	0.0%	0.0%	7.0%	85.7%	7.4%	0.0%	0.0%	0.0%	0.0%	68.3%	24.4%	7.3%	0.0%	0.0%	0.0%	0.0%	1.9%	95.7%	2.2%	0.2%	0.0%	0.0%	0.0%	
% Total	0.9%	1.4%	1.4%	0.0%	3.7%	0.0%	0.0%	2.8%	34.8%	3.0%	0.0%	40.7%	0.0%	0.0%	2.5%	0.9%	0.3%	0.0%	3.6%	0.0%	0.0%	1.0%	49.8%	1.1%	0.1%	52.0%	0.0%	0.0%	
PHF	0.625	0.571	0.571	0.000	0.750	0.000	0.000	0.800	0.849	0.654	0.000	0.827	0.000	0.000	0.500	0.625	0.375	0.000	0.539	0.000	0.000	0.550	0.838	0.650	0.250	0.835	0.000	0.000	0.927
Lights	9	13	16	0	38	0	0	30	384	33	0	447	0	0	26	10	3	0	39	0	0	10	546	12	1	569	0	0	1093
% Lights	80.0%	81.3%	100.0%	0.0%	90.5%	0.0%	0.0%	83.8%	97.5%	97.1%	0.0%	97.2%	0.0%	0.0%	92.9%	100.0%	100.0%	0.0%	95.1%	0.0%	0.0%	90.9%	97.0%	92.3%	100.0%	96.8%	0.0%	0.0%	96.6%
Trucks	0	0	0	0	0	0	0	0	0	0	0	0	0	0	0	0	0	0	0	0	0	0	0	0	0	0	0	0	0
% Trucks	0.0%	0.0%	0.0%	0.0%	0.0%	0.0%	0.0%	0.0%	0.0%	0.0%	0.0%	0.0%	0.0%	0.0%	0.0%	0.0%	0.0%	0.0%	0.0%	0.0%	0.0%	0.0%	0.0%	0.0%	0.0%	0.0%	0.0%	0.0%	0.0%
Buses	1	3	0	0	4	0	0	2	10	1	0	13	0	0	2	0	0	0	2	0	0	1	17	1	0	19	0	0	38
% Buses	10.0%	18.8%	0.0%	0.0%	0.0%	0.0%	0.0%	6.3%	2.5%	2.9%	0.0%	0.0%	0.0%	0.0%	7.1%	0.0%	0.0%	0.0%	0.0%	0.0%	0.0%	9.1%	3.0%	7.7%	0.0%	0.0%	0.0%	3.4%	
Pedestrians	0	0	0	0	0	3	2	0	0	0	0	0	3	1	0	0	0	0	0	2	5	0	0	0	0	0	4	2	10
% Pedestrians	0.0%	0.0%	0.0%	0.0%	0.0%	100.0%	100.0%	0.0%	0.0%	0.0%	0.0%	0.0%	100.0%	100.0%	0.0%	0.0%	0.0%	0.0%	0.0%	0.0%	100.0%	100.0%	0.0%	0.0%	0.0%	0.0%	0.0%	100.0%	100.0%
Bicycles on Crosswalk	0	0	0	0	0	0	0	0	0	0	0	0	0	0	0	0	0	0	0	0	0	0	0	0	0	0	0	0	0
% Bicycles on Crosswalk	0.0%	0.0%	0.0%	0.0%	0.0%	0.0%	0.0%	0.0%	0.0%	0.0%	0.0%	0.0%	0.0%	0.0%	0.0%	0.0%	0.0%	0.0%	0.0%	0.0%	0.0%	0.0%	0.0%	0.0%	0.0%	0.0%	0.0%	0.0%	0.0%

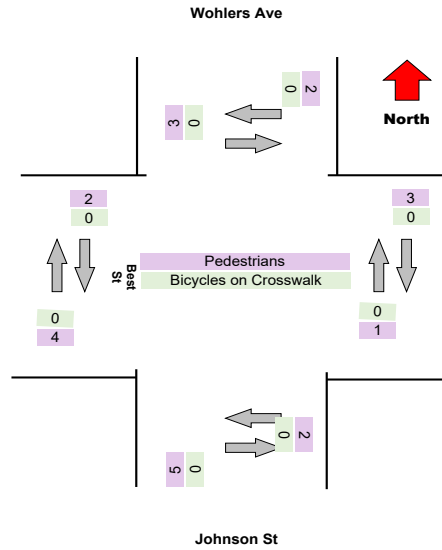
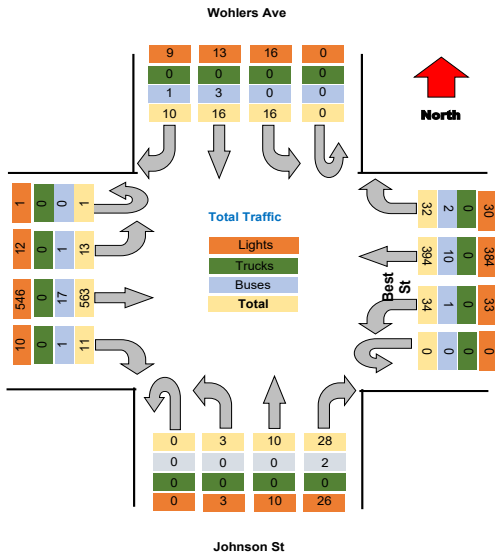

Project : VBH Malta NY
 Site : Site 4
 Location : 42.948550, -73.790036
 Survey Date : 2021-04-28, Wednesday

Turning Movement Data Plot

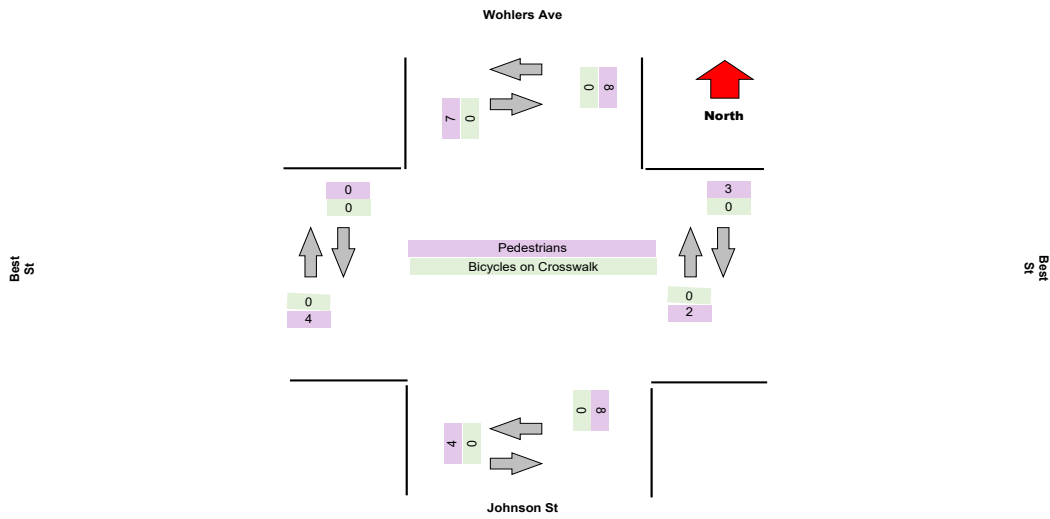
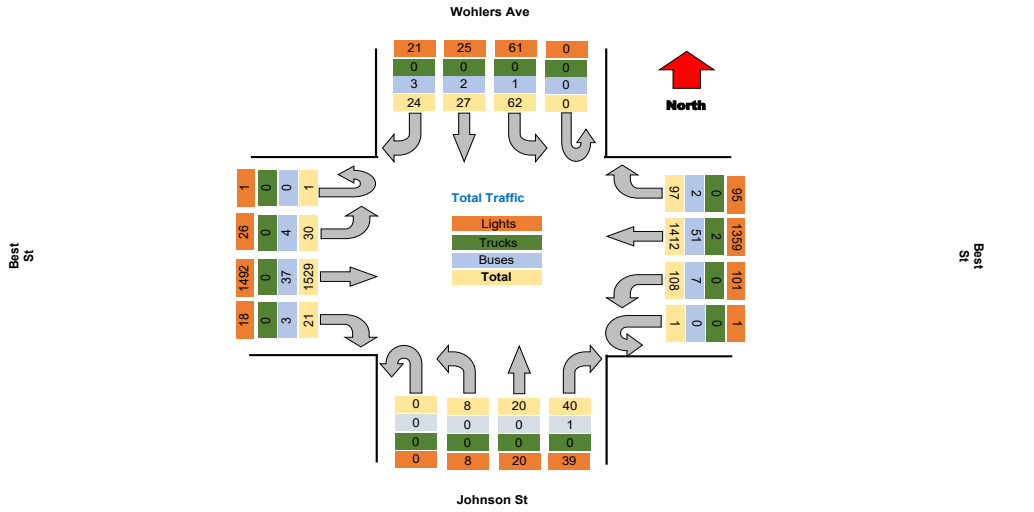

Project : VBH Malta NY
Site : Site 4
Location : 42.948550, -73.790036

TSTData.com

Survey Date : 2021-04-28, Wednesday

Turning Movement Peak Hour Data (AM)

6:30:00 AM

Leg Direction	Wohlers Ave							Best St							Johnson St							Best St							Total		
	Southbound				App Total			Westbound				App Total			Northbound				App Total			Eastbound									
Start Time	Right	Thru	Left	U-Turn	Peds CW	Peds CCW	Right	Thru	Left	U-Turn	Peds CW	Peds CCW	Right	Thru	Left	U-Turn	Peds CW	Peds CCW	Right	Thru	Left	U-Turn	Peds CW	Peds CCW	Right	Thru	Left	U-Turn	Peds CW	Peds CCW	
6:30:00 AM	2	0	5	0	7	0	1	96	3	0	100	0	0	2	0	0	2	0	0	0	40	0	0	40	0	0	0	0	0	0	149
6:45:00 AM	1	0	1	0	2	0	1	100	5	0	106	0	0	1	1	1	0	3	0	0	1	44	0	0	45	0	0	0	0	156	
7:00:00 AM	1	1	2	0	4	0	2	89	2	0	94	0	0	0	0	1	0	1	4	0	0	44	2	0	45	0	0	0	0	124	
7:15:00 AM	2	0	3	0	5	0	4	91	2	0	97	0	0	0	0	1	0	1	1	1	2	66	1	0	69	0	0	0	0	172	
Grand Total	6	1	11	0	19	0	8	356	12	0	377	0	0	3	1	3	0	7	3	1	3	153	3	0	159	3	0	0	0	691	
% Approach	33.3%	5.6%	61.1%	0.0%	0.0%	0.0%	2.1%	94.4%	3.2%	0.0%	0.0%	0.0%	42.9%	14.3%	42.9%	0.0%	0.0%	0.0%	1.5%	97.0%	1.5%	0.0%	0.0%	0.0%	0.0%	0.0%	0.0%	0.0%	0.0%	0.0%	
% Total	1.0%	0.2%	1.8%	0.0%	3.0%	0.0%	1.3%	59.2%	2.0%	0.0%	62.7%	0.0%	0.0%	0.5%	0.2%	0.5%	0.0%	1.2%	0.0%	0.0%	0.5%	32.1%	0.5%	0.0%	33.1%	0.0%	0.0%	0.0%	0.0%		
PHF	0.750	0.250	0.550	0.000	0.643	0.000	0.500	0.890	0.600	0.000	0.889	0.000	0.000	0.375	0.250	0.750	0.000	0.583	0.000	0.000	0.375	0.731	0.375	0.000	0.721	0.000	0.000	0.000	0.874		
Lights	4	1	11	0	16	0	8	338	10	0	356	0	0	3	1	3	0	7	0	0	1	182	1	0	184	0	0	0	563		
% Lights	66.7%	100.0%	100.0%	0.0%	88.9%	0.0%	100.0%	94.9%	83.3%	0.0%	94.4%	0.0%	0.0%	100.0%	100.0%	100.0%	0.0%	100.0%	0.0%	0.0%	33.3%	94.3%	33.3%	0.0%	92.5%	0.0%	0.0%	0.0%	93.7%		
Trucks	0	0	0	0	0	0	0	1	0	0	1	0	0	0	0	0	0	0	0	0	0	0	0	0	0	0	0	0	0	1	
% Trucks	0.0%	0.0%	0.0%	0.0%	0.0%	0.0%	0.0%	0.3%	0.0%	0.0%	0.3%	0.0%	0.0%	0.0%	0.0%	0.0%	0.0%	0.0%	0.0%	0.0%	0.0%	0.0%	0.0%	0.0%	0.0%	0.0%	0.0%	0.0%	0.2%		
Buses	2	0	0	0	2	0	0	17	2	0	19	0	0	0	0	0	0	0	0	0	2	11	2	0	15	0	0	0	0	36	
% Buses	33.3%	0.0%	0.0%	0.0%	0.0%	0.0%	0.0%	4.8%	16.7%	0.0%	5.0%	0.0%	0.0%	0.0%	0.0%	0.0%	0.0%	0.0%	0.0%	0.0%	5.7%	66.7%	5.7%	0.0%	66.7%	0.0%	0.0%	0.0%	6.0%		
Pedestrians	0	0	0	0	0	1	0	0	0	0	0	0	0	0	0	0	5	1	0	0	0	0	0	0	0	0	0	0	0	0	
% Pedestrians	0.0%	0.0%	0.0%	0.0%	0.0%	100.0%	0.0%	0.0%	0.0%	0.0%	0.0%	0.0%	0.0%	0.0%	0.0%	0.0%	0.0%	0.0%	0.0%	0.0%	0.0%	0.0%	0.0%	0.0%	0.0%	0.0%	0.0%	0.0%	0.0%	0.0%	
Bicycles on Crosswalk	0	0	0	0	0	0	0	0	0	0	0	0	0	0	0	0	0	0	0	0	0	0	0	0	0	0	0	0	0	0	
% Bicycles on Crosswalk	0.0%	0.0%	0.0%	0.0%	0.0%	0.0%	0.0%	0.0%	0.0%	0.0%	0.0%	0.0%	0.0%	0.0%	0.0%	0.0%	0.0%	0.0%	0.0%	0.0%	0.0%	0.0%	0.0%	0.0%	0.0%	0.0%	0.0%	0.0%	0.0%	0.0%	

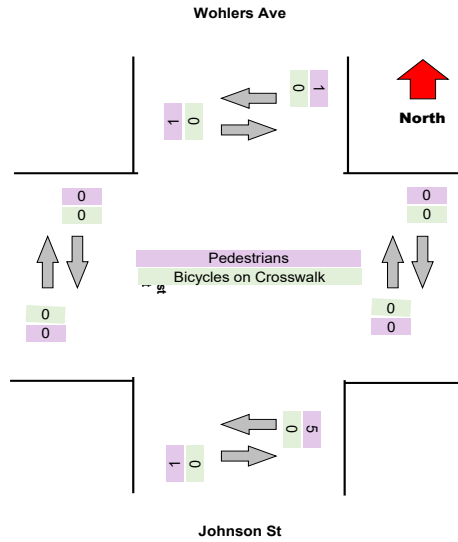
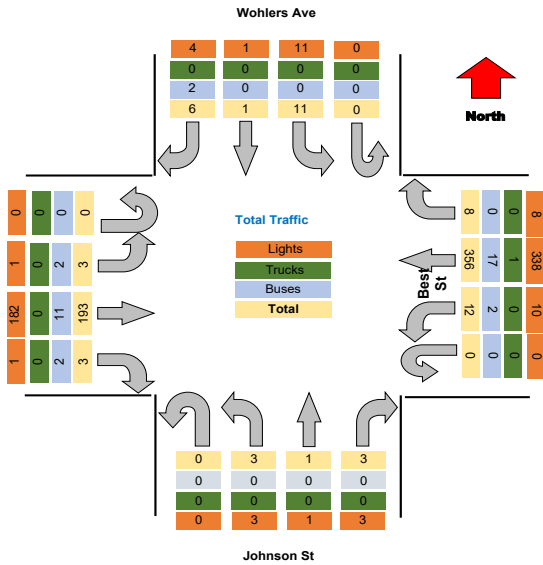

Turning Movement Peak Hour Data (PM)

4:15:00 PM

Leg Direction	Wohlers Ave						Best St						Johnson St						Best St						Total				
	Southbound			Westbound			Northbound			Eastbound			Northbound			Eastbound													
	Right	Thru	Left	U-Turn	App Total	Peds CW	Peds CCW	Right	Thru	Left	U-Turn	App Total	Peds CW	Peds CCW	Right	Thru	Left	U-Turn	App Total	Peds CW	Peds CCW								
4:15:00 PM	3	3	6	0	12	2	1	14	93	15	0	122	3	1	3	0	2	0	5	1	1	3	132	2	0	137	0	0	276
4:30:00 PM	3	4	12	0	19	0	0	10	68	10	0	88	0	0	12	3	2	0	17	0	0	1	153	3	0	157	0	0	281
4:45:00 PM	1	4	5	0	10	0	2	11	87	13	0	111	0	0	2	4	0	0	6	0	0	2	126	5	0	133	0	0	260
5:00:00 PM	1	3	0	0	4	0	0	6	62	6	0	74	0	0	1	3	0	0	4	1	0	5	132	5	0	142	0	0	244
Grand Total	9	14	23	0	45	2	3	41	330	44	0	415	3	1	19	10	4	0	32	2	1	11	543	15	0	558	3	0	1061
% Approach	17.8%	31.1%	51.1%	0.0%	0.0%	0.0%	0.0%	9.0%	79.5%	10.6%	0.0%	0.0%	0.0%	0.0%	56.3%	31.3%	12.5%	0.0%	0.0%	0.0%	0.0%	1.9%	95.4%	2.6%	0.0%	0.0%	0.0%	0.0%	0.0%
% Total	0.8%	1.3%	2.2%	0.0%	4.2%	0.0%	0.0%	3.9%	31.1%	4.1%	0.0%	38.1%	0.0%	0.0%	1.7%	0.9%	0.4%	0.0%	3.0%	0.0%	0.0%	1.0%	51.2%	1.4%	0.0%	33.6%	0.0%	0.0%	0.0%
PHF	0.667	0.875	0.479	0.000	0.592	0.000	0.000	0.732	0.887	0.733	0.000	0.850	0.000	0.000	0.375	0.625	0.500	0.000	0.471	0.000	0.000	0.550	0.887	0.750	0.000	0.906	0.000	0.000	0.944
Lights	7	12	23	0	42	0	0	40	318	42	0	400	0	0	17	10	4	0	31	0	0	10	533	14	0	557	0	0	1030
% Lights	87.5%	85.7%	100.0%	0.0%	93.3%	0.0%	0.0%	87.6%	96.4%	95.5%	0.0%	96.4%	0.0%	0.0%	84.4%	100.0%	100.0%	0.0%	96.9%	0.0%	0.0%	90.9%	98.2%	93.3%	0.0%	97.9%	0.0%	0.0%	97.1%
Trucks	0	0	0	0	0	0	0	0	0	0	0	0	0	0	0	0	0	0	0	0	0	0	0	0	0	0	0	0	0
% Trucks	0.0%	0.0%	0.0%	0.0%	0.0%	0.0%	0.0%	0.0%	0.0%	0.0%	0.0%	0.0%	0.0%	0.0%	0.0%	0.0%	0.0%	0.0%	0.0%	0.0%	0.0%	0.0%	0.0%	0.0%	0.0%	0.0%	0.0%	0.0%	0.0%
Buses	1	2	0	0	3	0	0	1	12	2	0	15	0	0	1	0	0	0	1	0	0	1	10	1	0	12	0	0	31
% Buses	12.5%	14.3%	0.0%	0.0%	0.0%	0.0%	0.0%	2.4%	3.6%	4.5%	0.0%	0.0%	0.0%	0.0%	5.6%	0.0%	0.0%	0.0%	0.0%	0.0%	0.0%	9.1%	1.8%	6.7%	0.0%	0.0%	0.0%	2.9%	
Pedestrians	0	0	0	0	0	2	4	0	0	0	0	3	1	0	0	0	0	0	0	2	1	0	0	0	0	0	0	0	
% Pedestrians	0.0%	0.0%	0.0%	0.0%	0.0%	100.0%	100.0%	0.0%	0.0%	0.0%	0.0%	0.0%	100.0%	100.0%	0.0%	0.0%	0.0%	0.0%	0.0%	0.0%	100.0%	100.0%	0.0%	0.0%	0.0%	0.0%	0.0%	0.0%	0.0%
Bicycles on Crosswalk	0	0	0	0	0	0	0	0	0	0	0	0	0	0	0	0	0	0	0	0	0	0	0	0	0	0	0	0	
% Bicycles on Crosswalk	0.0%	0.0%	0.0%	0.0%	0.0%	0.0%	0.0%	0.0%	0.0%	0.0%	0.0%	0.0%	0.0%	0.0%	0.0%	0.0%	0.0%	0.0%	0.0%	0.0%	0.0%	0.0%	0.0%	0.0%	0.0%	0.0%	0.0%	0.0%	0.0%

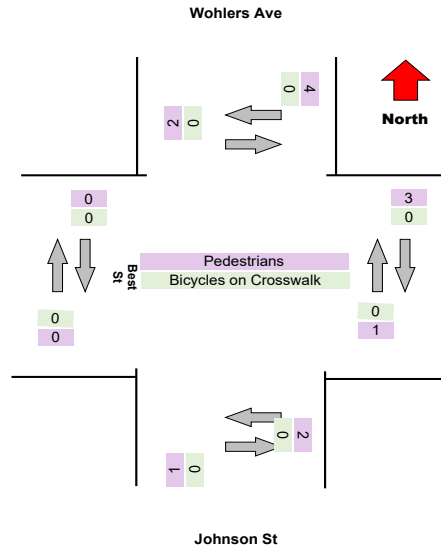
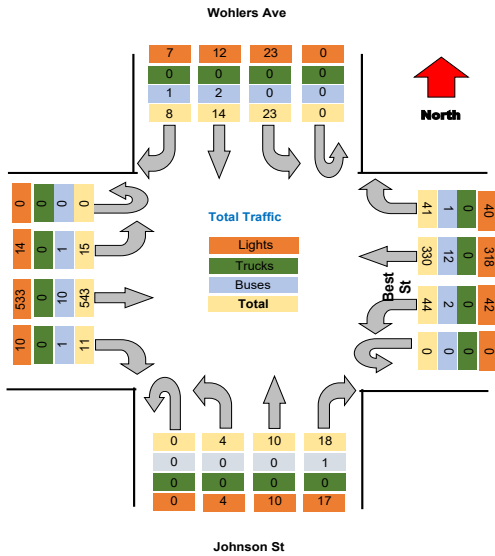

Turning Movement Data Plot

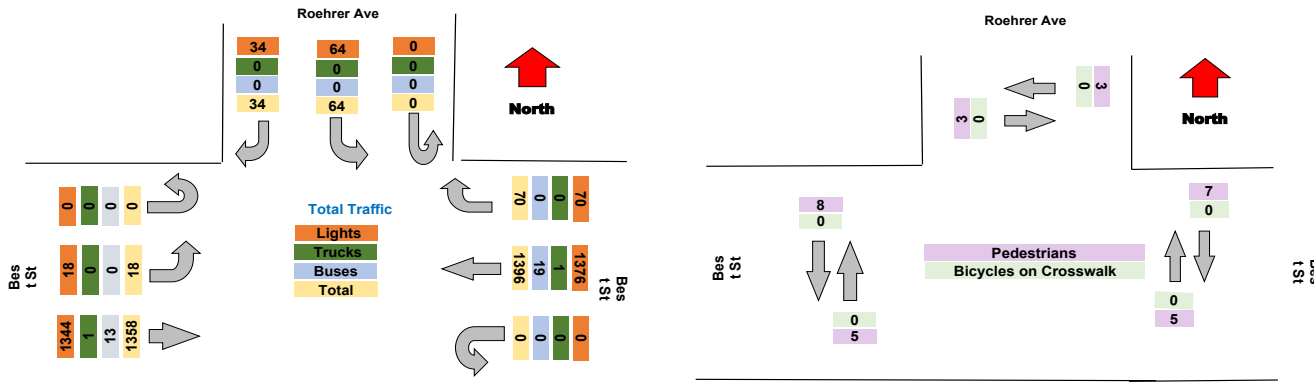

Turning Movement Peak Hour Data (AM)

7:30:00 AM

Leg Direction	Roehrer Ave Southbound						Best St Westbound						Best St Eastbound						Total
	Right	Left	U-Turn	App Total	Peds CW	Peds CCW	Right	Thru	U-Turn	App Total	Peds CW	Peds CCW	Thru	Left	U-Turn	App Total	Peds CW	Peds CCW	
7:30:00 AM	2	3	0	5	0	0	2	88	0	90	0	0	75	0	0	75	0	0	170
7:45:00 AM	1	7	0	8	0	0	9	98	0	107	1	0	59	1	0	61	0	1	176
8:00:00 AM	1	4	0	5	0	1	4	83	0	88	0	0	56	0	0	56	0	3	149
8:15:00 AM	0	3	0	3	0	0	1	102	0	103	0	0	52	0	0	52	0	0	158
Grand Total	4	17	0	21	0	1	16	371	0	388	1	0	242	1	0	244	0	4	653
% Approach	19.0%	81.0%	0.0%	0.0%	0.0%	0.0%	4.1%	95.6%	0.0%	0.0%	0.0%	0.0%	99.2%	0.4%	0.0%	0.0%	0.0%	0.0%	
% Total	0.6%	2.6%	0.0%	3.2%	0.0%	0.0%	2.5%	56.8%	0.0%	59.4%	0.0%	0.0%	37.1%	0.2%	0.0%	37.4%	0.0%	0.0%	
PHF	0.500	0.607	0.000	0.656	0.000	0.000	0.444	0.909	0.000	0.907	0.000	0.000	0.807	0.250	0.000	0.813	0.000	0.000	0.928
Lights	4	17	0	21	0	0	16	362	0	378	0	0	236	1	0	237	0	0	636
% Lights	#####	100.0%	0.0%	100.0%	0.0%	0.0%	100.0%	97.6%	0.0%	97.4%	0.0%	0.0%	97.5%	100.0%	0.0%	97.1%	0.0%	0.0%	97.4%
Trucks	0	0	0	0	0	0	0	0	0	0	0	0	1	0	0	1	0	0	1
% Trucks	0.0%	0.0%	0.0%	0.0%	0.0%	0.0%	0.0%	0.0%	0.0%	0.0%	0.0%	0.0%	0.4%	0.0%	0.0%	0.4%	0.0%	0.0%	0.2%
Buses	0	0	0	0	0	0	0	9	0	9	0	0	5	0	0	5	0	0	14
% Buses	0.0%	0.0%	0.0%	0.0%	0.0%	0.0%	0.0%	2.4%	0.0%	0.0%	0.0%	0.0%	2.1%	0.0%	0.0%	0.0%	0.0%	0.0%	2.1%
Pedestrians	0	0	0	0	0	1	0	0	0	1	0	0	0	0	0	0	0	4	0
% Pedestrians	0.0%	0.0%	0.0%	0.0%	0.0%	100.0%	0.0%	0.0%	0.0%	0.0%	100.0%	0.0%	0.0%	0.0%	0.0%	0.0%	0.0%	100.0%	0.0%
Bicycles on Crosswalk	0	0	0	0	0	0	0	0	0	0	0	0	0	0	0	0	0	0	0
% Bicycles on Crosswalk	0.0%	0.0%	0.0%	0.0%	0.0%	0.0%	0.0%	0.0%	0.0%	0.0%	0.0%	0.0%	0.0%	0.0%	0.0%	0.0%	0.0%	0.0%	0.0%

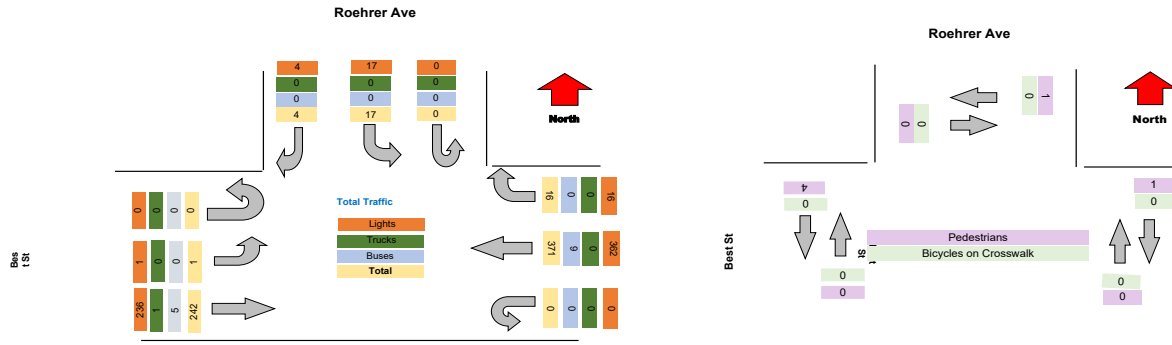

Turning Movement Peak Hour Data (PM)
 4:15:00 PM

Leg Direction	Roehrer Ave Southbound						Best St Westbound						Best St Eastbound						Total
	Right	Left	U-Turn	App Total	Peds CW	Peds CCW	Right	Thru	U-Turn	App Total	Peds CW	Peds CCW	Thru	Left	U-Turn	App Total	Peds CW	Peds CCW	
4:15:00 PM	3	5	0	8	0	0	5	87	0	92	1	1	128	0	0	128	0	0	228
4:30:00 PM	3	2	0	5	1	0	11	87	0	98	0	0	125	1	0	126	0	0	229
4:45:00 PM	6	5	0	11	0	0	6	88	0	94	1	1	108	3	0	111	1	0	216
5:00:00 PM	5	3	0	8	0	1	4	99	0	103	0	0	137	5	0	142	0	0	253
Grand Total	17	15	0	32	1	1	26	361	0	387	2	2	498	9	0	507	1	0	926
% Approach	53.1%	46.9%	0.0%	0.0%	0.0%	0.0%	6.7%	93.3%	0.0%	0.0%	0.0%	0.0%	98.2%	1.8%	0.0%	0.0%	0.0%	0.0%	
% Total	1.8%	1.6%	0.0%	3.5%	0.0%	0.0%	2.8%	39.0%	0.0%	41.8%	0.0%	0.0%	53.8%	1.0%	0.0%	54.8%	0.0%	0.0%	
PHF	0.708	0.750	0.000	0.727	0.000	0.000	0.591	0.912	0.000	0.939	0.000	0.000	0.909	0.450	0.000	0.893	0.000	0.000	0.915
Lights	17	15	0	32	0	0	26	358	0	384	0	0	495	9	0	504	0	0	920
% Lights	###	100.0%	0.0%	100.0%	0.0%	0.0%	100.0%	99.2%	0.0%	99.2%	0.0%	0.0%	99.4%	100.0%	0.0%	99.4%	0.0%	0.0%	99.4%
Trucks	0	0	0	0	0	0	0	0	0	0	0	0	0	0	0	0	0	0	0
% Trucks	0.0%	0.0%	0.0%	0.0%	0.0%	0.0%	0.0%	0.0%	0.0%	0.0%	0.0%	0.0%	0.0%	0.0%	0.0%	0.0%	0.0%	0.0%	0.0%
Buses	0	0	0	0	0	0	0	3	0	3	0	0	3	0	0	3	0	0	6
% Buses	0.0%	0.0%	0.0%	0.0%	0.0%	0.0%	0.0%	0.8%	0.0%	0.0%	0.0%	0.0%	0.6%	0.0%	0.0%	0.0%	0.0%	0.0%	0.6%
Pedestrians	0	0	0	0	1	1	0	0	0	0	2	2	0	0	0	0	1	0	0
% Pedestrians	0.0%	0.0%	0.0%	0.0%	100.0%	100.0%	0.0%	0.0%	0.0%	0.0%	100.0%	100.0%	0.0%	0.0%	0.0%	0.0%	100.0%	0.0%	0.0%
Bicycles on Crosswalk	0	0	0	0	0	0	0	0	0	0	0	0	0	0	0	0	0	0	0
% Bicycles on Crosswalk	0.0%	0.0%	0.0%	0.0%	0.0%	0.0%	0.0%	0.0%	0.0%	0.0%	0.0%	0.0%	0.0%	0.0%	0.0%	0.0%	0.0%	0.0%	0.0%

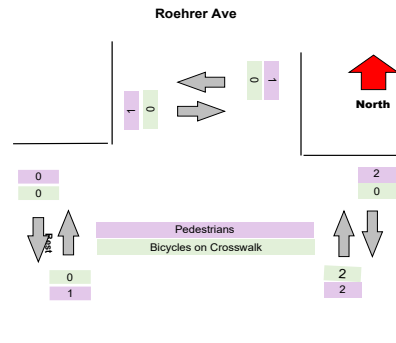
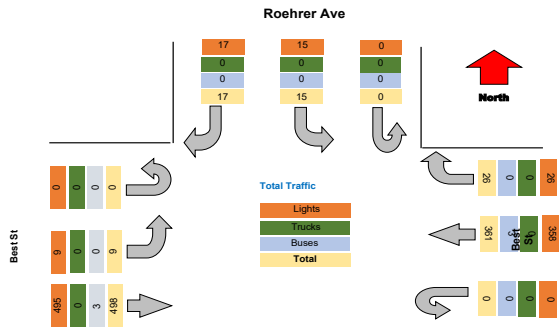

Intersection: Elm St Pine St
 Location: Kennett Square, PA
 Site: 01
 Survey Date: Wednesday, 04-28-2021
 GPS: 42.948550, -72.790034



Project	LaBella
Project Code	LaBella
Site Name	U
Legs and Movements	All Processed Legs & Movements
Bin Size	15 minutes
Survey Date	2021-11-03, Wednesday
Location	U
Latitude and Longitude	42.903791, -78.849141

	Start	End	PHF
Forced Peak AM	2021/11/03 07:30:00	2021/11/03 08:30:00	0.8357
Forced Peak PM	2021/11/03 16:30:00	2021/11/03 17:30:00	0.9099
AM Peak	2021/11/03 07:30:00	2021/11/03 08:30:00	0.8357
PM Peak	2021/11/03 16:15:00	2021/11/03 17:15:00	0.9461

Turning Movement Data

Leg Direction	Roehrer Ave Southbound						Best St Westbound						Best St Eastbound						Total
	Right	Left	U-Turn	App Total	Peds CW	Peds CCW	Right	Thru	U-Turn	App Total	Peds CW	Peds CCW	Thru	Left	U-Turn	App Total	Peds CW	Peds CCW	
Start Time																			
6:30:00 AM	0	1	0	1	0	0	1	95	0	96	0	0	25	0	0	25	0	0	122
6:45:00 AM	2	2	1	5	1	2	3	106	0	111	0	1	39	0	0	40	2	3	156
Hourly Total	2	3	1	6	1	2	4	201	0	207	0	1	64	0	0	65	2	3	278
7:00:00 AM	0	2	0	2	0	1	4	69	0	74	0	0	65	2	0	67	0	0	143
7:15:00 AM	2	4	0	6	1	2	1	112	0	115	0	0	64	0	0	64	0	0	185
7:30:00 AM	3	3	0	6	0	2	2	96	0	100	0	0	105	0	0	105	0	0	211
7:45:00 AM	0	5	0	5	2	1	7	151	1	160	0	0	116	2	0	118	0	1	283
Hourly Total	5	14	0	19	3	6	14	428	1	449	0	0	350	4	0	354	0	1	822
8:00:00 AM	1	2	0	3	0	1	3	138	0	142	0	0	116	2	0	118	0	3	263
8:15:00 AM	2	3	0	5	1	0	5	107	0	112	0	0	72	0	0	72	0	0	189
Hourly Total	3	5	0	8	1	1	8	245	0	254	0	0	188	2	0	190	0	3	452
4:00:00 PM	4	3	0	7	4	1	7	93	0	100	0	0	164	2	0	166	2	0	273
4:15:00 PM	4	8	0	12	1	1	3	110	0	113	0	0	139	4	0	143	0	0	268
4:30:00 PM	3	4	0	7	1	1	5	87	0	92	1	1	166	4	0	170	0	0	269
4:45:00 PM	4	4	0	8	0	0	3	97	0	100	0	1	123	3	0	126	0	0	234
Hourly Total	15	19	0	34	6	3	18	387	0	405	1	2	592	13	0	605	2	0	1044
5:00:00 PM	1	5	0	6	1	0	2	101	0	103	0	1	138	0	0	138	0	0	247
5:15:00 PM	3	4	0	7	0	0	2	88	0	90	0	0	131	1	0	132	0	0	229
5:30:00 PM	1	4	0	5	1	0	4	94	0	98	0	1	119	1	0	120	1	2	223
5:45:00 PM	4	2	0	6	0	1	6	81	0	87	0	0	93	0	0	93	0	0	186
Hourly Total	9	15	0	24	2	1	14	364	0	378	0	2	481	2	0	483	1	2	885
Grand Total	34	56	1	91	13	13	58	1625	1	1693	1	5	1675	21	0	1697	5	9	3481
% Approach	37.4%	61.5%	1.1%	0.0%	0.0%	0.0%	3.4%	96.0%	0.1%	0.0%	0.0%	0.0%	98.7%	1.2%	0.0%	0.0%	0.0%	0.0%	0.0%
% Total	1.0%	1.6%	0.0%	2.6%	0.0%	0.0%	1.7%	46.7%	0.0%	48.6%	0.0%	0.0%	48.1%	0.6%	0.0%	48.8%	0.0%	0.0%	0.0%
Lights	31	53	1	85	0	0	58	1568	1	1627	0	0	1612	21	0	1633	0	0	3345
% Lights	91.2%	94.6%	###	93.4%	0.0%	0.0%	100.0%	96.5%	100.0%	96.1%	0.0%	0.0%	96.2%	100.0%	0.0%	96.2%	0.0%	0.0%	96.1%
Trucks	0	0	0	0	0	0	0	2	0	2	0	0	2	0	0	2	0	0	4
% Trucks	0.0%	0.0%	0.0%	0.0%	0.0%	0.0%	0.0%	0.1%	0.0%	0.1%	0.0%	0.0%	0.1%	0.0%	0.0%	0.1%	0.0%	0.0%	0.1%
Buses	3	3	0	6	0	0	0	55	0	55	0	0	61	0	0	61	0	0	122
% Buses	8.8%	5.4%	0.0%	0.0%	0.0%	0.0%	0.0%	3.4%	0.0%	0.0%	0.0%	0.0%	3.6%	0.0%	0.0%	0.0%	0.0%	0.0%	3.5%
Pedestrians	0	0	0	0	13	11	0	0	0	0	1	5	0	0	0	0	5	9	0
% Pedestrians	0.0%	0.0%	0.0%	0.0%	100.0%	84.6%	0.0%	0.0%	0.0%	0.0%	100.0%	100.0%	0.0%	0.0%	0.0%	0.0%	100.0%	100.0%	0.0%
Bicycles on Crosswalk	0	0	0	0	0	2	0	0	0	0	0	0	0	0	0	0	0	0	0
% Bicycles on Crosswalk	0.0%	0.0%	0.0%	0.0%	0.0%	15.4%	0.0%	0.0%	0.0%	0.0%	0.0%	0.0%	0.0%	0.0%	0.0%	0.0%	0.0%	0.0%	0.0%

Turning Movement Data Plot

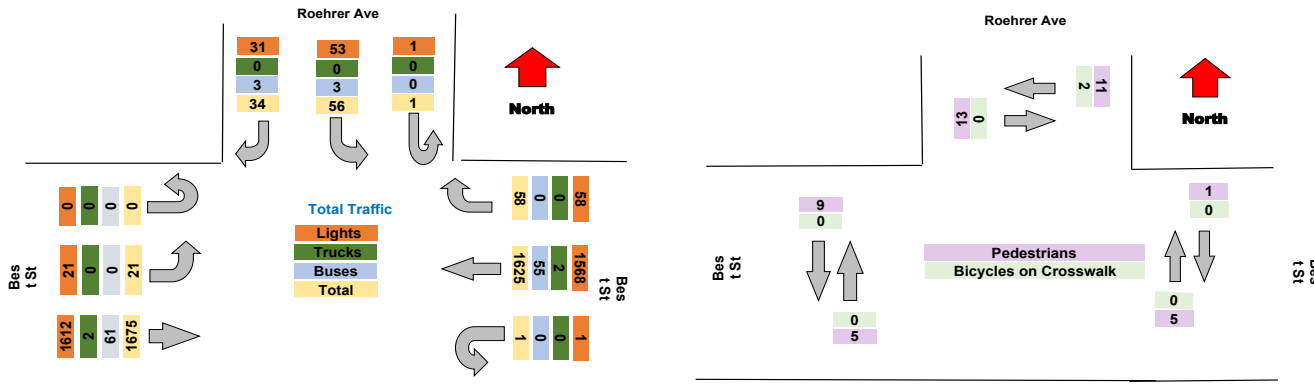

Turning Movement Peak Hour Data (AM)

7:30:00 AM

Leg Direction	Roehrer Ave Southbound						Best St Westbound						Best St Eastbound						Total
	Right	Left	U-Turn	App Total	Peds CW	Peds CCW	Right	Thru	U-Turn	App Total	Peds CW	Peds CCW	Thru	Left	U-Turn	App Total	Peds CW	Peds CCW	
7:30:00 AM	3	3	0	6	0	2	2	96	0	100	0	0	105	0	0	105	0	0	211
7:45:00 AM	0	5	0	5	2	1	7	151	1	160	0	0	116	2	0	118	0	1	283
8:00:00 AM	1	2	0	3	0	1	3	138	0	142	0	0	116	2	0	118	0	3	263
8:15:00 AM	2	3	0	5	1	0	5	107	0	112	0	0	72	0	0	72	0	0	189
Grand Total	6	13	0	19	3	4	17	492	1	514	0	0	409	4	0	413	0	4	946
% Approach	31.6%	68.4%	0.0%	0.0%	0.0%	0.0%	3.3%	95.7%	0.2%	0.0%	0.0%	0.0%	99.0%	1.0%	0.0%	0.0%	0.0%	0.0%	
% Total	0.6%	1.4%	0.0%	2.0%	0.0%	0.0%	1.8%	52.0%	0.1%	54.3%	0.0%	0.0%	43.2%	0.4%	0.0%	43.7%	0.0%	0.0%	
PHF	0.500	0.650	0.000	0.792	0.000	0.000	0.607	0.815	0.250	0.803	0.000	0.000	0.881	0.500	0.000	0.875	0.000	0.000	0.836
Lights	5	13	0	18	0	0	17	473	1	491	0	0	400	4	0	404	0	0	913
% Lights	83.3%	100.0%	0.0%	94.7%	0.0%	0.0%	100.0%	96.1%	100.0%	95.5%	0.0%	0.0%	97.8%	100.0%	0.0%	97.8%	0.0%	0.0%	96.5%
Trucks	0	0	0	0	0	0	0	1	0	1	0	0	0	0	0	0	0	0	1
% Trucks	0.0%	0.0%	0.0%	0.0%	0.0%	0.0%	0.0%	0.2%	0.0%	0.2%	0.0%	0.0%	0.0%	0.0%	0.0%	0.0%	0.0%	0.0%	0.1%
Buses	1	0	0	1	0	0	0	18	0	18	0	0	9	0	0	9	0	0	28
% Buses	16.7%	0.0%	0.0%	0.0%	0.0%	0.0%	0.0%	3.7%	0.0%	0.0%	0.0%	0.0%	2.2%	0.0%	0.0%	0.0%	0.0%	0.0%	3.0%
Pedestrians	0	0	0	0	3	4	0	0	0	0	0	0	0	0	0	0	0	4	0
% Pedestrians	0.0%	0.0%	0.0%	0.0%	100.0%	100.0%	0.0%	0.0%	0.0%	0.0%	0.0%	0.0%	0.0%	0.0%	0.0%	0.0%	0.0%	100.0%	0.0%
Bicycles on Crosswalk	0	0	0	0	0	0	0	0	0	0	0	0	0	0	0	0	0	0	0
% Bicycles on Crosswalk	0.0%	0.0%	0.0%	0.0%	0.0%	0.0%	0.0%	0.0%	0.0%	0.0%	0.0%	0.0%	0.0%	0.0%	0.0%	0.0%	0.0%	0.0%	0.0%

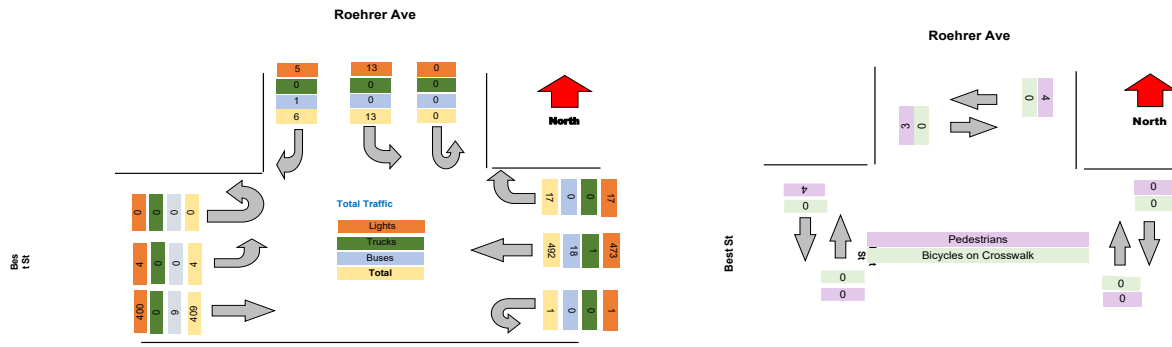

Turning Movement Peak Hour Data (PM)
 4:15:00 PM

Leg Direction	Roehrer Ave Southbound						Best St Westbound						Best St Eastbound						Total
	Right	Left	U-Turn	App Total	Peds CW	Peds CCW	Right	Thru	U-Turn	App Total	Peds CW	Peds CCW	Thru	Left	U-Turn	App Total	Peds CW	Peds CCW	
4:15:00 PM	4	8	0	12	1	1	3	110	0	113	0	0	139	4	0	143	0	0	268
4:30:00 PM	3	4	0	7	1	1	5	87	0	92	1	1	166	4	0	170	0	0	269
4:45:00 PM	4	4	0	8	0	0	3	97	0	100	0	1	123	3	0	126	0	0	234
5:00:00 PM	1	5	0	6	1	0	2	101	0	103	0	1	138	0	0	138	0	0	247
Grand Total	12	21	0	33	3	2	13	395	0	408	1	3	566	11	0	577	0	0	1018
% Approach	36.4%	63.6%	0.0%	0.0%	0.0%	0.0%	3.2%	96.8%	0.0%	0.0%	0.0%	0.0%	98.1%	1.9%	0.0%	0.0%	0.0%	0.0%	
% Total	1.2%	2.1%	0.0%	3.2%	0.0%	0.0%	1.3%	38.8%	0.0%	40.1%	0.0%	0.0%	55.6%	1.1%	0.0%	56.7%	0.0%	0.0%	
PHF	0.750	0.656	0.000	0.688	0.000	0.000	0.650	0.898	0.000	0.903	0.000	0.000	0.852	0.688	0.000	0.849	0.000	0.000	0.946
Lights	11	20	0	31	0	0	13	384	0	397	0	0	548	11	0	559	0	0	987
% Lights	91.7%	95.2%	0.0%	93.9%	0.0%	0.0%	100.0%	97.2%	0.0%	97.3%	0.0%	0.0%	96.8%	100.0%	0.0%	96.9%	0.0%	0.0%	97.0%
Trucks	0	0	0	0	0	0	0	0	0	0	0	0	0	0	0	0	0	0	0
% Trucks	0.0%	0.0%	0.0%	0.0%	0.0%	0.0%	0.0%	0.0%	0.0%	0.0%	0.0%	0.0%	0.0%	0.0%	0.0%	0.0%	0.0%	0.0%	0.0%
Buses	1	1	0	2	0	0	0	11	0	11	0	0	18	0	0	18	0	0	31
% Buses	8.3%	4.8%	0.0%	0.0%	0.0%	0.0%	0.0%	2.8%	0.0%	0.0%	0.0%	0.0%	3.2%	0.0%	0.0%	0.0%	0.0%	0.0%	3.0%
Pedestrians	0	0	0	0	3	2	0	0	0	0	1	3	0	0	0	0	0	0	0
% Pedestrians	0.0%	0.0%	0.0%	0.0%	100.0%	100.0%	0.0%	0.0%	0.0%	0.0%	100.0%	100.0%	0.0%	0.0%	0.0%	0.0%	0.0%	0.0%	0.0%
Bicycles on Crosswalk	0	0	0	0	0	0	0	0	0	0	0	0	0	0	0	0	0	0	0
% Bicycles on Crosswalk	0.0%	0.0%	0.0%	0.0%	0.0%	0.0%	0.0%	0.0%	0.0%	0.0%	0.0%	0.0%	0.0%	0.0%	0.0%	0.0%	0.0%	0.0%	0.0%

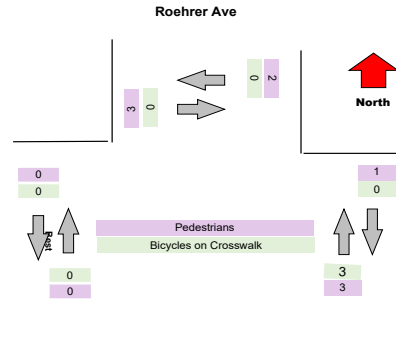
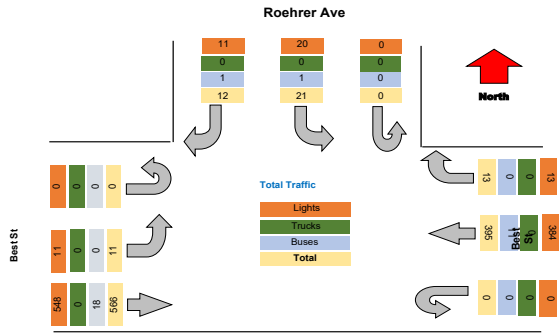

Intersection: Elm St Pine St
 Location: Kennett Square, PA
 Site: 01
 Survey Date: Wednesday, 04-28-2021
 GPS: 42.948550, -72.790034



Project	LaBella
Project Code	LaBella
Site Name	U
Legs and Movements	All Processed Legs & Movements
Bin Size	15 minutes
Survey Date	2021-11-04, Thursday
Location	U
Latitude and Longitude	42.903791, -78.849141

	Start	End	PHF
Forced Peak AM	2021/11/04 07:30:00	2021/11/04 08:30:00	0.8635
Forced Peak PM	2021/11/04 16:30:00	2021/11/04 17:30:00	0.9809
AM Peak	2021/11/04 07:30:00	2021/11/04 08:30:00	0.8635
PM Peak	2021/11/04 16:15:00	2021/11/04 17:15:00	0.9658

Turning Movement Data

Leg Direction	Roehrer Ave Southbound						Best St Westbound						Best St Eastbound						Total
	Right	Left	U-Turn	App Total	Peds CW	Peds CCW	Right	Thru	U-Turn	App Total	Peds CW	Peds CCW	Thru	Left	U-Turn	App Total	Peds CW	Peds CCW	
Start Time																			
6:30:00 AM	0	0	0	0	0	0	2	101	0	103	0	0	40	0	0	40	0	0	
6:45:00 AM	0	1	0	1	1	0	1	99	0	100	0	0	43	0	0	43	1	3	
Hourly Total	0	1	0	1	1	0	3	200	0	203	0	0	83	0	0	83	1	3	
7:00:00 AM	0	3	0	3	2	1	3	68	0	72	0	0	47	0	0	47	2	0	
7:15:00 AM	2	3	0	5	1	0	7	88	0	95	0	0	63	0	0	63	0	1	
7:30:00 AM	1	2	0	3	0	0	4	110	0	114	0	0	97	0	0	97	0	0	
7:45:00 AM	0	5	0	5	0	1	2	142	0	145	0	0	130	2	0	132	0	0	
Hourly Total	3	13	0	16	3	2	16	408	0	426	0	0	337	2	0	339	2	1	
8:00:00 AM	0	4	0	4	0	0	7	134	0	141	1	0	117	1	0	119	0	3	
8:15:00 AM	2	1	0	3	0	1	6	121	0	128	0	0	83	0	0	83	0	0	
Hourly Total	2	5	0	7	0	1	13	255	0	269	1	0	200	1	0	202	0	3	
4:00:00 PM	5	5	0	10	0	0	4	92	0	96	0	1	176	4	0	180	0	0	
4:15:00 PM	2	5	0	7	2	0	6	93	0	99	0	0	133	2	0	135	0	0	
4:30:00 PM	2	6	0	8	0	0	4	67	0	71	0	0	146	4	0	150	0	1	
4:45:00 PM	4	3	0	7	0	4	5	84	0	89	0	0	131	4	0	135	0	0	
Hourly Total	13	19	0	32	2	4	19	336	0	355	0	1	586	14	0	600	0	1	
5:00:00 PM	3	4	0	7	0	1	7	79	0	86	0	1	137	0	0	137	0	0	
5:15:00 PM	4	5	0	9	1	0	5	99	0	104	0	0	120	3	0	123	0	0	
5:30:00 PM	5	6	0	11	0	0	2	94	0	96	0	0	109	1	0	110	1	1	
5:45:00 PM	2	4	0	6	0	1	8	84	0	92	2	2	107	1	0	108	0	1	
Hourly Total	14	19	0	33	1	2	22	356	0	378	2	3	473	5	0	478	1	2	
Grand Total	32	57	0	89	7	9	73	1555	0	1631	3	4	1679	22	0	1702	4	10	
% Approach	36.0%	64.0%	0.0%	0.0%	0.0%	0.0%	4.5%	95.3%	0.0%	0.0%	0.0%	0.0%	98.6%	1.3%	0.0%	0.0%	0.0%	0.0%	
% Total	0.9%	1.7%	0.0%	2.6%	0.0%	0.0%	2.1%	45.4%	0.0%	47.7%	0.0%	0.0%	49.1%	0.6%	0.0%	49.7%	0.0%	0.0%	
Lights	32	55	0	87	0	0	71	1498	0	1569	0	0	1629	22	0	1651	0	0	
% Lights	###	96.5%	0.0%	97.8%	0.0%	0.0%	97.3%	96.3%	0.0%	96.2%	0.0%	0.0%	97.0%	100.0%	0.0%	97.0%	0.0%	0.0%	
Trucks	0	0	0	0	0	0	0	1	0	1	0	0	0	0	0	0	0	0	
% Trucks	0.0%	0.0%	0.0%	0.0%	0.0%	0.0%	0.0%	0.1%	0.0%	0.1%	0.0%	0.0%	0.0%	0.0%	0.0%	0.0%	0.0%	0.0%	
Buses	0	2	0	2	0	0	2	56	0	58	0	0	50	0	0	50	0	0	
% Buses	0.0%	3.5%	0.0%	0.0%	0.0%	0.0%	0.0%	3.6%	0.0%	0.0%	0.0%	0.0%	3.0%	0.0%	0.0%	0.0%	0.0%	0.0%	
Pedestrians	0	0	0	0	7	9	0	0	0	0	3	4	0	0	0	0	4	10	
% Pedestrians	0.0%	0.0%	0.0%	0.0%	100.0%	100.0%	0.0%	0.0%	0.0%	0.0%	100.0%	100.0%	0.0%	0.0%	0.0%	0.0%	100.0%	100.0%	
Bicycles on Crosswalk	0	0	0	0	0	0	0	0	0	0	0	0	0	0	0	0	0	0	
% Bicycles on Crosswalk	0.0%	0.0%	0.0%	0.0%	0.0%	0.0%	0.0%	0.0%	0.0%	0.0%	0.0%	0.0%	0.0%	0.0%	0.0%	0.0%	0.0%	0.0%	

Turning Movement Data Plot

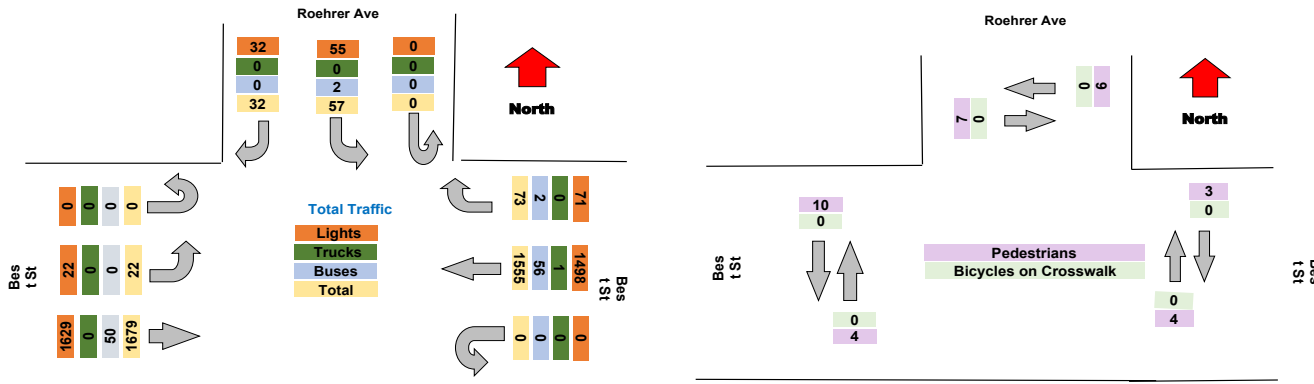

Turning Movement Peak Hour Data (AM)

7:30:00 AM

Leg Direction	Roehrer Ave Southbound						Best St Westbound						Best St Eastbound						Total
	Right	Left	U-Turn	App Total	Peds CW	Peds CCW	Right	Thru	U-Turn	App Total	Peds CW	Peds CCW	Thru	Left	U-Turn	App Total	Peds CW	Peds CCW	
7:30:00 AM	1	2	0	3	0	0	4	110	0	114	0	0	97	0	0	97	0	0	214
7:45:00 AM	0	5	0	5	0	1	2	142	0	145	0	0	130	2	0	132	0	0	282
8:00:00 AM	0	4	0	4	0	0	7	134	0	141	1	0	117	1	0	119	0	3	264
8:15:00 AM	2	1	0	3	0	1	6	121	0	128	0	0	83	0	0	83	0	0	214
Grand Total	3	12	0	15	0	2	19	507	0	528	1	0	427	3	0	431	0	3	974
% Approach	20.0%	80.0%	0.0%	0.0%	0.0%	0.0%	3.6%	96.0%	0.0%	0.0%	0.0%	0.0%	99.1%	0.7%	0.0%	0.0%	0.0%	0.0%	
% Total	0.3%	1.2%	0.0%	1.5%	0.0%	0.0%	2.0%	52.1%	0.0%	54.2%	0.0%	0.0%	43.8%	0.3%	0.0%	44.3%	0.0%	0.0%	
PHF	0.375	0.600	0.000	0.750	0.000	0.000	0.679	0.893	0.000	0.910	0.000	0.000	0.821	0.375	0.000	0.816	0.000	0.000	0.863
Lights	3	12	0	15	0	0	19	489	0	508	0	0	416	3	0	419	0	0	942
% Lights	###	100.0%	0.0%	100.0%	0.0%	0.0%	100.0%	96.4%	0.0%	96.2%	0.0%	0.0%	97.4%	100.0%	0.0%	97.2%	0.0%	0.0%	96.7%
Trucks	0	0	0	0	0	0	0	0	0	0	0	0	0	0	0	0	0	0	0
% Trucks	0.0%	0.0%	0.0%	0.0%	0.0%	0.0%	0.0%	0.0%	0.0%	0.0%	0.0%	0.0%	0.0%	0.0%	0.0%	0.0%	0.0%	0.0%	0.0%
Buses	0	0	0	0	0	0	0	18	0	18	0	0	11	0	0	11	0	0	29
% Buses	0.0%	0.0%	0.0%	0.0%	0.0%	0.0%	0.0%	3.6%	0.0%	0.0%	0.0%	0.0%	2.6%	0.0%	0.0%	0.0%	0.0%	0.0%	3.0%
Pedestrians	0	0	0	0	0	2	0	0	0	1	0	0	0	0	0	0	0	3	0
% Pedestrians	0.0%	0.0%	0.0%	0.0%	0.0%	100.0%	0.0%	0.0%	0.0%	0.0%	100.0%	0.0%	0.0%	0.0%	0.0%	0.0%	0.0%	100.0%	0.0%
Bicycles on Crosswalk	0	0	0	0	0	0	0	0	0	0	0	0	0	0	0	0	0	0	0
% Bicycles on Crosswalk	0.0%	0.0%	0.0%	0.0%	0.0%	0.0%	0.0%	0.0%	0.0%	0.0%	0.0%	0.0%	0.0%	0.0%	0.0%	0.0%	0.0%	0.0%	0.0%

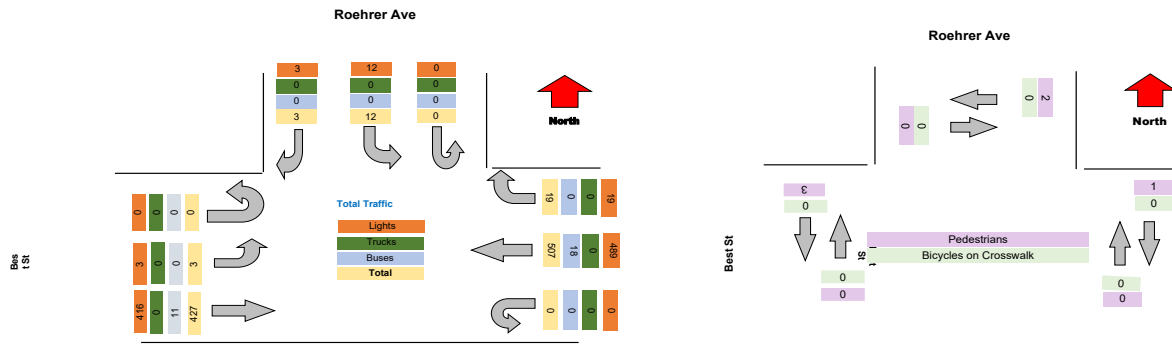

Turning Movement Peak Hour Data (PM)
 4:15:00 PM

Leg Direction	Roehrer Ave Southbound						Best St Westbound						Best St Eastbound						Total
	Right	Left	U-Turn	App Total	Peds CW	Peds CCW	Right	Thru	U-Turn	App Total	Peds CW	Peds CCW	Thru	Left	U-Turn	App Total	Peds CW	Peds CCW	
4:15:00 PM	2	5	0	7	2	0	6	93	0	99	0	0	133	2	0	135	0	0	241
4:30:00 PM	2	6	0	8	0	0	4	67	0	71	0	0	146	4	0	150	0	1	229
4:45:00 PM	4	3	0	7	0	4	5	84	0	89	0	0	131	4	0	135	0	0	231
5:00:00 PM	3	4	0	7	0	1	7	79	0	86	0	1	137	0	0	137	0	0	230
Grand Total	11	18	0	29	2	5	22	323	0	345	0	1	547	10	0	557	0	1	931
% Approach	37.9%	62.1%	0.0%	0.0%	0.0%	0.0%	6.4%	93.6%	0.0%	0.0%	0.0%	0.0%	98.2%	1.8%	0.0%	0.0%	0.0%	0.0%	
% Total	1.2%	1.9%	0.0%	3.1%	0.0%	0.0%	2.4%	34.7%	0.0%	37.1%	0.0%	0.0%	58.8%	1.1%	0.0%	59.8%	0.0%	0.0%	
PHF	0.688	0.750	0.000	0.906	0.000	0.000	0.786	0.868	0.000	0.871	0.000	0.000	0.937	0.625	0.000	0.928	0.000	0.000	0.966
Lights	11	18	0	29	0	0	22	310	0	332	0	0	535	10	0	545	0	0	906
% Lights	#####	100.0%	0.0%	100.0%	0.0%	0.0%	100.0%	96.0%	0.0%	96.2%	0.0%	0.0%	97.8%	100.0%	0.0%	97.8%	0.0%	0.0%	97.3%
Trucks	0	0	0	0	0	0	0	0	0	0	0	0	0	0	0	0	0	0	0
% Trucks	0.0%	0.0%	0.0%	0.0%	0.0%	0.0%	0.0%	0.0%	0.0%	0.0%	0.0%	0.0%	0.0%	0.0%	0.0%	0.0%	0.0%	0.0%	0.0%
Buses	0	0	0	0	0	0	0	13	0	13	0	0	12	0	0	12	0	0	25
% Buses	0.0%	0.0%	0.0%	0.0%	0.0%	0.0%	0.0%	4.0%	0.0%	0.0%	0.0%	0.0%	2.2%	0.0%	0.0%	0.0%	0.0%	0.0%	2.7%
Pedestrians	0	0	0	0	2	5	0	0	0	0	1	0	0	0	0	0	0	1	0
% Pedestrians	0.0%	0.0%	0.0%	0.0%	100.0%	100.0%	0.0%	0.0%	0.0%	0.0%	100.0%	0.0%	0.0%	0.0%	0.0%	0.0%	0.0%	100.0%	0.0%
Bicycles on Crosswalk	0	0	0	0	0	0	0	0	0	0	0	0	0	0	0	0	0	0	0
% Bicycles on Crosswalk	0.0%	0.0%	0.0%	0.0%	0.0%	0.0%	0.0%	0.0%	0.0%	0.0%	0.0%	0.0%	0.0%	0.0%	0.0%	0.0%	0.0%	0.0%	0.0%

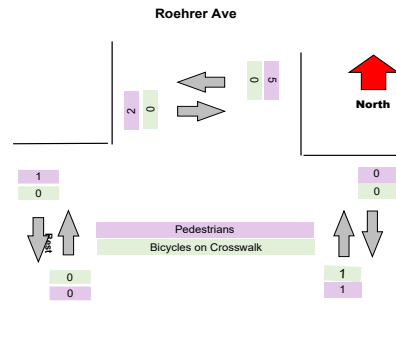
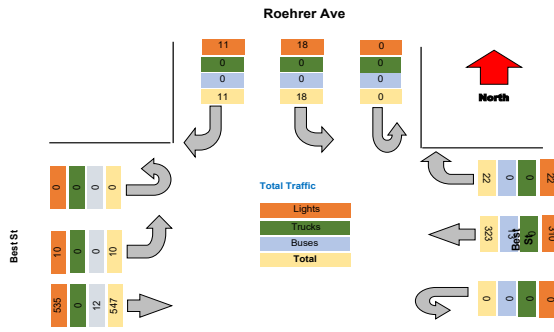

Project : VBH Malta NY
 Site : Site 4
 Location : 42.948550, -73.790036
 Survey Date : 2021-04-28, Wednesday

Turning Movement Data Plot

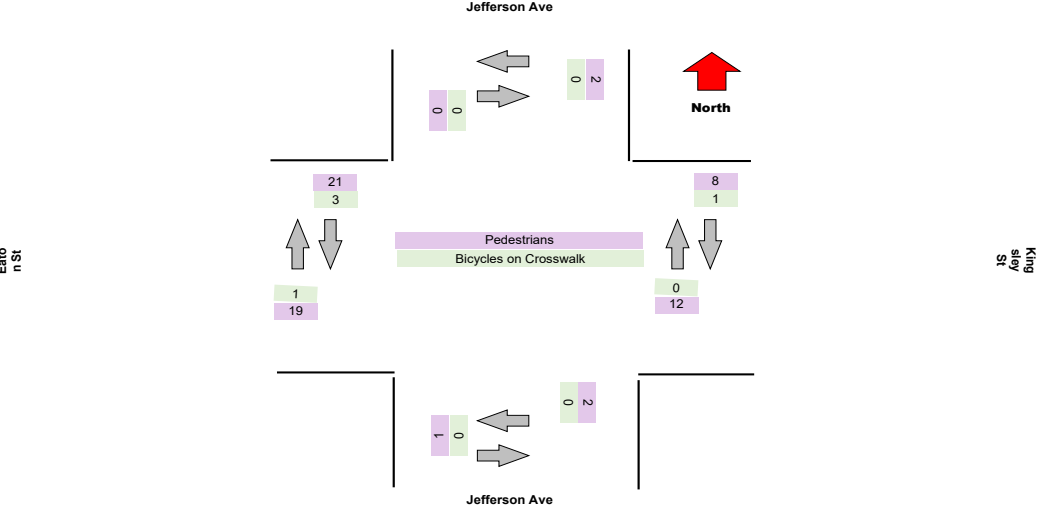
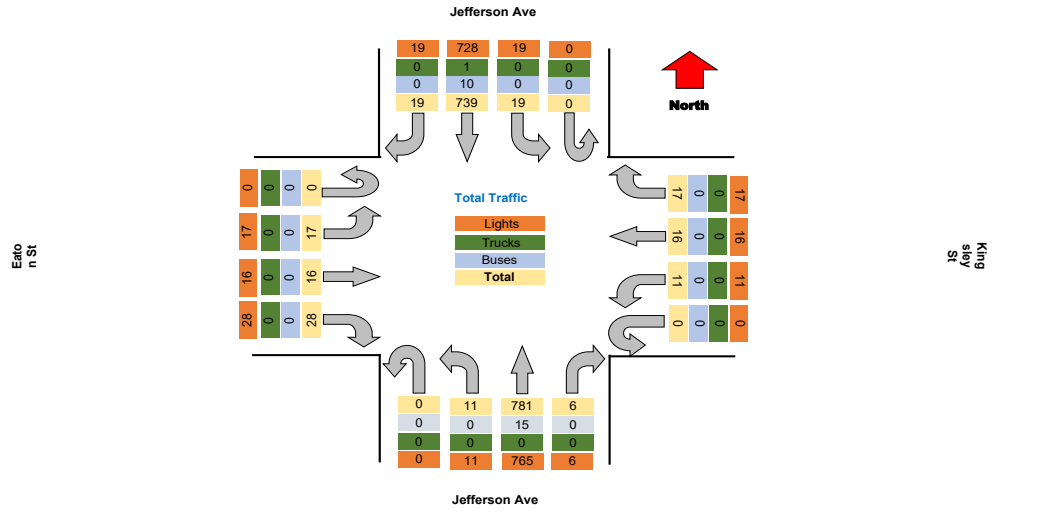

Turning Movement Peak Hour Data (AM)

7:30:00 AM

Leg Direction	Jefferson Ave					Kingsley St					Jefferson Ave					Eaton St					Total								
	Right	Thru	Left	U-Turn	App Total	Peds CW	Peds CCW	Right	Thru	Left	U-Turn	App Total	Peds CW	Peds CCW	Right	Thru	Left	U-Turn	App Total	Peds CW		Peds CCW							
7:30:00 AM	2	23	1	0	26	0	0	2	2	2	0	6	0	1	0	25	1	0	27	0	0	0	2	2	1	61			
7:45:00 AM	0	26	1	0	27	0	1	1	0	1	0	3	1	0	0	27	0	0	28	0	0	1	0	0	3	59			
8:00:00 AM	1	35	2	0	38	0	0	2	0	1	0	3	0	1	1	33	0	0	35	0	0	1	0	1	2	78			
8:15:00 AM	1	48	1	0	50	0	0	1	1	1	0	3	1	0	0	28	2	0	31	1	0	0	2	2	4	1	88		
Grand Total	4	132	5	0	141	0	1	6	3	5	0	15	2	2	1	113	3	0	121	1	0	2	4	3	9	288			
% Approach	2.8%	93.6%	3.5%	0.0%	0.0%	0.0%	0.0%	40.0%	20.0%	33.3%	0.0%	0.0%	0.0%	0.0%	0.8%	93.4%	2.5%	0.0%	0.0%	0.0%	0.0%	22.2%	44.4%	33.3%	0.0%	0.0%	0.0%		
% Total	1.4%	46.2%	1.7%	0.0%	49.3%	0.0%	0.0%	2.1%	1.0%	1.7%	0.0%	5.2%	0.0%	0.0%	0.3%	39.5%	1.0%	0.0%	42.3%	0.0%	0.0%	0.7%	1.4%	1.0%	0.0%	3.1%	0.0%	0.0%	
PHF	0.500	0.688	0.625	0.000	0.705	0.000	0.000	0.750	0.375	0.625	0.000	0.625	0.000	0.000	0.250	0.856	0.375	0.000	0.864	0.000	0.000	0.500	1.500	0.375	0.000	0.563	0.000	0.000	
Lights	4	131	5	0	140	0	0	6	3	5	0	14	0	0	1	108	3	0	112	0	0	2	4	3	0	9	0	0	
% Lights	100.0%	99.2%	100.0%	0.0%	99.3%	0.0%	0.0%	100.0%	100.0%	100.0%	0.0%	93.3%	0.0%	0.0%	100.0%	95.6%	100.0%	0.0%	92.6%	0.0%	0.0%	100.0%	100.0%	100.0%	0.0%	100.0%	0.0%	0.0%	
Trucks	0	0	0	0	0	0	0	0	0	0	0	0	0	0	0	0	0	0	0	0	0	0	0	0	0	0	0	0	
% Trucks	0.0%	0.0%	0.0%	0.0%	0.0%	0.0%	0.0%	0.0%	0.0%	0.0%	0.0%	0.0%	0.0%	0.0%	0.0%	0.0%	0.0%	0.0%	0.0%	0.0%	0.0%	0.0%	0.0%	0.0%	0.0%	0.0%	0.0%	0.0%	
Buses	0	1	0	0	1	0	0	0	0	0	0	0	0	0	0	5	0	0	5	0	0	0	0	0	0	0	0	0	
% Buses	0.0%	0.8%	0.0%	0.0%	0.0%	0.0%	0.0%	0.0%	0.0%	0.0%	0.0%	0.0%	0.0%	0.0%	0.0%	4.4%	0.0%	0.0%	0.0%	0.0%	0.0%	0.0%	0.0%	0.0%	0.0%	0.0%	0.0%	0.0%	
Pedestrians	0	0	0	0	0	0	1	0	0	0	0	2	2	0	0	0	0	0	1	0	0	0	0	0	0	3	4	0	
% Pedestrians	0.0%	0.0%	0.0%	0.0%	0.0%	0.0%	100.0%	0.0%	0.0%	0.0%	0.0%	0.0%	100.0%	100.0%	0.0%	0.0%	0.0%	0.0%	0.0%	0.0%	100.0%	0.0%	0.0%	0.0%	0.0%	100.0%	80.0%	0.0%	
Bicycles on Crosswalk	0	0	0	0	0	0	0	0	0	0	0	0	0	0	0	0	0	0	0	0	0	0	0	0	0	0	0	1	0
% Bicycles on Crosswalk	0.0%	0.0%	0.0%	0.0%	0.0%	0.0%	0.0%	0.0%	0.0%	0.0%	0.0%	0.0%	0.0%	0.0%	0.0%	0.0%	0.0%	0.0%	0.0%	0.0%	0.0%	0.0%	0.0%	0.0%	0.0%	0.0%	20.0%	0.0%	

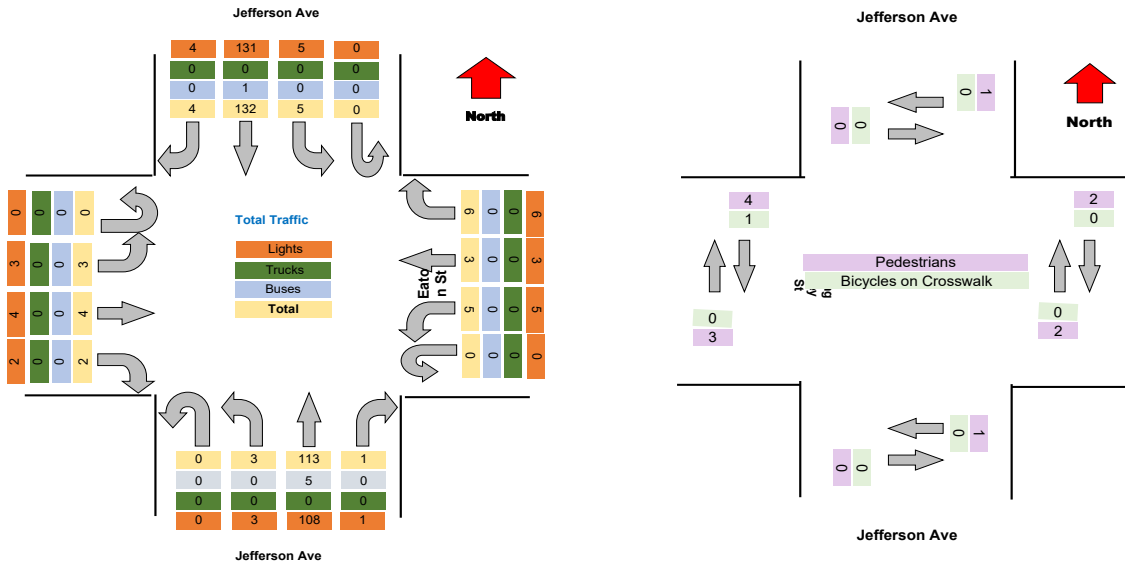

Turning Movement Peak Hour Data (PM)

4:15:00 PM

Leg Direction	Jefferson Ave					Kingsley St					Jefferson Ave					Eaton St					Total									
	Southbound					Westbound					Northbound					Eastbound														
	Right	Thru	Left	U-Turn	App Total	Peds CW	Peds CCW	Right	Thru	Left	U-Turn	App Total	Peds CW	Peds CCW	Right	Thru	Left	U-Turn	App Total	Peds CW		Peds CCW								
4:15:00 PM	1	60	1	0	62	0	0	1	3	1	0	5	1	1	0	67	0	0	67	0	0	7	1	0	0	8	2	1	142	
4:30:00 PM	2	80	3	0	85	0	1	0	0	1	0	1	1	1	0	82	2	0	84	0	0	3	1	2	0	6	3	4	176	
4:45:00 PM	4	60	2	0	66	0	0	0	1	1	0	2	0	3	2	72	0	0	74	0	0	1	3	1	0	5	0	1	147	
5:00:00 PM	0	61	2	0	63	0	0	1	4	1	0	6	3	1	2	66	3	0	69	1	1	0	1	3	0	4	0	3	164	
Grand Total	7	261	8	0	276	0	0	2	8	4	0	14	8	6	4	307	5	0	316	1	1	11	6	6	0	23	3	9	629	
% Approach	2.5%	94.6%	2.9%	0.0%	0.0%	0.0%	0.0%	14.3%	57.1%	28.6%	0.0%	0.0%	0.0%	0.0%	1.3%	97.2%	1.6%	0.0%	0.0%	0.0%	0.0%	47.8%	26.1%	26.1%	0.0%	0.0%	0.0%	0.0%	0.0%	
% Total	1.1%	41.5%	1.3%	0.0%	43.9%	0.0%	0.0%	0.3%	1.3%	0.6%	0.0%	2.2%	0.0%	0.0%	0.6%	48.8%	0.8%	0.0%	50.2%	0.0%	0.0%	1.7%	1.0%	1.0%	0.0%	3.7%	0.0%	0.0%	0.0%	
PHF	0.438	0.816	0.667	0.000	0.812	0.000	0.000	0.500	0.500	1.000	0.000	0.583	0.000	0.000	0.500	0.892	0.417	0.000	0.868	0.000	0.000	0.393	0.500	0.500	0.000	0.719	0.000	0.000	0.893	
Lights	7	257	8	0	272	0	0	2	8	4	0	14	0	0	4	301	5	0	310	0	0	11	6	6	0	23	0	0	619	
% Lights	100.0%	98.5%	100.0%	0.0%	98.6%	0.0%	0.0%	100.0%	100.0%	100.0%	0.0%	100.0%	0.0%	0.0%	100.0%	98.0%	100.0%	0.0%	98.1%	0.0%	0.0%	100.0%	100.0%	100.0%	0.0%	100.0%	0.0%	0.0%	98.4%	
Trucks	0	1	0	0	1	0	0	0	0	0	0	0	0	0	0	0	0	0	0	0	0	0	0	0	0	0	0	0	1	
% Trucks	0.0%	0.4%	0.0%	0.0%	0.4%	0.0%	0.0%	0.0%	0.0%	0.0%	0.0%	0.0%	0.0%	0.0%	0.0%	0.0%	0.0%	0.0%	0.0%	0.0%	0.0%	0.0%	0.0%	0.0%	0.0%	0.0%	0.0%	0.0%	0.2%	
Buses	0	3	0	0	3	0	0	0	0	0	0	0	0	0	0	5	0	0	5	0	0	0	0	0	0	0	0	0	8	
% Buses	0.0%	1.1%	0.0%	0.0%	0.0%	0.0%	0.0%	0.0%	0.0%	0.0%	0.0%	0.0%	0.0%	0.0%	0.0%	1.6%	0.0%	0.0%	0.0%	0.0%	0.0%	0.0%	0.0%	0.0%	0.0%	0.0%	0.0%	0.0%	1.3%	
Pedestrians	0	0	0	0	0	0	0	0	0	0	0	4	6	0	0	0	0	0	0	1	1	0	0	0	0	0	4	8	0	
% Pedestrians	0.0%	0.0%	0.0%	0.0%	0.0%	0.0%	100.0%	0.0%	0.0%	0.0%	0.0%	0.0%	80.0%	100.0%	0.0%	0.0%	0.0%	0.0%	0.0%	0.0%	100.0%	100.0%	0.0%	0.0%	0.0%	0.0%	0.0%	80.0%	88.9%	0.0%
Bicycles on Crosswalk	0	0	0	0	0	0	0	0	0	0	0	1	0	0	0	0	0	0	0	0	0	0	0	0	0	0	1	1	0	
% Bicycles on Crosswalk	0.0%	0.0%	0.0%	0.0%	0.0%	0.0%	0.0%	0.0%	0.0%	0.0%	0.0%	20.0%	0.0%	0.0%	0.0%	0.0%	0.0%	0.0%	0.0%	0.0%	0.0%	0.0%	0.0%	0.0%	0.0%	0.0%	0.0%	20.0%	11.1%	0.0%

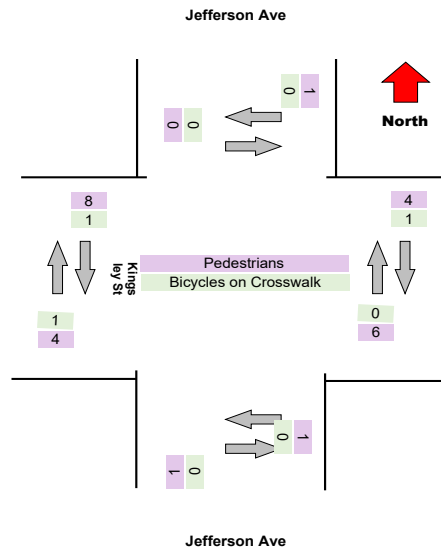
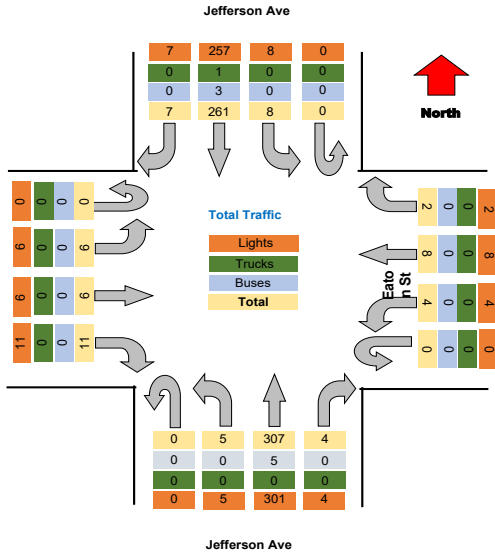

Project : VBH Malta NY
 Site : Site 4
 Location : 42.948550, -73.790036

TSTData.com

Survey Date : 2021-04-28, Wednesday

Project	LaBella
Project Code	LaBella
Site Name	V
Legs and Movements	All Processed Legs & Move
Bin Size	15 minutes
Survey Date	2021-11-03, Wednesday
Location	V
Latitude and Longitude	42.908321, -78.853973

	Start	End	PHF
Forced Peak AM	2021/11/03 07:30:00	2021/11/03 08:30:00	0.87
Forced Peak PM	2021/11/03 16:30:00	2021/11/03 17:30:00	0.86
AM Peak	2021/11/03 07:30:00	2021/11/03 08:30:00	0.87
PM Peak	2021/11/03 16:15:00	2021/11/03 17:15:00	0.89

Turning Movement Data

Leg Direction	Jefferson Ave								Kingsley St								Eaton St								Total												
	Southbound				Northbound				Westbound				Eastbound				Northbound				Eastbound																
	Right	Thru	Left	U-Turn	App Total	Peds CW	Peds CCW		Right	Thru	Left	U-Turn	App Total	Peds CW	Peds CCW		Right	Thru	Left	U-Turn	App Total	Peds CW	Peds CCW			Right	Thru	Left	U-Turn	App Total	Peds CW	Peds CCW					
6:30:00 AM	0	11	2	0	13	0	0	1	2	0	0	3	1	0	0	0	0	0	20	1	0	22	0	0	0	0	0	0	0	1	0	0	1	2	0	39	
6:45:00 AM	1	21	1	0	23	0	0	0	0	0	0	0	0	0	0	0	0	1	24	1	0	26	0	0	0	0	0	0	1	0	2	0	3	2	0	52	
Hourly Total	1	32	3	0	36	0	0	1	2	0	0	3	1	0	0	0	0	1	44	2	0	46	0	0	0	0	0	0	1	1	2	0	4	4	0	91	
7:00:00 AM	0	29	1	0	30	0	0	1	3	0	0	4	0	0	1	1	0	1	43	0	0	44	0	0	0	0	0	0	1	0	0	0	1	1	2	79	
7:15:00 AM	0	32	1	0	33	0	0	0	1	0	0	1	0	0	2	37	1	0	2	37	1	0	40	0	0	0	0	0	0	1	1	1	0	3	0	0	77
7:30:00 AM	1	38	1	0	40	0	0	1	3	1	0	5	0	0	0	0	0	0	34	0	0	34	0	0	0	0	0	0	1	0	0	0	1	2	0	80	
7:45:00 AM	1	65	0	0	66	0	1	0	3	1	0	5	0	0	0	0	0	0	40	1	0	41	0	0	0	0	0	0	0	3	0	0	3	2	0	115	
Hourly Total	2	164	3	0	169	0	1	2	10	2	0	15	0	0	3	154	2	0	3	154	2	0	159	0	0	0	0	0	0	3	4	1	0	8	5	2	351
8:00:00 AM	1	58	1	0	60	1	0	0	2	1	0	3	0	2	1	46	2	0	1	46	2	0	51	0	0	0	0	0	0	0	3	0	0	3	0	1	117
8:15:00 AM	1	36	3	0	40	0	0	0	4	0	0	4	0	0	0	45	1	0	0	45	1	0	46	0	0	0	0	0	0	2	1	2	0	5	0	1	95
Hourly Total	2	94	4	0	100	1	0	0	6	1	0	7	0	2	1	91	3	0	1	91	3	0	97	0	0	0	0	0	0	2	4	2	0	8	0	2	212
4:00:00 PM	2	62	3	0	67	0	0	4	0	1	0	5	0	0	0	87	1	0	0	87	1	0	88	0	0	0	0	0	0	6	3	2	0	11	1	2	171
4:15:00 PM	2	70	1	0	73	0	0	3	1	0	0	4	0	0	0	81	1	0	0	81	1	0	82	0	0	0	0	0	0	7	0	5	0	12	0	0	171
4:30:00 PM	2	85	3	0	90	0	0	4	0	3	0	7	1	1	1	64	0	0	0	64	0	0	65	0	0	0	0	0	0	2	6	4	0	12	0	0	174
4:45:00 PM	3	52	4	0	59	0	0	3	1	2	0	6	1	1	1	78	1	0	0	78	1	0	80	0	0	0	0	0	0	2	2	2	0	6	1	0	151
Hourly Total	9	269	11	0	289	0	0	14	2	6	0	22	2	2	2	310	3	0	2	310	3	0	315	0	0	0	0	0	0	17	11	13	0	41	2	2	667
5:00:00 PM	1	81	1	0	83	0	0	2	8	2	0	12	0	0	0	84	3	0	0	84	3	0	87	0	1	0	0	0	0	5	3	3	0	11	2	1	193
5:15:00 PM	2	60	1	0	63	0	0	2	2	0	0	4	0	0	0	75	0	0	0	75	0	0	75	0	0	0	0	0	0	4	0	3	0	7	0	1	149
5:30:00 PM	1	72	1	0	74	0	0	0	3	0	0	3	0	1	1	67	0	0	0	67	0	0	68	0	0	0	0	0	0	3	2	2	0	7	0	0	152
5:45:00 PM	1	58	3	0	62	0	1	0	0	0	0	1	0	1	1	54	2	0	0	54	2	0	57	0	0	0	0	0	0	0	2	0	0	2	2	1	121
Hourly Total	5	271	6	0	282	0	1	4	13	2	0	19	1	1	2	280	5	0	2	280	5	0	287	0	1	0	0	0	0	12	7	8	0	27	4	3	615
Grand Total	19	830	27	0	876	1	2	21	33	11	0	66	4	6	9	879	15	0	9	879	15	0	906	0	1	0	0	0	0	35	27	26	0	88	15	9	1936
% Approach	2.2%	94.7%	3.1%	0.0%	0.0%	0.0%	0.0%	31.8%	50.0%	16.7%	0.0%	0.0%	0.0%	0.0%	1.0%	97.0%	1.7%	0.0%	0.0%	0.0%	0.0%	0.0%	0.0%	0.0%	0.0%	0.0%	0.0%	0.0%	0.0%	0.0%	0.0%	0.0%	0.0%	0.0%			
% Total	1.0%	42.9%	1.4%	0.0%	45.2%	0.0%	0.0%	1.1%	1.7%	0.6%	0.0%	3.4%	0.0%	0.0%	0.5%	45.4%	0.8%	0.0%	0.0%	0.0%	0.0%	0.0%	0.0%	0.0%	0.0%	0.0%	1.8%	1.4%	1.3%	0.0%	4.5%	0.0%	0.0%	0.0%			
Lights	17	786	25	0	828	0	0	21	33	11	0	65	0	0	8	842	15	0	0	0	0	0	0	0	0	0	35	24	26	0	85	0	0	1643			
% Lights	89.5%	94.7%	92.6%	0.0%	94.5%	0.0%	0.0%	100.0%	100.0%	100.0%	0.0%	98.8%	0.0%	0.0%	88.9%	95.8%	100.0%	0.0%	95.8%	0.0%	0.0%	0.0%	0.0%	0.0%	0.0%	0.0%	100.0%	88.8%	100.0%	0.0%	96.6%	0.0%	0.0%	95.2%			
Trucks	0	2	0	0	2	0	0	0	0	0	0	0	0	0	0	1	0	0	0	0	0	0	0	0	0	0	0	0	0	0	0	0	0	0	3		
% Trucks	0.0%	0.2%	0.0%	0.0%	0.2%	0.0%	0.0%	0.0%	0.0%	0.0%	0.0%	0.0%	0.0%	0.0%	0.0%	0.1%	0.0%	0.0%	0.0%	0.0%	0.0%	0.0%	0.0%	0.0%	0.0%	0.0%	0.0%	0.0%	0.0%	0.0%	0.0%	0.0%	0.0%	0.2%			
Buses	2	42	2	0	46	0	0	0	0	0	0	0	0	0	1	36	0	0	0	0	0	0	0	0	0	0	0	3	0	0	0	3	0	0	86		
% Buses	10.5%	5.1%	7.4%	0.0%	0.0%	0.0%	0.0%	0.0%	0.0%	0.0%	0.0%	0.0%	0.0%	0.0%	11.1%	4.1%	0.0%	0.0%	0.0%	0.0%	0.0%	0.0%	0.0%	0.0%	0.0%	0.0%	0.0%	11.1%	0.0%	0.0%	0.0%	0.0%	0.0%	0.0%	4.4%		
Pedestrians	0	0	0	0	0	1	2	0	0	0	0	0	4	5	0	0	0	0	0	0	0	1	0	0	0	0	0	0	0	0	0	15	8	0			
% Pedestrians	0.0%	0.0%	0.0%	0.0%	0.0%	100.0%	100.0%	0.0%	0.0%	0.0%	0.0%	0.0%	100.0%	100.0%	0.0%	0.0%	0.0%	0.0%	0.0%	0.0%	0.0%	100.0%	0.0%	0.0%	0.0%	0.0%	0.0%	0.0%	0.0%	0.0%	0.0%	100.0%	88.8%	0.0%	0.0%		
Bicycles on Crosswalk	0	0	0	0	0	0	0	0	0	0	0	0	0	0	0	0	0	0	0	0	0	0	0	0	0	0	0	0	0	0	0	0	1	0			
% Bicycles on Crosswalk	0.0%	0.0%	0.0%	0.0%	0.0%	0.0%	0.0%	0.0%	0.0%	0.0%	0.0%	0.0%	0.0%	0.0%	0.0%	0.0%	0.0%	0.0%	0.0%	0.0%	0.0%	0.0%	0.0%	0.0%	0.0%	0.0%	0.0%	0.0%	0.0%	0.0%	0.0%	11.1%	0.0%	0.0%			

Project : VBH Malta NY
 Site : Site 4
 Location : 42.948550, -73.790036
 Survey Date : 2021-04-28, Wednesday

Turning Movement Data Plot

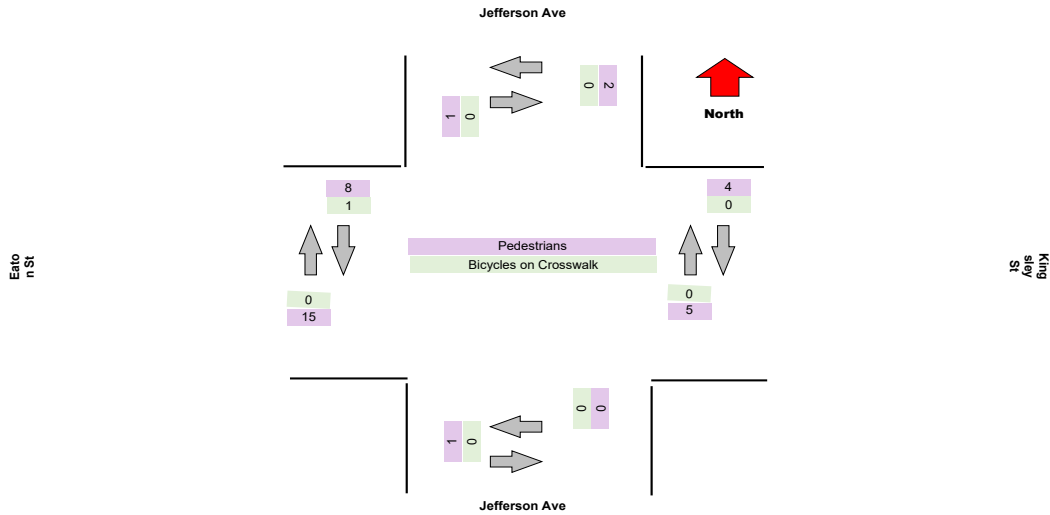
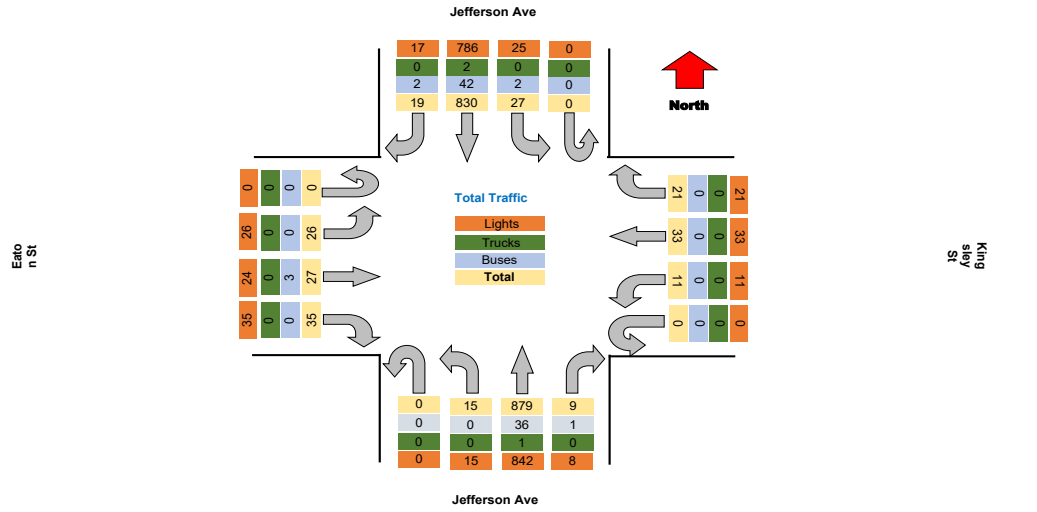

Turning Movement Peak Hour Data (AM)

7:30:00 AM

Leg Direction	Jefferson Ave								Kingsley St								Jefferson Ave								Eaton St								Total
	Southbound				Northbound				Westbound				Eastbound				Northbound				Eastbound												
Start Time	Right	Thru	Left	U-Turn	App Total	Peds CW	Peds CCW	Right	Thru	Left	U-Turn	App Total	Peds CW	Peds CCW	Right	Thru	Left	U-Turn	App Total	Peds CW	Peds CCW	Right	Thru	Left	U-Turn	App Total	Peds CW	Peds CCW					
7:30:00 AM	1	38	1	0	40	0	0	1	3	1	0	5	0	0	0	34	0	0	34	0	0	1	0	0	1	2	0	0	80				
7:45:00 AM	1	65	0	0	66	0	1	0	3	1	0	5	0	0	0	40	1	0	41	0	0	0	3	0	0	3	2	0	115				
8:00:00 AM	1	58	1	0	60	1	0	0	2	1	0	3	0	2	1	46	2	0	51	0	0	0	3	0	0	3	0	1	117				
8:15:00 AM	1	36	3	0	40	0	0	0	4	0	0	4	0	0	0	45	1	0	46	0	0	2	1	2	0	5	0	1	95				
Grand Total	4	197	5	0	206	1	0	1	12	3	0	17	0	0	1	185	4	0	172	0	0	3	7	2	0	12	4	2	407				
% Approach	1.9%	95.6%	2.4%	0.0%	0.0%	0.0%	0.0%	5.9%	70.6%	17.6%	0.0%	0.0%	0.0%	0.0%	0.6%	95.9%	2.3%	0.0%	0.0%	0.0%	0.0%	25.0%	56.3%	16.7%	0.0%	0.0%	0.0%	0.0%	8.8%				
% Total	1.0%	48.4%	1.2%	0.0%	56.6%	0.0%	0.0%	0.2%	2.9%	0.7%	0.0%	4.2%	0.0%	0.0%	0.2%	40.5%	1.0%	0.0%	42.3%	0.0%	0.0%	0.7%	1.7%	0.5%	0.0%	2.9%	0.0%	0.0%					
PHF	1.000	0.758	0.417	0.000	0.780	0.000	0.000	0.250	0.750	0.750	0.000	0.850	0.000	0.000	0.250	0.897	0.500	0.000	0.843	0.000	0.000	0.375	0.583	0.250	0.000	0.600	0.000	0.000	0.870				
Lights	4	179	4	0	187	0	0	1	12	3	0	16	0	0	1	148	4	0	153	0	0	3	6	2	0	11	0	0	367				
% Lights	100.0%	90.9%	80.0%	0.0%	90.8%	0.0%	0.0%	100.0%	100.0%	100.0%	0.0%	94.1%	0.0%	0.0%	100.0%	89.7%	100.0%	0.0%	89.0%	0.0%	0.0%	100.0%	85.7%	100.0%	0.0%	91.7%	0.0%	0.0%	90.2%				
Trucks	0	1	0	0	1	0	0	0	0	0	0	0	0	0	0	0	0	0	0	0	0	0	0	0	0	0	0	0	1				
% Trucks	0.0%	0.5%	0.0%	0.0%	0.5%	0.0%	0.0%	0.0%	0.0%	0.0%	0.0%	0.0%	0.0%	0.0%	0.0%	0.0%	0.0%	0.0%	0.0%	0.0%	0.0%	0.0%	0.0%	0.0%	0.0%	0.0%	0.0%	0.0%	0.2%				
Buses	0	17	1	0	18	0	0	0	0	0	0	0	0	0	0	17	0	0	17	0	0	0	1	0	0	1	0	0	36				
% Buses	0.0%	8.6%	20.0%	0.0%	0.0%	0.0%	0.0%	0.0%	0.0%	0.0%	0.0%	0.0%	0.0%	0.0%	0.0%	10.3%	0.0%	0.0%	0.0%	0.0%	0.0%	0.0%	14.3%	0.0%	0.0%	0.0%	0.0%	0.0%	8.8%				
Pedestrians	0	0	0	0	0	1	1	0	0	0	0	0	2	0	0	0	0	0	0	0	0	0	0	0	0	0	4	2	0				
% Pedestrians	0.0%	0.0%	0.0%	0.0%	0.0%	100.0%	100.0%	0.0%	0.0%	0.0%	0.0%	0.0%	0.0%	100.0%	0.0%	0.0%	0.0%	0.0%	0.0%	0.0%	0.0%	0.0%	0.0%	0.0%	0.0%	0.0%	0.0%	100.0%	100.0%	0.0%			
Bicycles on Crosswalk	0	0	0	0	0	0	0	0	0	0	0	0	0	0	0	0	0	0	0	0	0	0	0	0	0	0	0	0	0				
% Bicycles on Crosswalk	0.0%	0.0%	0.0%	0.0%	0.0%	0.0%	0.0%	0.0%	0.0%	0.0%	0.0%	0.0%	0.0%	0.0%	0.0%	0.0%	0.0%	0.0%	0.0%	0.0%	0.0%	0.0%	0.0%	0.0%	0.0%	0.0%	0.0%	0.0%	0.0%	0.0%			

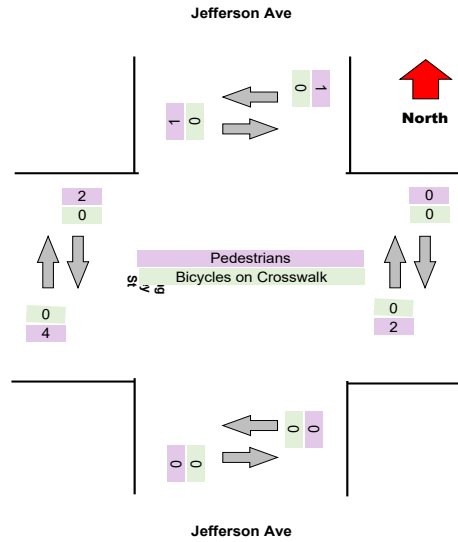
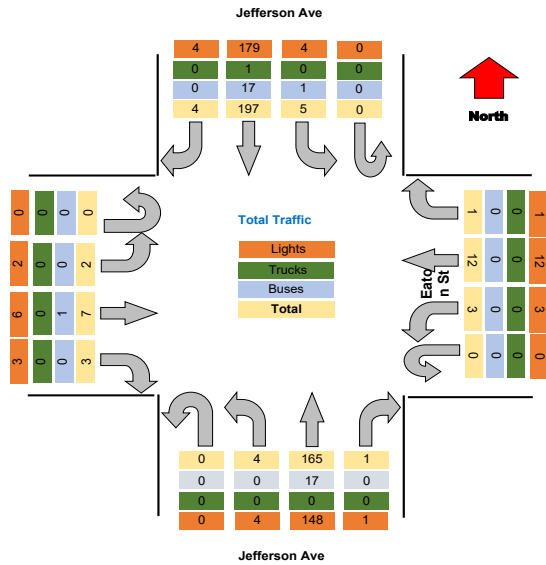

Turning Movement Peak Hour Data (PM)

4:15:00 PM

Leg Direction	Jefferson Ave					Kingsley St					Jefferson Ave					Eaton St					Total									
	Southbound					Westbound					Northbound					Eastbound														
	Right	Thru	Left	U-Turn	App Total	Peds CW	Peds CCW	Right	Thru	Left	U-Turn	App Total	Peds CW	Peds CCW	Right	Thru	Left	U-Turn	App Total	Peds CW		Peds CCW								
4:15:00 PM	2	70	1	0	73	0	0	3	1	0	0	4	0	0	0	81	1	0	82	0	0	12	0	0	171					
4:30:00 PM	2	85	3	0	90	0	0	4	0	3	0	7	1	1	1	64	0	0	65	0	0	2	6	4	0	172				
4:45:00 PM	3	52	4	0	59	0	0	3	1	2	0	6	1	1	1	78	1	0	80	0	0	2	2	0	6	1	0	151		
5:00:00 PM	1	84	1	0	86	0	0	2	5	2	0	9	0	0	0	84	3	0	87	0	0	5	3	3	0	11	2	1	193	
Grand Total	9	288	9	0	305	0	0	12	10	7	0	29	2	2	2	307	5	0	314	0	0	16	11	14	0	41	3	1	689	
% Approach	2.6%	94.4%	3.0%	0.0%	0.0%	0.0%	0.0%	41.4%	34.5%	24.1%	0.0%	0.0%	0.0%	0.0%	0.6%	97.6%	1.6%	0.0%	0.0%	0.0%	0.0%	39.0%	26.8%	34.1%	0.0%	0.0%	0.0%	0.0%	0.0%	
% Total	1.2%	41.8%	1.3%	0.0%	44.3%	0.0%	0.0%	1.7%	1.5%	1.0%	0.0%	4.2%	0.0%	0.0%	0.3%	44.6%	0.7%	0.0%	45.6%	0.0%	0.0%	2.3%	1.6%	2.0%	0.0%	6.0%	0.0%	0.0%	0.0%	
PHF	0.667	0.847	0.563	0.000	0.847	0.000	0.000	0.750	0.313	0.583	0.000	0.604	0.000	0.000	0.500	0.914	0.417	0.000	0.802	0.000	0.000	0.571	0.458	0.700	0.000	0.854	0.000	0.000	0.892	
Lights	7	278	9	0	294	0	0	12	10	7	0	29	0	0	2	300	5	0	307	0	0	16	9	14	0	39	0	0	669	
% Lights	87.5%	96.5%	100.0%	0.0%	96.4%	0.0%	0.0%	100.0%	100.0%	100.0%	0.0%	100.0%	0.0%	0.0%	100.0%	97.7%	100.0%	0.0%	97.8%	0.0%	0.0%	100.0%	81.8%	100.0%	0.0%	95.1%	0.0%	0.0%	97.1%	
Trucks	0	0	0	0	0	0	0	0	0	0	0	0	0	0	0	0	0	0	0	0	0	0	0	0	0	0	0	0	0	
% Trucks	0.0%	0.0%	0.0%	0.0%	0.0%	0.0%	0.0%	0.0%	0.0%	0.0%	0.0%	0.0%	0.0%	0.0%	0.0%	0.0%	0.0%	0.0%	0.0%	0.0%	0.0%	0.0%	0.0%	0.0%	0.0%	0.0%	0.0%	0.0%	0.0%	
Buses	1	10	0	0	11	0	0	0	0	0	0	0	0	0	0	7	0	0	7	0	0	0	2	0	0	2	0	0	20	
% Buses	12.5%	3.5%	0.0%	0.0%	0.0%	0.0%	0.0%	0.0%	0.0%	0.0%	0.0%	0.0%	0.0%	0.0%	0.0%	2.3%	0.0%	0.0%	0.0%	0.0%	0.0%	0.0%	18.2%	0.0%	0.0%	0.0%	0.0%	0.0%	2.9%	
Pedestrians	0	0	0	0	0	0	0	0	0	0	0	2	2	0	0	0	0	0	0	0	1	0	0	0	0	0	3	0	0	
% Pedestrians	0.0%	0.0%	0.0%	0.0%	0.0%	0.0%	0.0%	0.0%	0.0%	0.0%	0.0%	100.0%	100.0%	0.0%	0.0%	0.0%	0.0%	0.0%	0.0%	0.0%	100.0%	0.0%	0.0%	0.0%	0.0%	0.0%	0.0%	100.0%	0.0%	0.0%
Bicycles on Crosswalk	0	0	0	0	0	0	0	0	0	0	0	0	0	0	0	0	0	0	0	0	0	0	0	0	0	0	0	1	0	
% Bicycles on Crosswalk	0.0%	0.0%	0.0%	0.0%	0.0%	0.0%	0.0%	0.0%	0.0%	0.0%	0.0%	0.0%	0.0%	0.0%	0.0%	0.0%	0.0%	0.0%	0.0%	0.0%	0.0%	0.0%	0.0%	0.0%	0.0%	0.0%	0.0%	100.0%	0.0%	

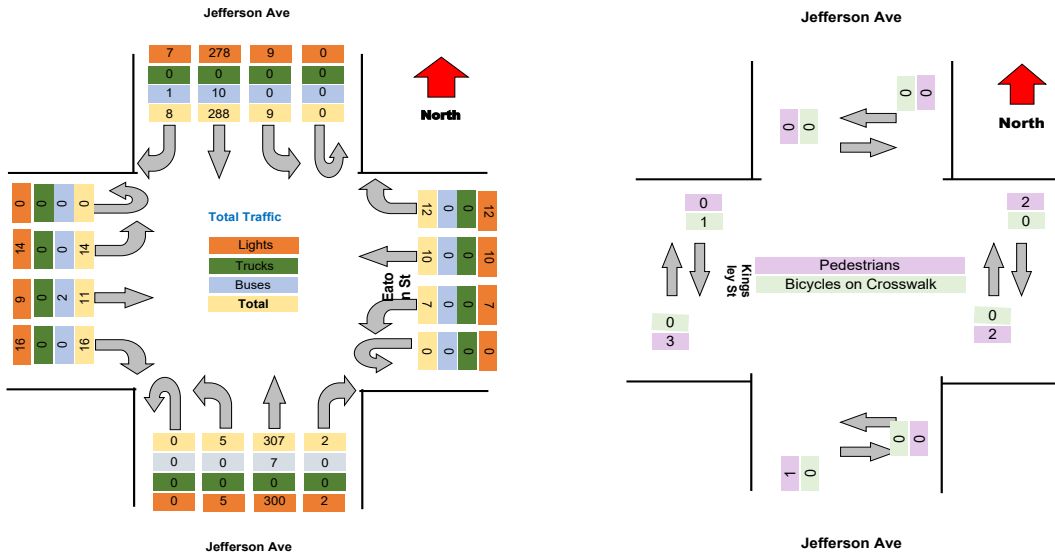

Project : VBH Malta NY
Site : Site 4
Location : 42.948550, -73.790036

TSTData.com

Survey Date : 2021-04-28, Wednesday

Project	LaBella
Project Code	LaBella
Site Name	V
Legs and Movements	All Processed Legs & Move
Bin Size	15 minutes
Survey Date	2021-11-04, Thursday
Location	V
Latitude and Longitude	42.908321, -78.853973

	Start	End	PHF
Forced Peak AM	2021/11/04 07:30:00	2021/11/04 08:30:00	0.95
Forced Peak PM	2021/11/04 16:30:00	2021/11/04 17:30:00	0.92
AM Peak	2021/11/04 07:30:00	2021/11/04 08:30:00	0.95
PM Peak	2021/11/04 16:15:00	2021/11/04 17:15:00	0.94

Turning Movement Data

Leg Direction	Jefferson Ave						Kingsley St						Jefferson Ave						Eaton St						Total				
	Southbound			Northbound			Westbound			Eastbound			Northbound			Eastbound													
Start Time	Right	Thru	Left	U-Turn	App Total	Peds CV	Peds CCV	Right	Thru	Left	U-Turn	App Total	Peds CV	Peds CCV	Right	Thru	Left	U-Turn	App Total	Peds CV	Peds CCV	Right	Thru	Left	U-Turn	App Total	Peds CV	Peds CCV	
6:30:00 AM	0	13	0	0	13	0	0	0	0	1	0	1	0	0	0	17	0	0	17	0	0	1	0	1	0	2	0	0	33
6:45:00 AM	0	10	1	0	11	0	0	0	1	0	0	1	0	1	0	24	1	0	26	0	0	1	1	4	0	6	1	0	44
Hourly Total	0	23	1	0	24	0	0	0	1	1	0	2	0	1	0	41	1	0	43	0	0	2	1	5	0	8	1	0	77
7:00:00 AM	1	17	0	0	18	1	0	1	0	1	0	2	0	0	1	37	0	0	38	0	0	0	0	1	0	1	4	1	59
7:15:00 AM	0	35	2	0	37	0	0	0	3	1	0	4	1	1	0	25	0	0	27	0	0	1	1	1	0	3	2	0	71
7:30:00 AM	0	41	3	0	44	0	0	0	1	0	0	1	1	0	1	34	1	0	37	0	0	1	0	2	0	3	0	0	85
7:45:00 AM	0	47	0	0	47	0	1	0	2	1	0	4	0	0	0	48	2	0	50	0	0	0	2	0	0	2	1	0	103
Hourly Total	1	140	5	0	146	1	1	1	6	3	0	11	2	1	2	144	3	0	152	0	0	2	3	4	0	9	7	1	318
8:00:00 AM	2	46	1	0	49	1	0	0	1	2	0	3	1	0	0	41	1	0	43	0	0	1	2	3	0	6	0	0	101
8:15:00 AM	0	43	1	0	44	0	0	0	2	0	0	2	0	1	0	52	0	0	53	0	0	2	0	1	0	3	2	1	102
Hourly Total	2	89	2	0	93	1	0	0	3	2	0	5	1	1	0	93	1	0	96	0	0	3	2	4	0	9	2	1	203
4:00:00 PM	1	78	2	0	81	0	0	1	1	2	0	4	0	0	0	74	1	0	76	0	0	2	2	3	0	7	1	0	167
4:15:00 PM	4	74	2	0	80	0	0	0	2	1	0	3	0	3	1	80	2	0	83	0	0	5	0	0	0	5	3	1	171
4:30:00 PM	1	62	1	0	64	0	0	1	0	2	0	3	1	1	1	69	3	0	73	0	0	5	1	2	0	8	0	2	148
4:45:00 PM	2	65	0	0	67	1	1	0	2	1	0	3	1	1	1	84	4	0	89	0	0	1	2	5	0	8	1	2	167
Hourly Total	8	279	5	0	292	1	1	2	5	6	0	13	2	5	3	307	10	0	320	0	0	13	5	10	0	28	5	5	653
5:00:00 PM	0	75	0	0	75	0	0	3	1	2	0	6	0	0	3	71	1	0	75	0	0	1	0	1	0	2	1	0	158
5:15:00 PM	2	64	2	0	68	1	0	1	0	0	0	1	0	0	1	59	4	0	64	0	0	4	2	3	0	9	2	0	142
5:30:00 PM	0	67	2	0	69	0	0	2	0	0	0	2	0	0	0	59	4	0	63	0	0	3	1	1	0	5	1	4	139
5:45:00 PM	0	59	2	0	61	0	0	1	2	1	0	4	1	0	0	59	1	0	60	0	0	4	1	2	0	7	1	0	132
Hourly Total	2	265	6	0	273	1	0	7	3	3	0	13	1	0	4	248	10	0	262	0	0	12	4	7	0	23	5	4	671
Grand Total	13	796	19	0	828	4	2	10	18	15	0	44	6	8	9	833	25	0	873	0	0	32	15	30	0	77	20	11	1822
% Approach	1.6%	96.1%	2.3%	0.0%	0.0%	0.0%	0.0%	22.7%	40.9%	34.1%	0.0%	0.0%	0.0%	0.0%	1.0%	95.4%	2.9%	0.0%	0.0%	0.0%	0.0%	41.6%	19.5%	39.0%	0.0%	0.0%	0.0%	0.0%	0.0%
% Total	0.7%	43.7%	1.0%	0.0%	45.4%	0.0%	0.0%	0.5%	1.0%	0.8%	0.0%	2.4%	0.0%	0.0%	0.5%	45.7%	1.4%	0.0%	47.9%	0.0%	0.0%	1.8%	0.8%	1.6%	0.0%	4.2%	0.0%	0.0%	0.0%
Lights	11	759	17	0	787	0	0	10	18	13	0	41	0	0	8	791	25	0	824	0	0	31	14	29	0	74	0	0	1728
% Lights	84.6%	95.4%	89.5%	0.0%	95.0%	0.0%	0.0%	100.0%	100.0%	86.7%	0.0%	93.2%	0.0%	0.0%	88.9%	95.0%	100.0%	0.0%	94.4%	0.0%	0.0%	96.9%	93.3%	96.7%	0.0%	96.1%	0.0%	0.0%	94.7%
Trucks	0	0	0	0	0	0	0	0	0	0	0	0	0	0	0	2	0	0	2	0	0	0	0	0	0	0	0	0	2
% Trucks	0.0%	0.0%	0.0%	0.0%	0.0%	0.0%	0.0%	0.0%	0.0%	0.0%	0.0%	0.0%	0.0%	0.0%	0.0%	0.2%	0.0%	0.0%	0.2%	0.0%	0.0%	0.0%	0.0%	0.0%	0.0%	0.0%	0.0%	0.0%	0.1%
Buses	2	37	2	0	41	0	0	0	0	2	0	2	0	0	1	39	0	0	40	0	0	1	1	1	0	3	0	0	86
% Buses	15.4%	4.6%	10.5%	0.0%	0.0%	0.0%	0.0%	0.0%	0.0%	13.3%	0.0%	0.0%	0.0%	0.0%	11.1%	4.7%	0.0%	0.0%	0.0%	0.0%	0.0%	3.1%	6.7%	3.3%	0.0%	0.0%	0.0%	0.0%	4.7%
Pedestrians	0	0	0	0	0	4	2	0	0	0	0	0	5	7	0	0	0	0	0	0	0	0	0	0	0	0	20	10	0
% Pedestrians	0.0%	0.0%	0.0%	0.0%	0.0%	100.0%	100.0%	0.0%	0.0%	0.0%	0.0%	0.0%	83.3%	87.9%	0.0%	0.0%	0.0%	0.0%	0.0%	0.0%	0.0%	0.0%	0.0%	0.0%	0.0%	0.0%	100.0%	89.9%	0.0%
Bicycles on Crosswalk	0	0	0	0	0	0	0	0	0	0	0	0	1	1	0	0	0	0	0	0	0	0	0	0	0	0	0	1	0
% Bicycles on Crosswalk	0.0%	0.0%	0.0%	0.0%	0.0%	0.0%	0.0%	0.0%	0.0%	0.0%	0.0%	0.0%	16.7%	12.9%	0.0%	0.0%	0.0%	0.0%	0.0%	0.0%	0.0%	0.0%	0.0%	0.0%	0.0%	0.0%	0.0%	9.1%	0.0%

Project : VBH Malta NY
 Site : Site 4
 Location : 42.948550, -73.790036
 Survey Date : 2021-04-28, Wednesday

Turning Movement Data Plot

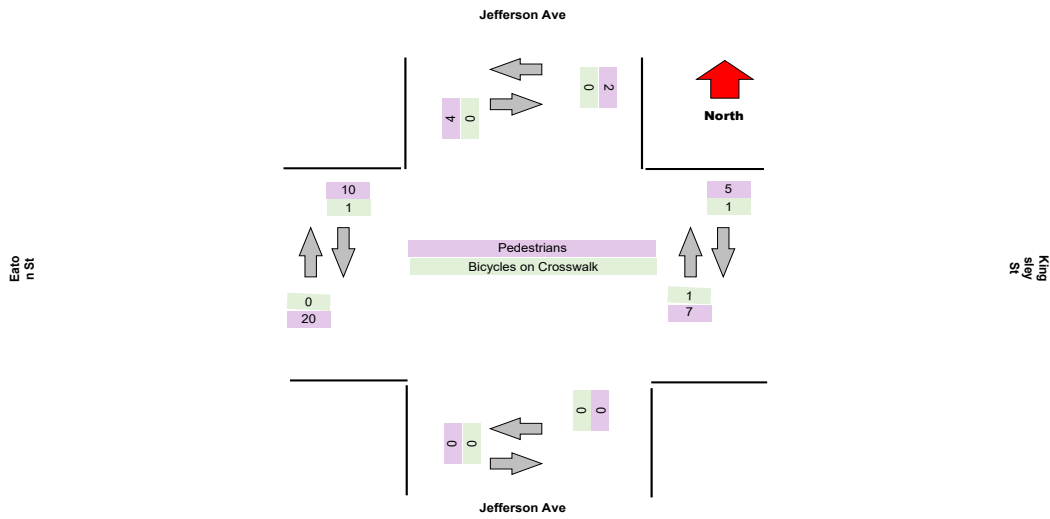
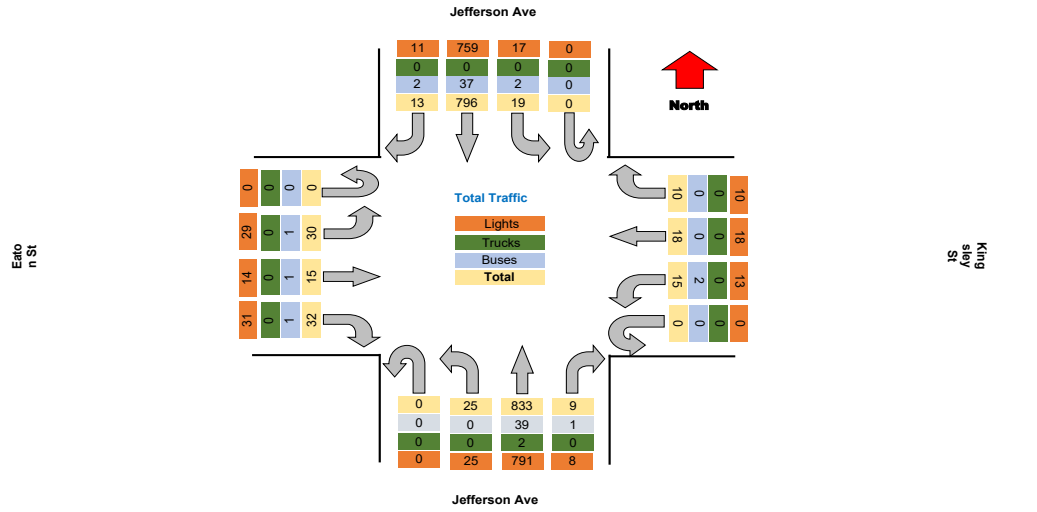

Project : VBH Malta NY
Site : Site 4
Location : 42.948550, -73.790036
Survey Date : 2021-04-28, Wednesday

TSTData.com

Turning Movement Peak Hour Data (AM)

7:30:00 AM

Leg Direction	Jefferson Ave					Kingsley St					Jefferson Ave					Eaton St					Total									
	Right	Thru	Left	U-Turn	App Total	Peds CW	Peds CCW	Right	Thru	Left	U-Turn	App Total	Peds CW	Peds CCW	Right	Thru	Left	U-Turn	App Total	Peds CW		Peds CCW								
7:30:00 AM	0	41	3	0	44	0	0	0	0	1	0	0	1	1	0	0	0	0	37	0	0	1	0	2	0	3	0	0	85	
7:45:00 AM	0	47	0	0	47	0	2	1	0	4	0	0	0	0	0	48	2	0	0	50	0	0	0	2	0	0	2	1	0	103
8:00:00 AM	2	46	1	0	49	0	1	2	0	3	1	0	0	0	41	1	0	0	43	0	0	1	2	3	0	6	0	0	101	
8:15:00 AM	0	43	1	0	44	0	2	0	0	2	0	1	0	0	52	0	0	0	53	0	0	2	0	1	0	3	2	1	102	
Grand Total	2	177	5	0	184	0	5	3	0	10	2	1	1	1	175	4	0	0	183	0	0	4	4	6	0	14	3	1	391	
% Approach	1.1%	96.2%	2.7%	0.0%	0.0%	0.0%	60.0%	30.0%	0.0%	0.0%	0.0%	0.0%	0.0%	0.0%	0.5%	95.6%	2.2%	0.0%	0.0%	28.6%	26.6%	42.9%	0.0%	0.0%	0.0%	0.0%	0.0%	0.0%	0.0%	
% Total	0.5%	45.3%	1.3%	0.0%	47.1%	0.0%	1.5%	0.8%	0.0%	2.6%	0.0%	0.0%	0.0%	0.3%	44.8%	1.0%	0.0%	0.0%	46.8%	0.0%	0.0%	1.0%	1.0%	1.5%	0.0%	3.6%	0.0%	0.0%		
PHF	0.250	0.941	0.417	0.000	0.939	0.000	0.750	0.375	0.000	0.625	0.000	0.000	0.000	0.250	0.841	0.500	0.000	0.863	0.000	0.000	0.500	0.000	0.583	0.000	0.000	0.000	0.000	0.949		
Lights	2	165	4	0	171	0	6	3	0	9	0	0	0	1	158	4	0	0	163	0	0	4	3	5	0	12	0	0	355	
% Lights	100.0%	93.2%	80.0%	0.0%	92.9%	0.0%	100.0%	100.0%	0.0%	90.0%	0.0%	0.0%	0.0%	100.0%	90.3%	100.0%	0.0%	89.1%	0.0%	0.0%	0.0%	100.0%	75.0%	83.3%	0.0%	85.7%	0.0%	0.0%	90.8%	
Trucks	0	0	0	0	0	0	0	0	0	0	0	0	0	0	1	0	0	0	1	0	0	0	0	0	0	0	0	0	1	
% Trucks	0.0%	0.0%	0.0%	0.0%	0.0%	0.0%	0.0%	0.0%	0.0%	0.0%	0.0%	0.0%	0.0%	0.0%	0.0%	0.0%	0.0%	0.0%	0.5%	0.0%	0.0%	0.0%	0.0%	0.0%	0.0%	0.0%	0.0%	0.0%	0.3%	
Buses	0	12	1	0	13	0	0	0	0	0	0	0	0	0	16	0	0	0	16	0	0	0	1	1	0	2	0	0	31	
% Buses	0.0%	6.8%	20.0%	0.0%	0.0%	0.0%	0.0%	0.0%	0.0%	0.0%	0.0%	0.0%	0.0%	0.0%	9.1%	0.0%	0.0%	0.0%	0.0%	0.0%	0.0%	0.0%	25.0%	16.7%	0.0%	0.0%	0.0%	0.0%	7.9%	
Pedestrians	0	0	0	0	0	1	1	0	0	2	1	0	0	0	0	0	0	0	0	0	0	0	0	0	0	0	3	1	0	
% Pedestrians	0.0%	0.0%	0.0%	0.0%	0.0%	100.0%	100.0%	0.0%	0.0%	0.0%	100.0%	100.0%	0.0%	0.0%	0.0%	0.0%	0.0%	0.0%	0.0%	0.0%	0.0%	0.0%	0.0%	0.0%	0.0%	0.0%	100.0%	100.0%	0.0%	
Bicycles on Crosswalk	0	0	0	0	0	0	0	0	0	0	0	0	0	0	0	0	0	0	0	0	0	0	0	0	0	0	0	0	0	
% Bicycles on Crosswalk	0.0%	0.0%	0.0%	0.0%	0.0%	0.0%	0.0%	0.0%	0.0%	0.0%	0.0%	0.0%	0.0%	0.0%	0.0%	0.0%	0.0%	0.0%	0.0%	0.0%	0.0%	0.0%	0.0%	0.0%	0.0%	0.0%	0.0%	0.0%	0.0%	

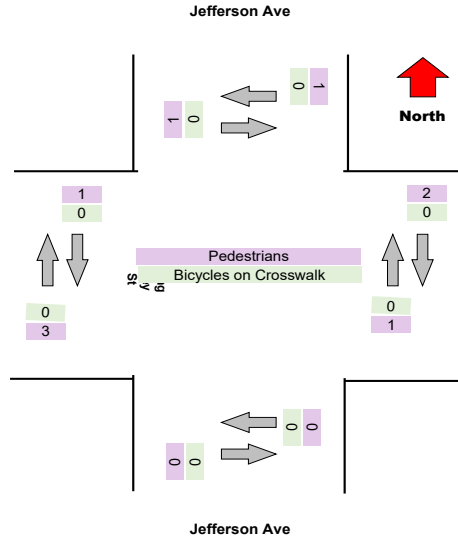
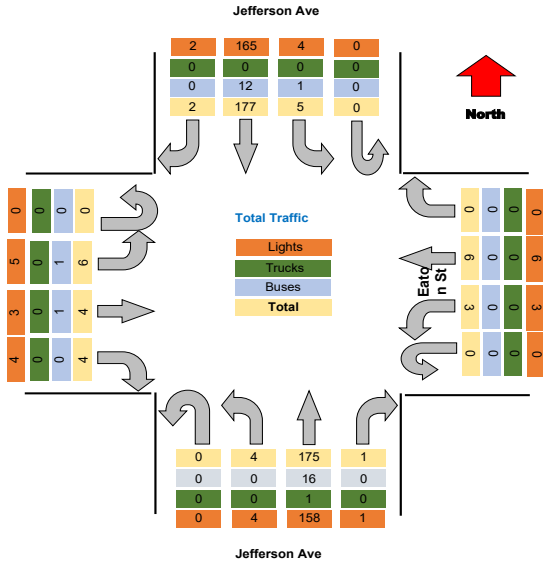

Project : VBH Malta NY
Site : Site 4
Location : 42.948550, -73.790036

TSTData.com

Survey Date : 2021-04-28, Wednesday

Turning Movement Peak Hour Data (PM)

4:15:00 PM

Leg Direction	Jefferson Ave					Kingsley St					Jefferson Ave					Eaton St					Total									
	Southbound					Westbound					Northbound					Eastbound														
	Right	Thru	Left	U-Turn	App Total	Peds CW	Peds CCW	Right	Thru	Left	U-Turn	App Total	Peds CW	Peds CCW	Right	Thru	Left	U-Turn	App Total	Peds CW		Peds CCW								
4:15:00 PM	4	74	2	0	80	0	0	0	2	1	0	3	0	3	1	80	2	0	83	0	0	5	0	0	5	3	1	171		
4:30:00 PM	1	62	1	0	64	0	0	1	0	2	0	3	1	1	1	69	3	0	73	0	0	5	1	2	8	0	2	148		
4:45:00 PM	2	65	0	0	67	1	1	0	2	1	0	3	1	1	1	84	4	0	89	0	0	1	2	5	0	8	1	2	167	
5:00:00 PM	0	75	0	0	75	0	0	3	1	2	0	6	0	0	3	71	1	0	75	0	0	1	0	1	0	2	1	0	158	
Grand Total	7	276	3	0	286	1	1	4	5	6	0	15	2	5	6	304	10	0	320	0	0	12	3	8	0	23	3	644		
% Approach	2.4%	96.5%	1.0%	0.0%	0.0%	0.0%	0.0%	28.7%	33.3%	40.0%	0.0%	0.0%	0.0%	0.0%	1.9%	95.0%	3.1%	0.0%	0.0%	0.0%	0.0%	52.2%	13.0%	34.8%	0.0%	0.0%	0.0%	0.0%		
% Total	1.1%	42.9%	0.5%	0.0%	44.4%	0.0%	0.0%	0.6%	0.8%	0.9%	0.0%	2.3%	0.0%	0.0%	0.9%	47.2%	1.6%	0.0%	49.7%	0.0%	0.0%	1.9%	0.5%	1.2%	0.0%	3.6%	0.0%	0.0%		
PHF	0.438	0.920	0.375	0.000	0.894	0.000	0.000	0.333	0.625	0.750	0.000	0.625	0.000	0.000	0.500	0.905	0.625	0.000	0.899	0.000	0.000	0.600	0.375	0.400	0.000	0.719	0.000	0.000	0.942	
Lights	6	266	3	0	275	0	0	4	5	6	0	15	0	0	5	294	10	0	309	0	0	11	3	8	0	22	0	0	621	
% Lights	85.7%	96.4%	100.0%	0.0%	96.2%	0.0%	0.0%	100.0%	100.0%	100.0%	0.0%	100.0%	0.0%	0.0%	83.3%	96.7%	100.0%	0.0%	96.6%	0.0%	0.0%	91.7%	100.0%	100.0%	0.0%	95.7%	0.0%	0.0%	96.4%	
Trucks	0	0	0	0	0	0	0	0	0	0	0	0	0	0	0	0	0	0	0	0	0	0	0	0	0	0	0	0	0	
% Trucks	0.0%	0.0%	0.0%	0.0%	0.0%	0.0%	0.0%	0.0%	0.0%	0.0%	0.0%	0.0%	0.0%	0.0%	0.0%	0.0%	0.0%	0.0%	0.0%	0.0%	0.0%	0.0%	0.0%	0.0%	0.0%	0.0%	0.0%	0.0%	0.0%	
Buses	1	10	0	0	11	0	0	0	0	0	0	0	0	0	1	9	0	0	10	0	0	1	0	0	0	1	0	0	22	
% Buses	14.3%	3.6%	0.0%	0.0%	0.0%	0.0%	0.0%	0.0%	0.0%	0.0%	0.0%	0.0%	0.0%	0.0%	16.7%	3.0%	0.0%	0.0%	0.0%	0.0%	0.0%	8.3%	0.0%	0.0%	0.0%	0.0%	0.0%	0.0%	3.4%	
Pedestrians	0	0	0	0	0	1	1	0	0	0	0	2	4	0	0	0	0	0	0	0	0	0	0	0	0	0	5	4	0	
% Pedestrians	0.0%	0.0%	0.0%	0.0%	0.0%	100.0%	100.0%	0.0%	0.0%	0.0%	0.0%	0.0%	100.0%	80.0%	0.0%	0.0%	0.0%	0.0%	0.0%	0.0%	0.0%	0.0%	0.0%	0.0%	0.0%	0.0%	0.0%	100.0%	80.0%	0.0%
Bicycles on Crosswalk	0	0	0	0	0	0	0	0	0	0	0	1	0	0	0	0	0	0	0	0	0	0	0	0	0	0	0	1	0	
% Bicycles on Crosswalk	0.0%	0.0%	0.0%	0.0%	0.0%	0.0%	0.0%	0.0%	0.0%	0.0%	0.0%	0.0%	0.0%	20.0%	0.0%	0.0%	0.0%	0.0%	0.0%	0.0%	0.0%	0.0%	0.0%	0.0%	0.0%	0.0%	0.0%	20.0%	0.0%	

